

This catalog covers:
'07 ZX600 P7F

GRID NO. **A-1** This grid covers:
Title



PARTS CATALOG

'07 ZX600 P7F

(NINJA ZX-6R)

Publications	A-2
Model Identification	A-4
Engine	B-1
Chassis	E-1

© Kawasaki Heavy Industries, Ltd. 2007

Engine No. Location:
Upper crankcase, rear side

Year & Model	'07 ZX600P7F
Color	1. Ebony (H8) 2. Lime Green (777) 3. Pearl Wildfire Orange (17H)
VIN No. Range	JKAZX600PPA000001 ~
Engine No. Range	ZX600PE000001 ~

Revised: Jan. 2007

'07 ZX600 P7F(EU) 99912-1474-02

This catalog covers:
'07 ZX600 P7F

GRID NO.

A-2

This grid covers:
Publications

Year & Model	Owner's Manual	A&P Manual		Service Manual		Microfiche
		General	Supplement	Basic	Supplement	
2007 ZX600P7F	99976-1308 99986-1359	99931-1475-01		99924-1382-01		99912-1474-02

ZX600P7F

Left Side View

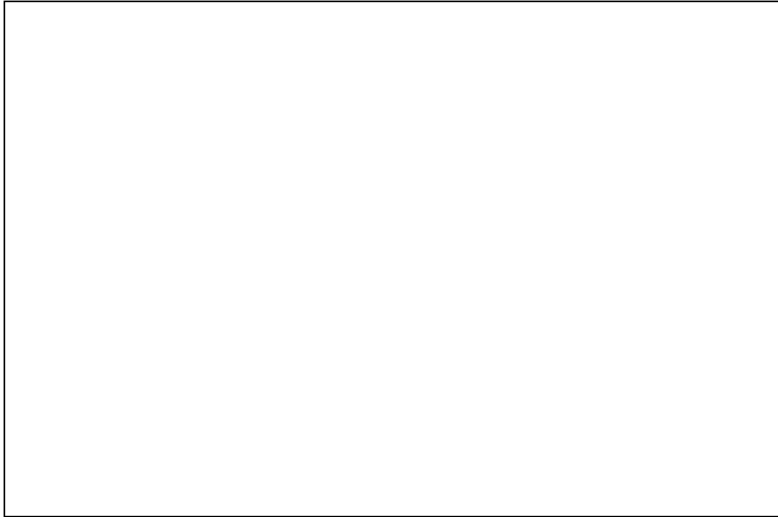

Right Side View

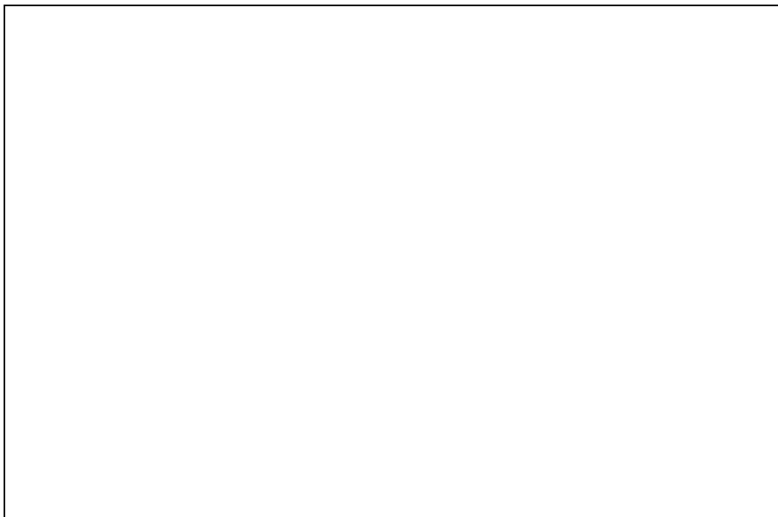

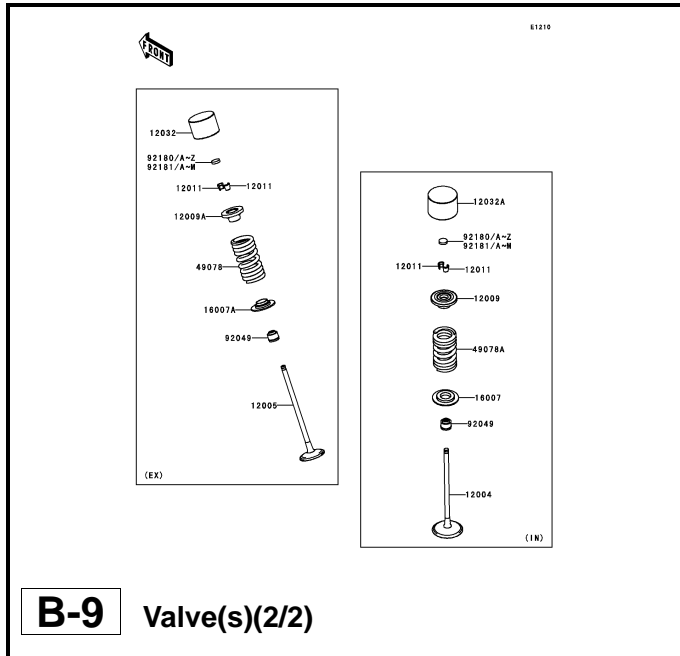

B-9 Valve(s)(2/2)

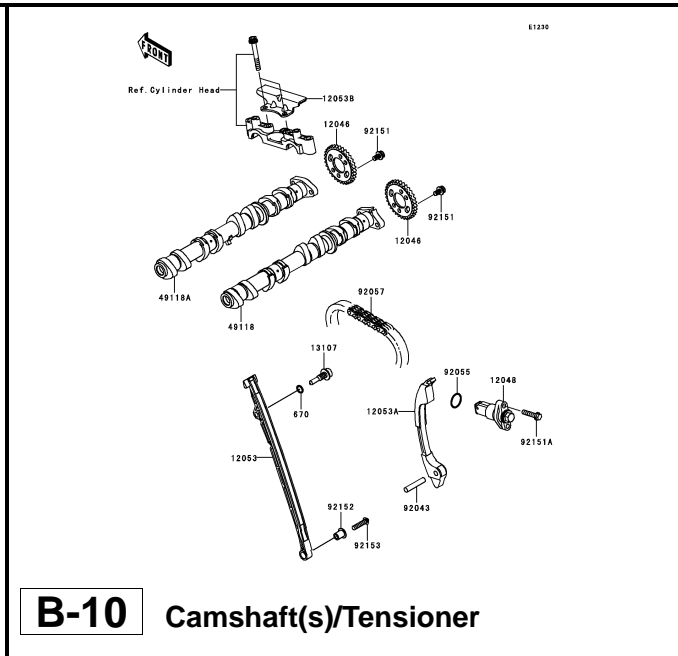

B-10 Camshaft(s)/Tensioner

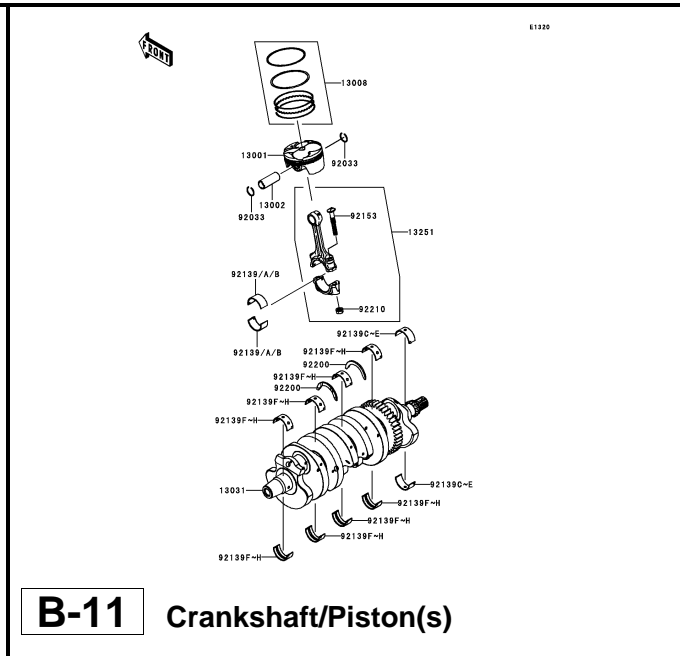

B-11 Crankshaft/Piston(s)

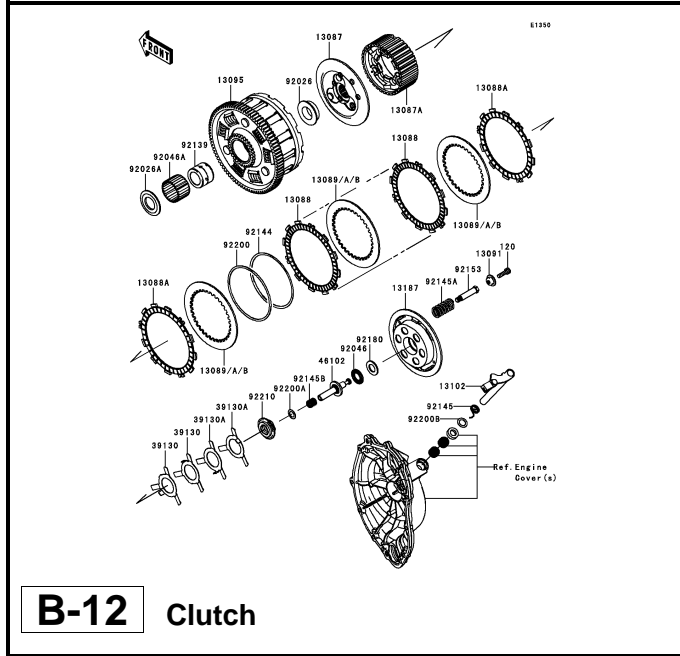

B-12 Clutch

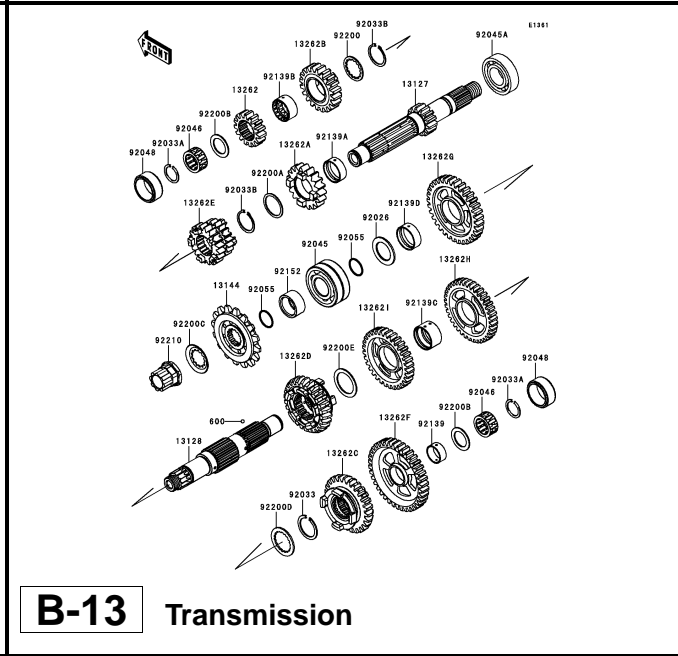

B-13 Transmission

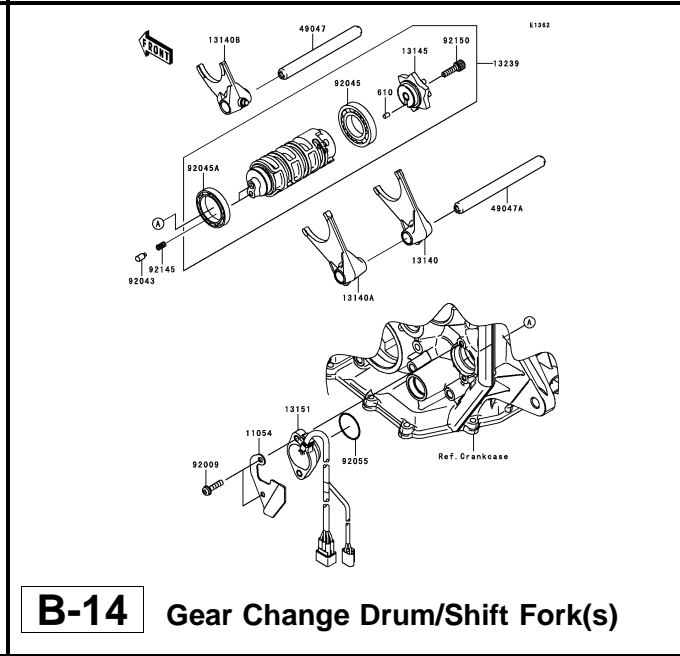

B-14 Gear Change Drum/Shift Fork(s)

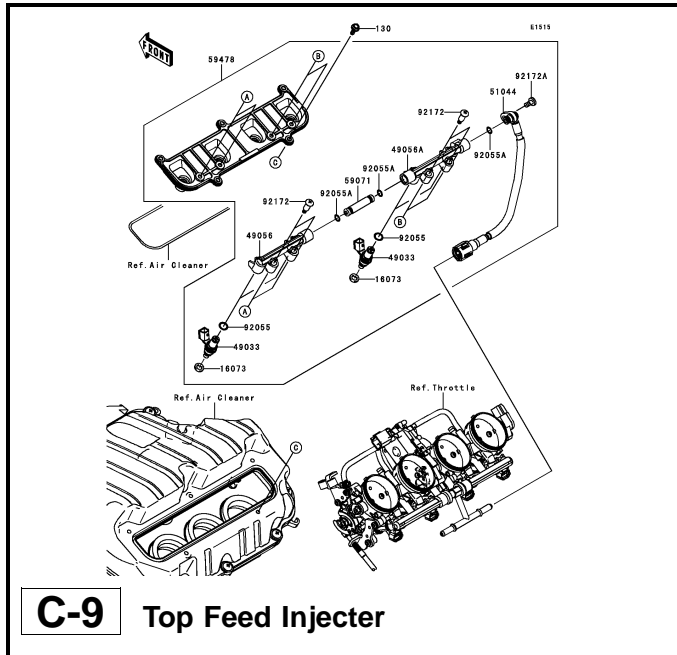

C-9 Top Feed Injector

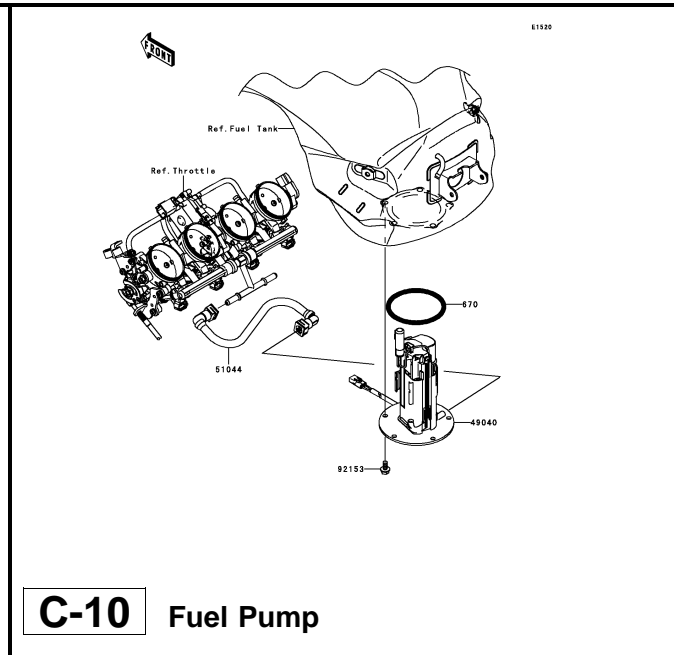

C-10 Fuel Pump

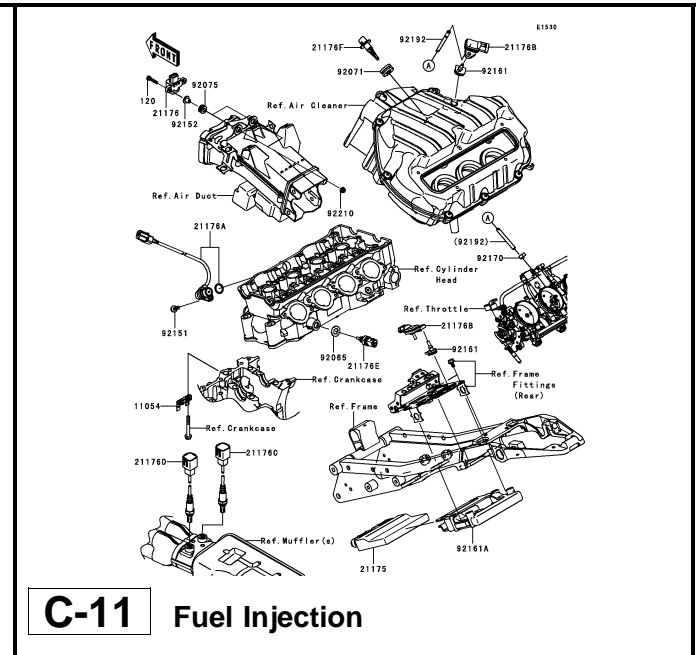

C-11 Fuel Injection

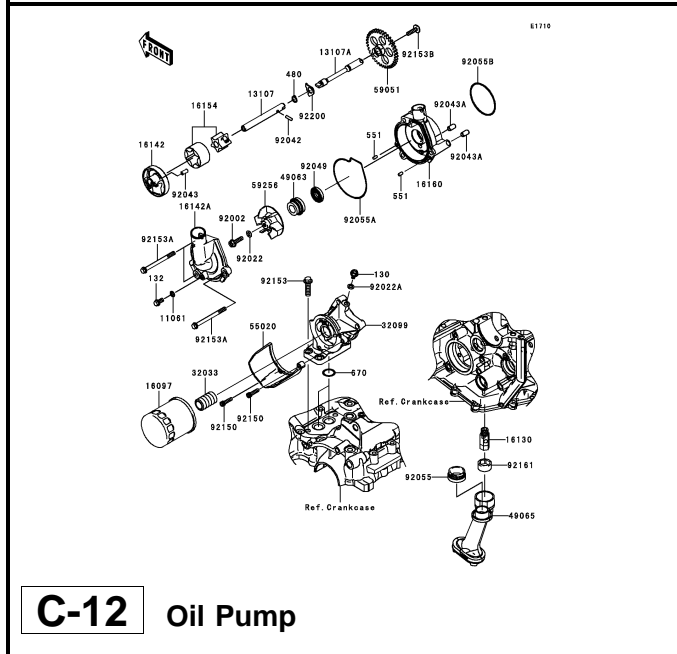

C-12 Oil Pump

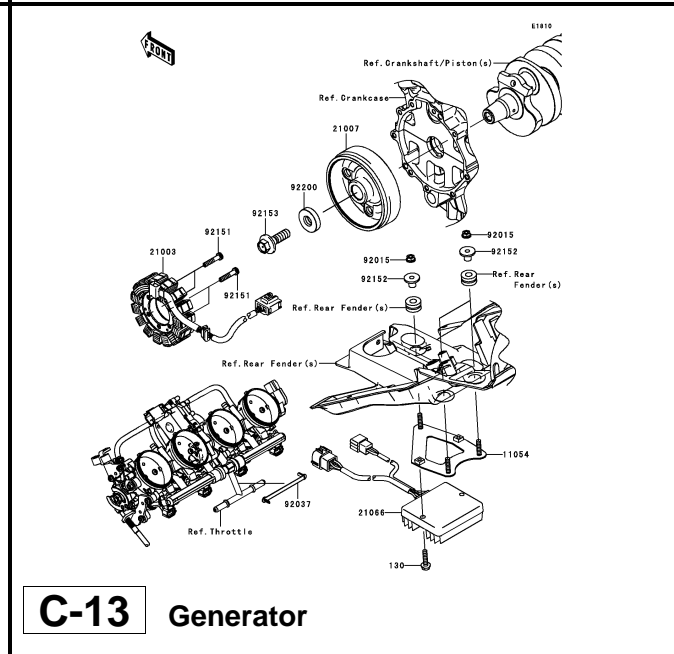

C-13 Generator

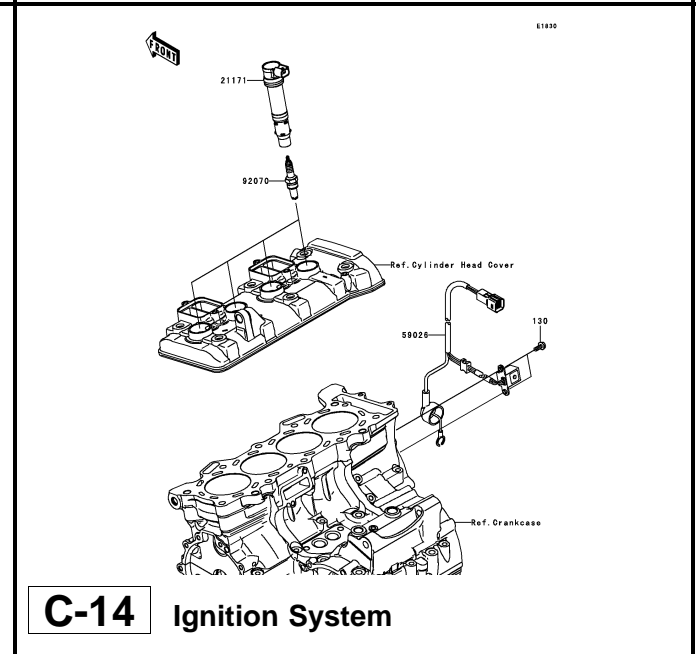

C-14 Ignition System

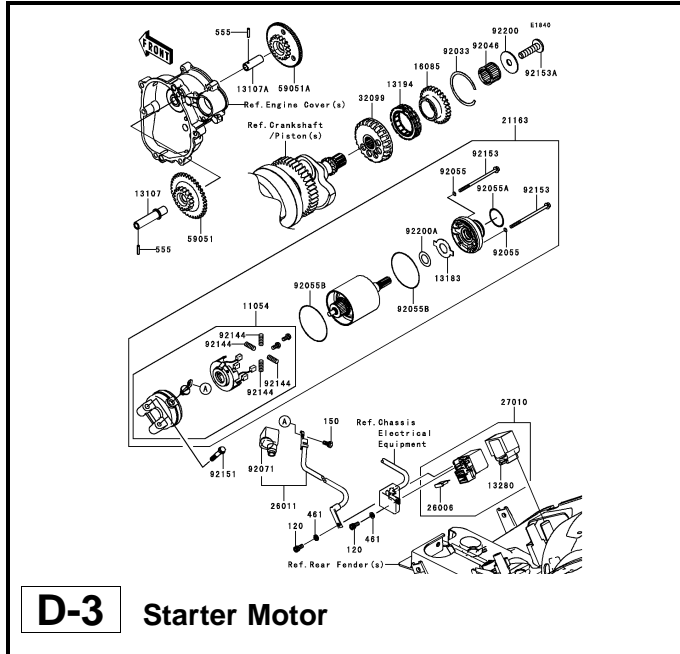

D-3 Starter Motor

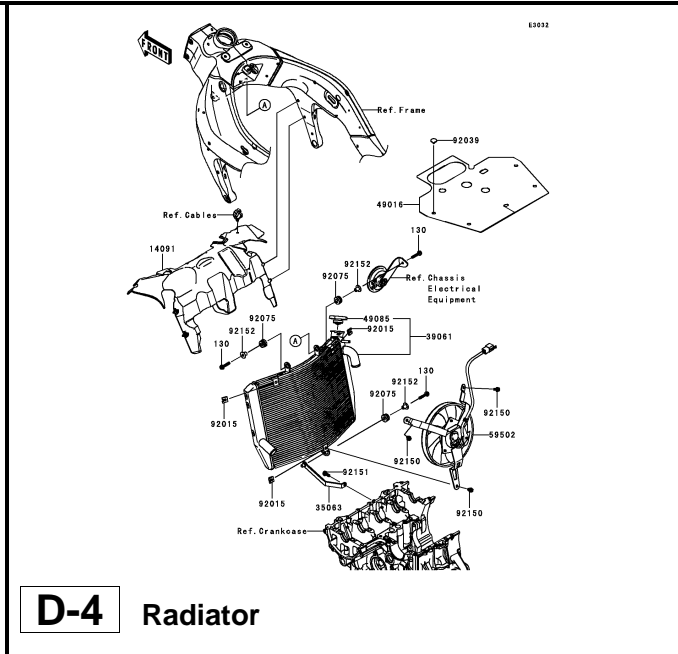

D-4 Radiator

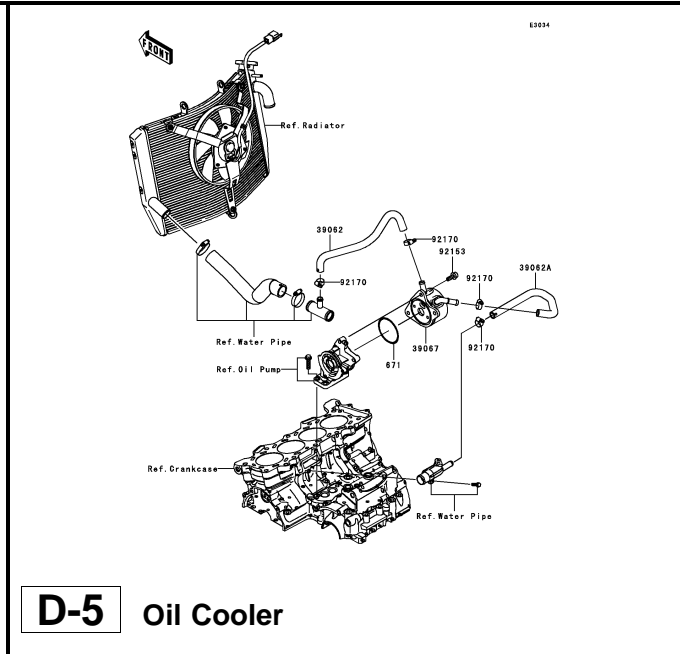

D-5 Oil Cooler

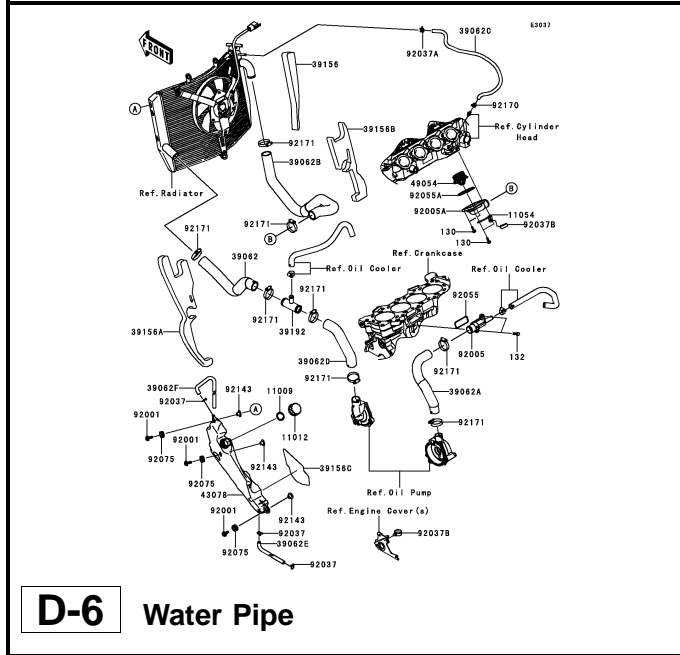

D-6 Water Pipe

This catalog covers:

'07 ZX600P7F Engine

GRID NO.

D-2

This grid covers:

Pictorial Index

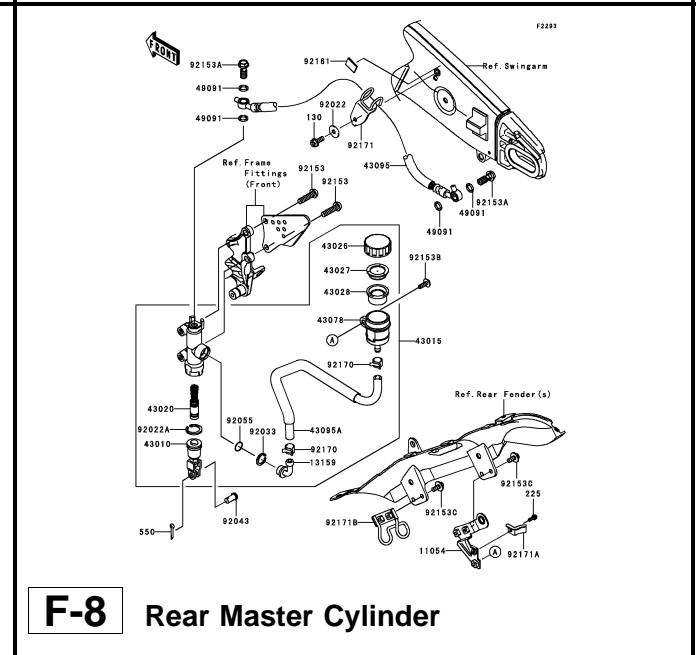
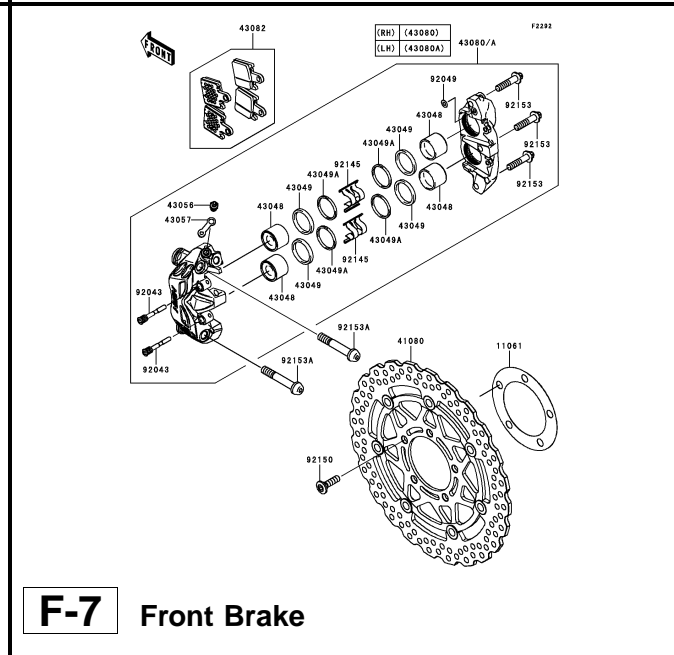
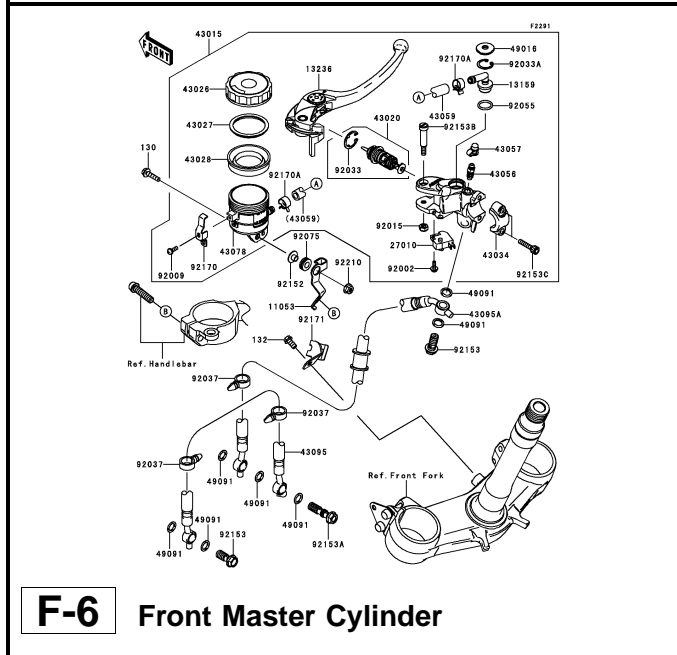
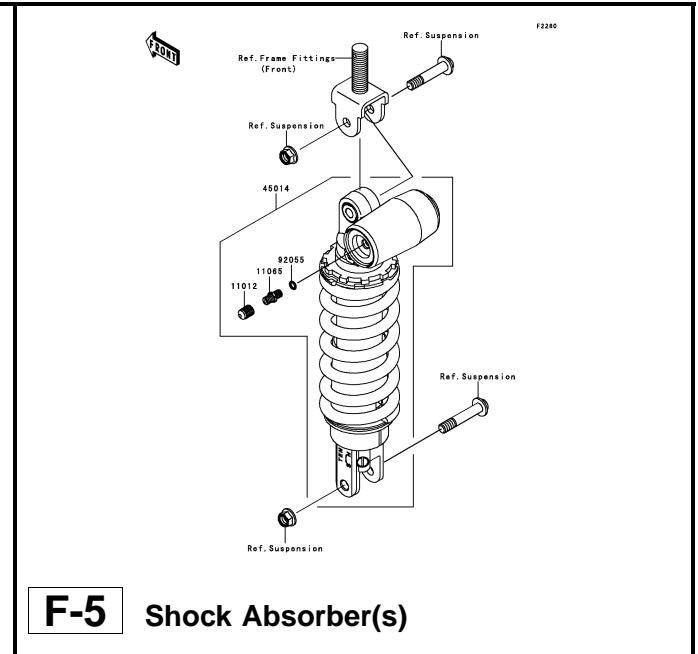
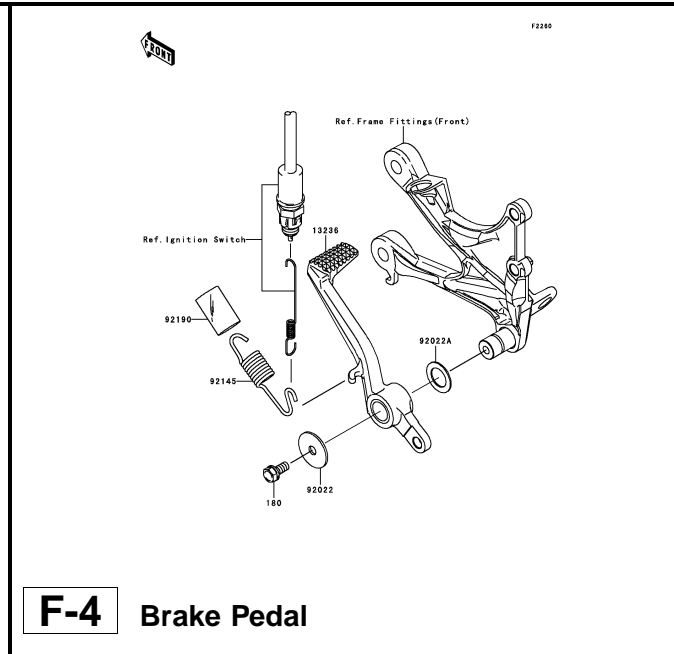
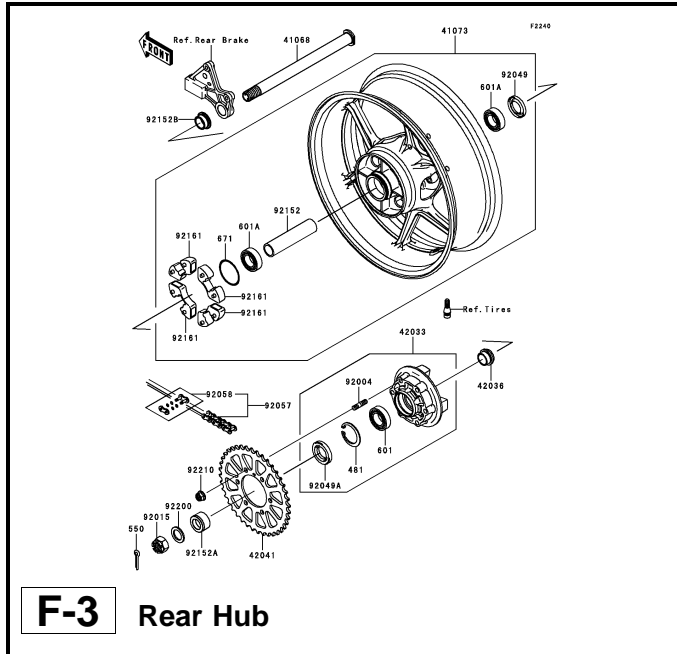

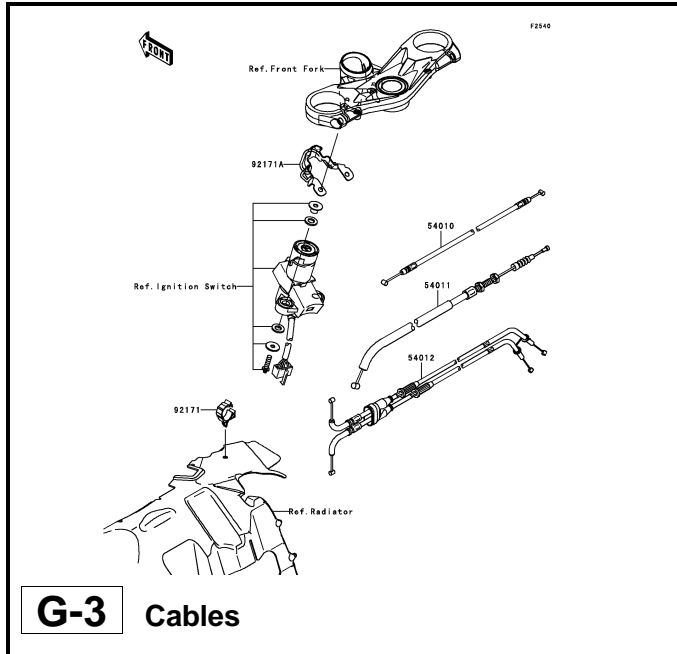

G-3 Cables

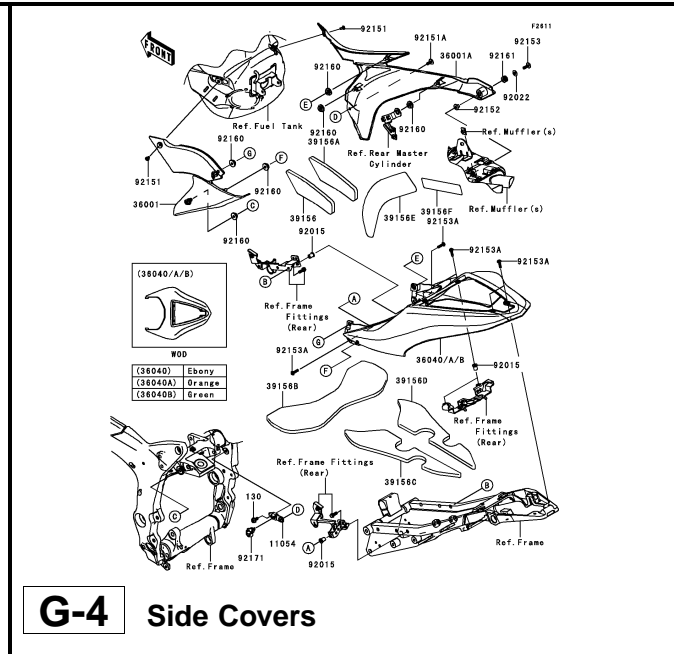

G-4 Side Covers

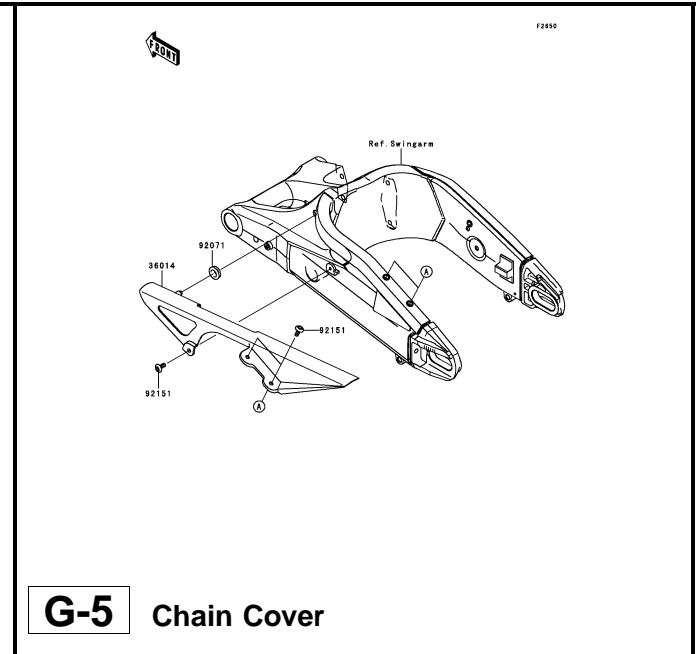

G-5 Chain Cover

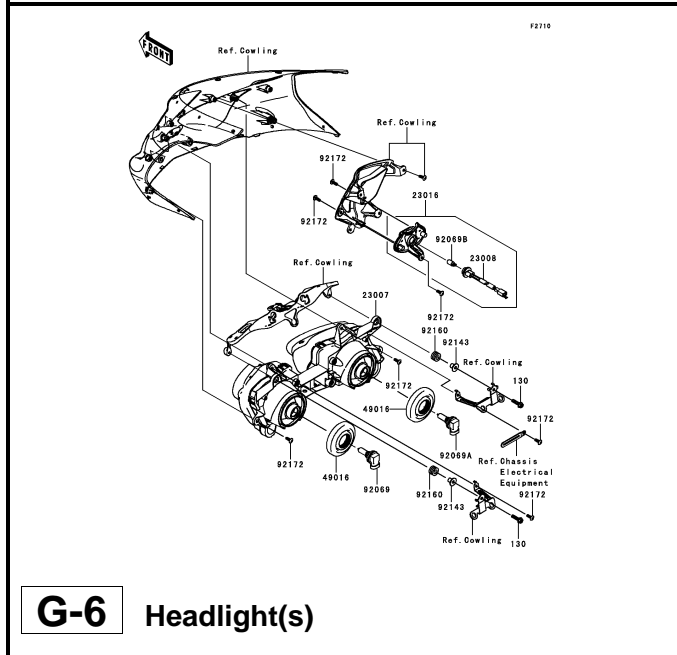

G-6 Headlight(s)

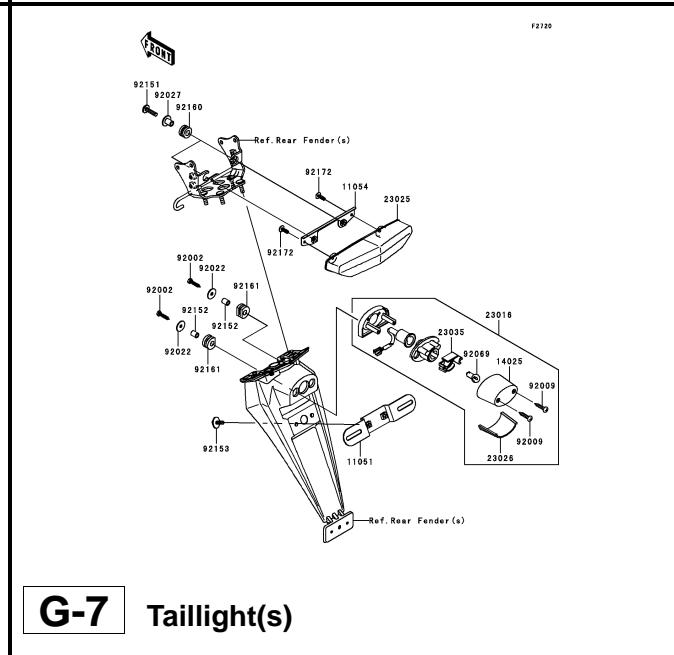

G-7 Taillight(s)

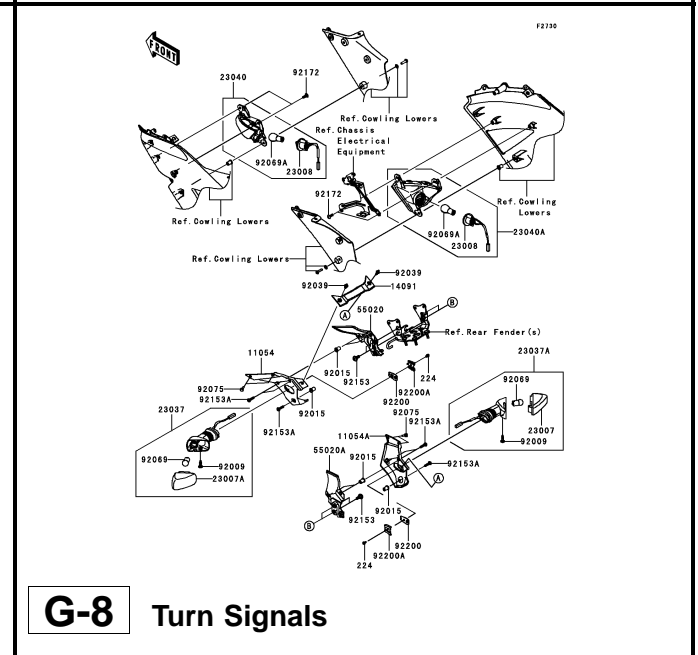

G-8 Turn Signals

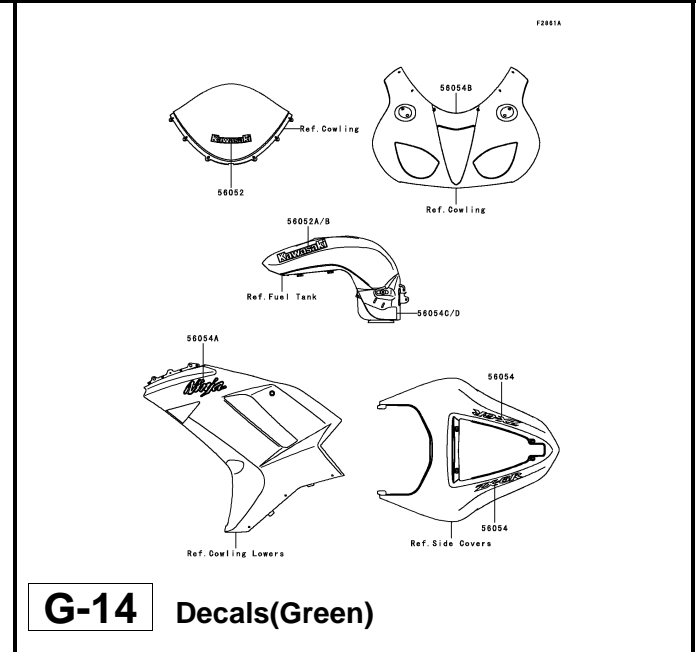
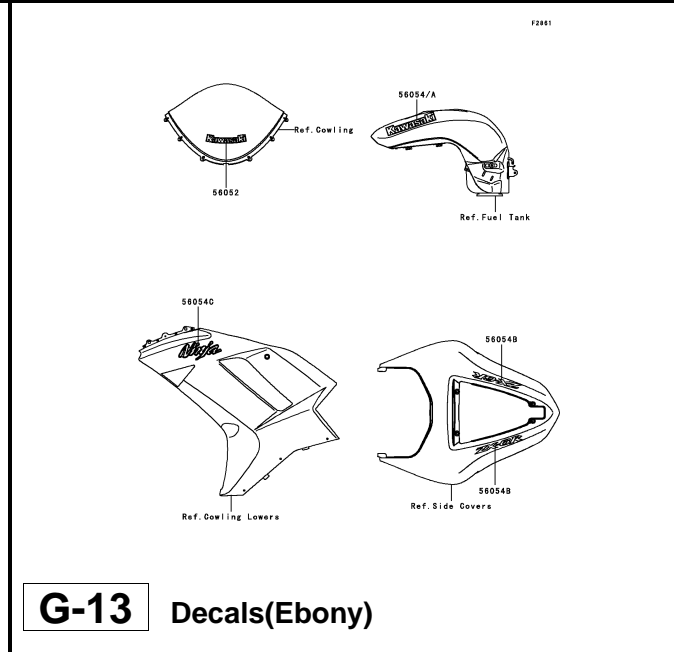
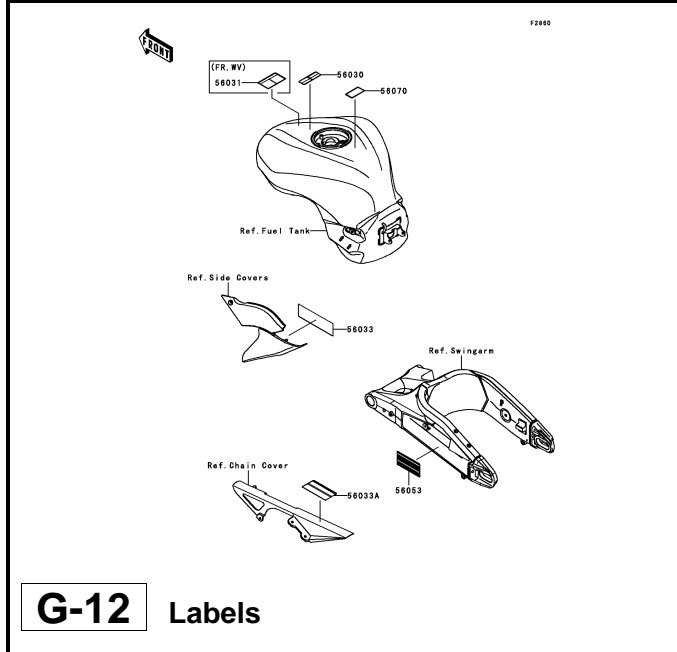
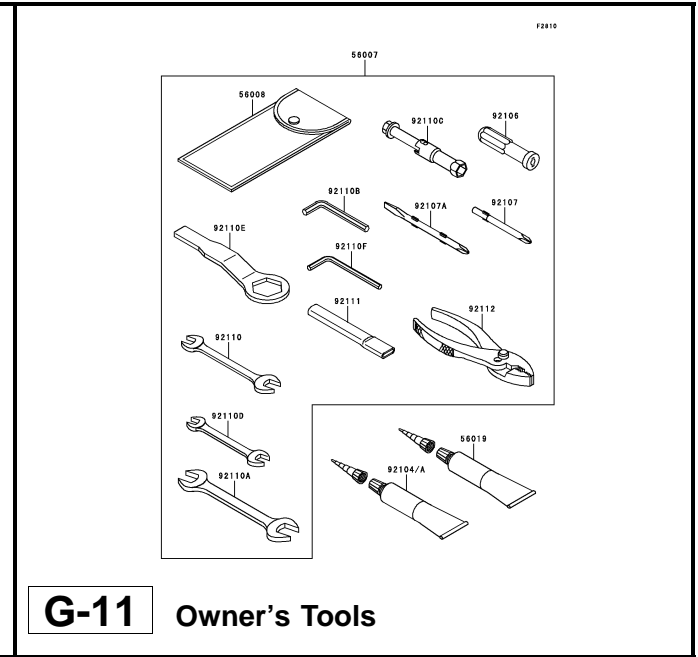
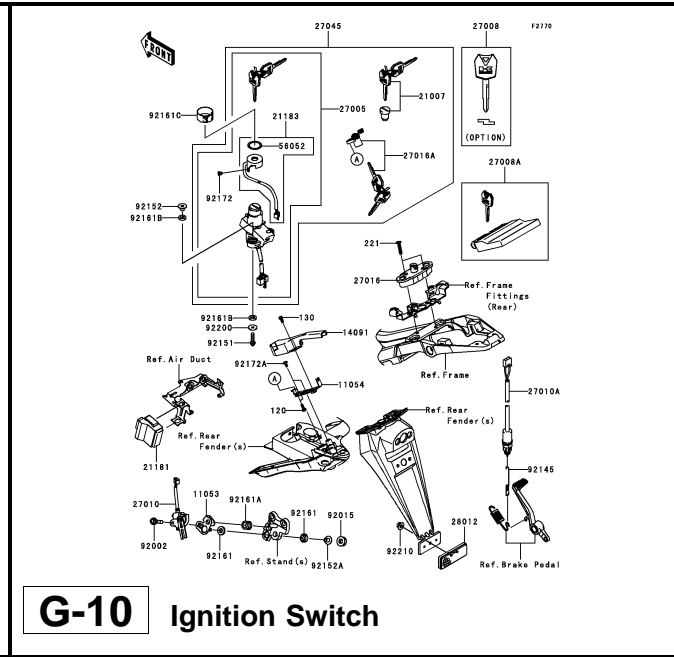
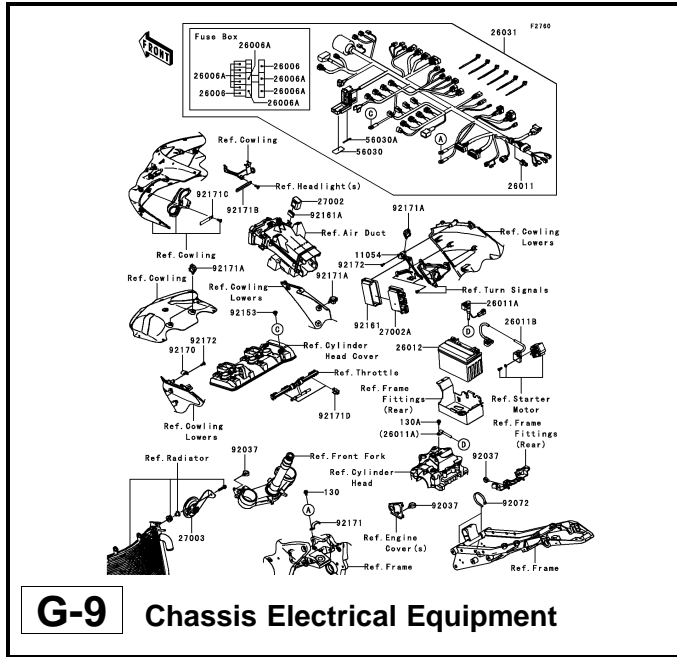

This catalog covers:

'07 ZX600P7F Chassis

GRID NO.

H-2

This grid covers:

Pictorial Index

This catalog covers:
'07 ZX600P7F Engine

GRID NO. **B-3** This grid covers:
Cylinder Head

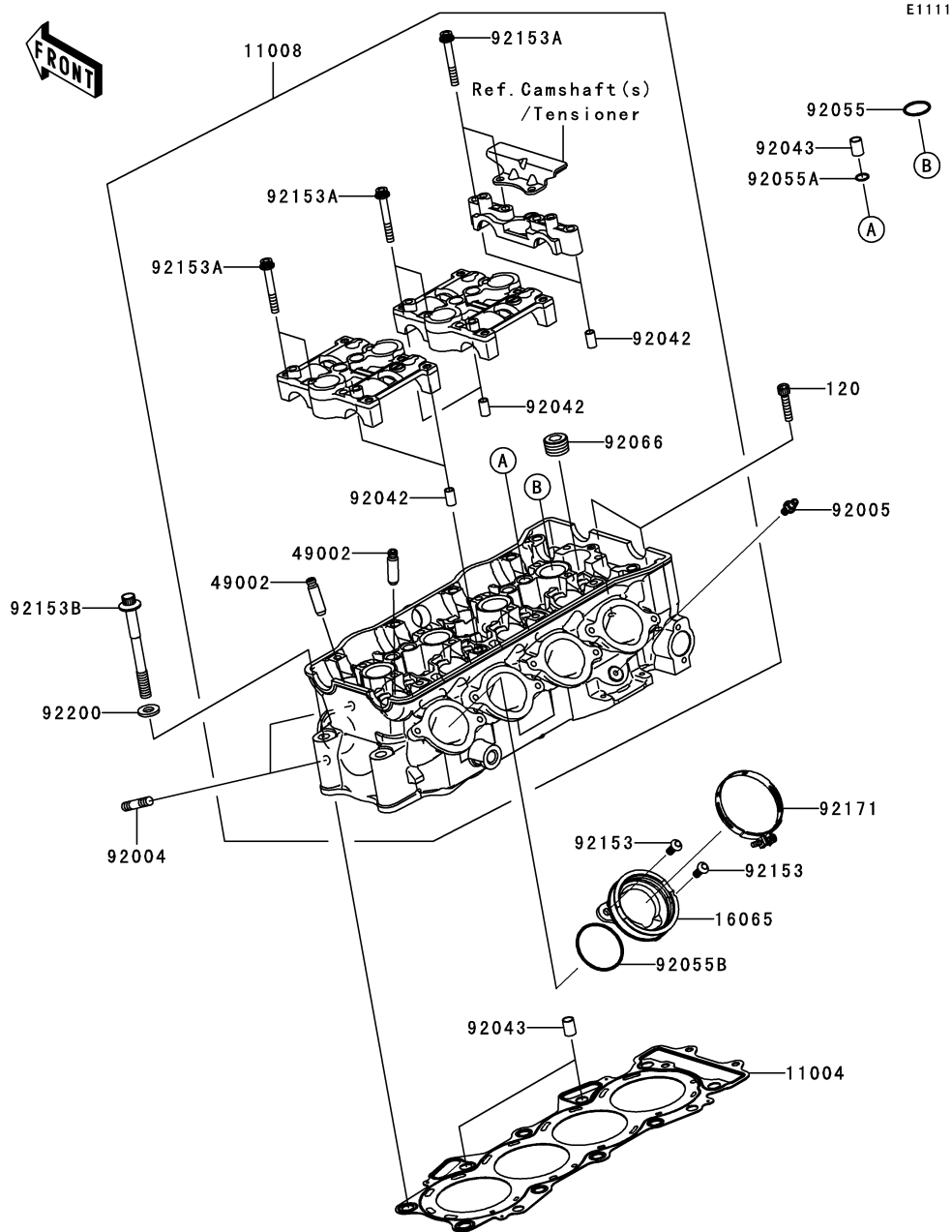

E1111

Ref. No.	Part No.	Description	Spec Code	Quantity-ZX600	
				'07	P7F
11004	11004-0057	GASKET-HEAD		1	
11008	11008-0095	HEAD-COMP-CYLINDER		1	
16065	16065-0035	HOLDER-CARBURETOR		4	
49002	49002-1152	GUIDE-VALVE		AR	
92004	92004-0025	STUD,8X22		8	
92005	92005-1273	FITTING		1	
92042	92042-007	PIN,DOWEL,6.3X8X14		6	
92043	92043-1264	PIN,8.2X10X14		6	
92055	92055-0074	RING-O,25.5X2		4	
92055A	92055-0133	RING-O,11.5X1.5		4	
92055B	92055-1536	RING-O,42X1.9		4	
92066	92066-0002	PLUG,PT1/2X12.5		4	
92153	92153-0406	BOLT,TORX,M6X14		8	
92153A	92153-0656	BOLT,SOCKET,6X45		20	
92153B	92153-1610	BOLT,FLANGED,9X90		10	
92171	92171-0729	CLAMP,60MM		4	
92200	92200-0193	WASHER,9.2X19X2.3		10	
120	120Z0630	BOLT-SOCKET,6X30		2	

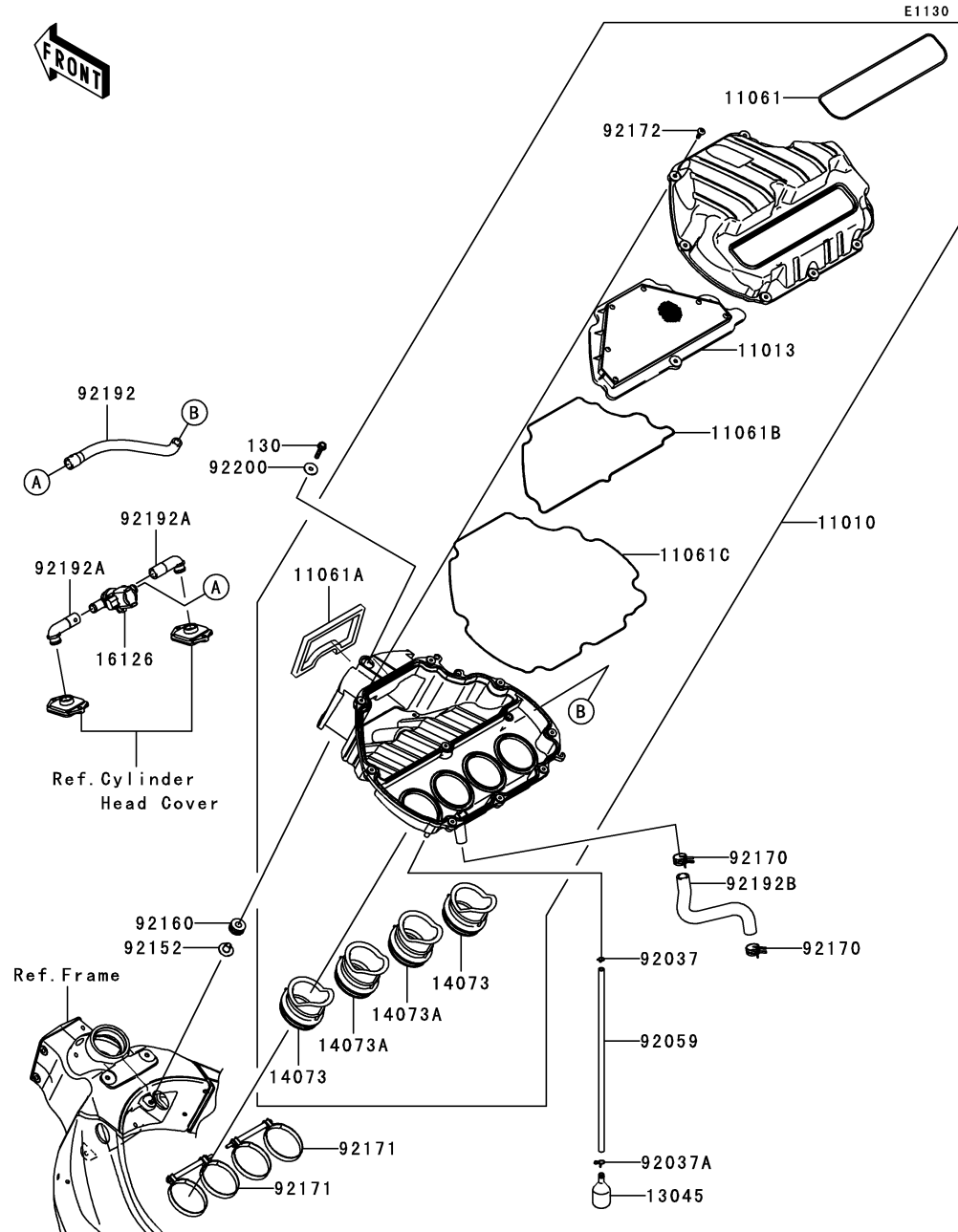

Ref. No.	Part No.	Description	Spec Code	Quantity-ZX600		
				'07		
				P7F		
11010	11010-0134	FILTER-ASSY-AIR	1			
11013	11013-0016	ELEMENT-AIR FILTER	1			
11061	11061-0242	GASKET,TOP INJECTOR	1			
11061A	11061-0243	GASKET,FRAME-A/C	1			
11061B	11061-0244	GASKET,ELEMENT-LWR CASE	1			
11061C	11061-0245	GASKET,A/C CASE	1			
13045	13045-1057	RECEIVER-OIL	1			
14073	14073-0151	DUCT,#1,#4	2			
14073A	14073-0152	DUCT,#2,#3	2			
16126	16126-1437	VALVE,AIR SWITING	1			
92037	92037-010	CLAMP,TUBE	1			
92037A	92037-1712	CLAMP	1			
92059	92059-103	TUBE,6X9X360	1			
92152	92152-0547	COLLAR,6.5X10.5X13.1	1			
92160	92160-1162	DAMPER	1			
92170	92170-1060	CLAMP	2			
92171	92171-0725	CLAMP	2			
92172	92172-1072	SCREW	9			
92192	92192-0347	TUBE,ASV-A/C	1			
92192A	92192-0348	TUBE,HEAD-ASV	2			
92192B	92192-0429	TUBE,BLOWBY	1			
92200	92200-1087	WASHER,6.5X22X1.6	1			
130	130L0630	BOLT-FLANGED,6X30	1			

This catalog covers:
'07 ZX600P7F Engine

GRID NO. This grid covers:

B-6

Air Duct

E1131

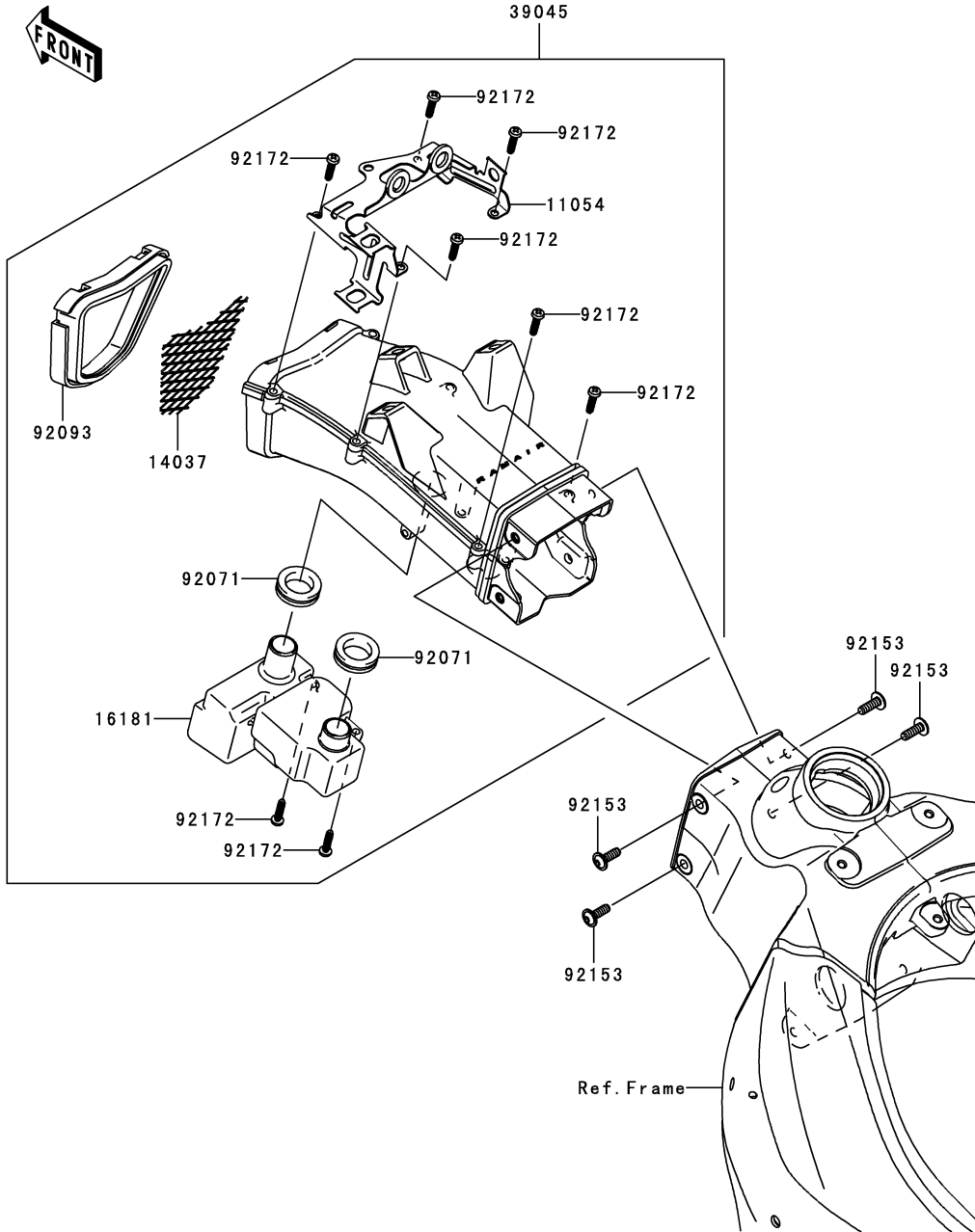

Ref. No.	Part No.	Description	Spec Code	Quantity-ZX600	
				'07	P7F
11054	11054-0753	BRACKET		1	
14037	14037-0057	SCREEN		1	
16181	16181-0011	TANK-RESONATOR		1	
39045	39045-0019	DUCT-ASSY, RAM		1	
92071	92071-3704	GROMMET		2	
92093	92093-0068	SEAL		1	
92153	92153-0875	BOLT, 6X18		4	
92172	92172-0009	SCREW, TAPPING, 5X20		8	

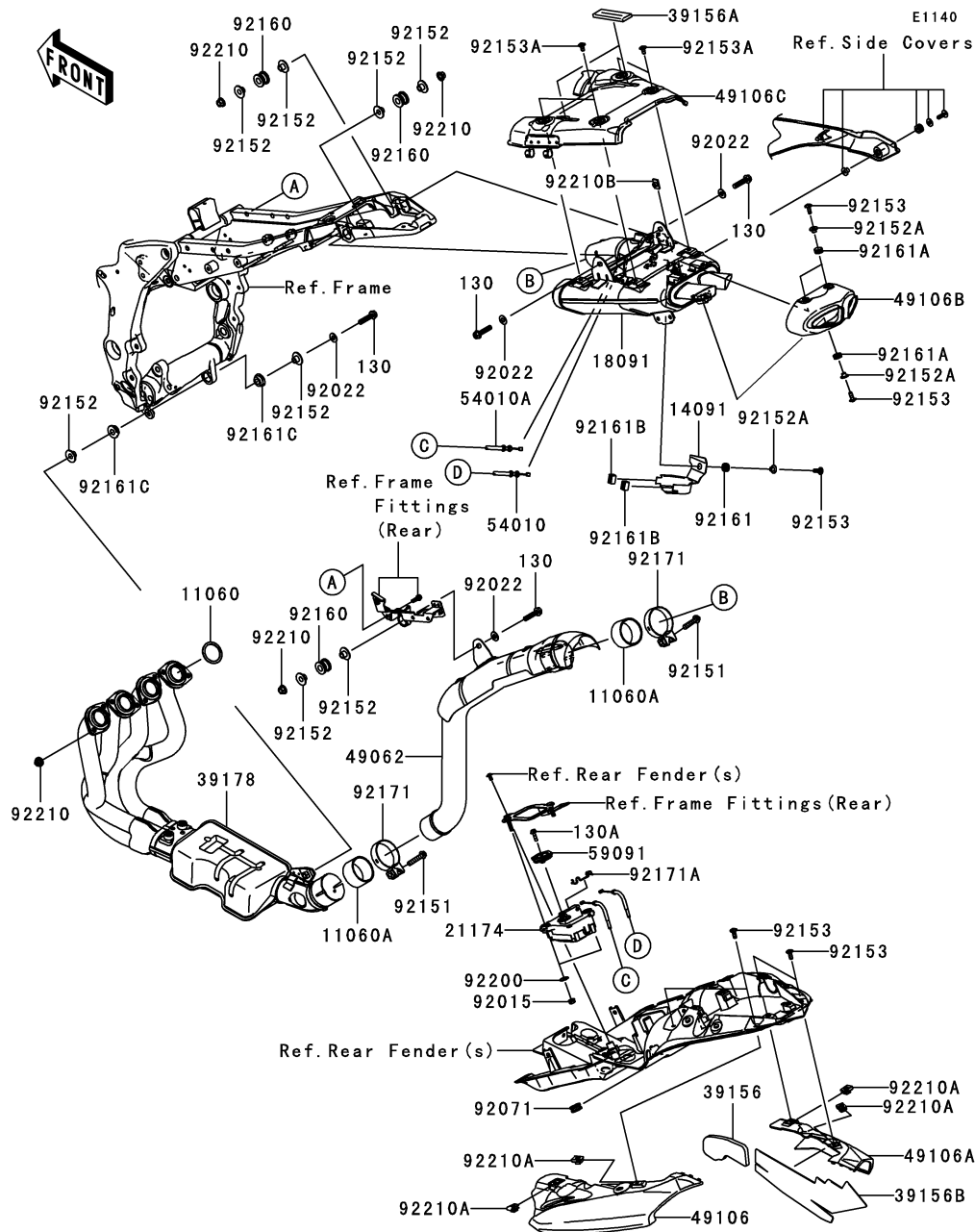

Ref. No.	Part No.	Description	Spec Code	Quantity-ZX600	
				'07	P7F
11060	11060-1203	GASKET,EXHAUST PIPE		4	
11060A	11060-1330	GASKET,EXHAUST PIPE HOLDER		2	
14091	14091-0792	COVER,PULLEY		1	
18091	18091-0329	BODY-COMP-MUFFLER		1	
21174	21174-0003	MOTOR-ELECTRIC		1	
39156	39156-0276	PAD,SIDE COVER,RH		1	
39156A	39156-0278	PAD,SILENCER BRACKET		2	
39156B	39156-0279	PAD,HEAT GUARD		1	
39178	39178-0068	MANIFOLD-COMP-EXHAUST		1	
49062	49062-0033	PIPE-COMP-EXHAUST		1	
49106	49106-0055	COVER-MUFFLER,SIDE,LH		1	
49106A	49106-0056	COVER-MUFFLER,SIDE,RH		1	
49106B	49106-0058	COVER-MUFFLER,TAIL END		1	
49106C	49106-0059	COVER-MUFFLER,UPP		1	
54010	54010-0072	CABLE,WHITE		1	
54010A	54010-0073	CABLE,BLACK		1	
59091	59091-0007	PULLEY		1	
92015	92015-1367	NUT,FLANGED,6MM		2	
92022	92022-3730	WASHER,8.5X19X1.2		4	
92071	92071-0011	GROMMET		1	
92151	92151-1532	BOLT,FLANGED,8X40		2	
92152	92152-0188	COLLAR		8	
92152A	92152-0286	COLLAR		4	
92153	92153-0817	BOLT,8X16		8	
92153A	92153-1275	BOLT,SOCKET,6X12		4	
92160	92160-1116	DAMPER,MUFFLER MOUNT		3	
92161	92161-0308	DAMPER		1	
92161A	92161-0419	DAMPER,8.3X16X6.4		3	
92161B	92161-0475	DAMPER		2	
92161C	92161-0532	DAMPER,MANIFOLD MOUNT		2	
92171	92171-0133	CLAMP		2	
92171A	92171-0292	CLAMP		1	
92200	92200-0078	WASHER		2	
92210	92210-0121	NUT,8MM		11	
92210A	92210-0130	NUT		4	
92210B	92210-1352	NUT,PLATE,6MM		1	
130	130CD0835	BOLT-FLANGED,8X35		4	
130A	130L0518	BOLT-FLANGED,5X18		1	

E1210

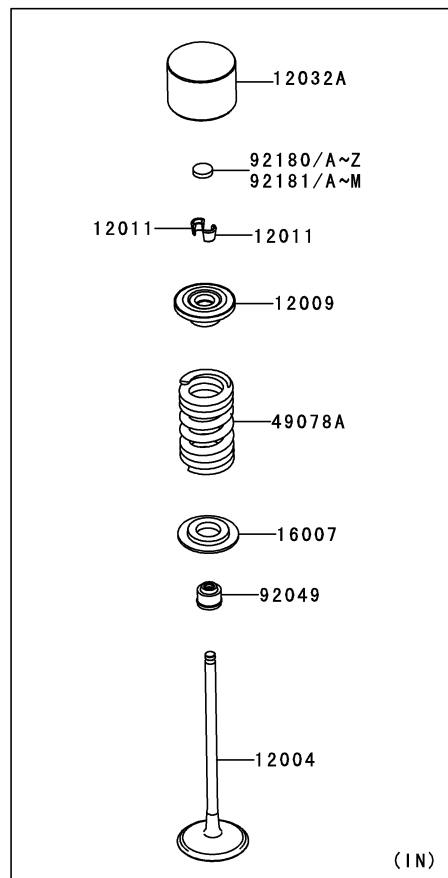
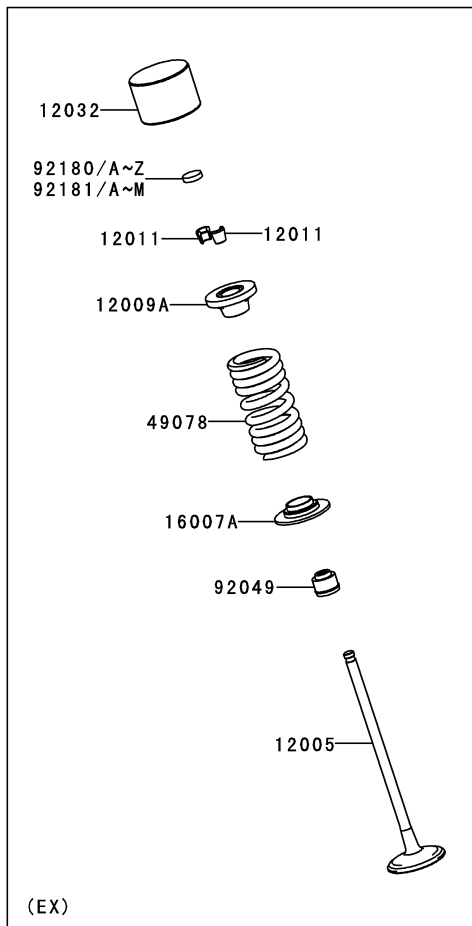

Ref. No.	Part No.	Description	Spec Code	Quantity-ZX600			
				'07			
				P7F			
12004	12004-0022	VALVE-INTAKE		8			
12005	12005-0041	VALVE-EXHAUST		8			
12009	12009-0013	RETAINER-VALVE SPRING,INTAKE		8			
12009A	12009-0014	RETAINER-VALVE SPRING,EXHAUST		8			
12011	12011-1052	COLLET		32			
12032	12032-0008	TAPPET		8			
12032A	12032-0009	TAPPET		8			
16007	16007-0003	SEAT-SPRING		8			
16007A	16007-1227	SEAT-SPRING		8			
49078	49078-0052	SPRING-ENGINE VALVE,EXHAUST		8			
49078A	49078-0063	SPRING-ENGINE VALVE,INTAKE		8			
92049	92049-1308	SEAL-OIL, VALVE GUIDE		16			
92180	92180-0108	SHIM,T=1.300		16			
92180A	92180-0109	SHIM,T=1.325		AR			
92180B	92180-0110	SHIM,T=1.350		AR			
92180C	92180-0111	SHIM,T=1.375		AR			
92180D	92180-0112	SHIM,T=1.400		AR			
92180E	92180-0113	SHIM,T=1.425		AR			
92180F	92180-0114	SHIM,T=1.450		AR			
92180G	92180-0115	SHIM,T=1.475		AR			
92180H	92180-0116	SHIM,T=1.500		AR			
92180I	92180-0117	SHIM,T=1.525		AR			
92180J	92180-0118	SHIM,T=1.550		AR			
92180K	92180-0119	SHIM,T=1.575		AR			
92180L	92180-0120	SHIM,T=1.600		AR			
92180M	92180-0121	SHIM,T=1.625		AR			
92180N	92180-0122	SHIM,T=1.650		AR			
92180O	92180-0123	SHIM,T=1.675		AR			
92180P	92180-0124	SHIM,T=1.700		AR			
92180Q	92180-0125	SHIM,T=1.725		AR			
92180R	92180-0126	SHIM,T=1.750		AR			
92180S	92180-0127	SHIM,T=1.775		AR			
92180T	92180-0128	SHIM,T=1.800		AR			
92180U	92180-0129	SHIM,T=1.825		AR			
92180V	92180-0130	SHIM,T=1.850		AR			
92180W	92180-0131	SHIM,T=1.875		AR			
92180X	92180-0132	SHIM,T=1.900		AR			
92180Y	92180-0133	SHIM,T=1.925		AR			
92180Z	92180-0134	SHIM,T=1.950		AR			

E1210

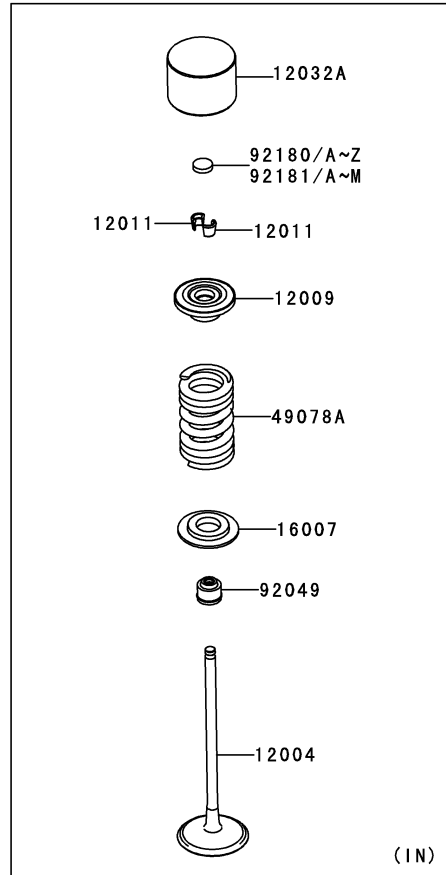
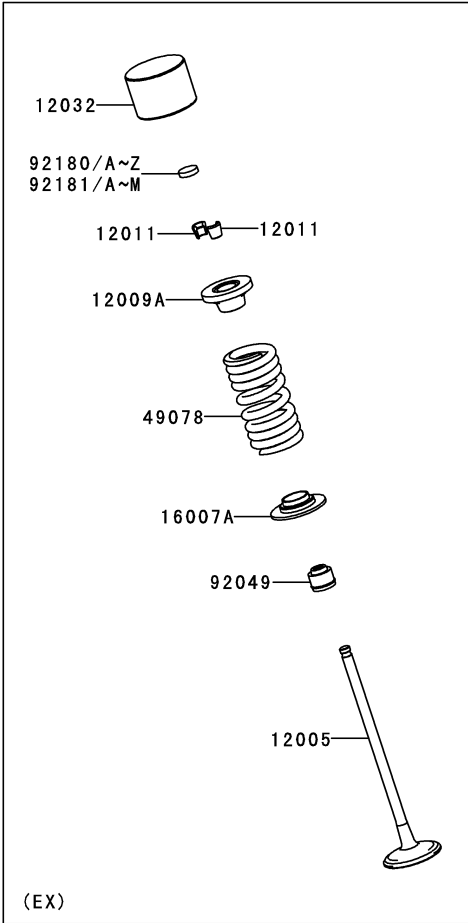

Ref. No.	Part No.	Description	Spec Code	Quantity-ZX600			
				'07			
				P7F			
92181	92180-0135	SHIM,T=1.975	AR				
92181A	92180-0136	SHIM,T=2.000	AR				
92181B	92180-0137	SHIM,T=2.025	AR				
92181C	92180-0138	SHIM,T=2.050	AR				
92181D	92180-0139	SHIM,T=2.075	AR				
92181E	92180-0140	SHIM,T=2.100	AR				
92181F	92180-0141	SHIM,T=2.125	AR				
92181G	92180-0142	SHIM,T=2.150	AR				
92181H	92180-0143	SHIM,T=2.175	AR				
92181I	92180-0144	SHIM,T=2.200	AR				
92181J	92180-0145	SHIM,T=2.225	AR				
92181K	92180-0146	SHIM,T=2.250	AR				
92181L	92180-0147	SHIM,T=2.275	AR				
92181M	92180-0148	SHIM,T=2.300	AR				

E1230

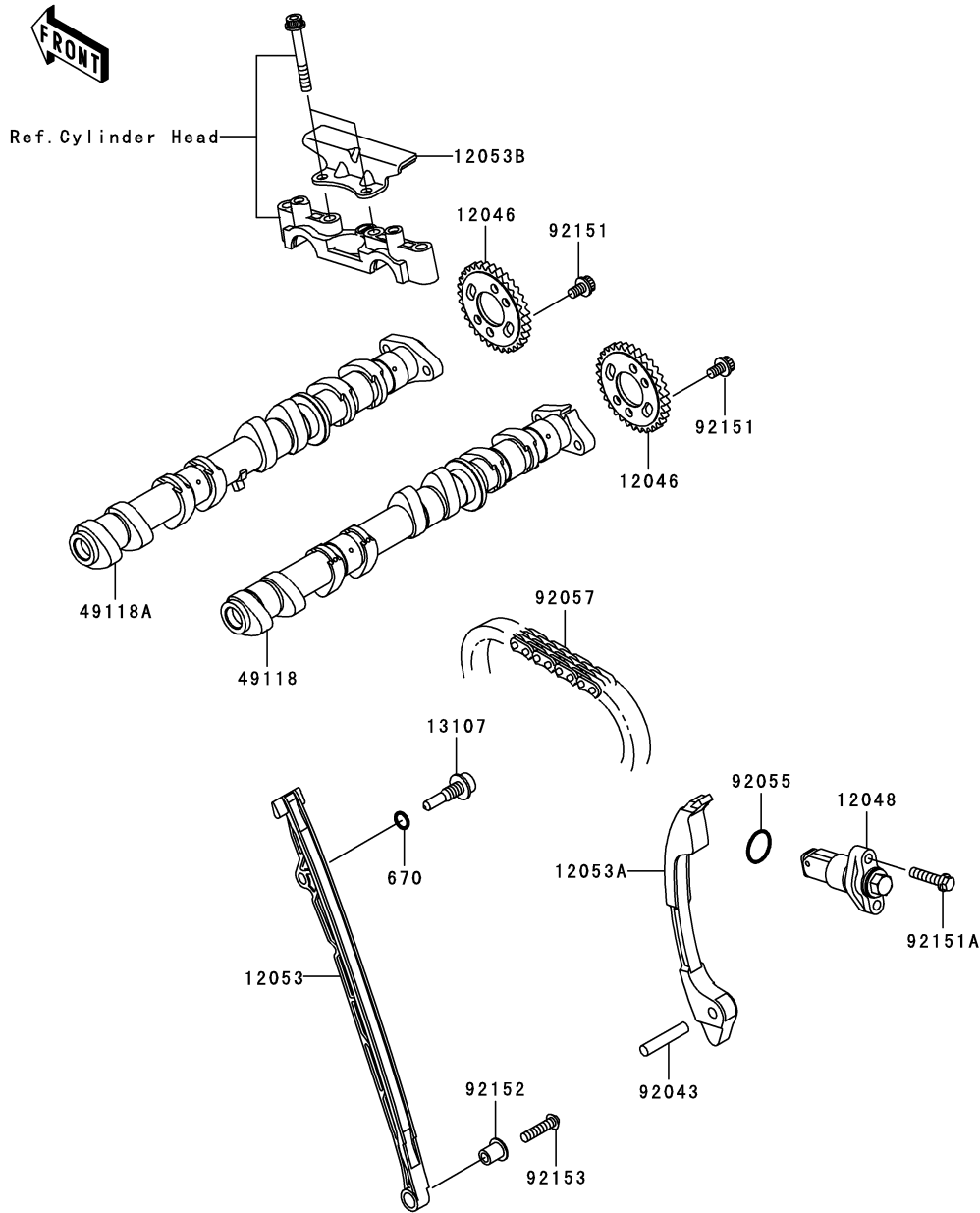

Ref. No.	Part No.	Description	Spec Code	Quantity-ZX600		
				'07		
			P7F			
12046	12046-0053	SPROCKET,32T				2
12048	12048-1181	TENSIONER-ASSY				1
12053	12053-0084	GUIDE-CHAIN,FR				1
12053A	12053-0085	GUIDE-CHAIN,RR				1
12053B	12053-0086	GUIDE-CHAIN,UPP				1
13107	13107-0157	SHAFT,CHAIN GUIDE				1
49118	49118-0103	CAMSHAFT-COMP,INTAKE				1
49118A	49118-0104	CAMSHAFT-COMP,EXHAUST				1
92043	92043-0114	PIN,7X36.4				1
92055	92055-086	RING-O,18.8X1.9				1
92057	92057-1531	CHAIN,CAM				1
92151	92151-1829	BOLT,SOCKET,6X10				4
92151A	92151-1930	BOLT,FLANGED-SMALL,6X25				2
92152	92152-0413	COLLAR				1
92153	92153-1640	BOLT,TORX,6X25				1
670	670D1509	O RING,9MM				1

E1320

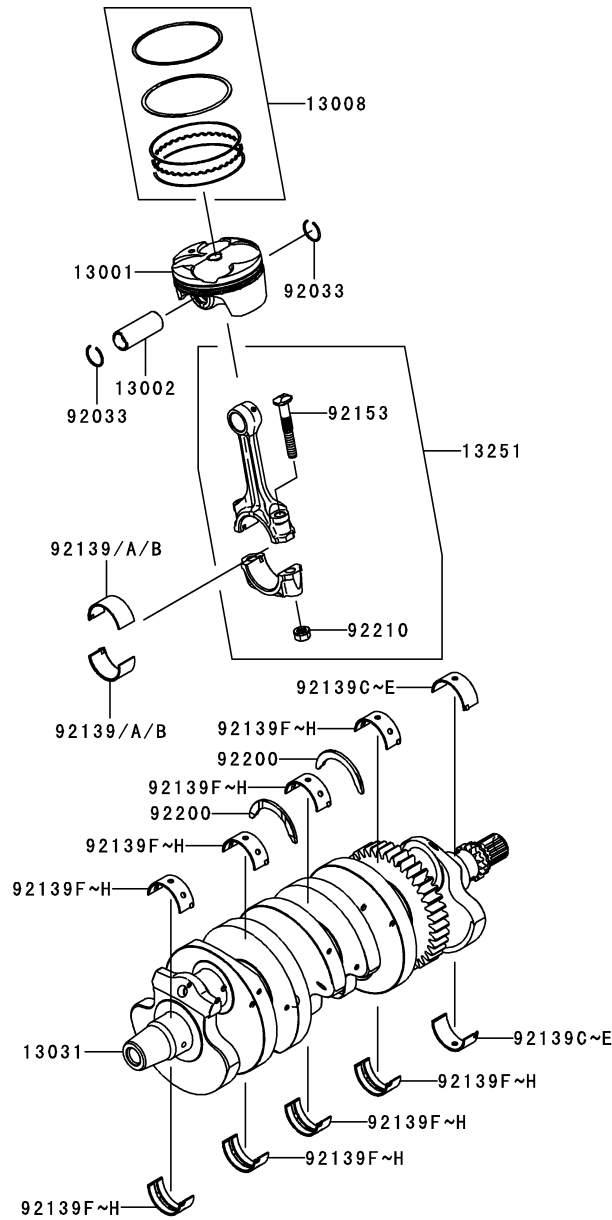

Ref. No.	Part No.	Description	Spec Code	Quantity-ZX600			
				'07			
13001	13001-0081	PISTON-ENGINE		4			
13002	13002-0015	PIN-PISTON		4			
13008	13008-0023	RING-SET-PISTON		4			
13031	13031-0075	CRANKSHAFT-COMP		1			
13251	13251-0018-JJ	ROD-ASSY-CONNECTING,J		AR			
92033	92033-1151	RING-SNAP,PISTON PIN		8			
92139	92139-0165	BUSHING,CRANK PIN,BLUE		AR			
92139A	92139-0166	BUSHING,CRANK PIN,BLACK		8			
92139B	92139-0167	BUSHING,CRANK PIN,BROWN		AR			
92139C	92139-0171	BUSHING,CRANK #5,BLUE		AR			
92139D	92139-0172	BUSHING,CRANK #5,BLACK		2			
92139E	92139-0173	BUSHING,CRANK #5,BROWN		AR			
92139F	92139-0189	BUSHING,CRANK #1,BLUE		AR			
92139G	92139-0190	BUSHING,CRANK #1,BLK		8			
92139H	92139-0191	BUSHING,CRANK #1,BRN		AR			
92153	92153-1172	BOLT,7MM		8			
92200	92200-0383	WASHER,T=2.5		2			
92210	92210-0384	NUT,CONNECTING ROD,7MM		8			

E1350

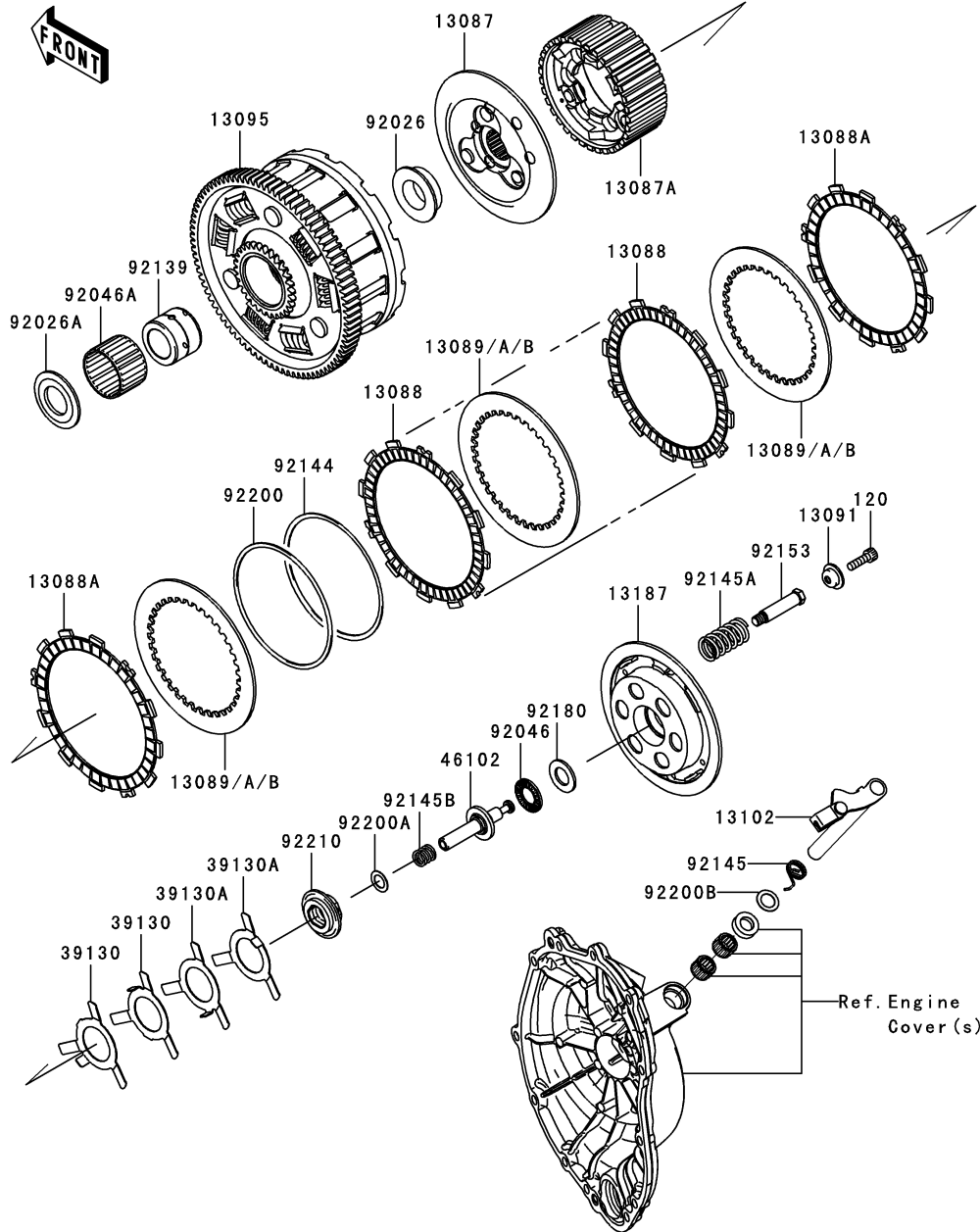

Ref. No.	Part No.	Description	Spec Code	Quantity-ZX600	
				'07	P7F
13087	13087-0019	HUB-CLUTCH		1	
13087A	13087-0020	HUB-CLUTCH		1	
13088	13088-0003	PLATE-FRICTION		6	
13088A	13088-0025	PLATE-FRICTION		2	
13089	13089-0008	PLATE-CLUTCH,T=2.3		AR	
13089A	13089-0009	PLATE-CLUTCH,T=2.6		7	
13089B	13089-1093	PLATE-CLUTCH,T=2.9		AR	
13091	13091-1041	HOLDER,CLUTCH SPRING		6	
13095	13095-0063	HOUSING-COMP-CLUTCH		1	
13102	13102-0032	RELEASE-COMP-CLUTCH		1	
13187	13187-0011	PLATE-CLUTCH OPERATING		1	
39130	39130-1078	SPRING-LEAF		2	
39130A	39130-1079	SPRING-LEAF		2	
46102	46102-0090	ROD		1	
92026	92026-0022	SPACER		1	
92026A	92026-1356	SPACER		1	
92046	92046-1052	BEARING-NEEDLE,AXK1102		1	
92046A	92046-1263	BEARING-NEEDLE,K38X43X28.8X		1	
92139	92139-0067	BUSHING,25X38X29.05		1	
92144	92144-1854	SPRING,FRICTION PLATE		1	
92145	92145-0485	SPRING		1	
92145A	92145-0486	SPRING		6	
92145B	92145-1159	SPRING,ROD		1	
92153	92153-0797	BOLT		6	
92180	92180-0149	SHIM,15.3X27.5X2.0		1	
92200	92200-1260	WASHER,FRICTION PLATE		1	
92200A	92200-1423	WASHER,11.2X18X0.5		1	
92200B	92200-1487	WASHER,12X18.5X0.5		1	
92210	92210-0152	NUT		1	
120	120Q0620	BOLT-SOCKET,6X20		6	

This catalog covers:
'07 ZX600P7F Engine

GRID NO. This grid covers:
B-13 Transmission

E1361

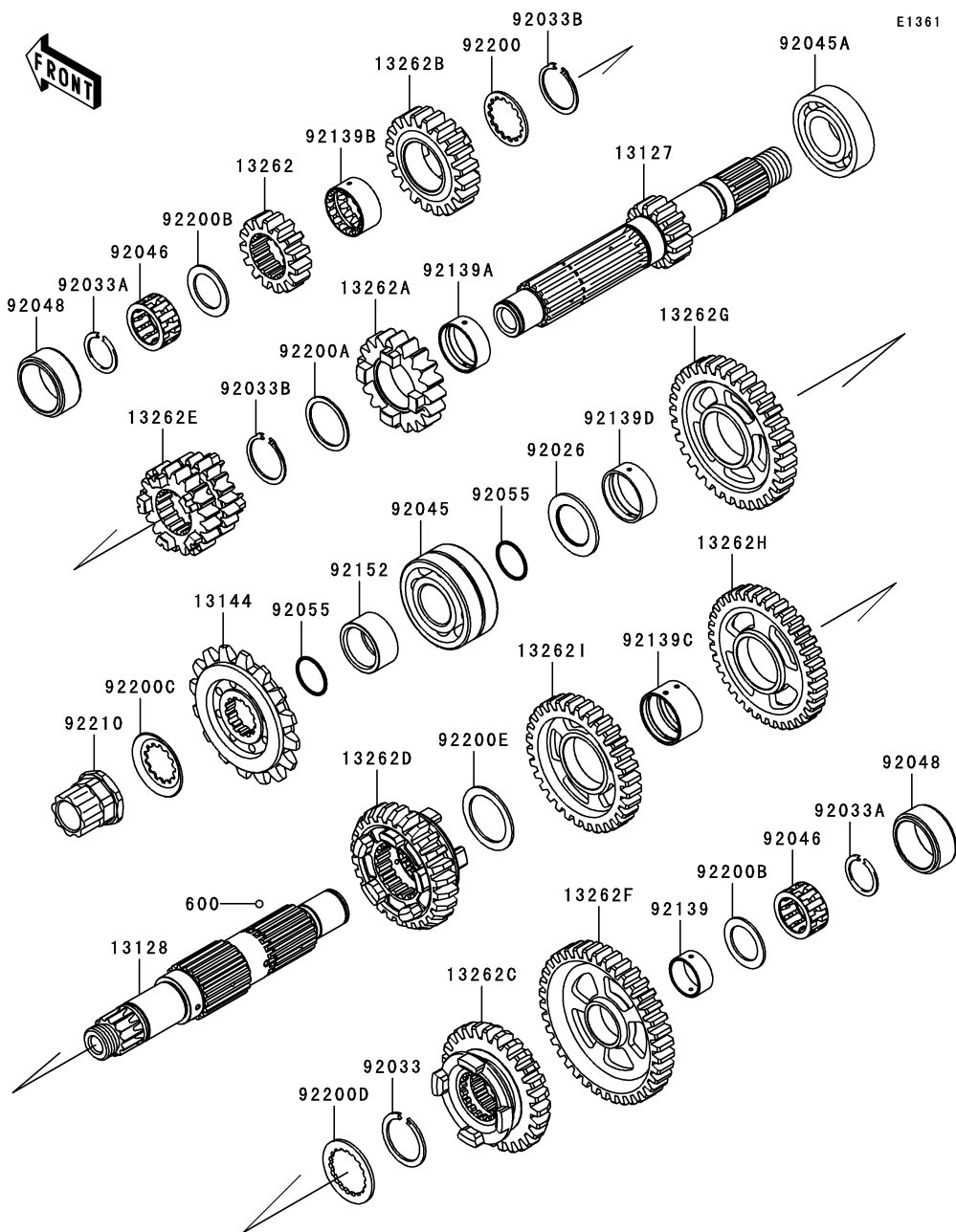

Ref. No.	Part No.	Description	Spec Code	Quantity-ZX600		
				'07	P7F	
13127	13127-0044	SHAFT-TRANSMISSION INPUT,14T			1	
13128	13128-0031	SHAFT-TRANSMISSION OUTPUT			1	
13144	13144-0038	SPROCKET-OUTPUT,16T,#520			1	
13262	13262-0372	GEAR,INPUT 2ND,15T			1	
13262A	13262-0374	GEAR,INPUT 5TH,19T			1	
13262B	13262-0375	GEAR,INPUT 6TH,20T			1	
13262C	13262-0380	GEAR,OUTPUT 5TH,27T			1	
13262D	13262-0381	GEAR,OUTPUT 6TH,26T			1	
13262E	13262-0506	GEAR,INPUT 3RD&4TH,20T&20T			1	
13262F	13262-0507	GEAR,OUTPUT LOW,38T			1	
13262G	13262-0508	GEAR,OUTPUT 2ND,33T			1	
13262H	13262-0509	GEAR,OUTPUT 3RD,37T			1	
13262I	13262-0510	GEAR,OUTPUT 4TH,32T			1	
92026	92026-1529	SPACER,25.3X39X2.0			1	
92033	92033-0047	RING-SNAP,26.9X34X1.5			1	
92033A	92033-025	RING-SNAP,20X25.5X1.2			2	
92033B	92033-1037	RING-SNAP,25.9X30.6X1.2			2	
92045	92045-0003	BEARING-BALL,DAC2557NSSH			1	
92045A	92045-0058	BEARING-BALL,25X52X15			1	
92046	92046-1291	BEARING-NEEDLE			2	
92048	92048-0005	RACE,30X38X17.3			2	
92055	92055-1293	RING-O,21.5X1.5			2	
92139	92139-0038	BUSHING,GEAR,LOW OUT			1	
92139A	92139-0161	BUSHING,GEAR,5TH IN			1	
92139B	92139-0162	BUSHING,GEAR,6TH IN			1	
92139C	92139-0163	BUSHING,GEAR,3RD/4TH OUT			1	
92139D	92139-0164	BUSHING,GEAR,2ND OUT			1	
92152	92152-0444	COLLAR,25X32X15.7			1	
92200	92200-0050	WASHER,28.3X34.0X1.6			1	
92200A	92200-0051	WASHER,28.1X34.0X1.2			1	
92200B	92200-0138	WASHER,22.1X32.0X1.4			2	
92200C	92200-1065	WASHER			1	
92200D	92200-1277	WASHER,TOOTHED,28X40X2			1	
92200E	92200-1278	WASHER,29.9X40X1.5			1	
92210	92210-0323	NUT,20MM			1	
600	600A0500	BALL-STEEL,5/32"			3	

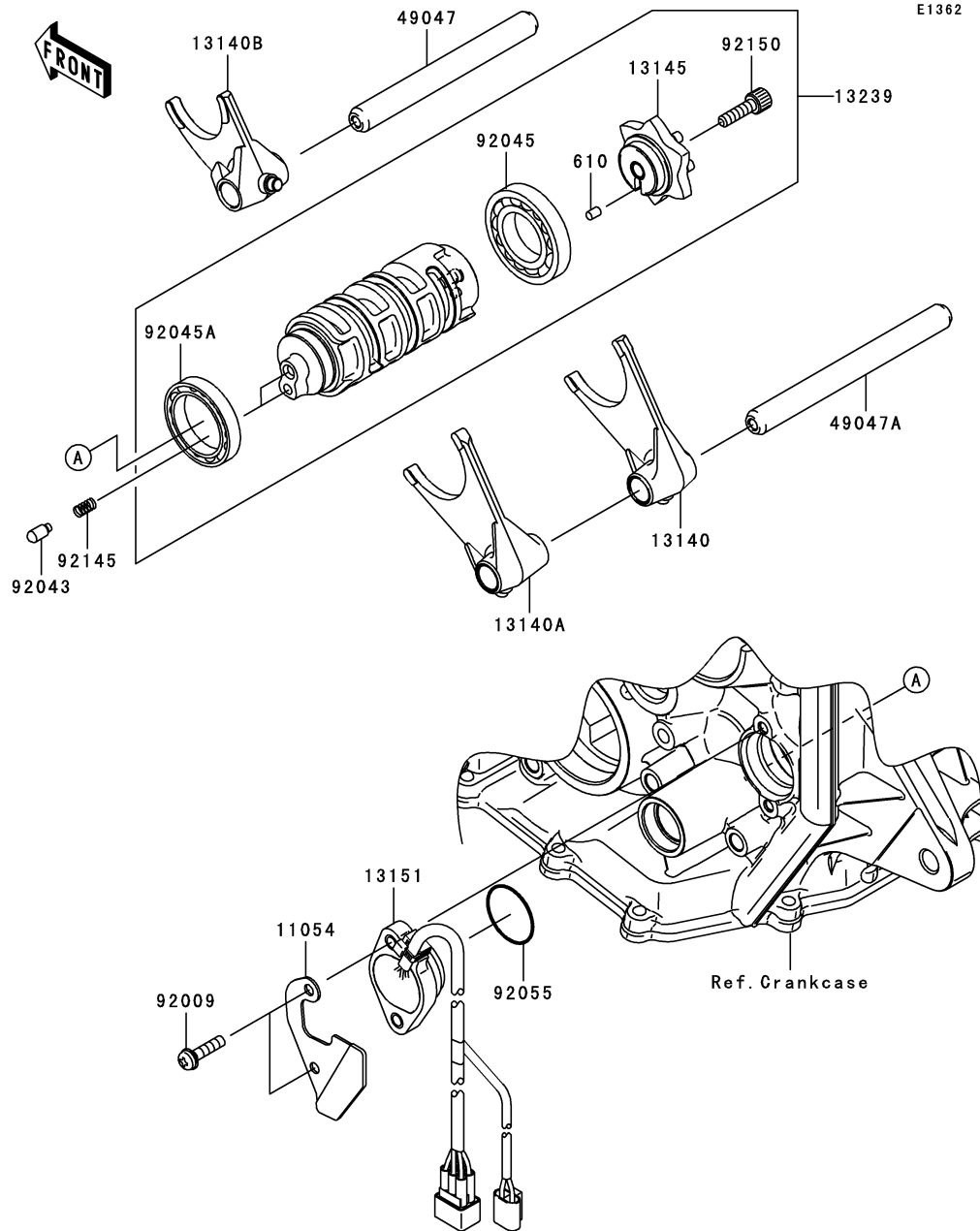

E1362

Ref. No.	Part No.	Description	Spec Code	Quantity-ZX600	
				'07	P7F
11054	11054-1840	BRACKET			1
13140	13140-0041	FORK-SHIFT,OUTPUT,RH			1
13140A	13140-0042	FORK-SHIFT,OUTPUT,LH			1
13140B	13140-0048	FORK-SHIFT,INPUT			1
13145	13145-0029	CAM-CHANGE DRUM			1
13151	13151-0023	SWITCH-COMP,NEUTRAL			1
13239	13239-0024	DRUM-ASSY-CHANGE			1
49047	49047-0026	ROD-SHIFT,INPUT			1
49047A	49047-0027	ROD-SHIFT,OUTPUT			1
92009	92009-1905	SCREW,PAN-WP-CROS,5X20			2
92043	92043-1654	PIN			2
92045	92045-1045	BEARING-BALL,16005(NTN)			1
92045A	92045-1152	BEARING-BALL,6806			1
92055	92055-091	RING-O			1
92145	92145-1414	SPRING			2
92150	92150-1880	BOLT,SOCKET,6X20			1
610	610A0406	ROLLER,4X6			1

E1370

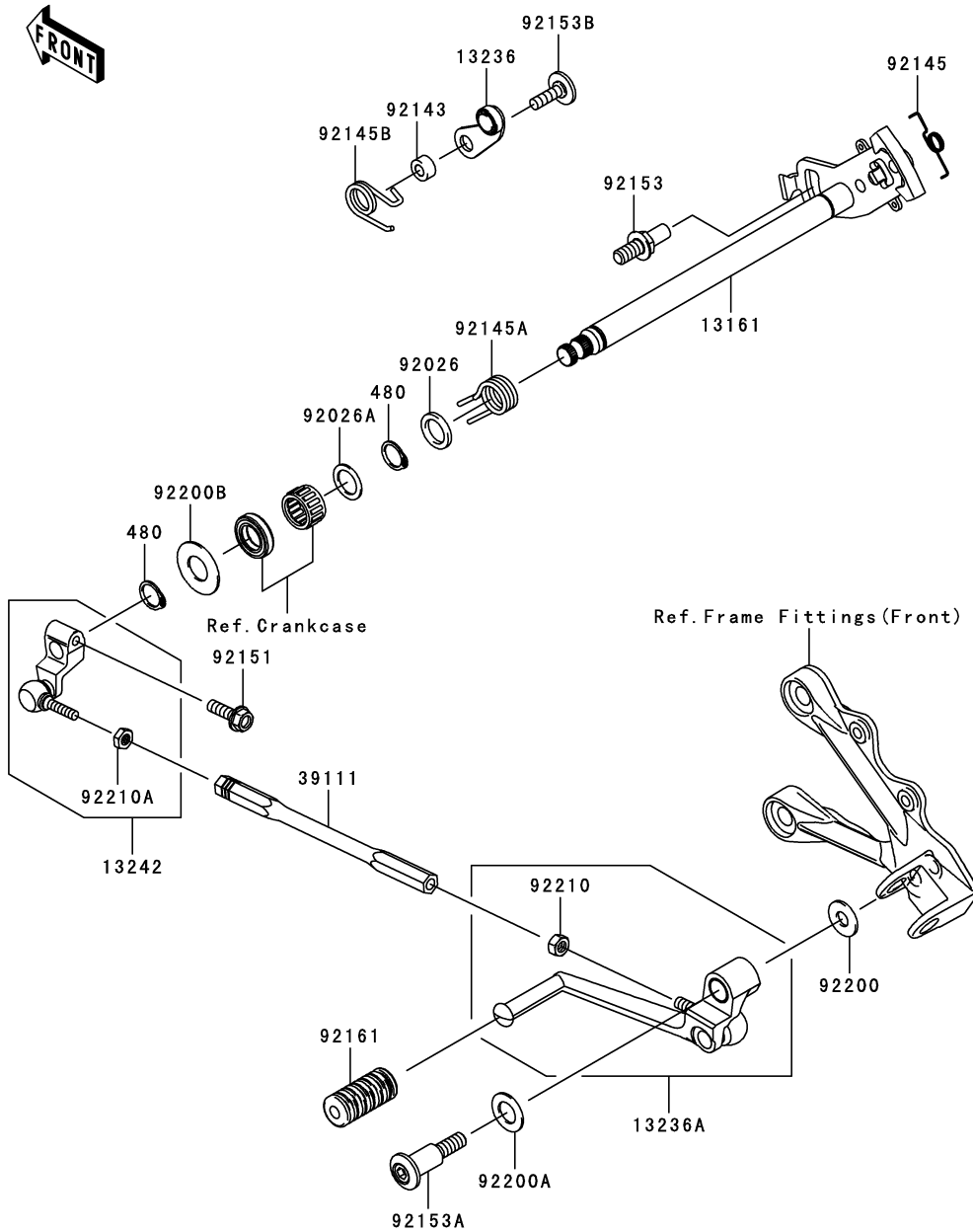

Ref. No.	Part No.	Description	Spec Code	Quantity-ZX600	
				'07	P7F
13161	13161-0054	LEVER-COMP-CHANGE SHAFT		1	
13236	13236-0114	LEVER-COMP,POSITION		1	
13236A	13236-0122	LEVER-COMP,CHANGE PEDAL		1	
13242	13242-0029	LEVER-ASSY-CHANGE		1	
39111	39111-0039	ROD-TIE,L=115		1	
92026	92026-0107	SPACER,14X20X2.3		1	
92026A	92026-1534	SPACER,14X20X1.0		1	
92143	92143-1595	COLLAR		1	
92145	92145-0414	SPRING		1	
92145A	92145-0415	SPRING,RETURN		1	
92145B	92145-0416	SPRING,DRUM POSITION		1	
92151	92151-1226	BOLT,FLANGED,6X20		1	
92153	92153-0421	BOLT,RETURN SPRING		1	
92153A	92153-0880	BOLT,8X41		1	
92153B	92153-1505	BOLT,6X20		1	
92161	92161-1300	DAMPER,CHANGE PEDAL		1	
92200	92200-0198	WASHER,8.5X20X1.5		1	
92200A	92200-0199	WASHER,12.5X22X1.2		1	
92200B	92200-0265	WASHER		1	
92210	92210-1100	NUT,6MM		1	
92210A	92210-1101	NUT,LEFT HANDED,6MM		1	
480	480J1400	CIRCLIP-TYPE-C,14MM		2	

This catalog covers:
'07 ZX600P7F Engine

GRID NO. **C-4** This grid covers:
Crankcase

E1411

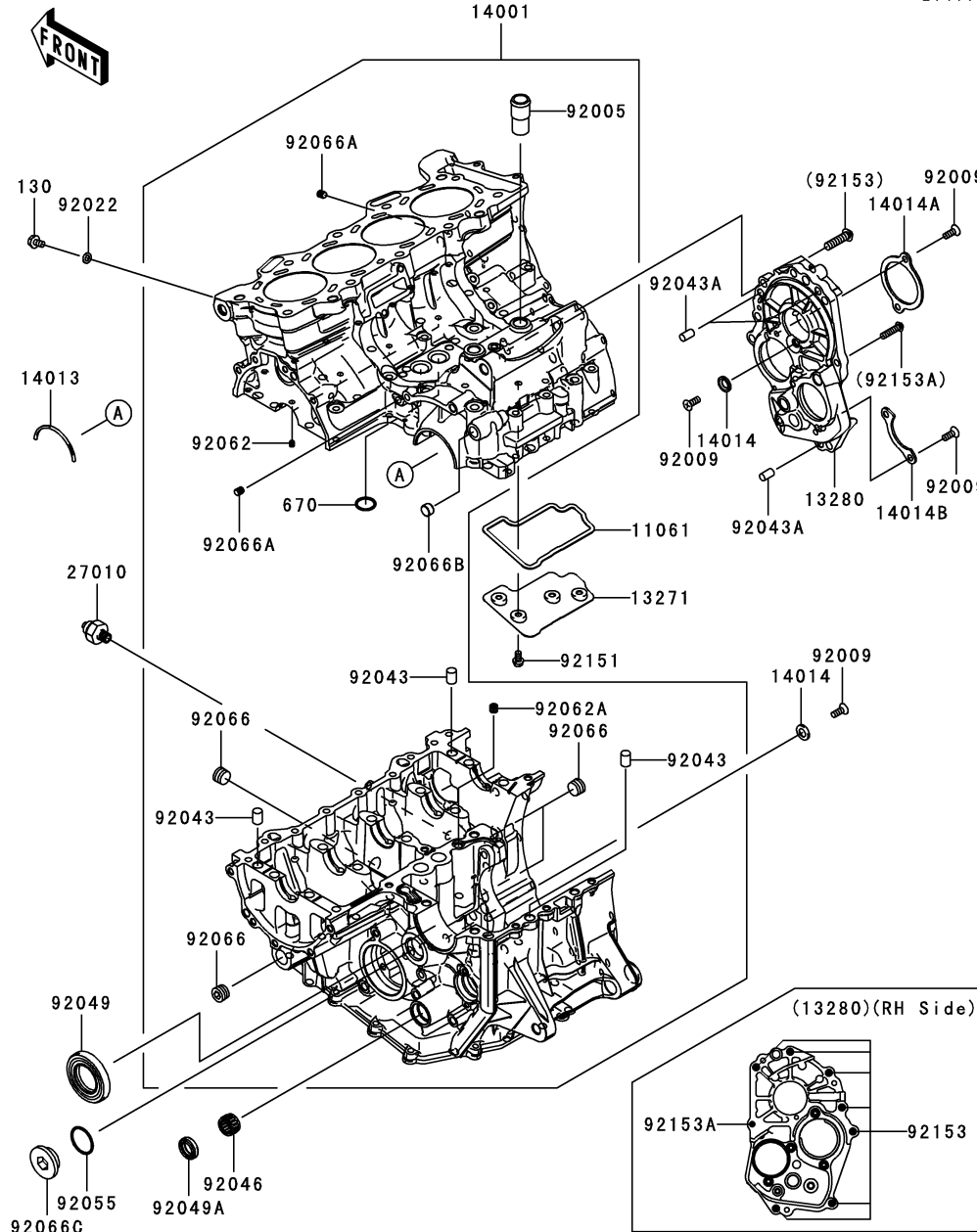

Ref. No.	Part No.	Description	Spec Code	Quantity-ZX600	
				'07	P7F
11061	11061-0291	GASKET,BREATHER ROOM			1
13271	13271-0795	PLATE,BREATHER ROOM			1
13280	13280-0199	HOLDER,TRANSMISSION			1
14001	14001-0112	SET-CRANKCASE			1
14013	14013-1051	RING-POSITION			1
14014	14014-0019	PLATE-POSITION,9.5X17X2.3			2
14014A	14014-0029	PLATE-POSITION			1
14014B	14014-0030	PLATE-POSITION			1
27010	27010-1313	SWITCH,OIL PRESSURE			1
92005	92005-1238	FITTING,BREATHER			1
92009	92009-1360	SCREW,6X16			6
92022	92022-304	WASHER,6.2X11X1			1
92043	92043-1506	PIN,10X14			3
92043A	92043-1567	PIN,8X14			3
92046	92046-037	BEARING-NEEDLE,7E-HK1412			1
92049	92049-1474	SEAL-OIL,TC32578			1
92049A	92049-1520	SEAL-OIL,TC14245			1
92055	92055-091	RING-O			1
92062	92062-0004	NOZZLE			4
92062A	92062-1056	NOZZLE			1
92066	92066-0003	PLUG,PT3/8X10			4
92066A	92066-1012	PLUG,OIL LINE,7.2X8			2
92066B	92066-1110	PLUG			1
92066C	92066-1161	PLUG,25X8			1
92151	92151-1389	BOLT,FLANGED-SMALL,6X10			4
92153	92153-1639	BOLT,TORX,8X30			7
92153A	92153-1640	BOLT,TORX,6X25			1
130	130Y0610	BOLT-FLANGED,6X10			1
670	670D2018	O RING			2

E1412

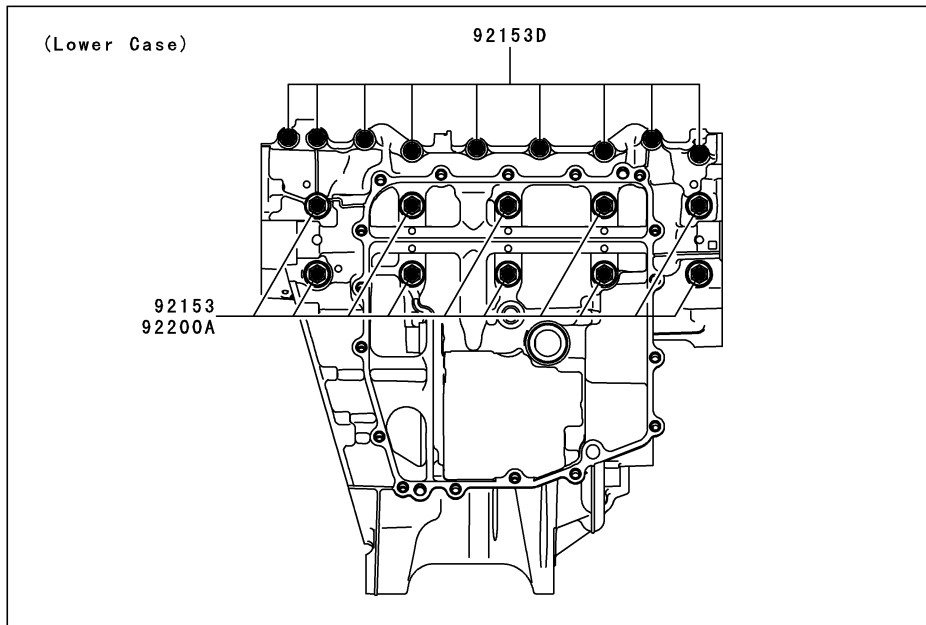
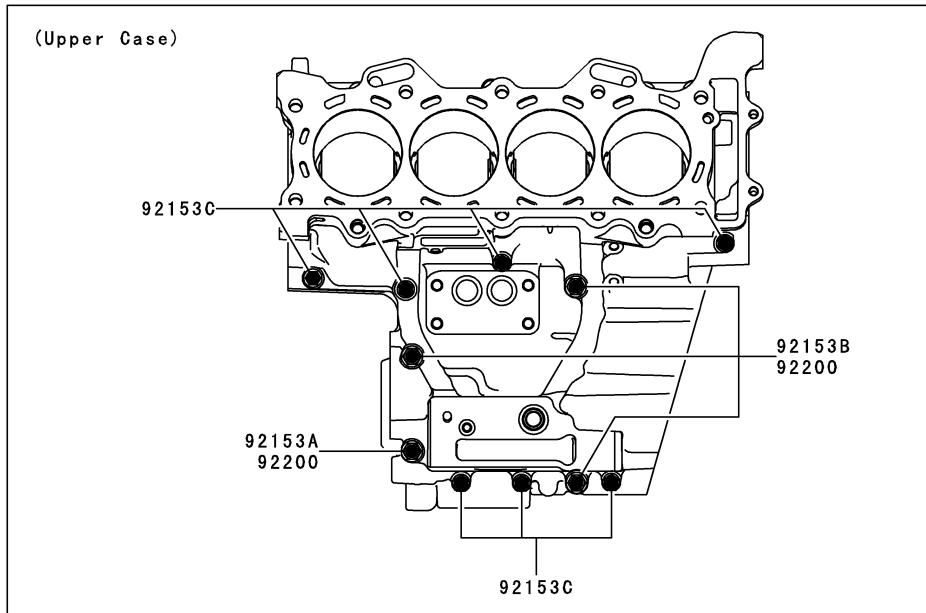

Ref. No.	Part No.	Description	Spec Code	Quantity-ZX600			
				'07			
92153	92153-1631	BOLT,FLANGED,8X95		10			
92153A	92153-1632	BOLT,FLANGED,8X90		1			
92153B	92153-1633	BOLT,FLANGED,8X75		3			
92153C	92153-1637	BOLT,FLANGED,6X68		7			
92153D	92153-1638	BOLT,FLANGED,6X50		9			
92200	92200-0047	WASHER,8.2X16X1.6		4			
92200A	92200-0153	WASHER,8.5X18X3.0		10			

This catalog covers:
'07 ZX600P7F Engine

GRID NO. **C-6** This grid covers:
Engine Cover(s)

E1431

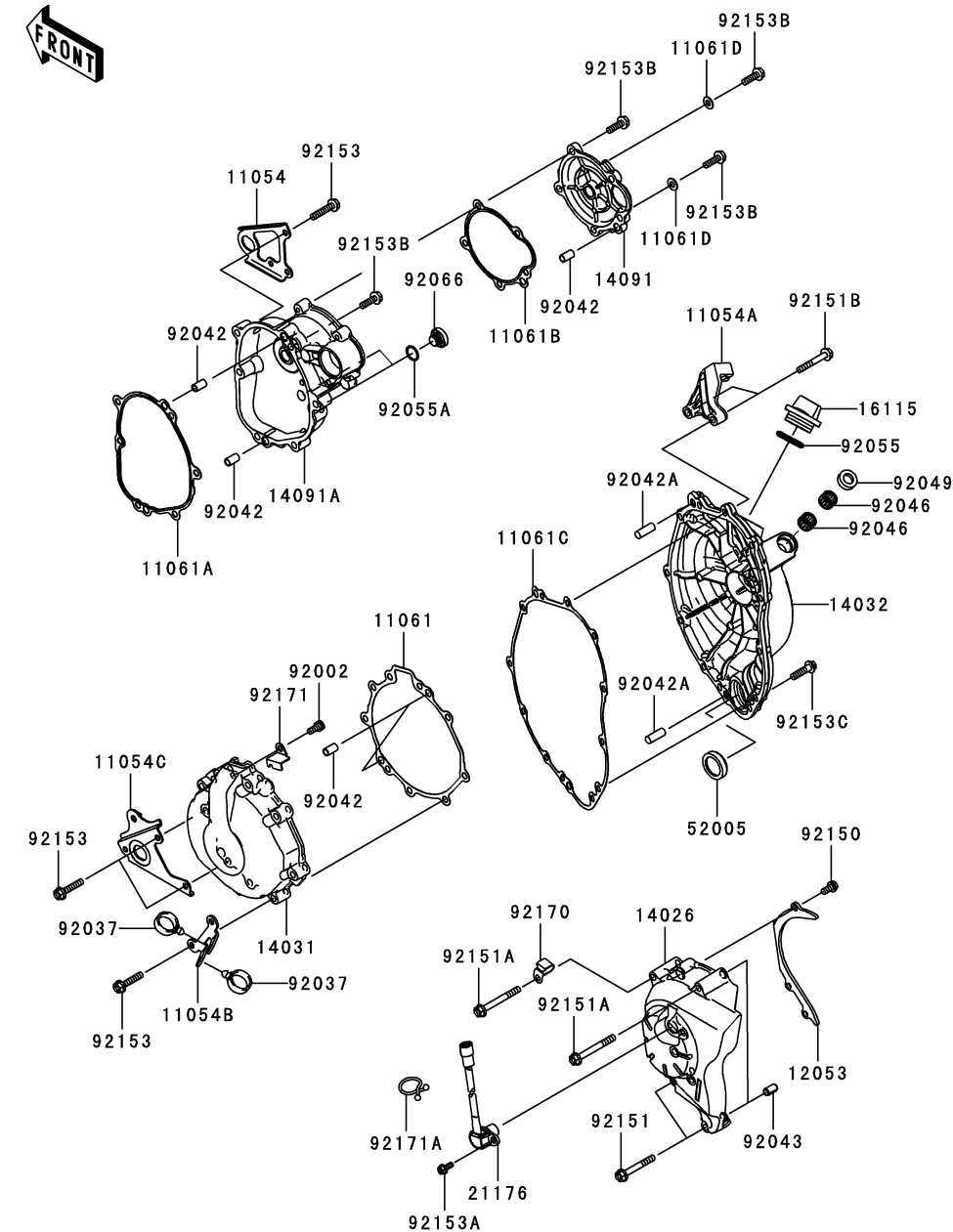

Ref. No.	Part No.	Description	Spec Code	Quantity-ZX600	
				'07	P7F
11054	11054-0579	BRACKET,RH COWL		1	
11054A	11054-1212	BRACKET,CLUTCH CABLE HOLDER		1	
11054B	11054-1643	BRACKET		1	
11054C	11054-1910	BRACKET,LH COWL		1	
11061	11061-0249	GASKET,GENERATOR COVER		1	
11061A	11061-0250	GASKET,LARGE COVER		1	
11061B	11061-0251	GASKET,SMALL COVER		1	
11061C	11061-0252	GASKET,CLUTCH COVER		1	
11061D	11061-0262	GASKET,6.2X13.5X1.0		2	
12053	12053-0109	GUIDE-CHAIN		1	
14026	14026-0040-11E	COVER-CHAIN,F.S.BLACK		1	
14031	14031-0082-11E	COVER-GENERATOR,F.S.BLACK		1	
14032	14032-0088-11E	COVER-CLUTCH,F.S.BLACK		1	
14091	14091-0620	COVER,STARTER SMALL		1	
14091A	14091-0802	COVER,STARTER LARGE		1	
16115	16115-1009	CAP-OIL FILLER		1	
21176	21176-0045	SENSOR,SPEED		1	
52005	52005-0024	GAUGE		1	
92002	92002-1796	BOLT,SOCKET,6X12		1	
92037	92037-1827	CLAMP,HOSE		2	
92042	92042-007	PIN,DOWEL,6.3X8X14		5	
92042A	92042-044	PIN,DOWEL,8X22		2	
92043	92043-1263	PIN,6.2X8X14		2	
92046	92046-1010	BEARING-NEEDLE,HK1210		2	
92049	92049-1475	SEAL-OIL,CLUTCH RELEASE		1	
92055	92055-049	RING-O,31.7X2.4		1	
92055A	92055-1141	RING-O,ID=13.8		2	
92066	92066-0067	PLUG,TIMING HOLE		2	
92150	92150-1841	BOLT,FLANGED-SMALL,6X12		3	
92151	92151-1521	BOLT,FLANGED,6X45		2	
92151A	92151-1540	BOLT,FLANGED,6X55		2	
92151B	92151-1583	BOLT,FLANGED,6X40		2	
92153	92153-1574	BOLT-FLANGED,6X30		14	
92153A	92153-1582	BOLT-FLANGED,5X12		1	
92153B	92153-1651	BOLT,FLANGED,6X20		6	
92153C	92153-1716	BOLT,FLANGED,6X25		10	
92170	92170-1577	CLAMP		1	
92171	92171-0938	CLAMP		1	
92171A	92171-1185	CLAMP		1	

This catalog covers:
'07 ZX600P7F Engine

GRID NO. **C-7** This grid covers:
Oil Pan

E1434

Ref. No.	Part No.	Description	Spec Code	Quantity-ZX600	
				'07	P7F
11061	11061-0253	GASKET,OIL PAN		1	
49034	49034-0019	PAN-OIL		1	
92043	92043-1263	PIN,6.2X8X14		2	
92065	92065-097	GASKET,12X22X2		1	
92066	92066-1174	PLUG,OIL DRAIN,12X15		1	
92153	92153-1569	BOLT-FLANGED,6X25		17	
92170	92170-1577	CLAMP		1	

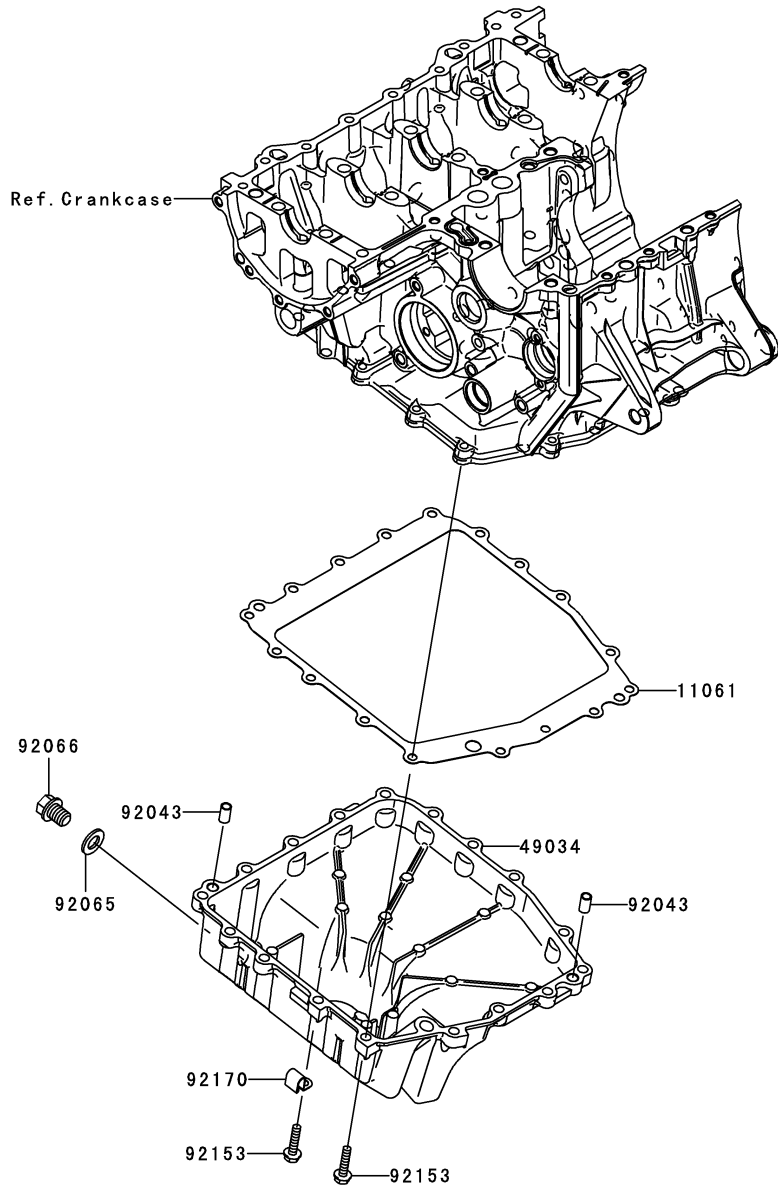

This catalog covers:
'07 ZX600P7F Engine

GRID NO. **C-8** This grid covers:
Throttle

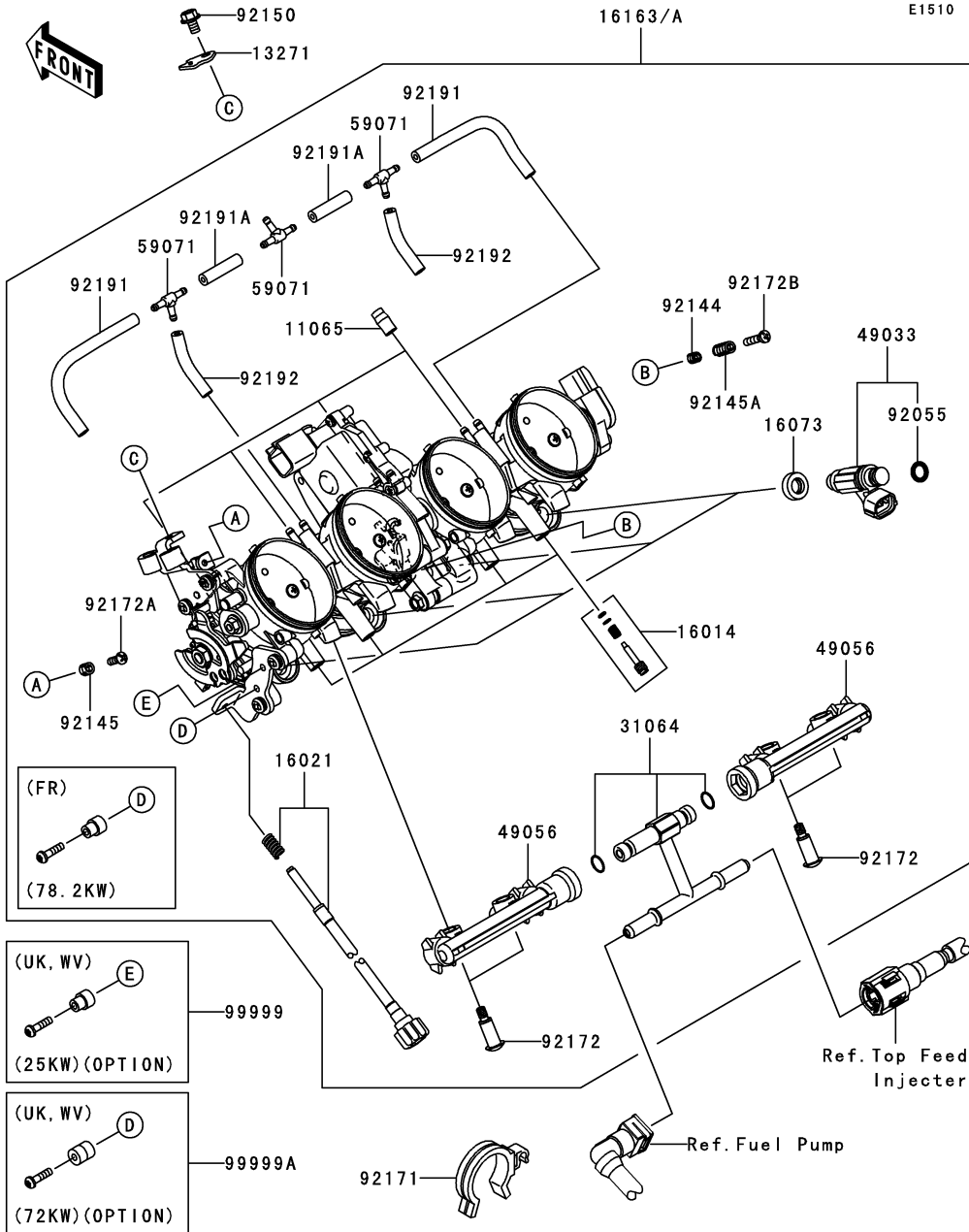

Ref. No.	Part No.	Description	Spec Code	Quantity-ZX600		
				'07	P7F	
11065	11065-0018	CAP	4			
13271	13271-0559	PLATE	1			
16014	16014-0002	SCREW-PILOT AIR	4			
16021	16021-0014	SCREW-THROTTLE STOP	1			
16073	16073-3707	INSULATOR	4			
16163	16163-0085	THROTTLE-ASSY,TTK38				
	L-----	UK,WV	1			
16163A	16163-0089	THROTTLE-ASSY,TTK38				
	L-----	FR	1			
31064	31064-0023	PIPE-COMP,FUEL	1			
49033	49033-0013	NOZZLE-INJECTION	4			
49056	49056-0014	PIPE-INJECTION	2			
59071	59071-3752	JOINT,3WAY,T	3			
92055	92055-1622	RING-O,INJECTION NOZZLE	4			
92144	92144-1451	SPRING	1			
92145	92145-0294	SPRING	1			
92145A	92145-0510	SPRING,THROTTLE SYNCRO	1			
92150	92150-1406	BOLT,5X8	1			
92171	92171-0359	CLAMP	1			
92172	92172-0064	SCREW,PIPE INJECTION	4			
92172A	92172-0129	SCREW	1			
92172B	92172-0309	SCREW,THROTTLE SYNCRO	1			
92191	92191-0023	TUBE,3X7X100	2			
92191A	92191-0025	TUBE,3X7X30	2			
92192	92192-0018	TUBE,3X7X95	2			
99999	99999-0088	KIT.,25KW				
	L-----	UK,WV	1			
	(OPTION)					
99999A	99999-0089	KIT.,72KW				
	L-----	UK,WV	1			
	(OPTION)					

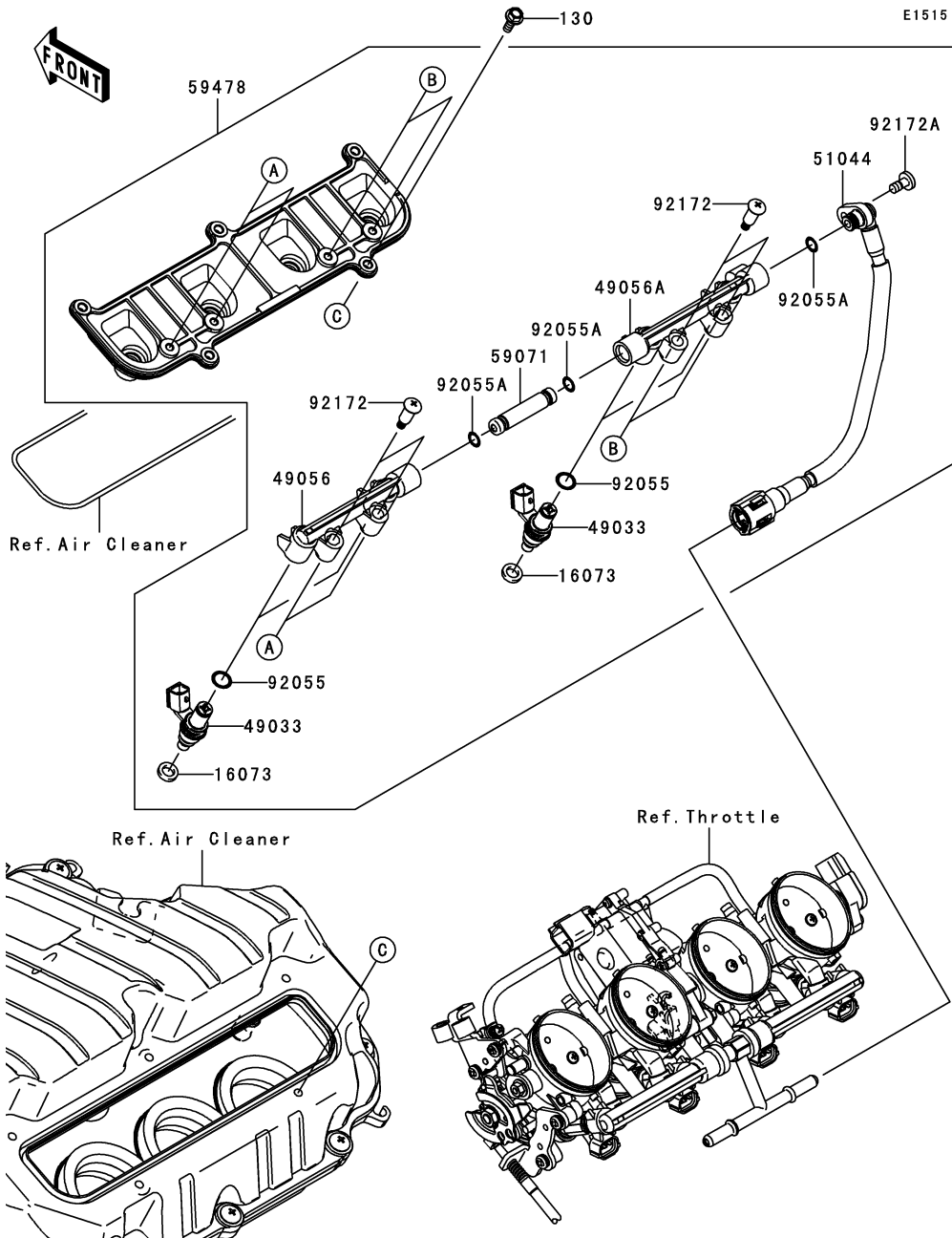

Ref. No.	Part No.	Description	Spec Code	Quantity-ZX600	
				'07	P7F
16073	16073-0010	INSULATOR		4	
49033	49033-0015	NOZZLE-INJECTION		4	
49056	49056-0015	PIPE-INJECTION		1	
49056A	49056-0016	PIPE-INJECTION		1	
51044	51044-0033	TUBE-ASSY,FUEL		1	
59071	59071-0034	JOINT		1	
59478	59478-0004	NOZZLE-ASSY, TOP INJECTOR		1	
92055	92055-0077	RING-O		4	
92055A	92055-0079	RING-O		3	
92172	92172-0064	SCREW, PIPE INJECTION		4	
92172A	92172-0272	SCREW, TORX		1	
130	130J0514	BOLT-FLANGED, 5X14		5	

This catalog covers:
'07 ZX600P7F Engine

GRID NO. **C-10** This grid covers:
Fuel Pump

E1520

Ref. No.	Part No.	Description	Spec Code	Quantity-ZX600			
				'07			
			P7F				

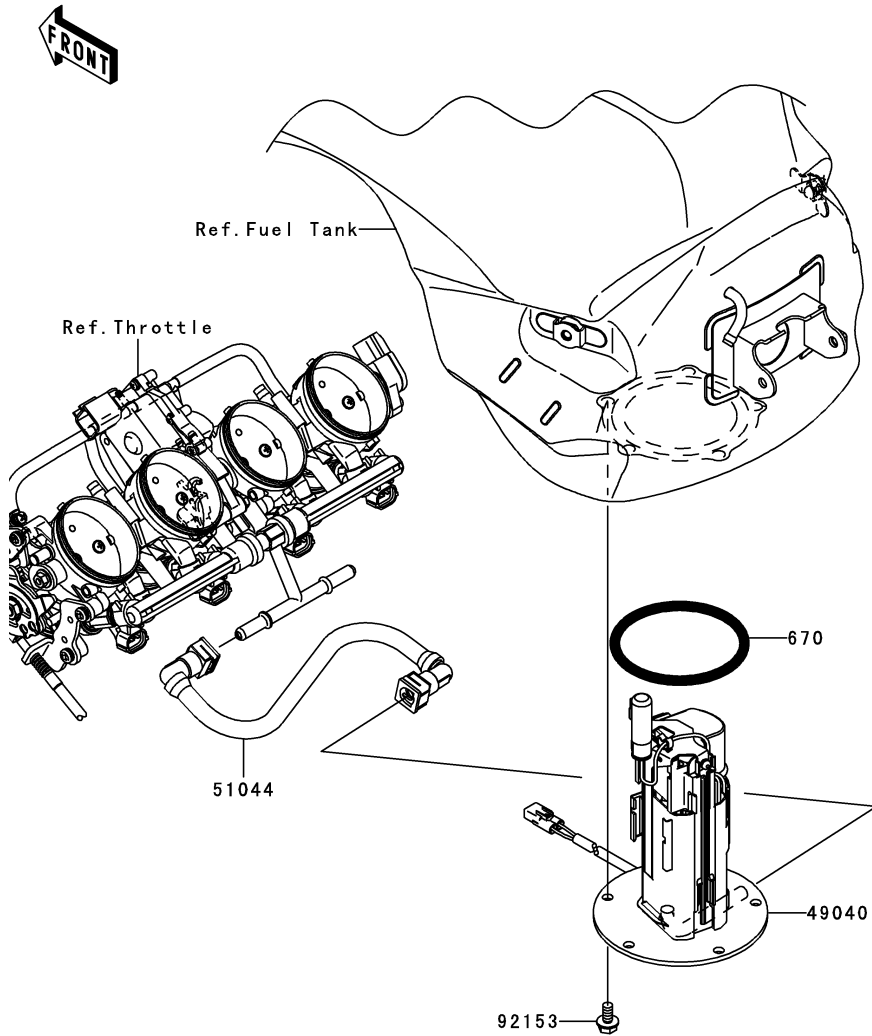

49040	49040-0023	PUMP-FUEL		1
51044	51044-0032	TUBE-ASSY,FUEL		1
92153	92153-1283	BOLT,FLANGED,6X12		5
670	670E5075	O RING		1

This catalog covers:
'07 ZX600P7F Engine

GRID NO. **C-11** This grid covers:
Fuel Injection

E1530

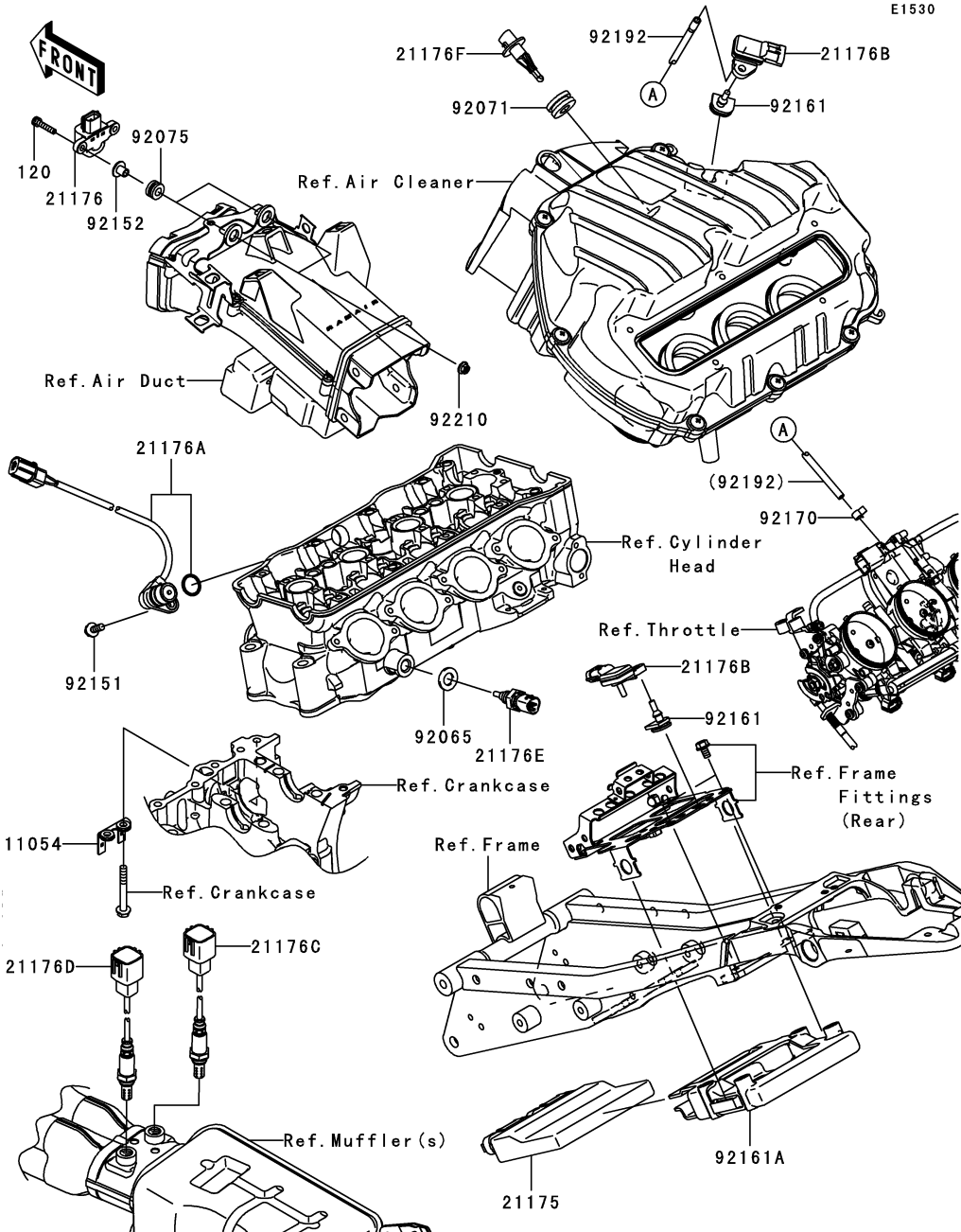

Ref. No.	Part No.	Description	Spec Code	Quantity-ZX600	
				'07	P7F
11054	11054-0817	BRACKET,OXYGEN SENSOR		1	
21175	21175-0109	CONTROL UNIT-ELECTRONIC		1	
21176	21176-0026	SENSOR,VEHICLE-DOWN		1	
21176A	21176-0034	SENSOR,CAM		1	
21176B	21176-0058	SENSOR,PRESSURE		2	
21176C	21176-0073	SENSOR,OXYGEN		1	
21176D	21176-0086	SENSOR,OXYGEN		1	
21176E	21176-1120	SENSOR,WATER TEMP		1	
21176F	21176-2106	SENSOR,AIR TEMP		1	
92065	92065-097	GASKET,12X22X2		1	
92071	92071-0033	GROMMET,10.9X25X11.6		1	
92075	92075-1912	DAMPER		2	
92151	92151-1774	BOLT,FLANGED,6X16		1	
92152	92152-0134	COLLAR		2	
92161	92161-0041	DAMPER		2	
92161A	92161-0381	DAMPER,ECU		1	
92170	92170-1128	CLAMP,HOSE		1	
92192	92192-0352	TUBE,L=300MM		1	
92210	92210-0007	NUT,FLANGED,5MM		2	
120	120W0522	BOLT-SOCKET,5X22		2	

This catalog covers:
'07 ZX600P7F Engine

GRID NO. This grid covers:
C-12 Oil Pump

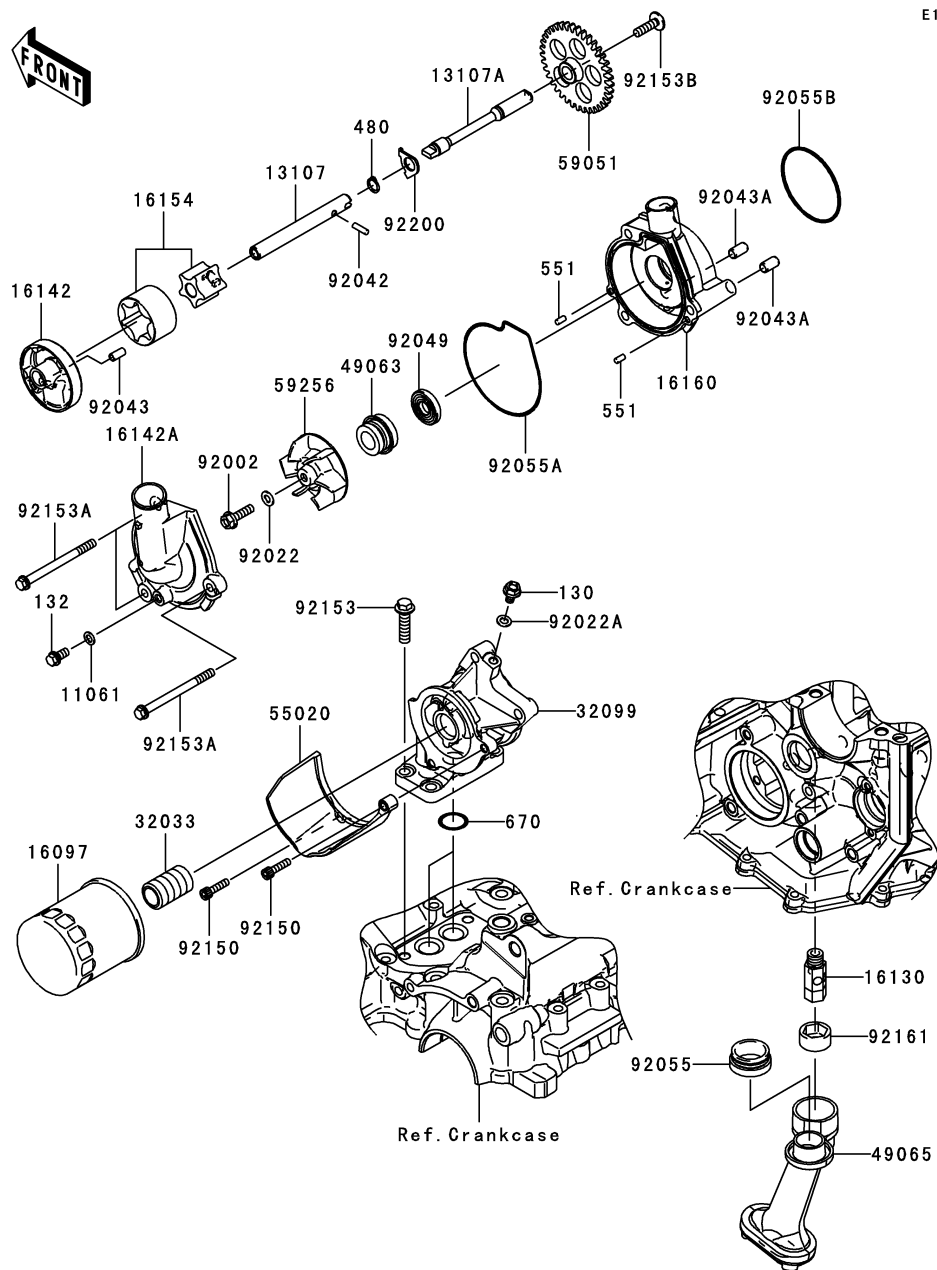

E1710

Ref. No.	Part No.	Description	Spec Code	Quantity-ZX600	
				'07	P7F
11061	11061-0107	GASKET		1	
13107	13107-0131	SHAFT,PUMP,LH		1	
13107A	13107-0132	SHAFT,PUMP,RH		1	
16097	16097-0004	FILTER-ASSY-OIL		1	
16130	16130-1059	VALVE-ASSY-RELIEF		1	
16142	16142-0041	COVER-PUMP,OIL		1	
16142A	16142-0050	COVER-PUMP,WATER		1	
16154	16154-0057	ROTOR-PUMP		1	
16160	16160-0140	BODY,WATER PUMP		1	
32033	32033-1535	PIPE,OIL FILTER		1	
32099	32099-0035	CASE,OIL FILTER&COOLER		1	
49063	49063-1055	SEAL-MECHANICAL,WATER		1	
49065	49065-0016	FILTER-OIL,INSIDE		1	
55020	55020-0358	GUARD,OIL FILTER		1	
59051	59051-0067	GEAR-SPUR,37T		1	
59256	59256-1074	IMPELLER		1	
92002	92002-1154	BOLT,6X22		1	
92022	92022-077	WASHER,6.1X12X1		1	
92022A	92022-304	WASHER,6.2X11X1		1	
92042	92042-030	PIN,DOWEL,4X13.8		1	
92043	92043-1262	PIN,4.2X6X12		1	
92043A	92043-1263	PIN,6.2X8X14		2	
92049	92049-1336	SEAL-OIL,SC 11 28.55 5		1	
92055	92055-1503	RING-O,OIL FILTER		1	
92055A	92055-1532	RING-O,WATER PUMP COVER		1	
92055B	92055-3018	RING-O,59.6X2.4		1	
92150	92150-1019	BOLT,SOCKET,5X20		2	
92153	92153-1086	BOLT,FLANGED,8X30		4	
92153A	92153-1649	BOLT,FLANGED,6X75		3	
92153B	92153-1792	BOLT,SOCKET,6X22		1	
92161	92161-0070	DAMPER		1	
92200	92200-0317	WASHER		1	
130	130Y0610	BOLT-FLANGED,6X10		1	
132	132L0612	BOLT-FLANGED-SMALL,6X12		1	
480	480J1100	CIRCLIP-TYPE-C,11MM		1	
551	551A0408	PIN-DOWEL,4X8		2	
670	670D2018	O RING		2	

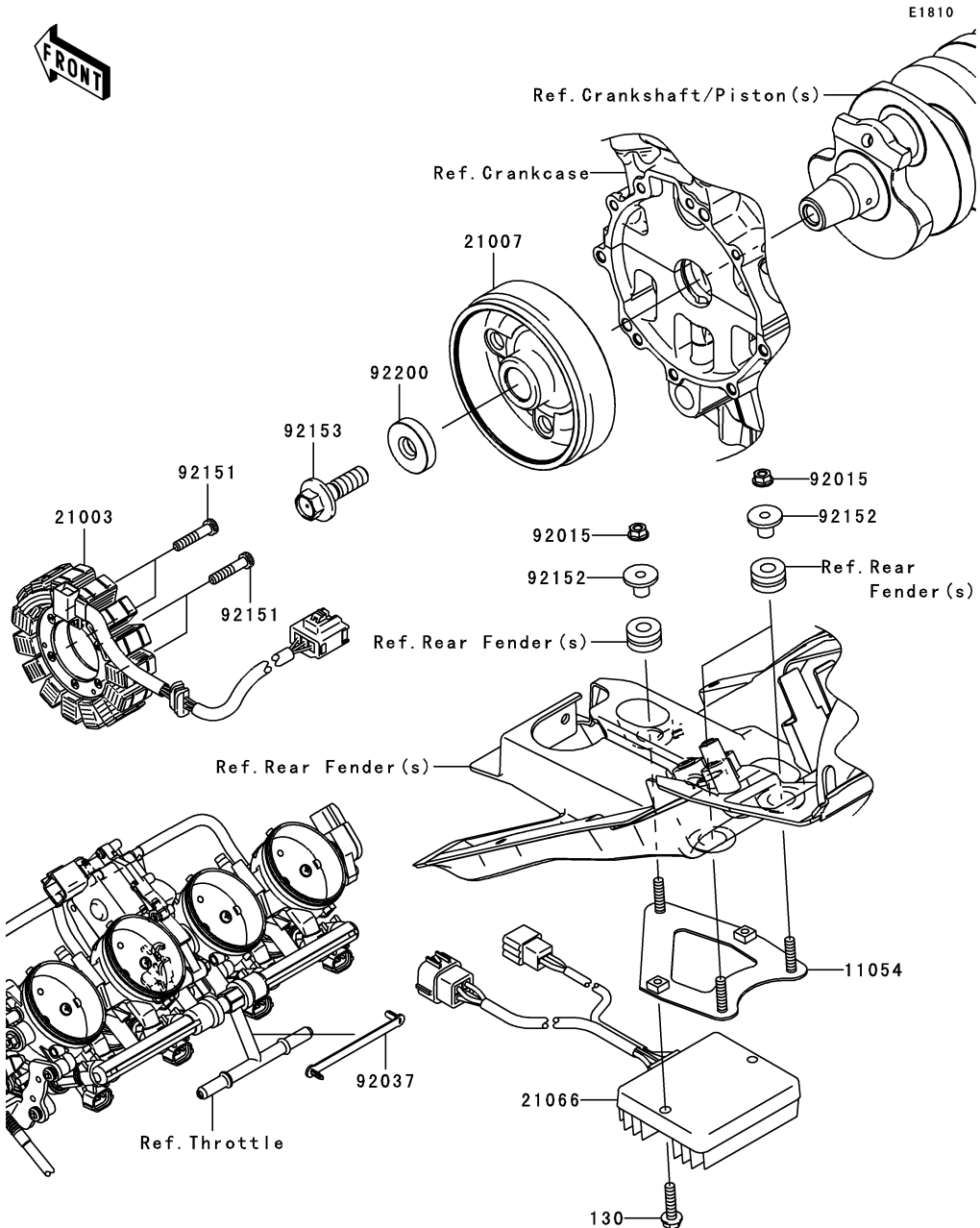

Ref. No.	Part No.	Description	Spec Code	Quantity-ZX600		
				'07		
11054	11054-0761	BRACKET,REGULATOR			1	
21003	21003-0049	STATOR			1	
21007	21007-0091	ROTOR			1	
21066	21066-0025	REGULATOR-VOLTAGE			1	
92015	92015-1193	NUT,FLANGED,6MM			3	
92037	92037-1903	CLAMP,SPEED,L=80.5			1	
92151	92151-1626	BOLT,6X30			4	
92152	92152-0091	COLLAR			3	
92153	92153-1855	BOLT,12X40			1	
92200	92200-1249	WASHER,12X36X8			1	
130	130L0625	BOLT-FLANGED,6X25			2	

E1830

Ref. No.	Part No.	Description	Spec Code	Quantity-ZX600			
				'07			
21171	21171-1282	COIL-ASSY-IGNITION				4	
59026	59026-0026	COIL-PULSING				1	
92070	92070-1266	PLUG-SPARK,CR9E(NGK)				4	
130	130L0512	BOLT-FLANGED,5X12				2	

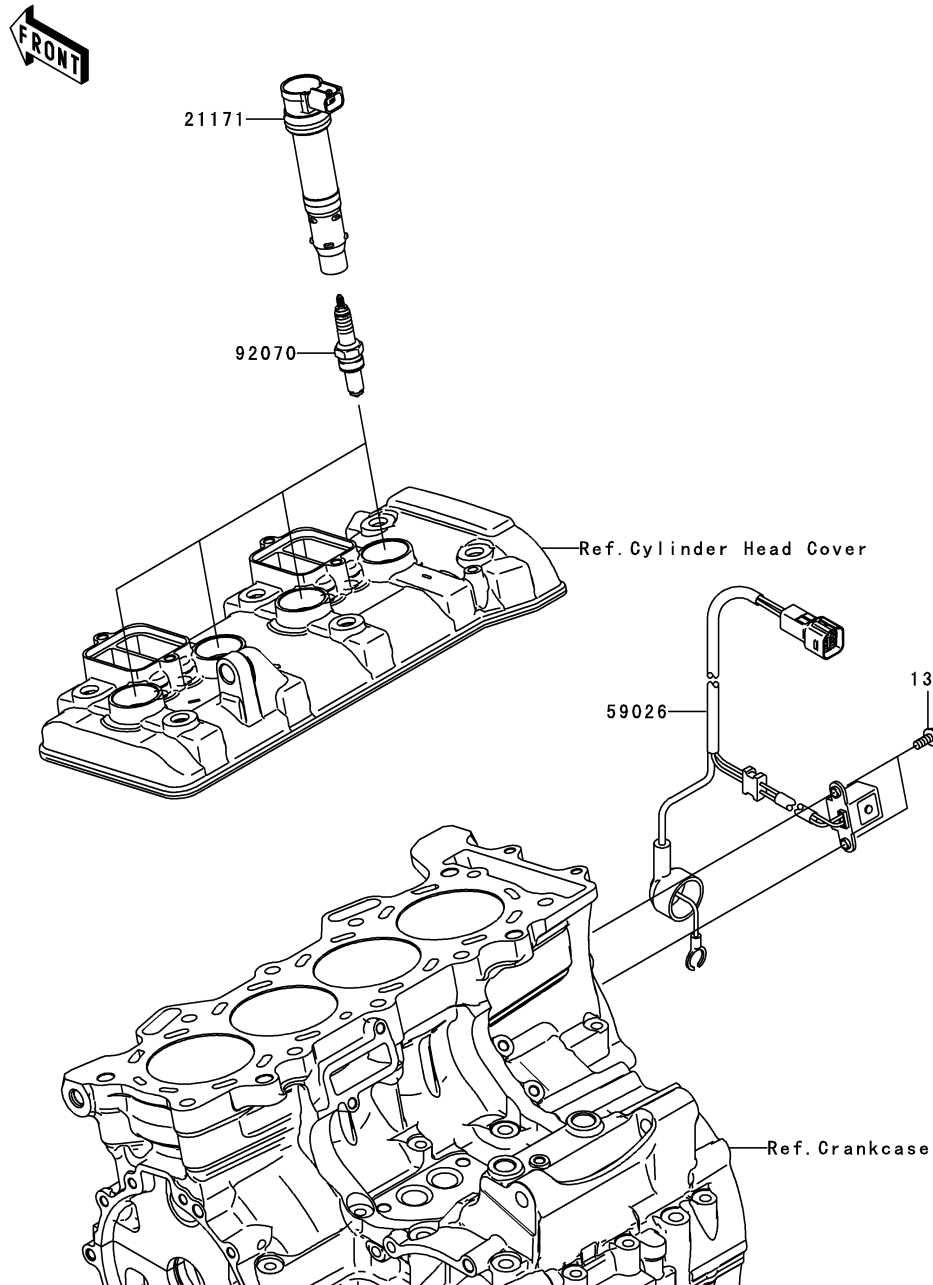

This catalog covers:
'07 ZX600P7F Engine

GRID NO. **D-3** This grid covers:
Starter Motor

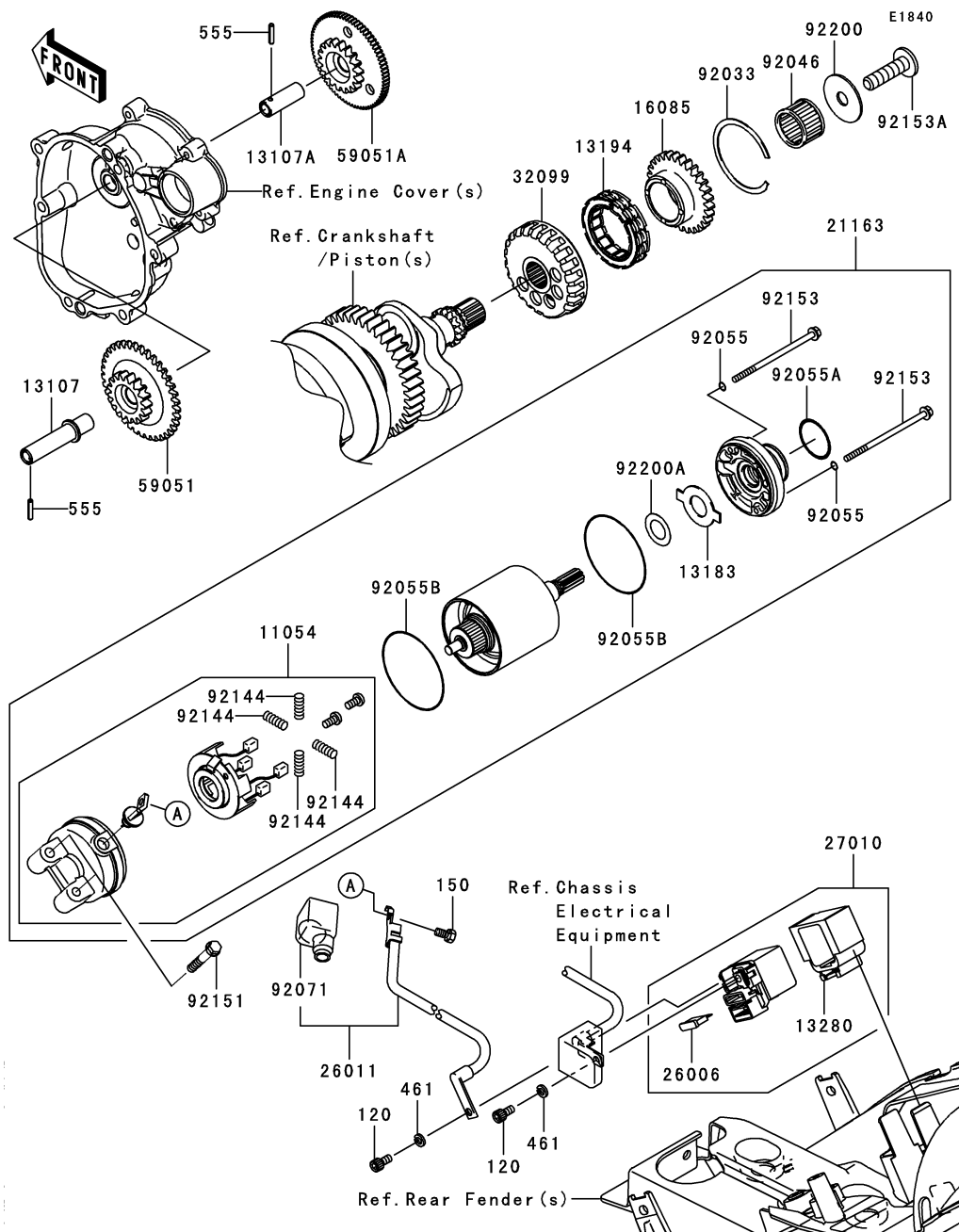

Ref. No.	Part No.	Description	Spec Code	Quantity-ZX600	
				'07	P7F
11054	11054-1175	BRACKET		1	
13107	13107-0168	SHAFT,ONEWAY CLUTCH SIDE		1	
13107A	13107-0174	SHAFT,STARTER SIDE		1	
13183	13183-1460	PLATE		1	
13194	13194-3705	CLUTCH-ONEWAY		1	
13280	13280-0109	HOLDER,SWITCH		1	
16085	16085-0101	GEAR,29T		1	
21163	21163-0041	STARTER-ELECTRIC		1	
26006	26006-1006	FUSE,30A-G		1	
26011	26011-0118	WIRE-LEAD		1	
27010	27010-0030	SWITCH,MAGNETIC		1	
32099	32099-0026	CASE,STARTER CLUTCH		1	
59051	59051-0068	GEAR-SPUR,ONEWAY CLUTCH SIDE		1	
59051A	59051-0069	GEAR-SPUR,STARTER SIDE		1	
92033	92033-3731	RING-SNAP		1	
92046	92046-0004	BEARING-NEEDLE,RS263020		1	
92055	92055-0013	RING-O,STARTER		2	
92055A	92055-0126	RING-O		1	
92055B	92055-1455	RING-O		2	
92071	92071-0031	GROMMET		1	
92144	92144-1423	SPRING,BRUSH		4	
92151	92151-1874	BOLT,6X35		2	
92153	92153-0405	BOLT		2	
92153A	92153-1521	BOLT,TORX,10X38		1	
92200	92200-0238	WASHER,10.5X37X1.6		1	
92200A	92200-1019	WASHER		1	
120	120S0510	BOLT-SOCKET,5X10		2	
150	150R0510	BOLT-WS,5X10		1	
461	461K0500	WASHER-SPRING,5MM,BLACK		2	
555	555A0316	PIN-SPRING,3X16		2	

This catalog covers:
'07 ZX600P7F Engine

GRID NO. This grid covers:
D-4 Radiator

E3032

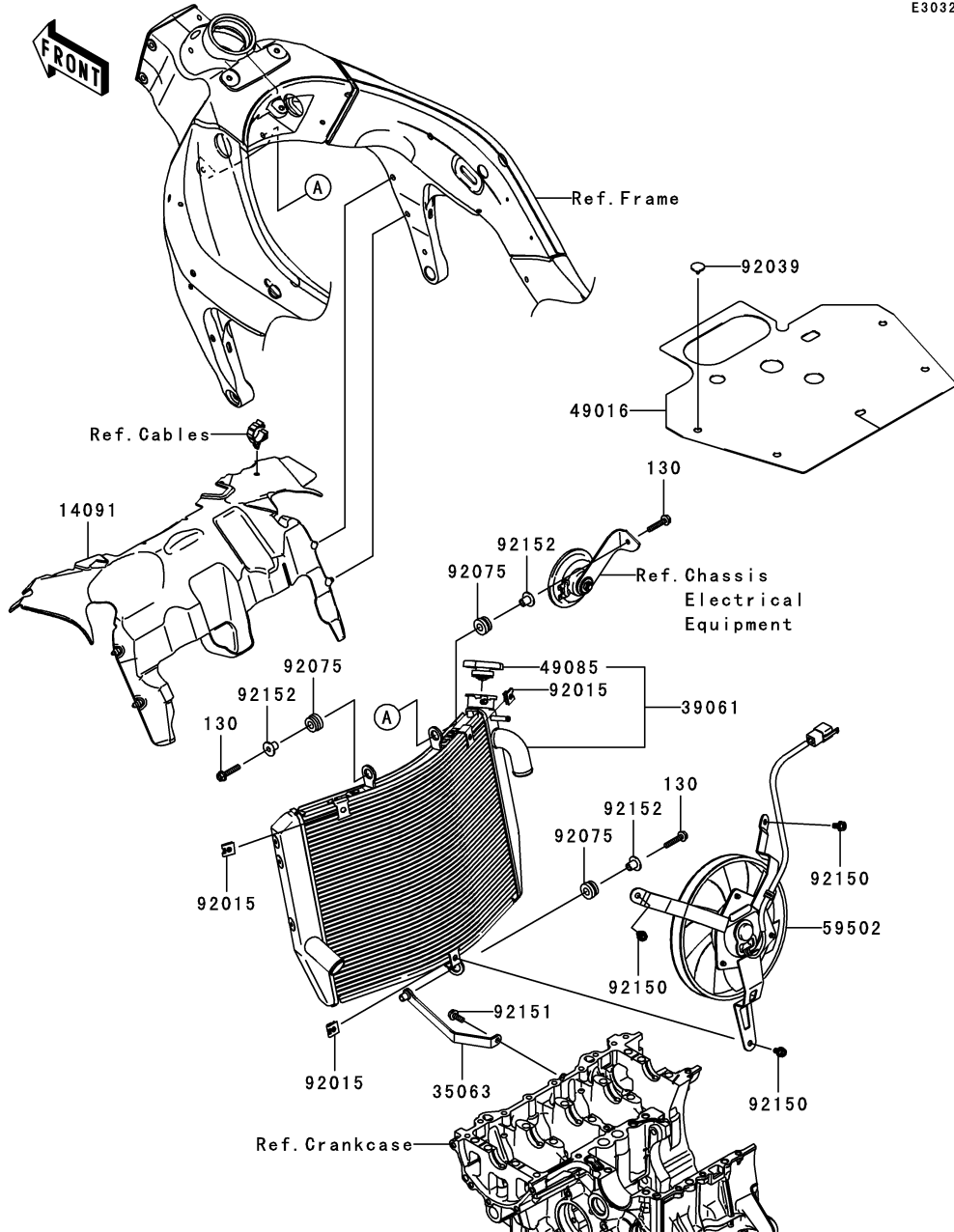

Ref. No.	Part No.	Description	Spec Code	Quantity-ZX600	
				'07	P7F
14091	14091-0799	COVER,HOT WIND		1	
35063	35063-0329	STAY,RADIATOR BOTTOM		1	
39061	39061-0092	RADIATOR-ASSY		1	
49016	49016-0042	COVER-SEAL		1	
49085	49085-1066	CAP-ASSY-PRESSURE		1	
59502	59502-0027	FAN-ASSY		1	
92015	92015-1487	NUT		3	
92039	92039-0065	RIVET		1	
92075	92075-1123	DAMPER,RUBBER		3	
92150	92150-1186	BOLT,6X12		3	
92151	92151-1774	BOLT,FLANGED,6X16		1	
92152	92152-1074	COLLAR		3	
130	130W0630	BOLT-FLANGED,6X30		3	

This catalog covers:
'07 ZX600P7F Engine

GRID NO. **D-5** This grid covers:
Oil Cooler

E3034

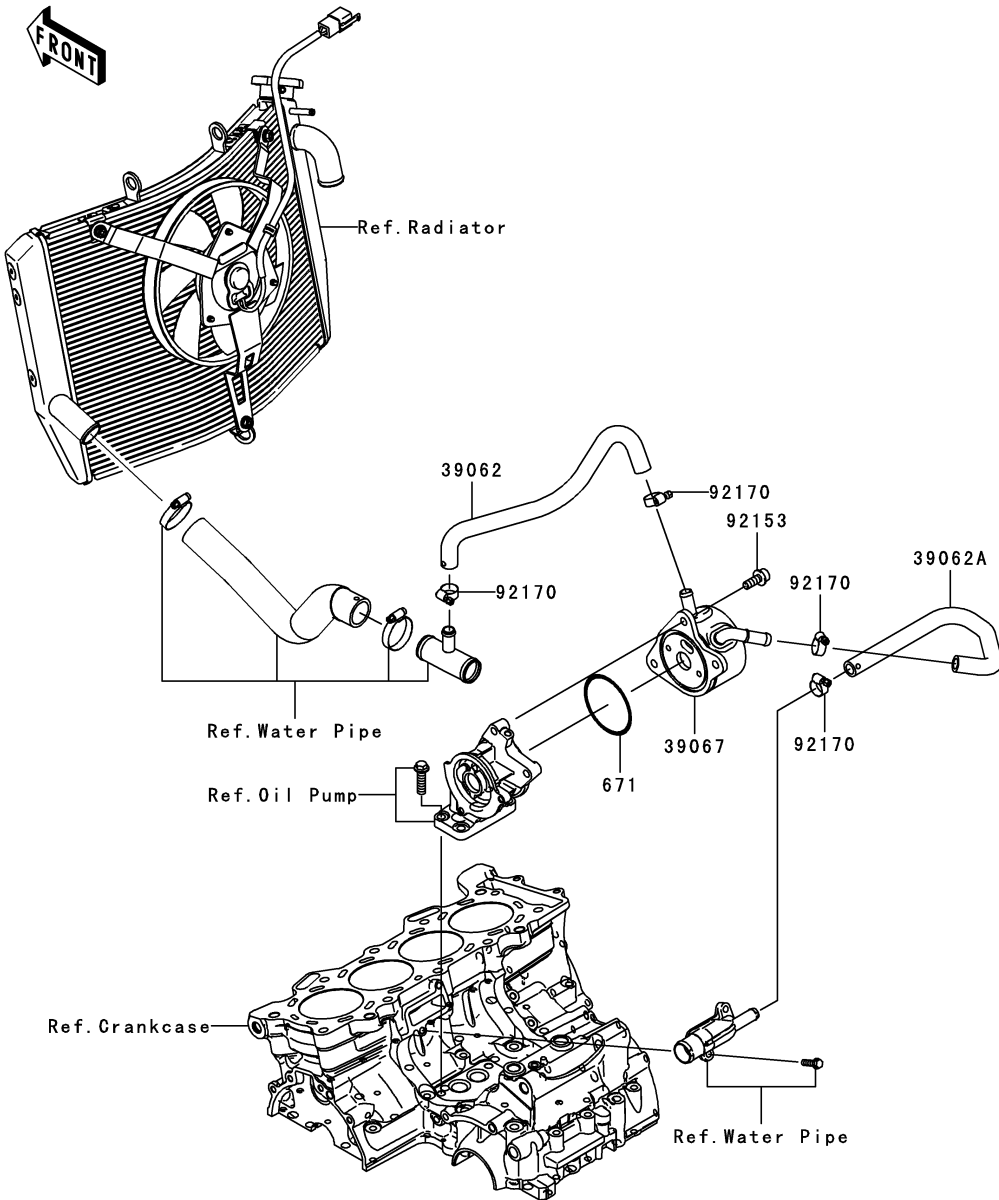

Ref. No.	Part No.	Description	Spec Code	Quantity-ZX600			
				'07			
39062	39062-0197	HOSE-COOLING,O.COOLER-W.PUMP					1
39062A	39062-0198	HOSE-COOLING,CYLINDER-O.COOLER					1
39067	39067-0014	COOLER-OIL					1
92153	92153-1650	BOLT,SOCKET,8X22					3
92170	92170-3729	CLAMP					4
671	671B2565	O RING,65MM					1

This catalog covers:

'07 ZX600P7F Chassis

GRID NO.

E-3

This grid covers:

Frame

F2120

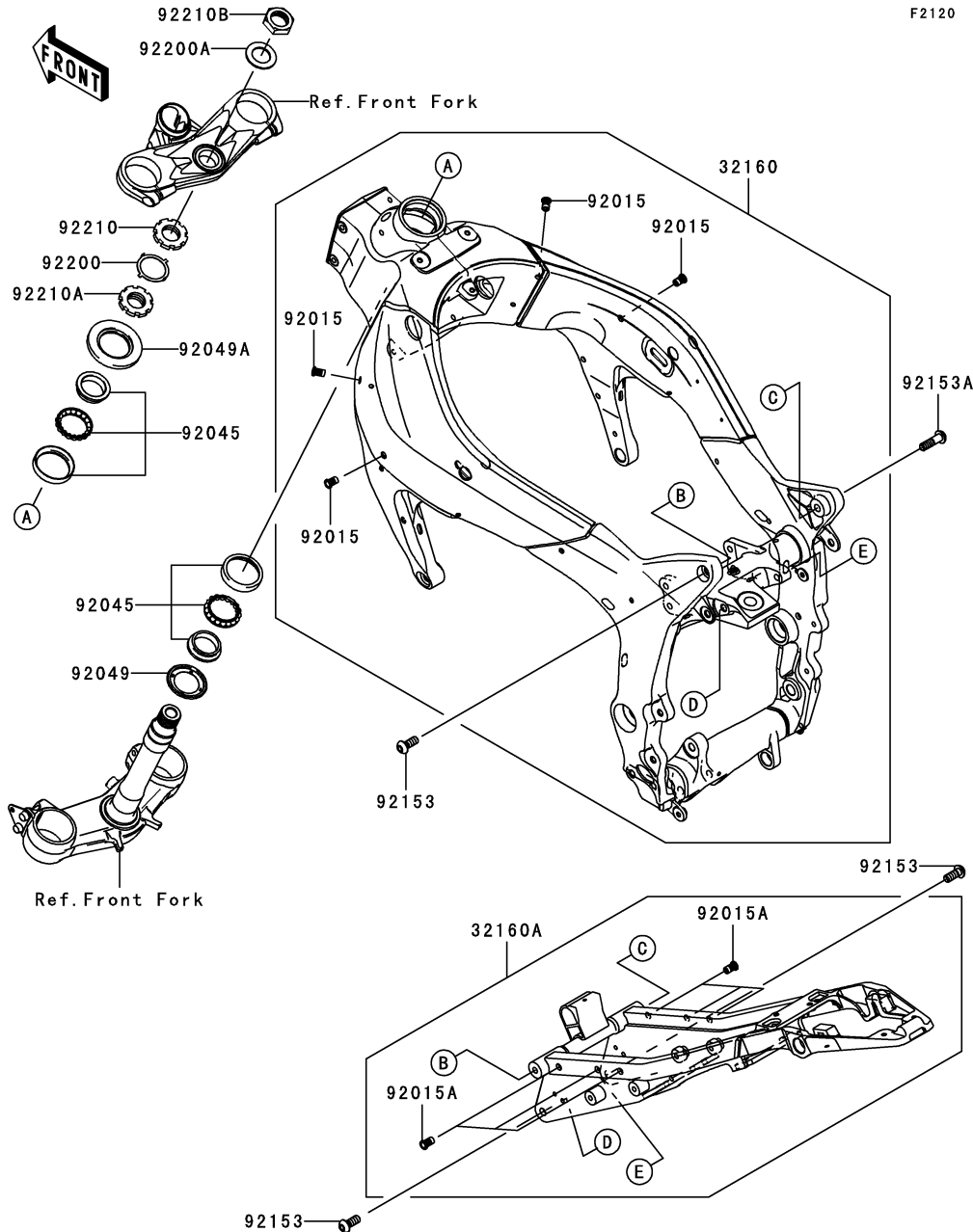

Ref. No.	Part No.	Description	Spec Code	Quantity-ZX600		
				'07		
				P7F		
32160	32160-0250-18R	FRAME-COMP,FR,BLACK				1
32160A	32160-0258	FRAME-COMP,RR				1
92015	92015-1791	NUT,POP,6MM,L=15				4
92015A	92015-1792	NUT,POP,6MM,L=16.5				6
92045	92045-1384	BEARING-BALL,SF07A17PX1V1				2
92049	92049-0022	SEAL-OIL,DS35X55X4				1
92049A	92049-1382	SEAL-OIL,XXH 43 75 6.4J				1
92153	92153-1136	BOLT,SOCKET,10X25				3
92153A	92153-1812	BOLT,SOCKET,10X45				1
92200	92200-0036	WASHER				1
92200A	92200-0209	WASHER,28.5X42X1.6				1
92210	92210-0095	NUT,35MM				1
92210A	92210-0096	NUT,35MM				1
92210B	92210-0209	NUT,28MM				1

This catalog covers:
'07 ZX600P7F Chassis

GRID NO.

E-4

This grid covers:
Engine Mount

F2122

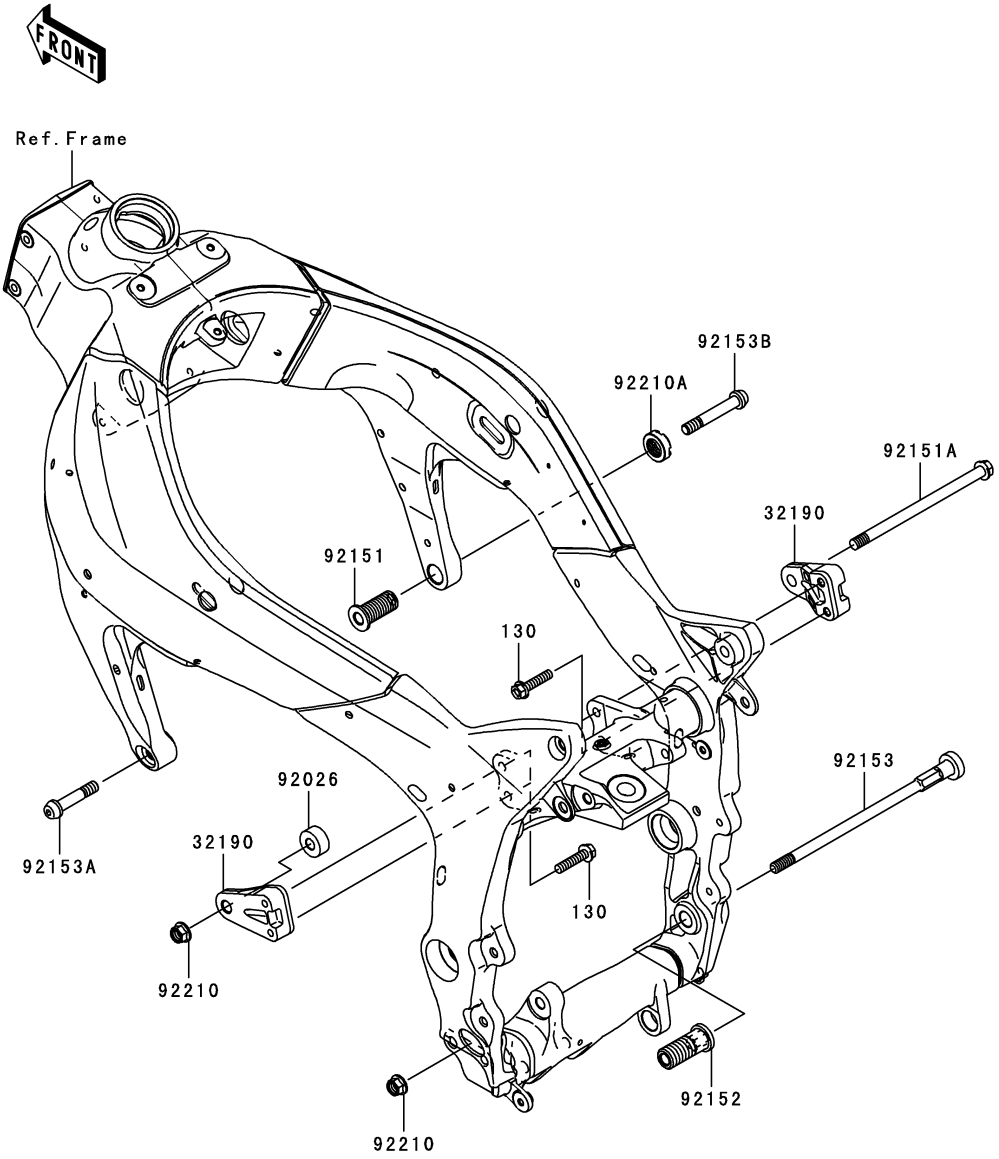

Ref. No.	Part No.	Description	Spec Code	Quantity-ZX600		
				'07		
32190	32190-0327	BRACKET-ENGINE,RR,UPP				2
92026	92026-0108	SPACER,10.5X26X11.5				1
92151	92151-1609	BOLT,ENGINE MOUNT,18MM				1
92151A	92151-1915	BOLT,FLANGED,10X190				1
92152	92152-0076	COLLAR,ENGINE MOUNT				1
92153	92153-0799	BOLT,SOCKET,10X227				1
92153A	92153-1690	BOLT,SOCKET,10X40				1
92153B	92153-1691	BOLT,SOCKET,10X65				1
92210	92210-1139	NUT,LOCK,FLANGED,10MM				2
92210A	92210-1390	NUT,CASTLE,18MM				1
130	130BA0835	BOLT-FLANGED,8X35				4

This catalog covers:
'07 ZX600P7F Chassis

GRID NO.

E-5

This grid covers:
Frame Fittings(Front)

F2130

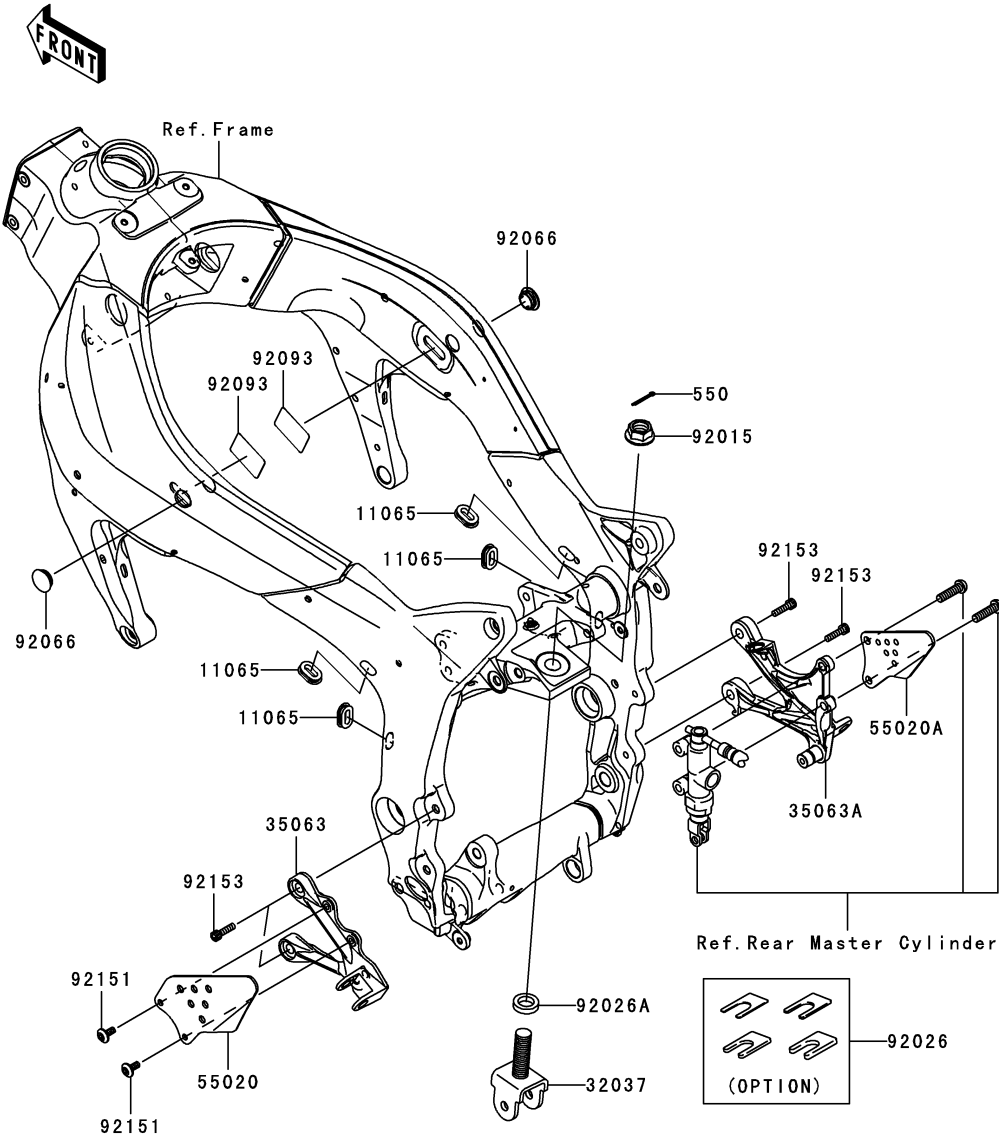

Ref. No.	Part No.	Description	Spec Code	Quantity-ZX600			
				'07			
11065	11065-0095	CAP				4	
32037	32037-1887	BRACKET-SHOCKABSORBER				1	
35063	35063-0160-W9	STAY,FR,LH,F.BLACK				1	
35063A	35063-0419-W9	STAY,FR,RH,F.BLACK				1	
55020	55020-0134	GUARD,FRONT STEP,LH				1	
55020A	55020-0268	GUARD,FRONT STEP,RH				1	
92015	92015-1881	NUT,FLANGED,16MM				1	
92026	92026-1586	SPACER,SET				1	
	(OPTION)						
92026A	92026-1594	SPACER,16.5X26X6				1	
92066	92066-0096	PLUG				2	
92093	92093-0034	SEAL				2	
92151	92151-1654	BOLT,SOCKET,6X14				2	
92153	92153-1621	BOLT,SOCKET,8X20				4	
550	550S3025	PIN-COTTER,3X25				1	

This catalog covers:
'07 ZX600P7F Chassis

GRID NO.

E-7

This grid covers:
Swingarm

F2141

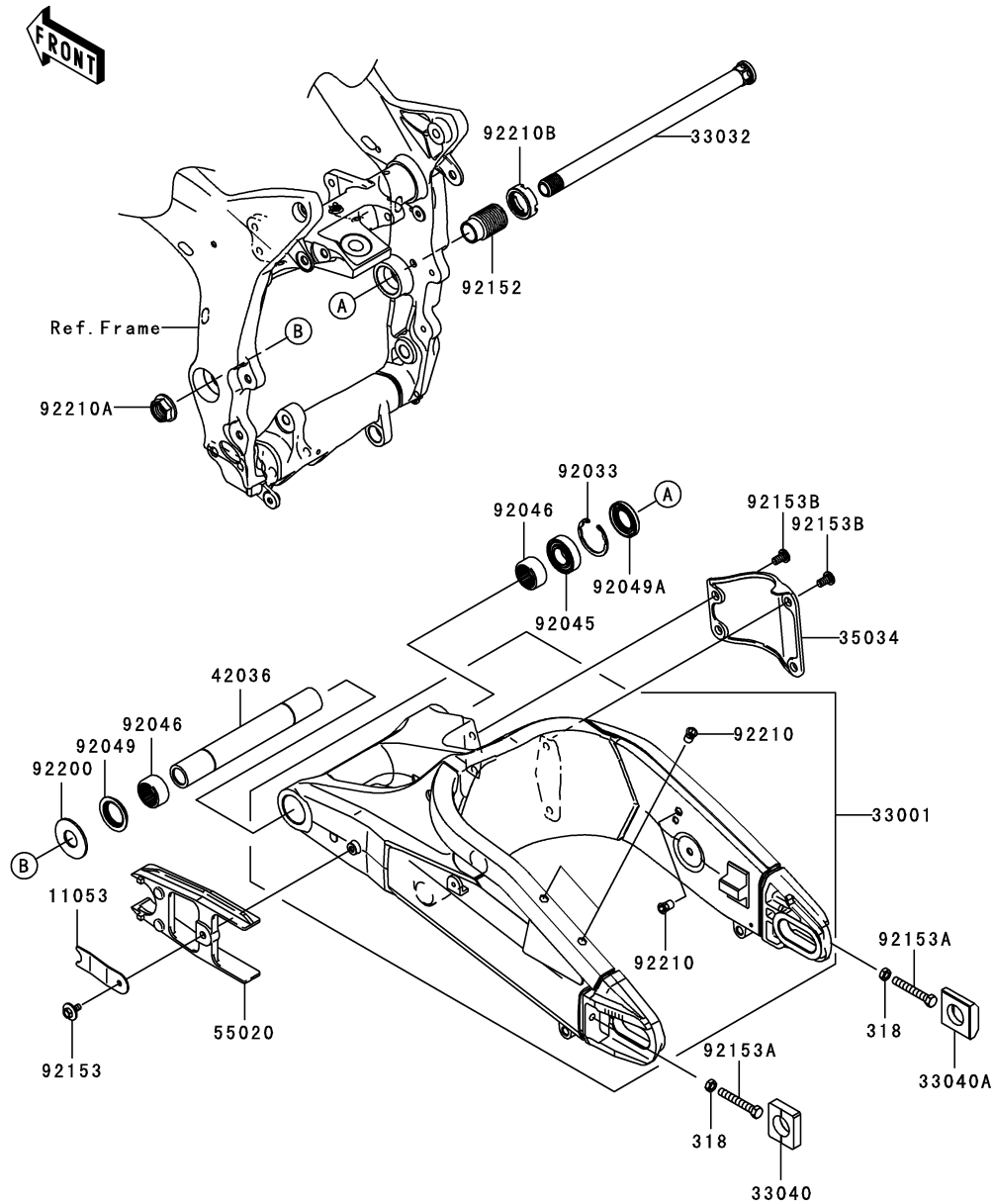

Ref. No.	Part No.	Description	Spec Code	Quantity-ZX600		
				'07		
				P7F		
11053	11053-1691	BRACKET,CHAIN GUARD				1
33001	33001-0126-18R	ARM-COMP-SWING,BLACK				1
33032	33032-0010	SHAFT-SWING ARM				1
33040	33040-1114	ADJUSTER-CHAIN				1
33040A	33040-1180	ADJUSTER-CHAIN,RH				1
35034	35034-0053-18R	REINFORCE,MUFFLER GUARD,BLACK				1
42036	42036-1283	SLEEVE,SWING ARM,L=213				1
55020	55020-0111	GUARD,CHAIN				1
92033	92033-1041	RING-SNAP,42MM				1
92045	92045-0017	BEARING-BALL,6004UL11				1
92046	92046-0008	BEARING-NEEDLE,7E-HVS 28X34X17				2
92049	92049-1181	SEAL-OIL				1
92049A	92049-1314	SEAL-OIL,MHSA25 42 6				1
92152	92152-0154	COLLAR,SWING ARM,L=47				1
92153	92153-1003	BOLT,6X16				1
92153A	92153-1407	BOLT,8X55				2
92153B	92153-1548	BOLT,SOCKET,8X15				4
92200	92200-1167	WASHER,20.3X48X2.3				1
92210	92210-0099	NUT,6MM				3
92210A	92210-0106	NUT,FLANGED,20MM				1
92210B	92210-0134	NUT,30MM				1
318	318G0800	NUT-HEX-SMALL,8MM				2

This catalog covers:
'07 ZX600P7F Chassis

GRID NO.

E-8

This grid covers:
Suspension

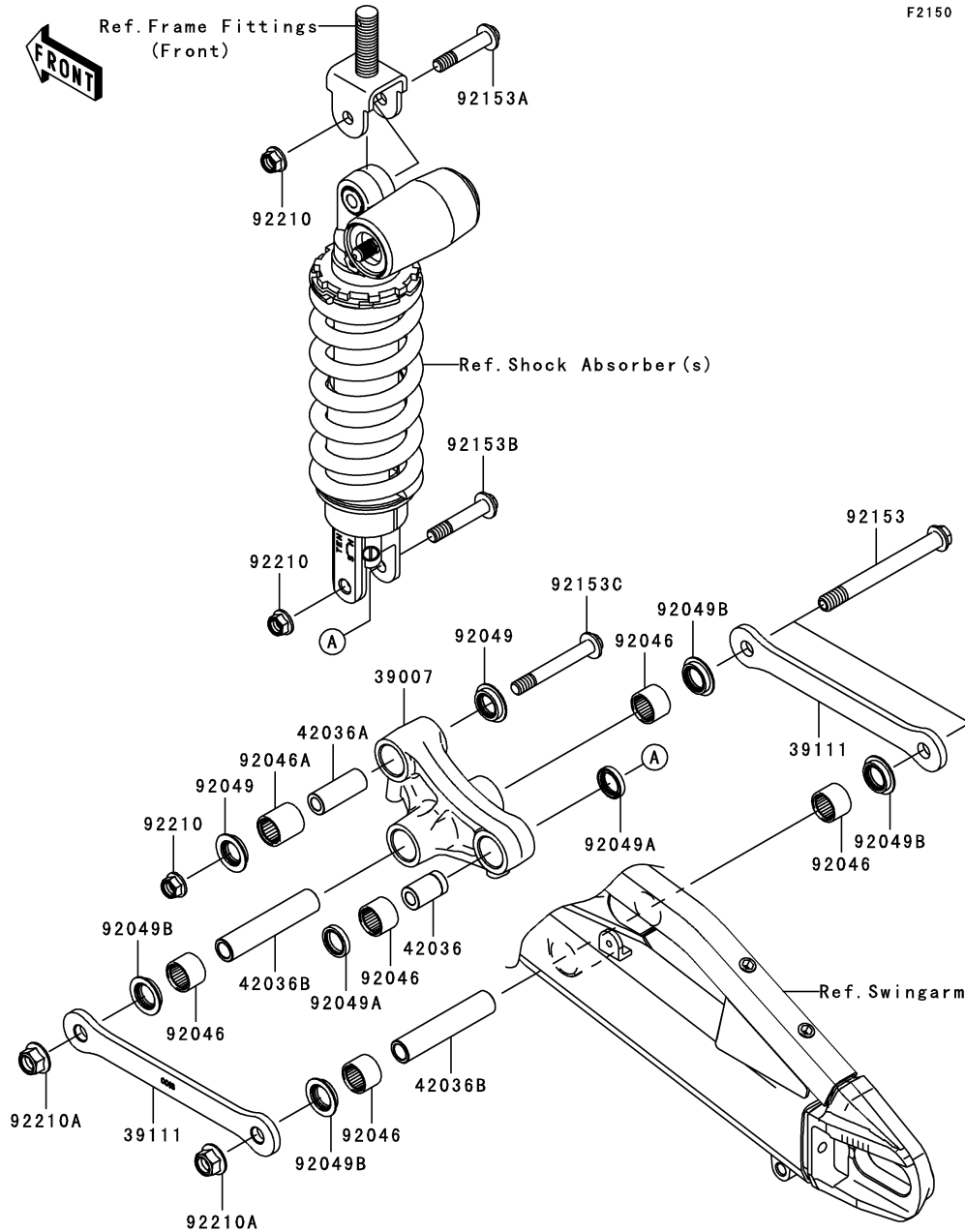

F2150

Ref. No.	Part No.	Description	Spec Code	Quantity-ZX600		
				'07	P7F	
39007	39007-0006	ARM-SUSP,UNI TRAK			1	
39111	39111-0018	ROD-TIE,SUSPENSION			2	
42036	42036-1258	SLEEVE,10.1X18X30			1	
42036A	42036-1342	SLEEVE,10.1X17X44.5			1	
42036B	42036-1360	SLEEVE,12.1X18X90			2	
92046	92046-1272	BEARING-NEEDLE,SFYZM182417			5	
92046A	92046-1273	BEARING-NEEDLE,SFYZM172425			1	
92049	92049-1223	SEAL-OIL,MHA17245.7F			2	
92049A	92049-1225	SEAL-OIL,MHA18244			2	
92049B	92049-1493	SEAL-OIL,KCR MF018N1			4	
92153	92153-0508	BOLT,FLANGED,12X117			2	
92153A	92153-1545	BOLT,FLANGED,10X51			1	
92153B	92153-1546	BOLT,FLANGED,10X55			1	
92153C	92153-1547	BOLT,FLANGED,10X77			1	
92210	92210-1139	NUT,LOCK,FLANGED,10MM			3	
92210A	92210-1150	NUT,LOCK,FLANGED,12MM			2	

This catalog covers:

'07 ZX600P7F Chassis

GRID NO.

E-9

This grid covers:

Footrests

F2160

Ref. No.	Part No.	Description	Spec Code	Quantity-ZX600			
				'07			
32085	32085-0047	STOPPER,REAR STEP				2	
34028	34028-0029	STEP,FR,LH				1	
34028A	34028-0030	STEP,FR,RH				1	
34028B	34028-1480	STEP,RR,LH				1	
34028C	34028-1481	STEP,RR,RH				1	
92043	92043-0028	PIN,12X36.5				2	
92043A	92043-1595	PIN,6X40				2	
92145	92145-0376	SPRING,STEP RETURN				2	
92145A	92145-1319	SPRING				2	
92153	92153-0303	BOLT,BANK SENSOR				2	
92200	92200-0043	WASHER,16X26X2.3				2	
482	482L0100	CIRCLIP-TYPE-E,10MM				2	
482A	482L5000	CIRCLIP-TYPE-E,5MM				2	
600	600A0800	BALL-STEEL,1/4"				2	

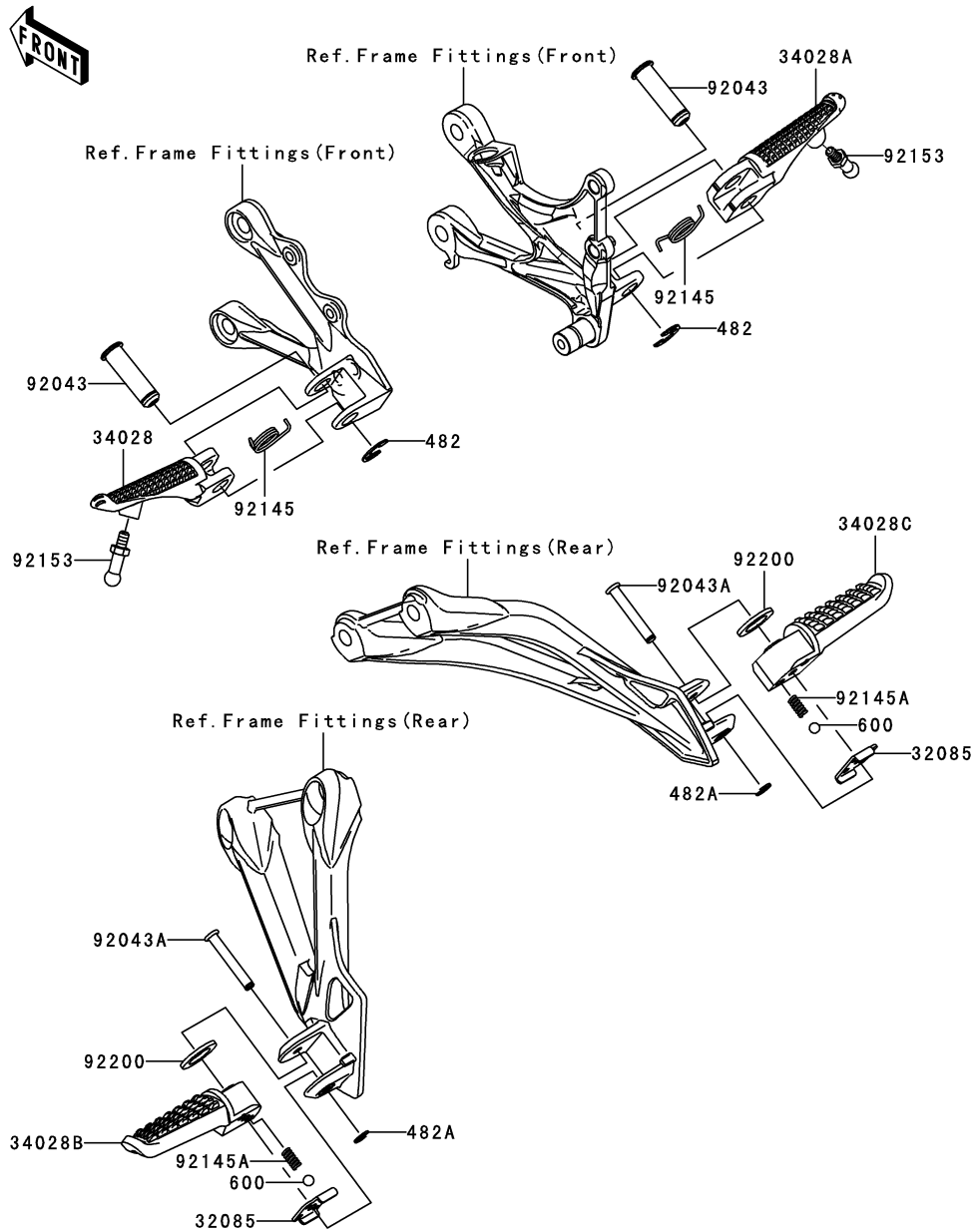

This catalog covers:

'07 ZX600P7F Chassis

GRID NO.

E-10

This grid covers:

Front Fender(s)

F2171

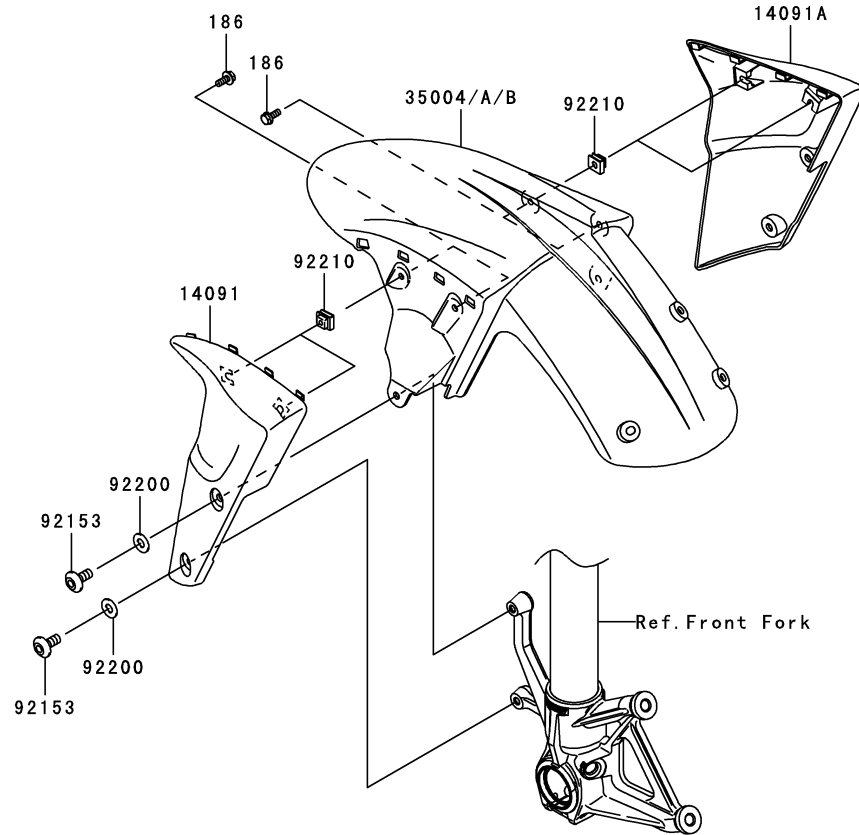

Ref. No.	Part No.	Description	Spec Code	Quantity-ZX600		
				'07		
14091	14091-0103-6Z	COVER,FRONT FENDER,LH,F.BLACK				1
14091A	14091-0104-6Z	COVER,FRONT FENDER,RH,F.BLACK				1
35004	35004-0076-H8	FENDER-FRONT,EBONY				1
35004A	35004-0076-17H	FENDER-FRONT,P.ORANGE				1
35004B	35004-0076-777	FENDER-FRONT,L.GREEN				1
92153	92153-1612	BOLT,SOCKET,6X14				4
92200	92200-1388	WASHER,6.5X14X1				4
92210	92210-1266	NUT,5MM				4
186	186L0514	BOLT-UPSET-WP,5X14				4

This catalog covers:

'07 ZX600P7F Chassis

GRID NO.

E-11

This grid covers:

Rear Fender(s)

F2172

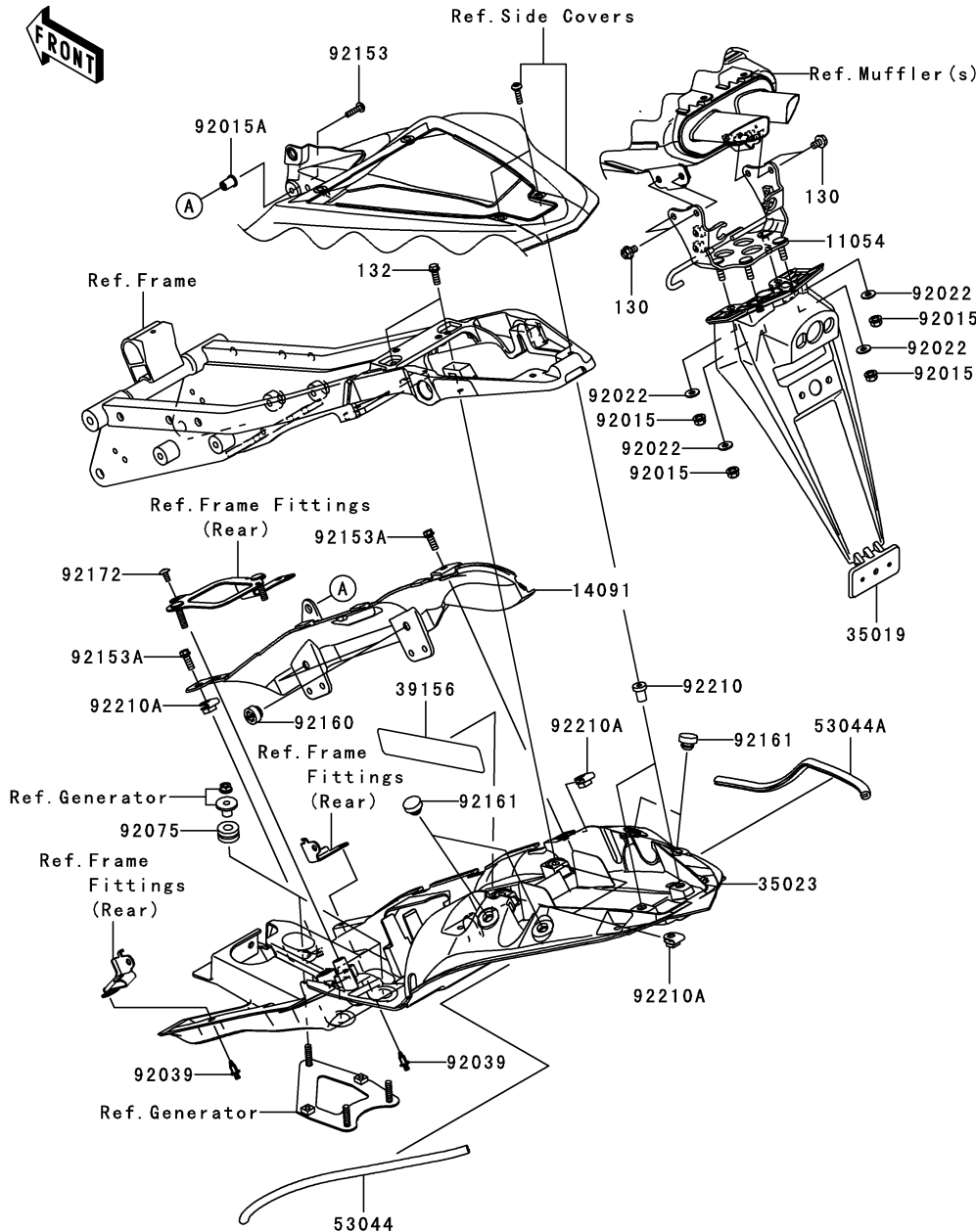

Ref. No.	Part No.	Description	Spec Code	Quantity-ZX600	
				'07	P7F
11054	11054-1773	BRACKET,FLAP			1
14091	14091-0795	COVER,HEAD GUARD			1
35019	35019-0061	FLAP			1
35023	35023-0115	FENDER-REAR			1
39156	39156-0261	PAD,SIDE COVER,RH,RR			1
53044	53044-1198	TRIM			1
53044A	53044-1284	TRIM,L=404			1
92015	92015-1603	NUT,LOCK,FLANGED,6MM			4
92015A	92015-1757	NUT,WELL,5MM			1
92022	92022-2373	WASHER,6.2X15.0X1.2			4
92039	92039-0023	RIVET			2
92075	92075-209	DAMPER			3
92153	92153-0873	BOLT,SOCKET,5X20			1
92153A	92153-1526	BOLT,SOCKET,6X16			2
92160	92160-1041	DAMPER			2
92161	92161-0046	DAMPER			4
92172	92172-1061	SCREW,TAPPING,5X10			1
92210	92210-0001	NUT,5MM			2
92210A	92210-1355	NUT,6MM			4
130	130BA0610	BOLT-FLANGED,6X10			4
132	132BA0616	BOLT-FLANGED-SMALL,6X16			2

F2190

Ref. No.	Part No.	Description	Spec Code	Quantity-ZX600			
				'07			
				P7F			

32043	32043-0043-18R	BRACKET-STAND,SIDE,BLACK		1
34024	34024-0001-18R	STAND-SIDE,BLACK		1
92015	92015-1188	NUT,LOCK,10MM,BLACK		1
92144	92144-1818	SPRING,SIDE STAND		1
92151	92151-1797	BOLT,SIDE STAND		1
92151A	92151-1802	BOLT,FLANGED,10X25		2
92191	92191-1001	TUBE,13X16X60		1

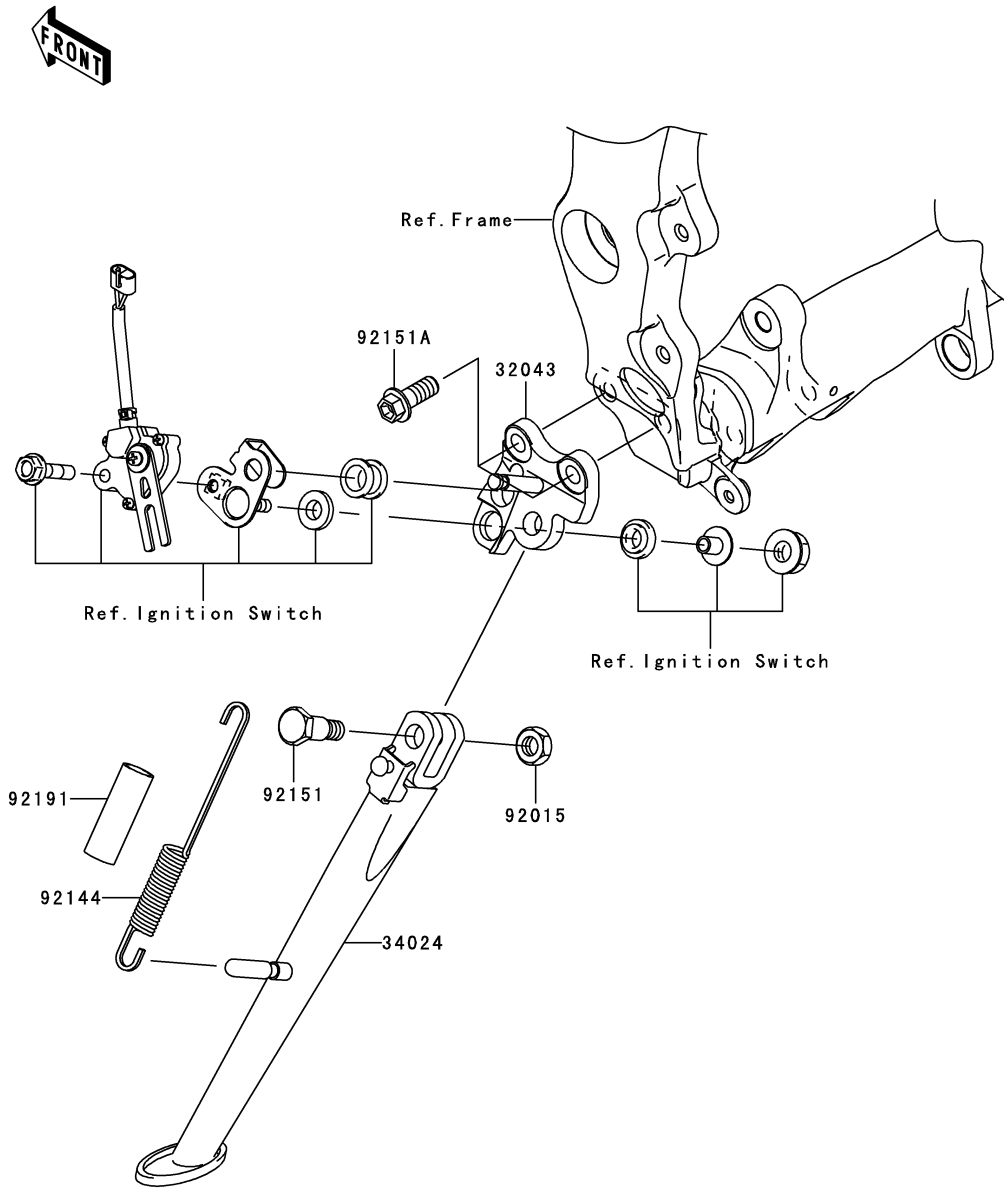

This catalog covers:

'07 ZX600P7F Chassis

GRID NO.

E-13

This grid covers:

Tires

F2210

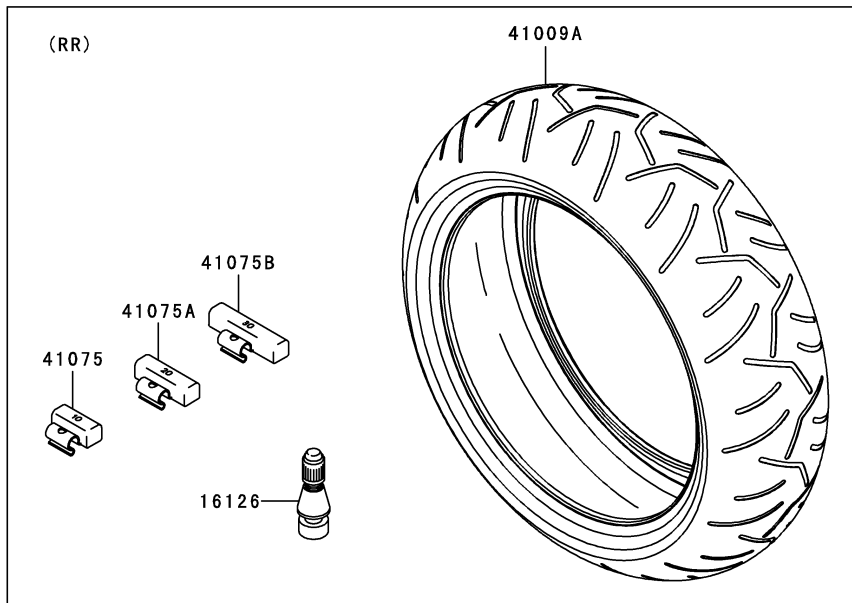
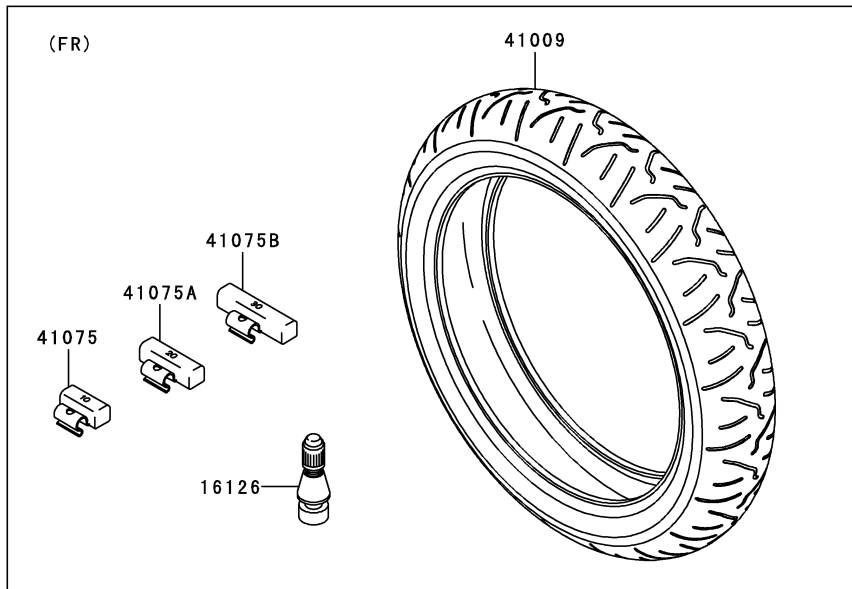

Ref. No.	Part No.	Description	Spec Code	Quantity-ZX600	
				'07	P7F
16126	16126-1140	VALVE,TIRE		2	
41009	41009-0139	TIRE,FR,120/70ZR17(58W),BT015F		1	
41009A	41009-0162	TIRE,RR,180/55ZR17(73W),BT015R		1	
41075	41075-0007	BALANCER-WHEEL,10G,SILVER		AR	
41075A	41075-0008	BALANCER-WHEEL,20G,SILVER		AR	
41075B	41075-0009	BALANCER-WHEEL,30G,SILVER		AR	

F2230

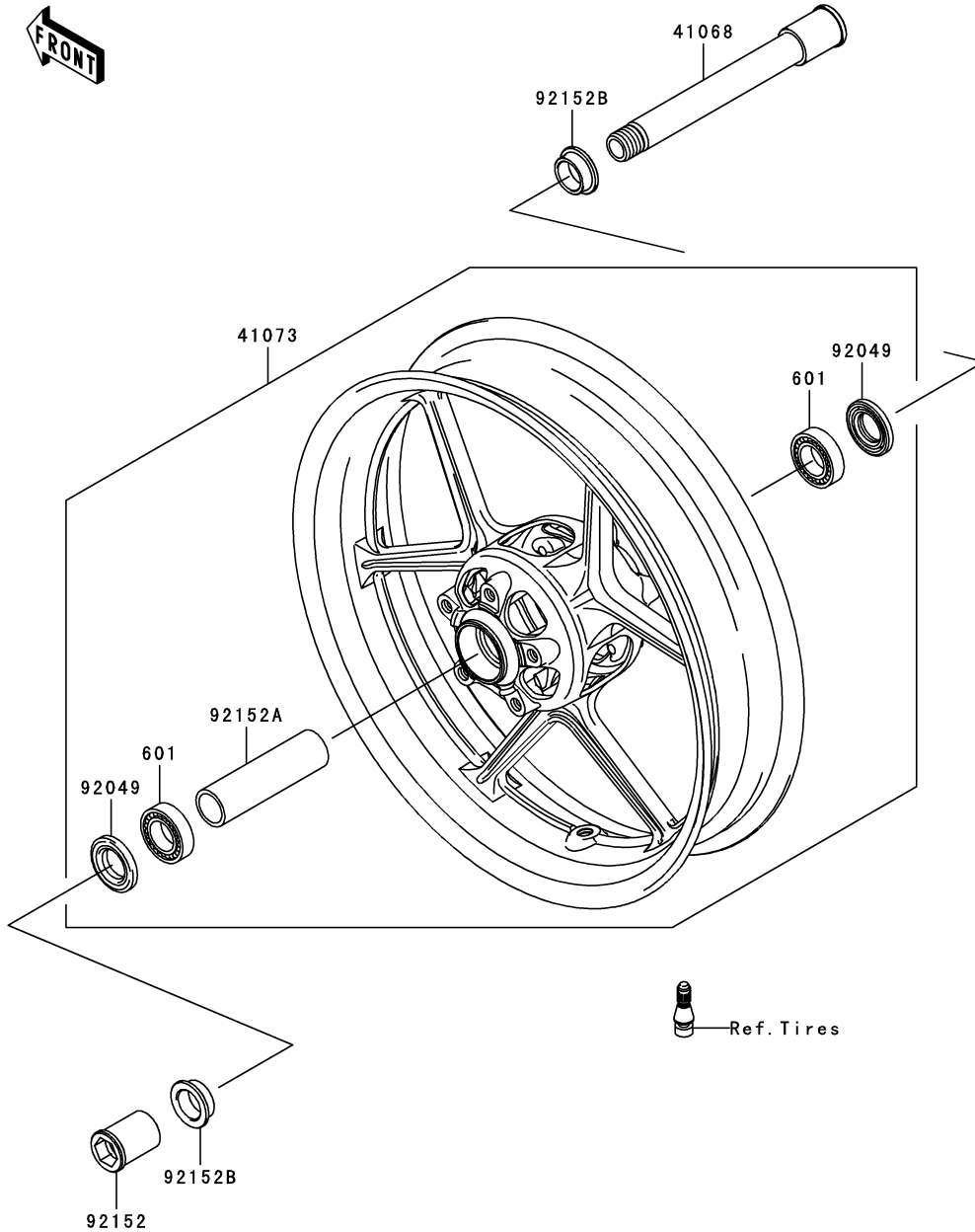

Ref. No.	Part No.	Description	Spec Code	Quantity-ZX600			
				'07			
41068	41068-0034	AXLE,FR					1
41073	41073-0107-18F	WHEEL-ASSY,FR,BLACK					1
92049	92049-1377	SEAL-OIL,BJN 32 47 5					2
92152	92152-0240	COLLAR,FR AXLE,LH,L=44.5					1
92152A	92152-0242	COLLAR,FR HUB,L=115					1
92152B	92152-0289	COLLAR,FR AXLE,L=13					2
601	601B6005UU	BEARING-BALL,#6005UU					2

This catalog covers:
'07 ZX600P7F Chassis

GRID NO.

F-3

This grid covers:

Rear Hub

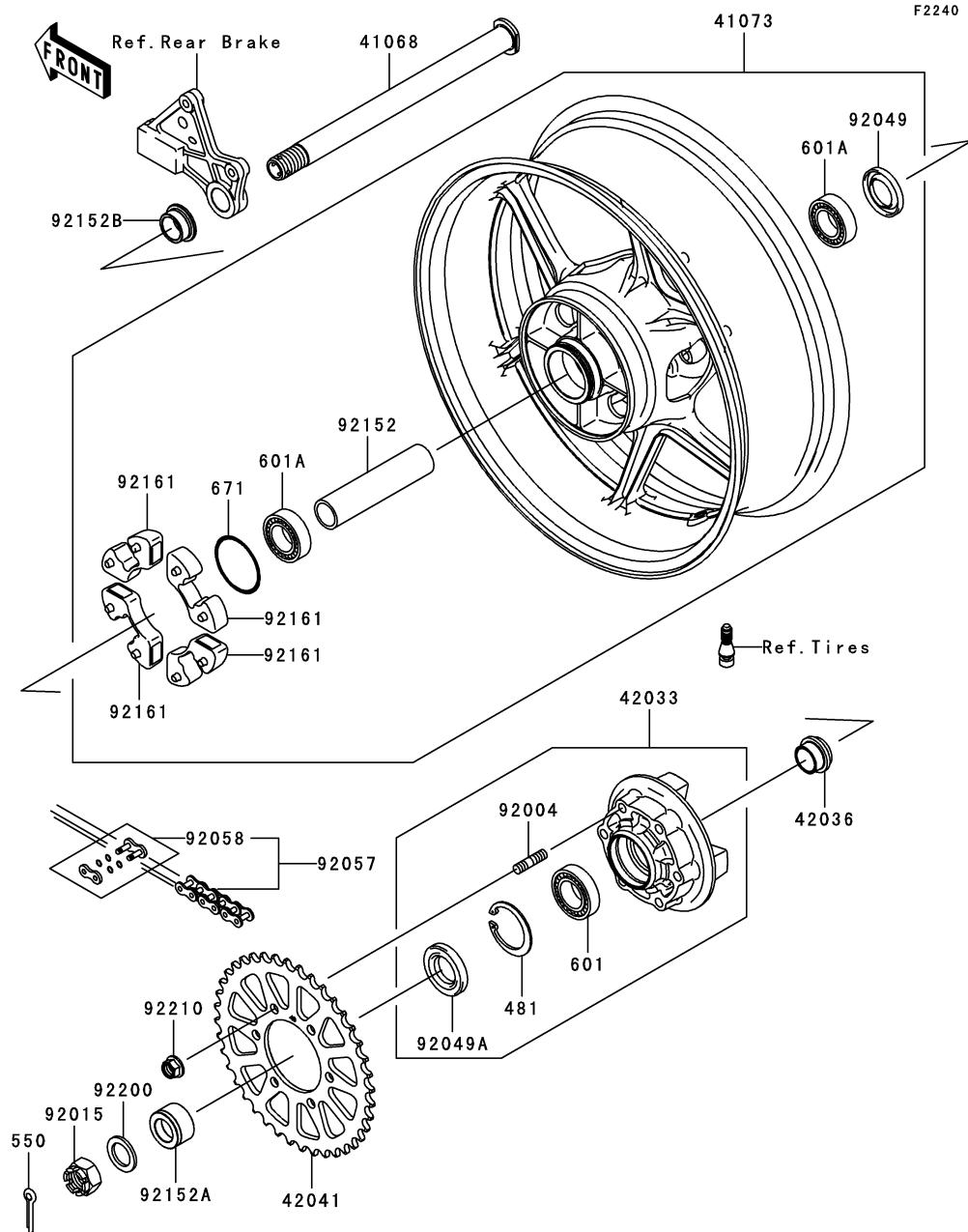

Ref. No.	Part No.	Description	Spec Code	Quantity-ZX600		
				'07	P7F	
41068	41068-0035	AXLE,RR			1	
41073	41073-0106-18F	WHEEL-ASSY,RR,BLACK			1	
42033	42033-0026	COUPLING-ASSY,RR HUB			1	
42036	42036-1279	SLEEVE,RR HUB,L=22			1	
42041	42041-0017	SPROCKET-HUB,43T			1	
92004	92004-1275	STUD,10X19			6	
92015	92015-1844	NUT,CASTLE,24MM			1	
92049	92049-1375	SEAL-OIL,RR HUB			1	
92049A	92049-1376	SEAL-OIL,PJN 40 55 8			1	
92057	92057-0129	CHAIN,DRIVE,EK520MVXL1X112L			1	
92058	92058-0007	JOINT-CHAIN,DRIVE			1	
92152	92152-0214	COLLAR,RR HUB,L=137			1	
92152A	92152-0543	COLLAR,RR HUB,LH,L=23.5			1	
92152B	92152-0544	COLLAR,RR HUB,RH,L=16			1	
92161	92161-0342	DAMPER,SHOCK,RR HUB			4	
92200	92200-1479	WASHER,25.5X38X3.2			1	
92210	92210-0276	NUT,LOCK,FLANGED,10MM			6	
481	481J5500	CIRCLIP			1	
550	550D4040	PIN-COTTER,4.0X40			1	
601	601B6006G	BEARING-BALL,#6006G			1	
601A	601B6205UU	BEARING-BALL			2	
671	671B2560	O RING,60MM			1	

F2260



Ref. No.	Part No.	Description	Spec Code	Quantity-ZX600			
				'07			
				P7F			

13236	13236-0135	LEVER-COMP,BRAKE PEDAL		1
92022	92022-1282	WASHER,7X28X1.6		1
92022A	92022-326	WASHER,15.3X24X1		1
92145	92145-0230	SPRING,BRAKE PEDAL RETURN		1
92190	92190-1185	TUBE,16X19X30		1
180	180L0614	BOLT-UPSET-WS,6X14		1

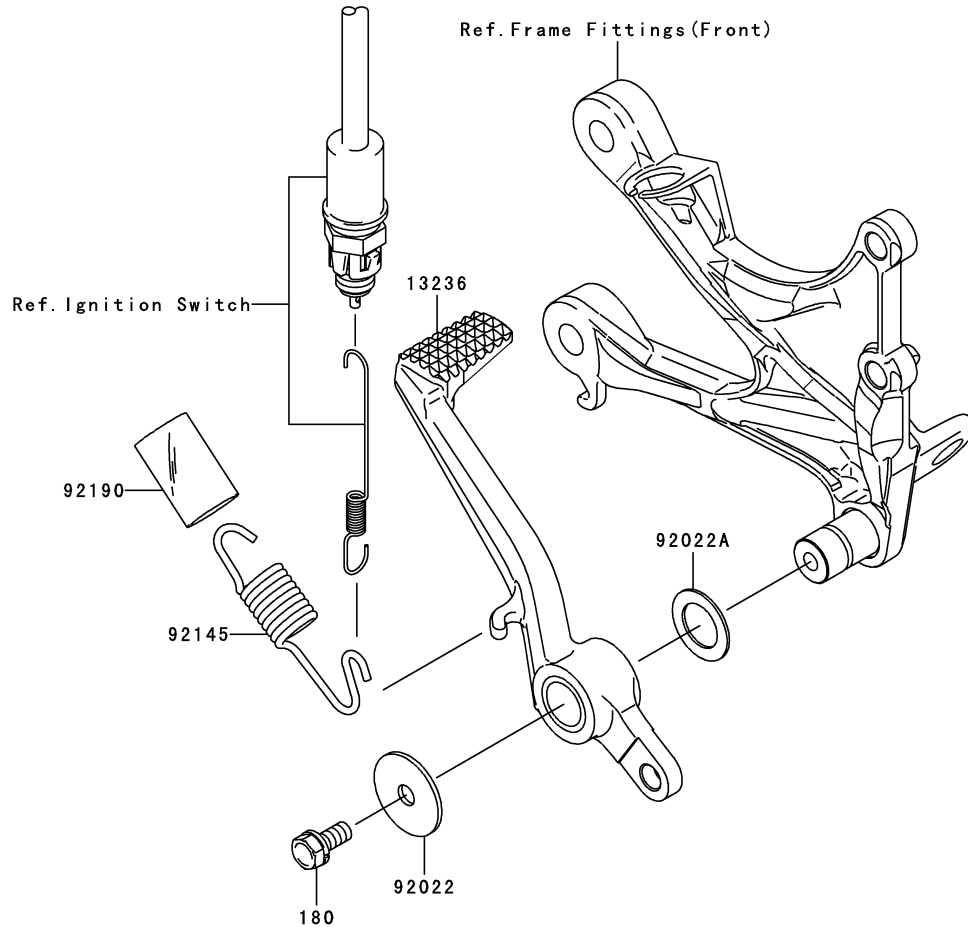

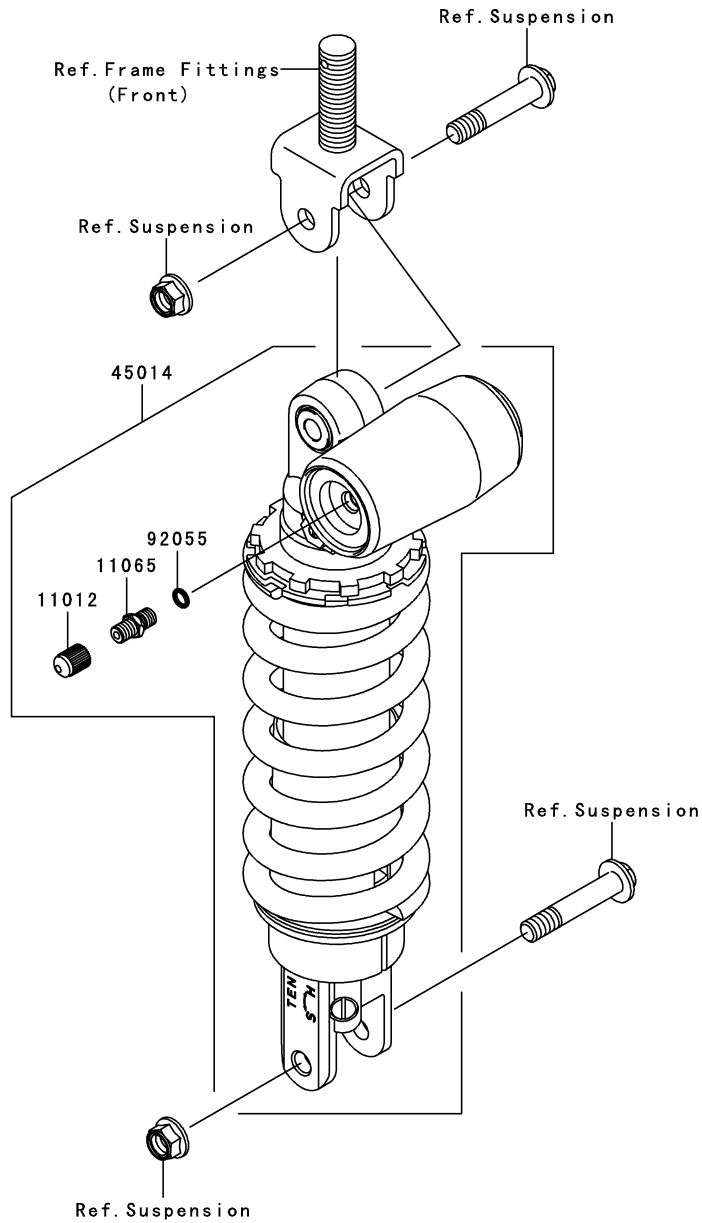

F2280

Ref. No.	Part No.	Description	Spec Code	Quantity-ZX600			
				'07			
11012	11012-1283	CAP					1
11065	11065-0009	CAP,AIR VALVE					1
45014	45014-0181-23A	SHOCK,SPRING,SIL+BODY,BLK					1
92055	92055-0002	RING-O					1

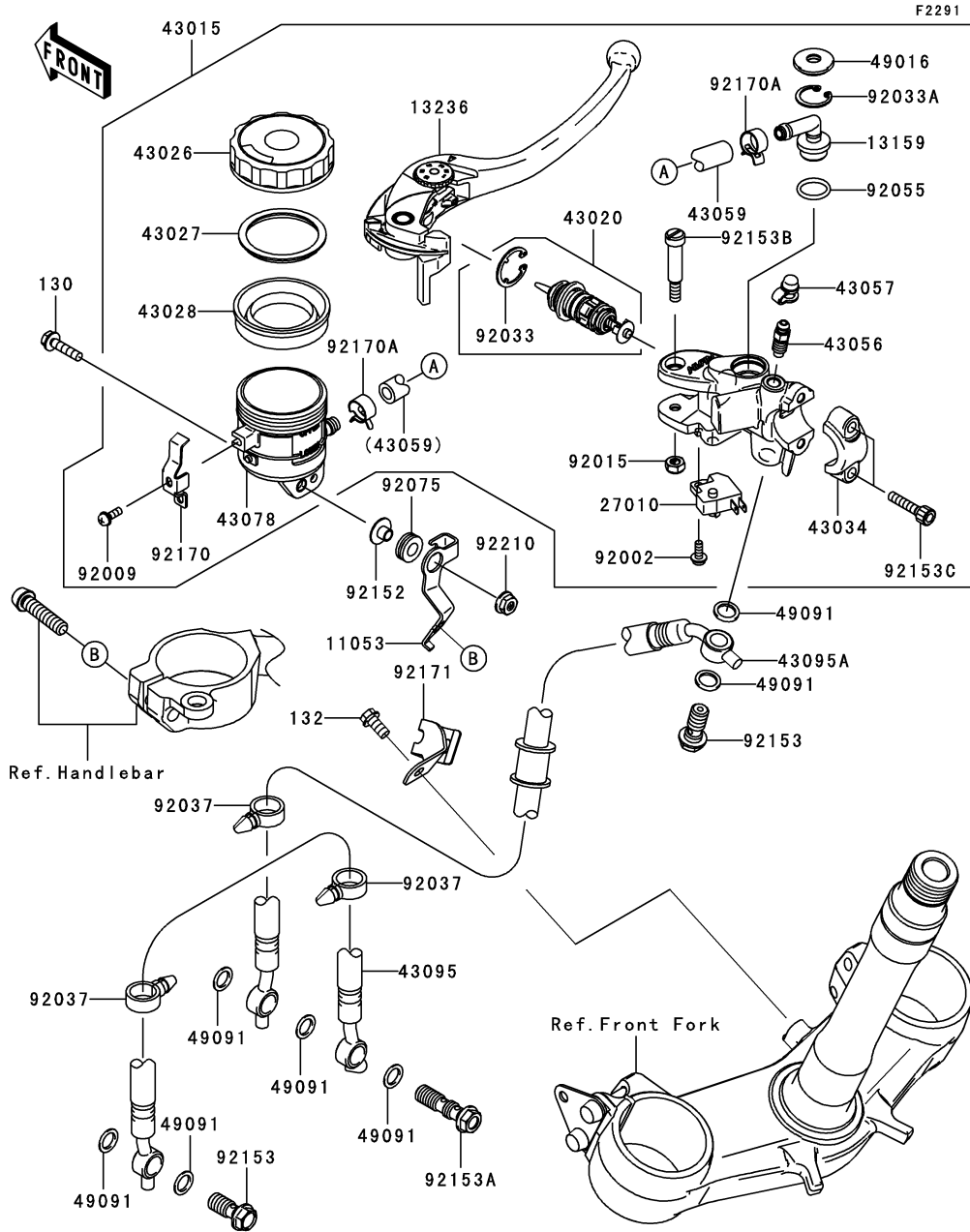

Ref. No.	Part No.	Description	Spec Code	Quantity-ZX600		
				'07		
				P7F		
11053	11053-1545	BRACKET,RESERVOIR TANK,FR				1
13159	13159-1061	CONNECTOR				1
13236	13236-0103	LEVER-COMP,FRONT BRAKE				1
27010	27010-0025	SWITCH,BRAKE				1
43015	43015-0097	CYLINDER-ASSY-MASTER,FR				1
43020	43020-0003	PISTON-COMP-BRAKE				1
43026	43026-1051	CAP-BRAKE				1
43027	43027-1051	PLATE-DIAPHRAGM				1
43028	43028-1057	DIAPHRAGM,MASTER CYLINDER				1
43034	43034-1016	HOLDER-BRAKE,MASTER CYLINDER				1
43056	43056-1056	BREATHER-BRAKE				1
43057	43057-1001	CAP-BREATHER				1
43059	43059-1696	HOSE-BRAKE,FR MASTER CYLINDER				1
43078	43078-1099	RESERVOIR				1
43095	43095-0303	HOSE-BRAKE,FR				1
43095A	43095-0356	HOSE-BRAKE,FR				1
49016	49016-1147	COVER-SEAL				1
49091	49091-0001	WASHER-SEAL,10.1X14.5X1.5				7
92002	92002-1323	BOLT,SCREW,4X12				1
92009	92009-1570	SCREW				1
92015	92015-1233	NUT,FLANGED,6MM,BLACK				1
92033	92033-0034	RING-SNAP				1
92033A	92033-1186	RING-SNAP,20.5MM				1
92037	92037-1827	CLAMP,HOSE				3
92055	92055-1251	RING-O,MASTER CYLINDER				1
92075	92075-161	DAMPER				1
92152	92152-0017	COLLAR				1
92153	92153-0627	BOLT,OIL,L=23				2
92153A	92153-0628	BOLT,OIL,L=37				1
92153B	92153-0868	BOLT,LEVER				1
92153C	92153-1518	BOLT,SOCKET,6X22				2
92170	92170-1090	CLAMP				1
92170A	92170-1091	CLAMP,HOSE				2
92171	92171-0406	CLAMP,BRAKE HOSE				1
92210	92210-0007	NUT,FLANGED,5MM				1
130	130L0520	BOLT-FLANGED,5X20				1
132	132J0612	BOLT-FLANGED-SMALL,6X12				1

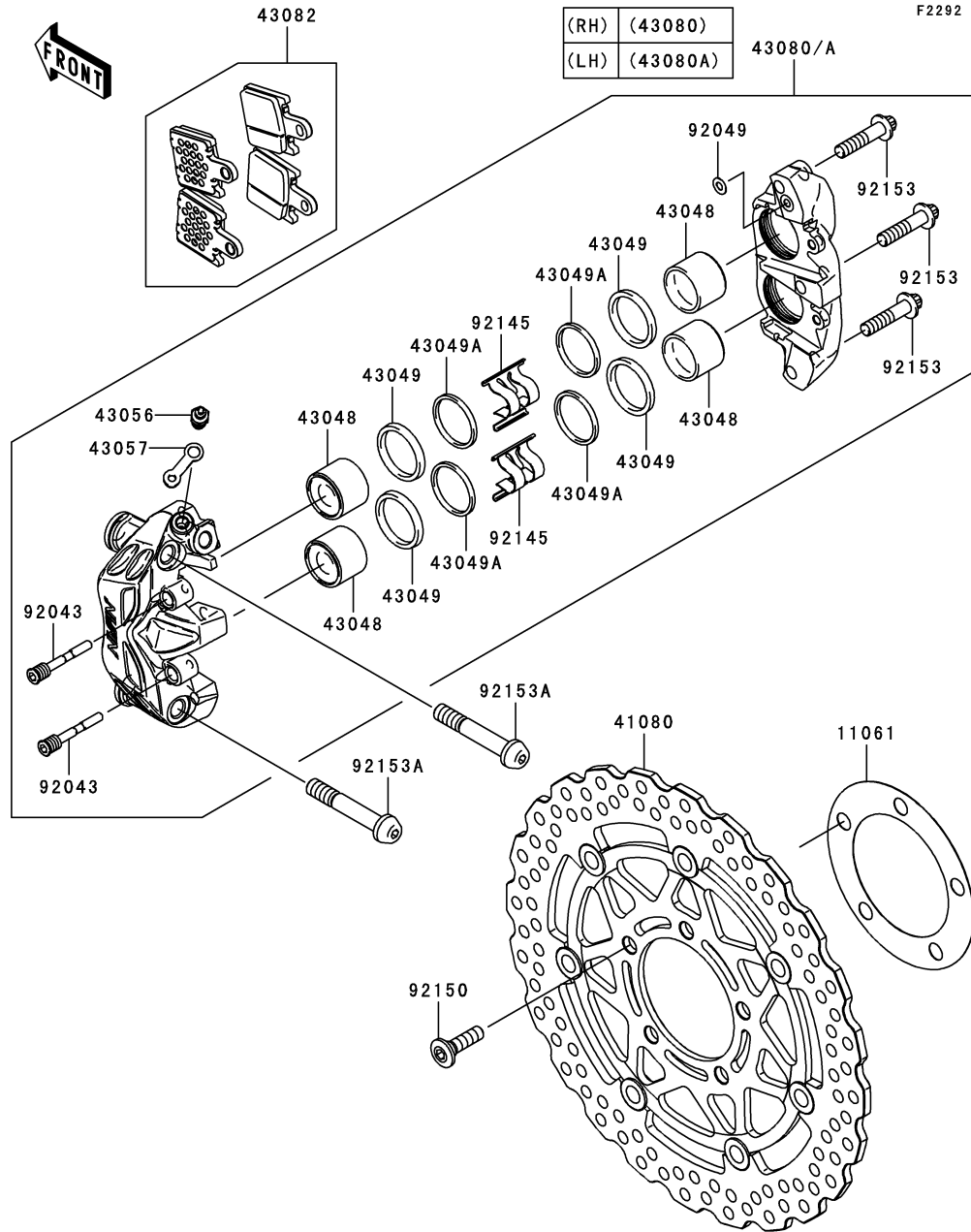

Ref. No.	Part No.	Description	Spec Code	Quantity-ZX600		
				'07		
11061	11061-0029	GASKET,DISC PLATE			2	
41080	41080-0077-5C	DISC,FR,HOUSING BLK+DISC SIL			2	
43048	43048-0005	PISTON-CALIPER			8	
43049	43049-0006	PACKING			8	
43049A	43049-0007	PACKING			8	
43056	43056-1055	BREATHER			2	
43057	43057-1001	CAP-BREATHER			2	
43080	43080-0046-DJ	CALIPER-SUB-ASSY,FR,RH,BLACK			1	
43080A	43080-0047-DJ	CALIPER-SUB-ASSY,FR,LH,BLACK			1	
43082	43082-0072	PAD-ASSY-BRAKE			2	
92043	92043-0105	PIN,PAD			4	
92049	92049-1448	SEAL-OIL			2	
92145	92145-0436	SPRING,PAD			4	
92150	92150-1771	BOLT,SOCKET,8X30			10	
92153	92153-1093	BOLT,TORX,8X38			6	
92153A	92153-1837	BOLT,SOCKET,10X60			4	

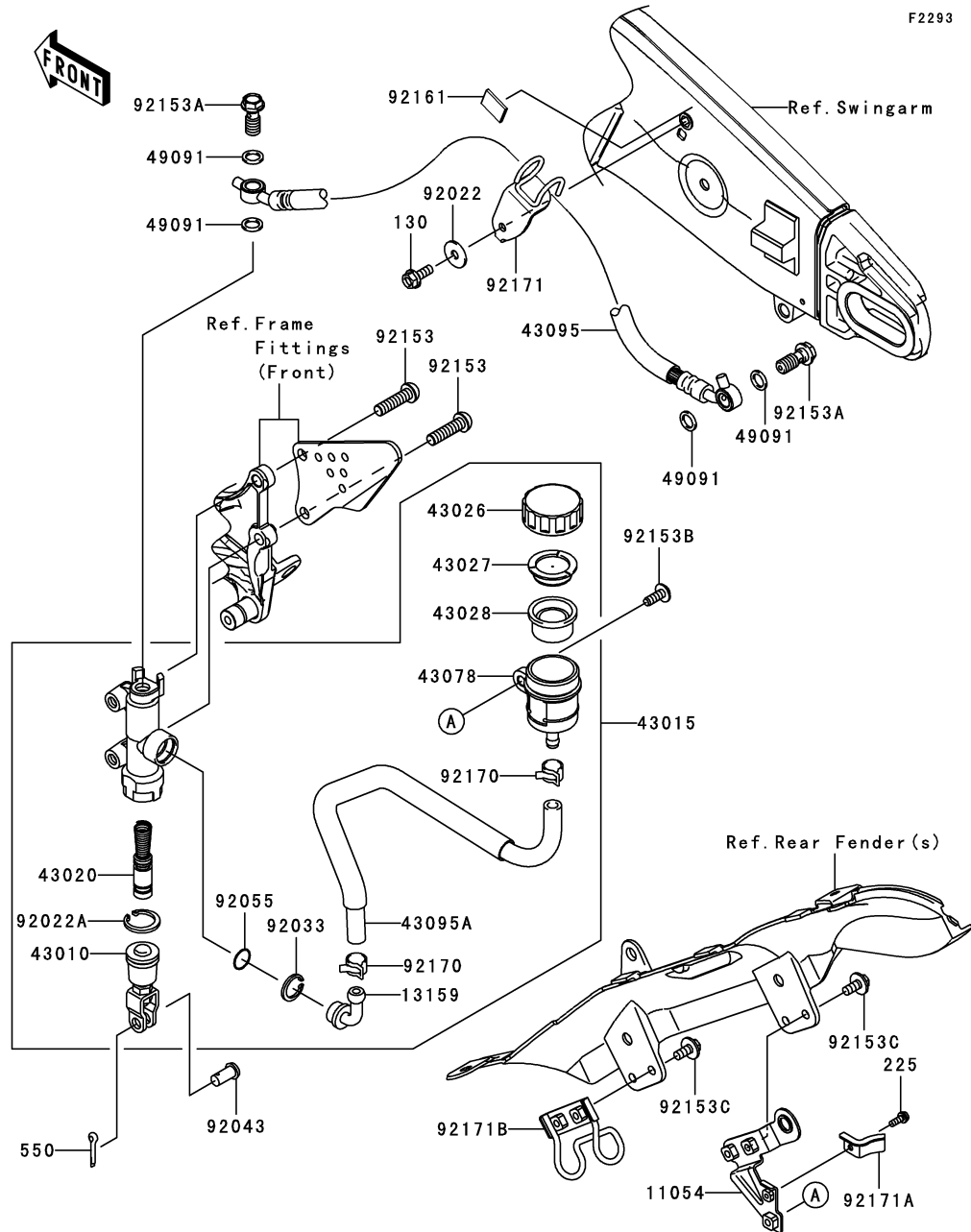

F2293

Ref. No.	Part No.	Description	Spec Code	Quantity-ZX600	
				'07	P7F
11054	11054-0755	BRACKET,RESERVOIR TANK		1	
13159	13159-1056	CONNECTOR		1	
43010	43010-1062	ROD-ASSY-BRAKE		1	
43015	43015-0096	CYLINDER-ASSY-MASTER,RR		1	
43020	43020-1094	PISTON-COMP-BRAKE		1	
43026	43026-0009	CAP-BRAKE		1	
43027	43027-1053	PLATE-DIAPHRAGM		1	
43028	43028-1065	DIAPHRAGM		1	
43078	43078-0040	RESERVOIR		1	
43095	43095-0289	HOSE-BRAKE,RR		1	
43095A	43095-0315	HOSE-BRAKE,RR M/CYLINDER		1	
49091	49091-0001	WASHER-SEAL,10.1X14.5X1.5		4	
92022	92022-1346	WASHER,6.5X20X1.6,BLACK		1	
92022A	92022-1601	WASHER,CIRCRIP		1	
92033	92033-1186	RING-SNAP,20.5MM		1	
92043	92043-0104	PIN,8X17		1	
92055	92055-1251	RING-O,MASTER CYLINDER		1	
92153	92153-0393	BOLT,SOCKET,8X30		2	
92153A	92153-0627	BOLT,OIL,L=23		2	
92153B	92153-0817	BOLT,8X16		1	
92153C	92153-1857	BOLT,FLANGED,6X14		4	
92161	92161-0273	DAMPER		1	
92170	92170-1091	CLAMP,HOSE		2	
92171	92171-0480	CLAMP,BRAKE HOSE		1	
92171A	92171-0776	CLAMP,RESERVOIR TANK		1	
92171B	92171-0778	CLAMP,HOSE		1	
130	130L0616	BOLT-FLANGED,6X16		1	
225	225F0412	SCREW-PAN-WSP-CROS,4X12		1	
550	550D2015	PIN-COTTER,2.0X15		1	

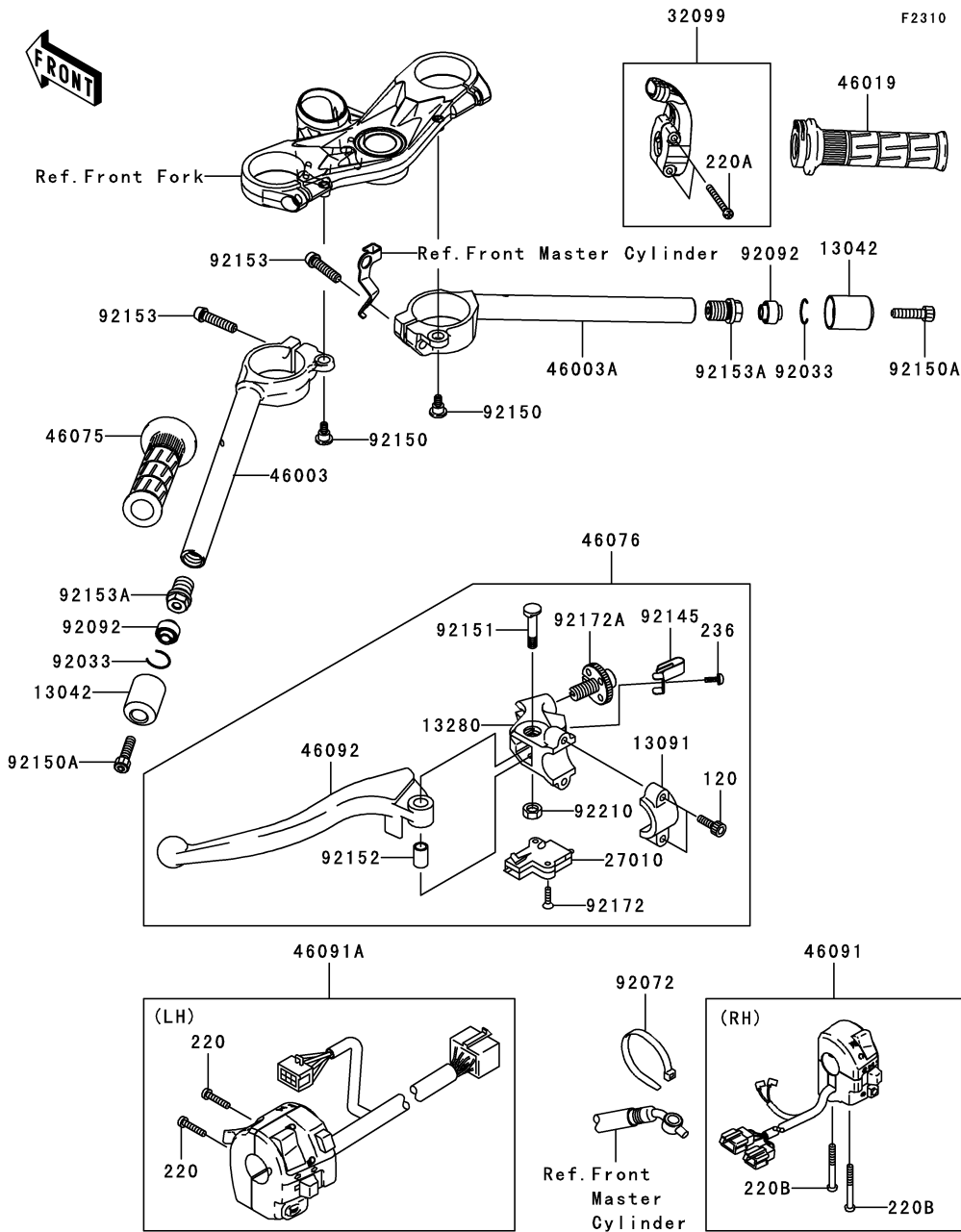

Ref. No.	Part No.	Description	Spec Code	Quantity-ZX600		
				'07	P7F	
13042	13042-1133	WEIGHT,HANDLE		2		
13091	13091-1624	HOLDER,CLUTCH LEVER		1		
13280	13280-1160	HOLDER,CLUTCH LEVER		1		
27010	27010-1492	SWITCH,CLUTCH		1		
32099	32099-1193	CASE,THROTTLE CABLE		1		
46003	46003-0136	HANDLE,LH		1		
46003A	46003-0137	HANDLE,RH		1		
46019	46019-0001	GRIP-ASSY,THROTTLE		1		
46075	46075-1144	GRIP,LH		1		
46076	46076-0033	LEVER-ASSY-GRIP,CLUTCH		1		
46091	46091-0114	HOUSING-ASSY-CONTROL,RH		1		
46091A	46091-0115	HOUSING-ASSY-CONTROL,LH		1		
46092	46092-0006	LEVER-GRIP,CLUTCH		1		
92033	92033-1102	RING-SNAP,OD=22.2		2		
92072	92072-1195	BAND,L=202		1		
92092	92092-1075	BUSHING-RUBBER,HANDLE		2		
92145	92145-1286	SPRING		1		
92150	92150-1090	BOLT,6MM		2		
92150A	92150-1604	BOLT,SOCKET,8X30		2		
92151	92151-1523	BOLT		1		
92152	92152-0103	COLLAR		1		
92153	92153-0907	BOLT,SOCKET,8X35		2		
92153A	92153-1667	BOLT,17X18		2		
92172	92172-0183	SCREW,3X16		2		
92172A	92172-1060	SCREW,ADJUST NUT		1		
92210	92210-0006	NUT,LOCK,6MM		1		
120	120P0620	BOLT-SOCKET,6X20		2		
220	220C0525	SCREW-PAN-CROS,5X25		2		
220A	220C0535	SCREW-PAN-CROS,5X35		2		
220B	220C0545	SCREW-PAN-CROS,5X45		2		
236	236C0410	SCREW-PAN-WSP-CROS,4X10		1		

F2340

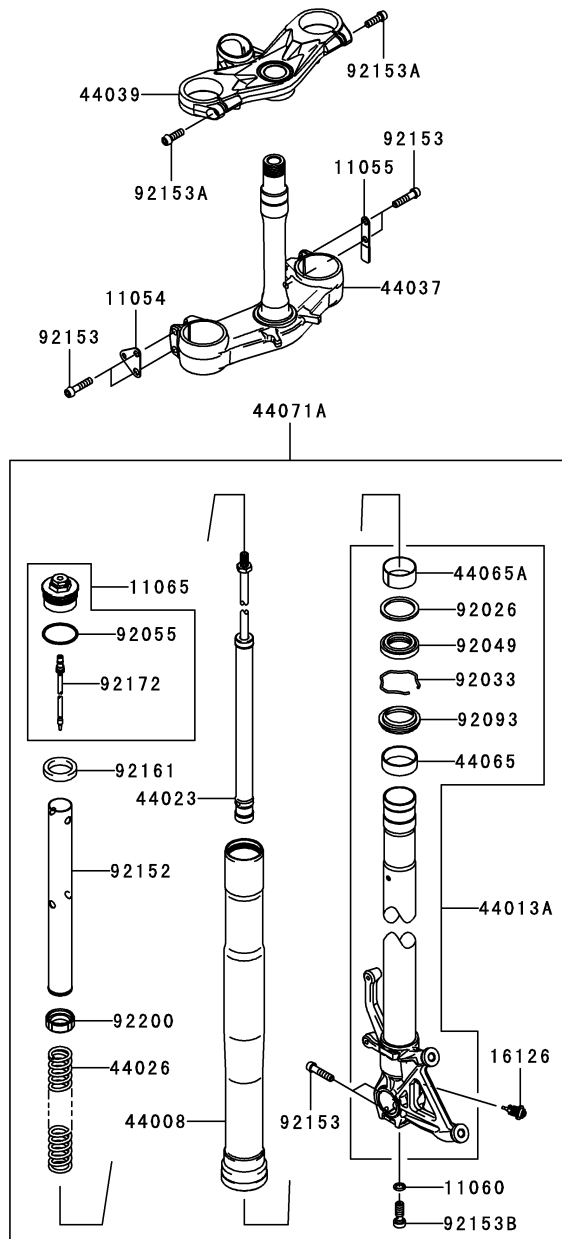
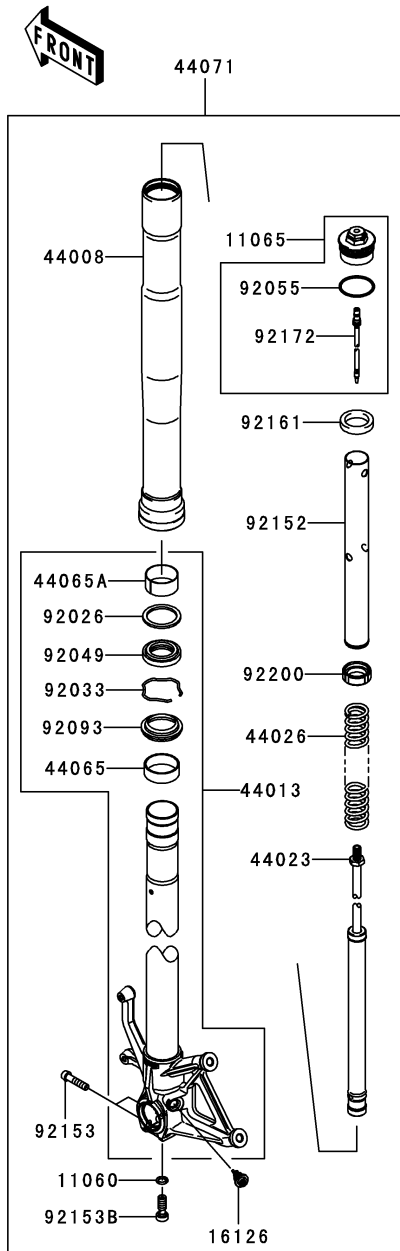

Ref. No.	Part No.	Description	Spec Code	Quantity-ZX600		
				'07		
				P7F		
11054	11054-0880	BRACKET			1	
11055	11055-0002	BRACKET			1	
11060	11060-1180	GASKET,FORK CYLINDER BOLT			2	
11065	11065-0184-KX	CAP,FORK,SILVER			2	
16126	16126-0031	VALVE,FORK			2	
44008	44008-0028-KX	PIPE-FORK OUTER,SILVER			2	
44013	44013-0071-18R	PIPE-FORK INNER,LH,BLACK			1	
44013A	44013-0072-18R	PIPE-FORK INNER,RH,BLACK			1	
44023	44023-0051	CYLINDER-SET-FORK			2	
44026	44026-0100	SPRING-FRONT FORK			2	
44037	44037-0074	HOLDER-FORK UNDER			1	
44039	44039-0068-829	HOLDER-FORK UPPER,GOLD			1	
44065	44065-0001	BUSHING-FRONT FORK,GUIDE			2	
44065A	44065-0002	BUSHING-FRONT FORK,SLIDE			2	
44071	44071-5038	DAMPER-ASSY,FORK,LH,SILVER			1	
44071A	44071-5039	DAMPER-ASSY,FORK,RH,SILVER			1	
92026	92026-1276	SPACER,FORK OUTER			2	
92033	92033-1222	RING-SNAP			2	
92049	92049-0058	SEAL-OIL			2	
92055	92055-0142	RING-O			2	
92093	92093-0035	SEAL,DUST			2	
92152	92152-0522	COLLAR,FORK,L=432			2	
92153	92153-0854	BOLT			8	
92153A	92153-0855	BOLT			2	
92153B	92153-1771	BOLT			2	
92161	92161-0440	DAMPER			2	
92172	92172-0290	SCREW			2	
92200	92200-0343	WASHER			2	

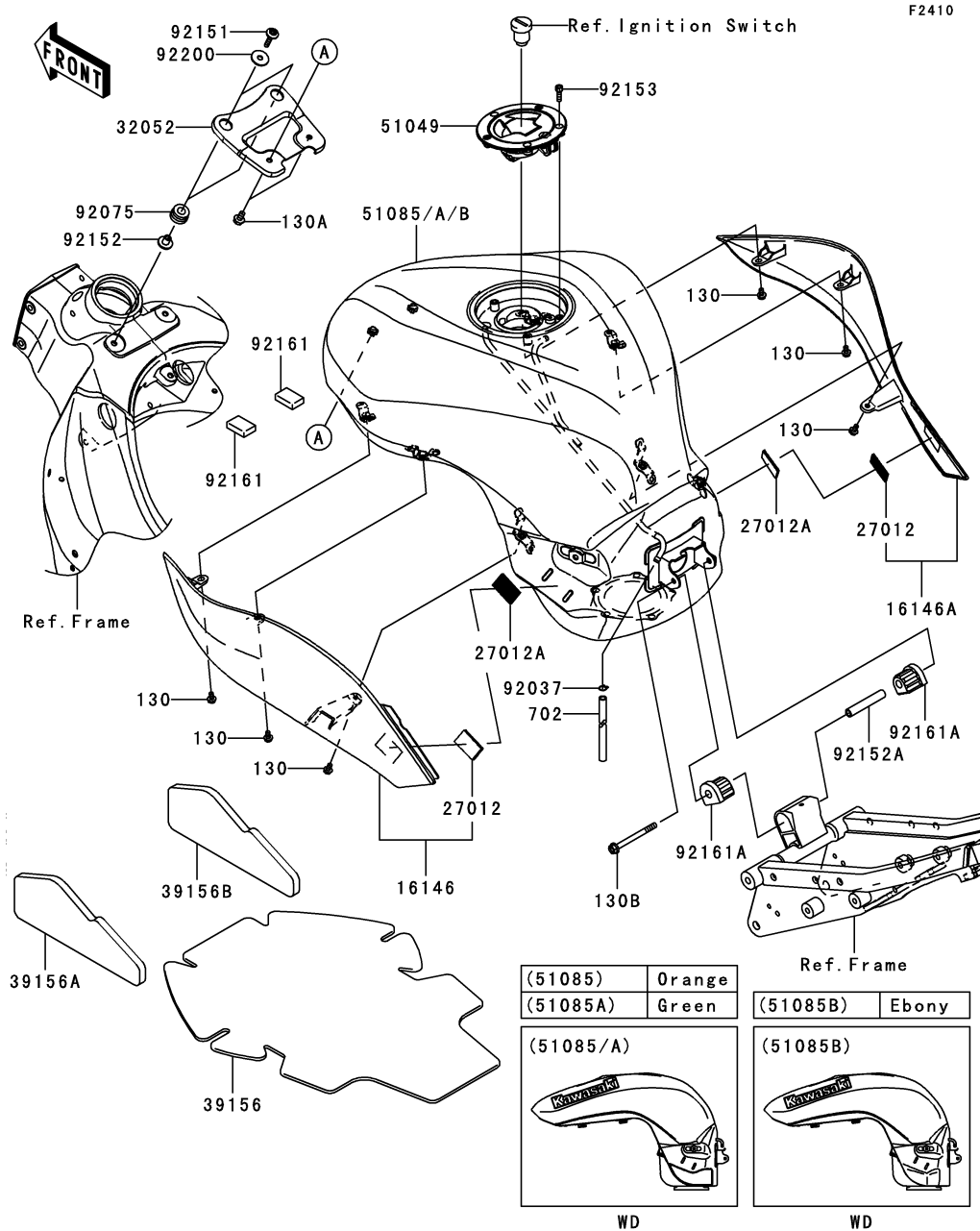

F2410

Ref. No.	Part No.	Description	Spec Code	Quantity-ZX600		
				'07		
				P7F		
16146	16146-0041	COVER-ASSY,KNEE GRIP,LH			1	
16146A	16146-0042	COVER-ASSY,KNEE GRIP,RH			1	
27012	27012-0091	HOOK			2	
27012A	27012-0115	HOOK			2	
32052	32052-0069-18R	BRACKET-TANK,FR,BLACK			1	
39156	39156-0252	PAD,FUEL TANK,LWR			1	
39156A	39156-0271	PAD,KNEE GRIP COVER,LH			1	
39156B	39156-0272	PAD,KNEE GRIP COVER,RH			1	
51049	51049-0014	CAP-TANK,FUEL			1	
51085	51085-5141-17H	TANK-COMP-FUEL,P.ORANGE			1	
51085A	51085-5141-777	TANK-COMP-FUEL,L.GREEN			1	
51085B	51085-5144-H8	TANK-COMP-FUEL,EBONY			1	
92037	92037-010	CLAMP,TUBE			1	
92075	92075-1123	DAMPER,RUBBER			2	
92151	92151-1611	BOLT,SOCKET,6X25			2	
92152	92152-0091	COLLAR			2	
92152A	92152-1182	COLLAR,6.8X10X60			1	
92153	92153-1616	BOLT,SOCKET,5X16			3	
92161	92161-0518	DAMPER			2	
92161A	92161-1330	DAMPER,FUEL TANK,RR			2	
92200	92200-1087	WASHER,6.5X22X1.6			2	
130	130BA0510	BOLT-FLANGED,5X10			6	
130A	130L0610	BOLT-FLANGED,6X10			2	
130B	130L0670	BOLT-FLANGED,6X70			1	
702	702A06850	TUBE-RUBBER,6X850			1	

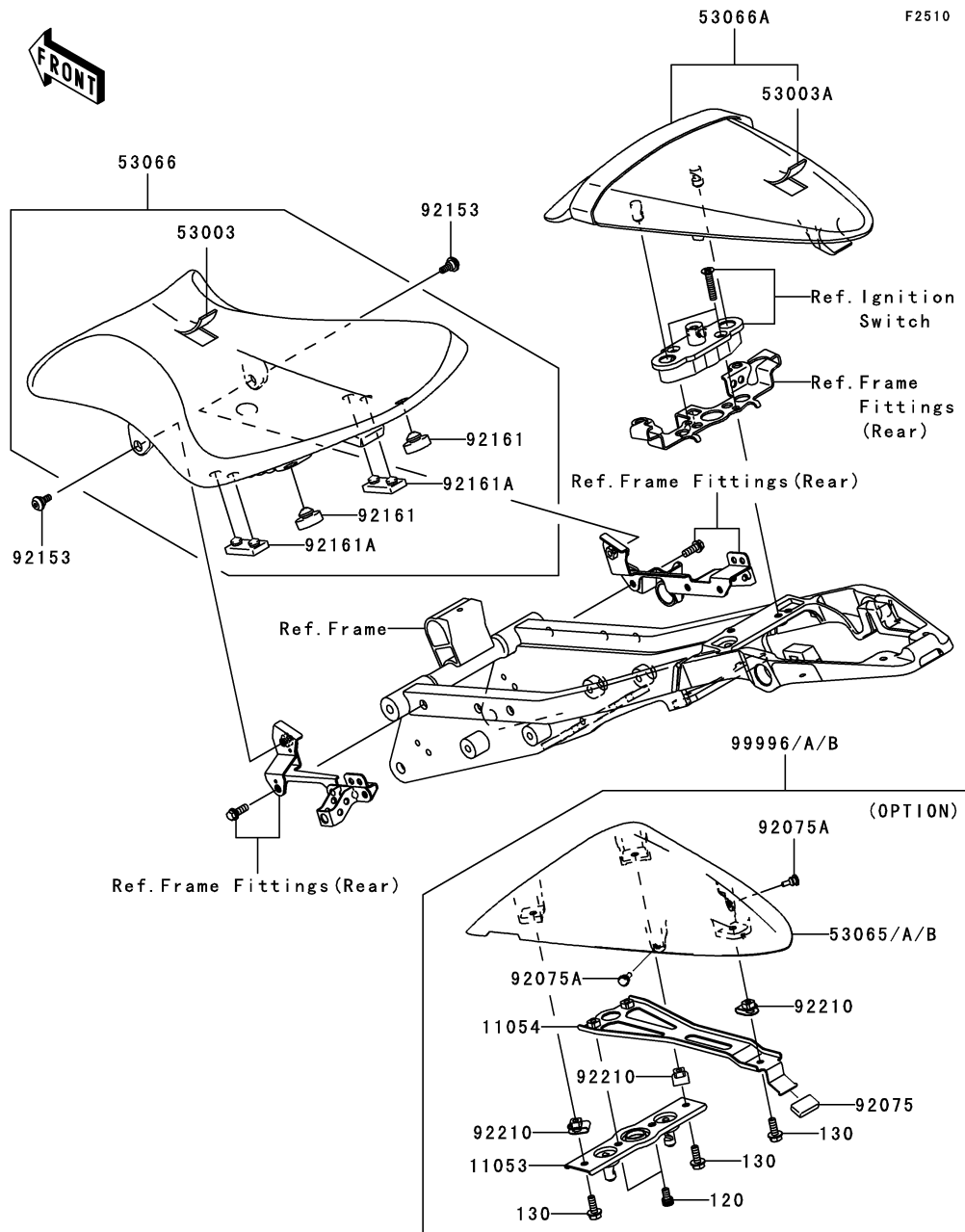

F2510

Ref. No.	Part No.	Description	Spec Code	Quantity-ZX600		
				'07	P7F	
11053	11053-0386 (OPTION)	BRACKET		1		
11054	11054-1942 (OPTION)	BRACKET,SINGLE SEAT COVER		1		
53003	53003-0098-MA	LEATHER,FRONT SEAT,BLACK		1		
53003A	53003-0099-MA	LEATHER,REAR SEAT,BLACK		1		
53065	53065-0010-H8 (OPTION)	COVER SEAT,EBONY		1		
53065A	53065-0010-17H (OPTION)	COVER SEAT,P.ORANGE		1		
53065B	53065-0010-777 (OPTION)	COVER SEAT,L.GREEN		1		
53066	53066-0178-MA	SEAT-ASSY,FR,BLACK		1		
53066A	53066-0187-12Y	SEAT,RR,LEATHER BLK+BAND BLK		1		
92075	92075-1446 (OPTION)	DAMPER		1		
92075A	92075-1808 (OPTION)	DAMPER		2		
92153	92153-0489	BOLT,SOCKET,6MM		2		
92161	92161-0095	DAMPER,SEAT		2		
92161A	92161-0149	DAMPER,SEAT		2		
92210	92210-1355 (OPTION)	NUT,6MM		3		
99996	99996-1354-H8 (OPTION)	KIT,SINGLE SEAT COVER,EBONY		1		
99996A	99996-1354-17H (OPTION)	KIT,SINGLE SEAT COVER,P.ORANGE		1		
99996B	99996-1354-777 (OPTION)	KIT,SINGLE SEAT COVER,L.GREEN		1		
120	120CA0610 (OPTION)	BOLT-SOCKET,6X10		2		
130	130BA0616 (OPTION)	BOLT-FLANGED,6X16		3		

F2530

Ref. No.	Part No.	Description	Spec Code	Quantity-ZX600			
				'07			
				P7F			
14091	14091-0711	COVER,METER,LWR					1
25023	25023-0029	COVER-METER CASE,UPP					1
25031	25031-0133	METER-ASSY,TACHO&LCD					1
28011	28011-0074	METER,TACHO&LCD					1
92009	92009-1164	SCREW,TAPPING,3X16					9
92009A	92009-1197	SCREW,TAPPING,5X14					3
92022	92022-1405	WASHER,5.5X20X1.2					3
92160	92160-1167	DAMPER					3

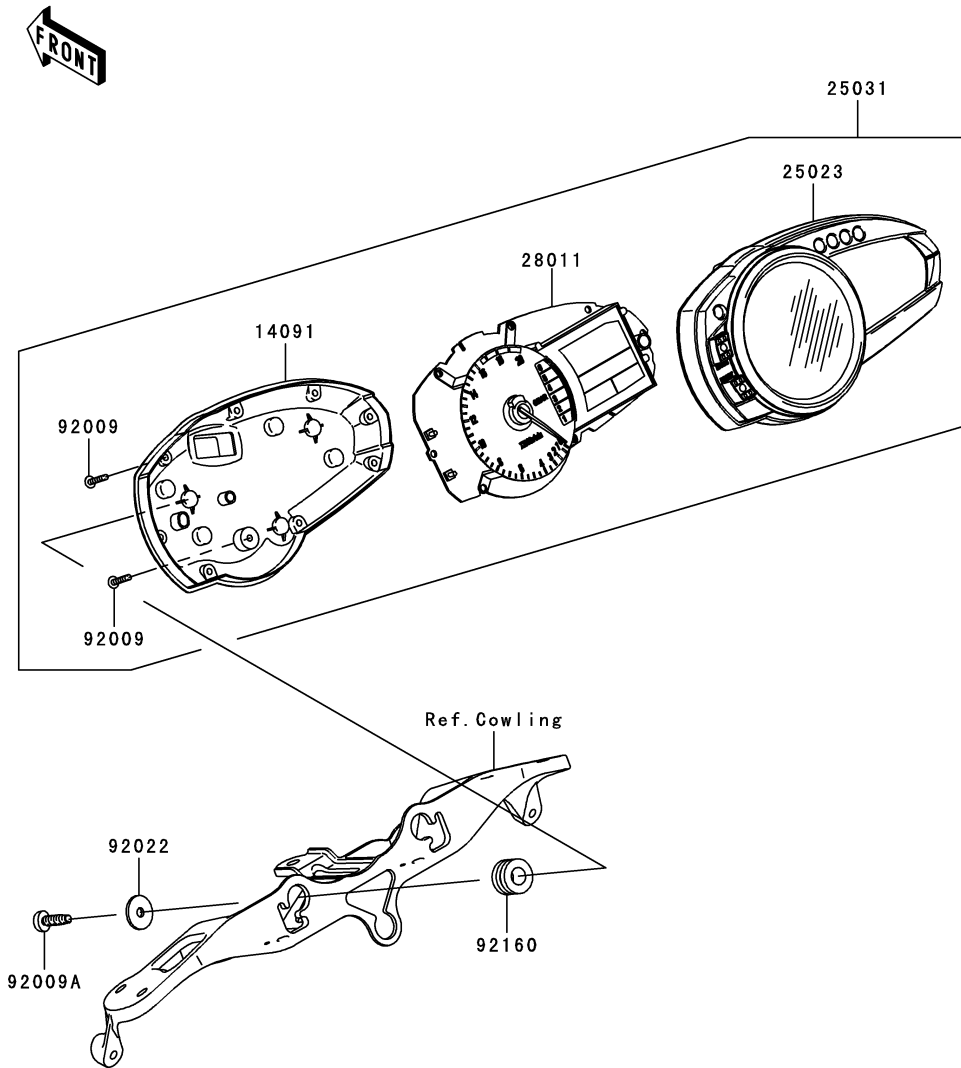

This catalog covers:
'07 ZX600P7F Chassis

GRID NO. This grid covers:

G-3 **Cables**

F2540

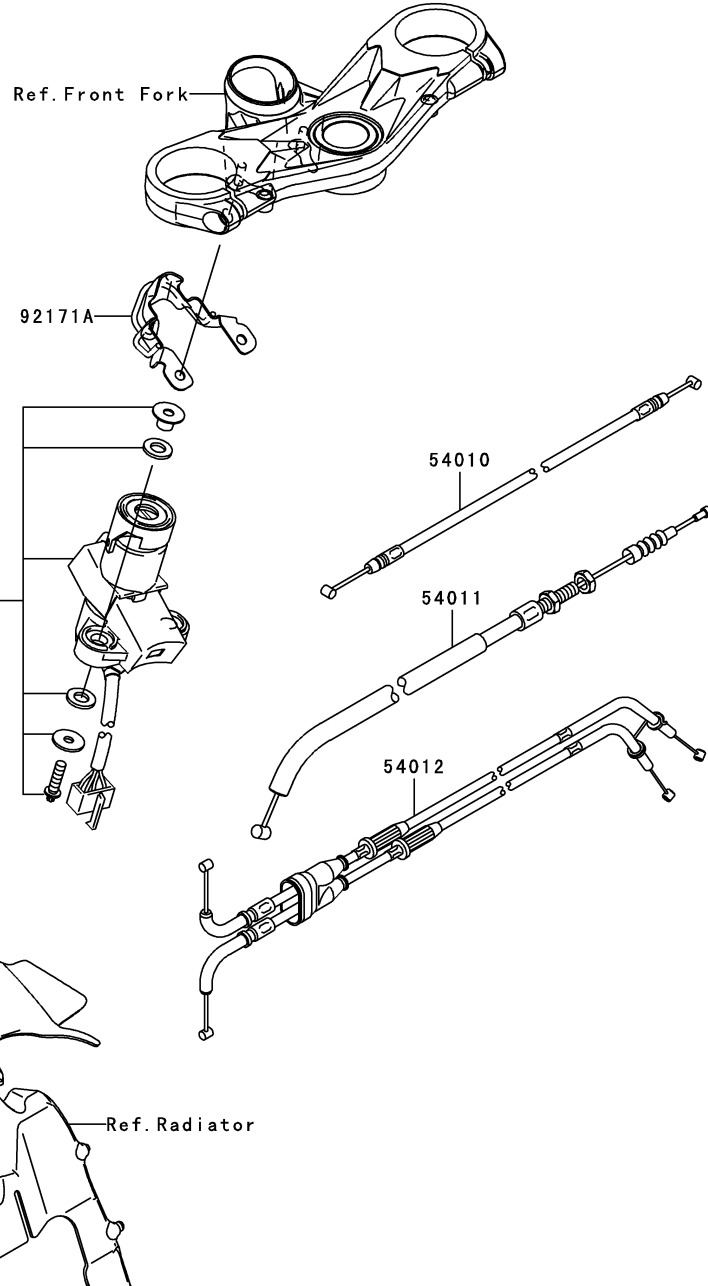

Ref. No.	Part No.	Description	Spec Code	Quantity-ZX600			
				'07			
54010	54010-0055	CABLE,SEAT LOCK				1	
54011	54011-0076	CABLE-CLUTCH				1	
54012	54012-0194	CABLE-THROTTLE				1	
92171	92171-0316	CLAMP,BRAKE HOSE				1	
92171A	92171-0912	CLAMP,CABLE				1	

This catalog covers:

'07 ZX600P7F Chassis

GRID NO.

G-4

This grid covers:

Side Covers

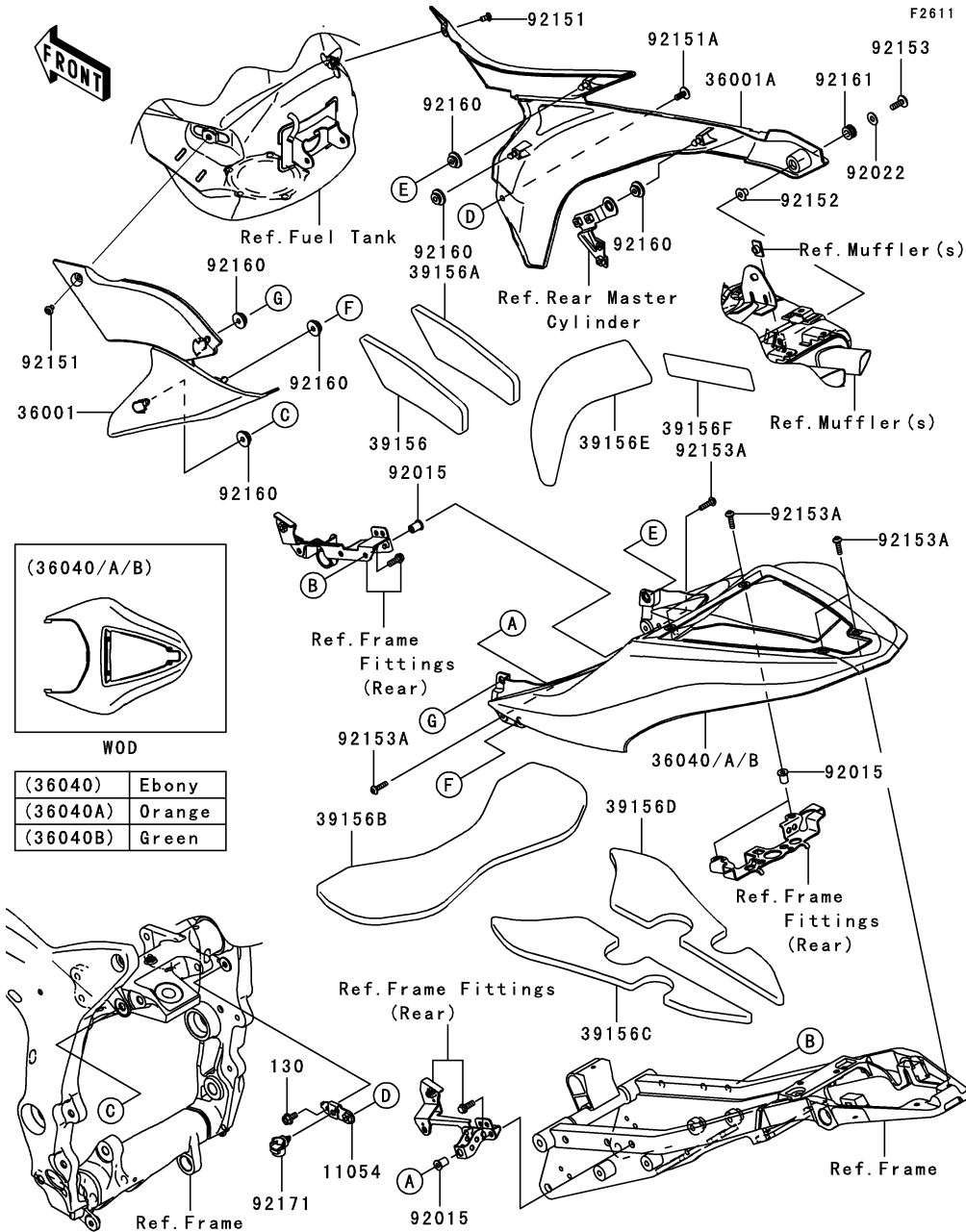

Ref. No.	Part No.	Description	Spec Code	Quantity-ZX600		
				'07		
11054	11054-1439	BRACKET,SIDE COVER				1
36001	36001-0103	COVER-SIDE,LH				1
36001A	36001-0121	COVER-SIDE,RH				1
36040	36040-0054-H8	COVER-TAIL,EBONY				1
36040A	36040-0054-17H	COVER-TAIL,P.ORANGE				1
36040B	36040-0054-777	COVER-TAIL,L.GREEN				1
39156	39156-0236	PAD,SIDE COVER,LH,UPP				1
39156A	39156-0237	PAD,SIDE COVER,RH,UPP				1
39156B	39156-0243	PAD,TAIL COVER,CNT				1
39156C	39156-0244	PAD,TAIL COVER,LH				1
39156D	39156-0245	PAD,TAIL COVER,RH				1
39156E	39156-0260	PAD,SIDE COVER,RH,LWR				1
39156F	39156-0261	PAD,SIDE COVER,RH,RR				1
92015	92015-1757	NUT,WELL,5MM				4
92022	92022-1093	WASHER,6.5X16X1.0				1
92151	92151-1219	BOLT,SOCKET,6X12				2
92151A	92151-1654	BOLT,SOCKET,6X14				1
92152	92152-0237	COLLAR				1
92153	92153-0816	BOLT,6X18				1
92153A	92153-0873	BOLT,SOCKET,5X20				6
92160	92160-1613	DAMPER				6
92161	92161-0204	DAMPER				1
92171	92171-1415	CLAMP,DIA=13				1
130	130BA0612	BOLT-FLANGED,6X12				1

This catalog covers:
'07 ZX600P7F Chassis

GRID NO. **G-5** This grid covers:
Chain Cover

F2650

Ref. No.	Part No.	Description	Spec Code	Quantity-ZX600			
				'07			
36014	36014-0020	CASE-CHAIN				1	
92071	92071-0020	GROMMET				1	
92151	92151-1654	BOLT,SOCKET,6X14				3	

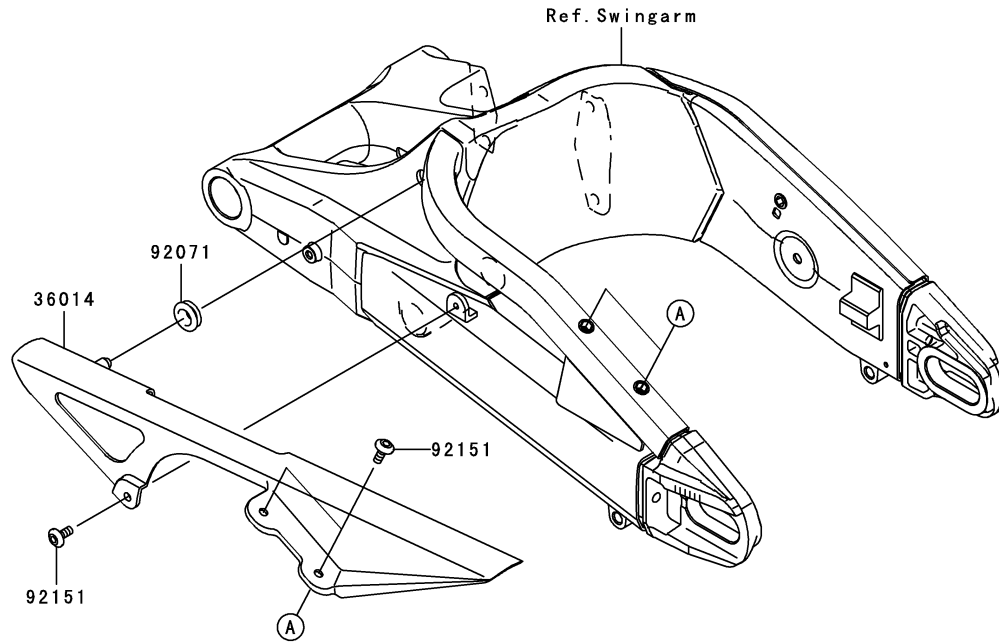

F2710

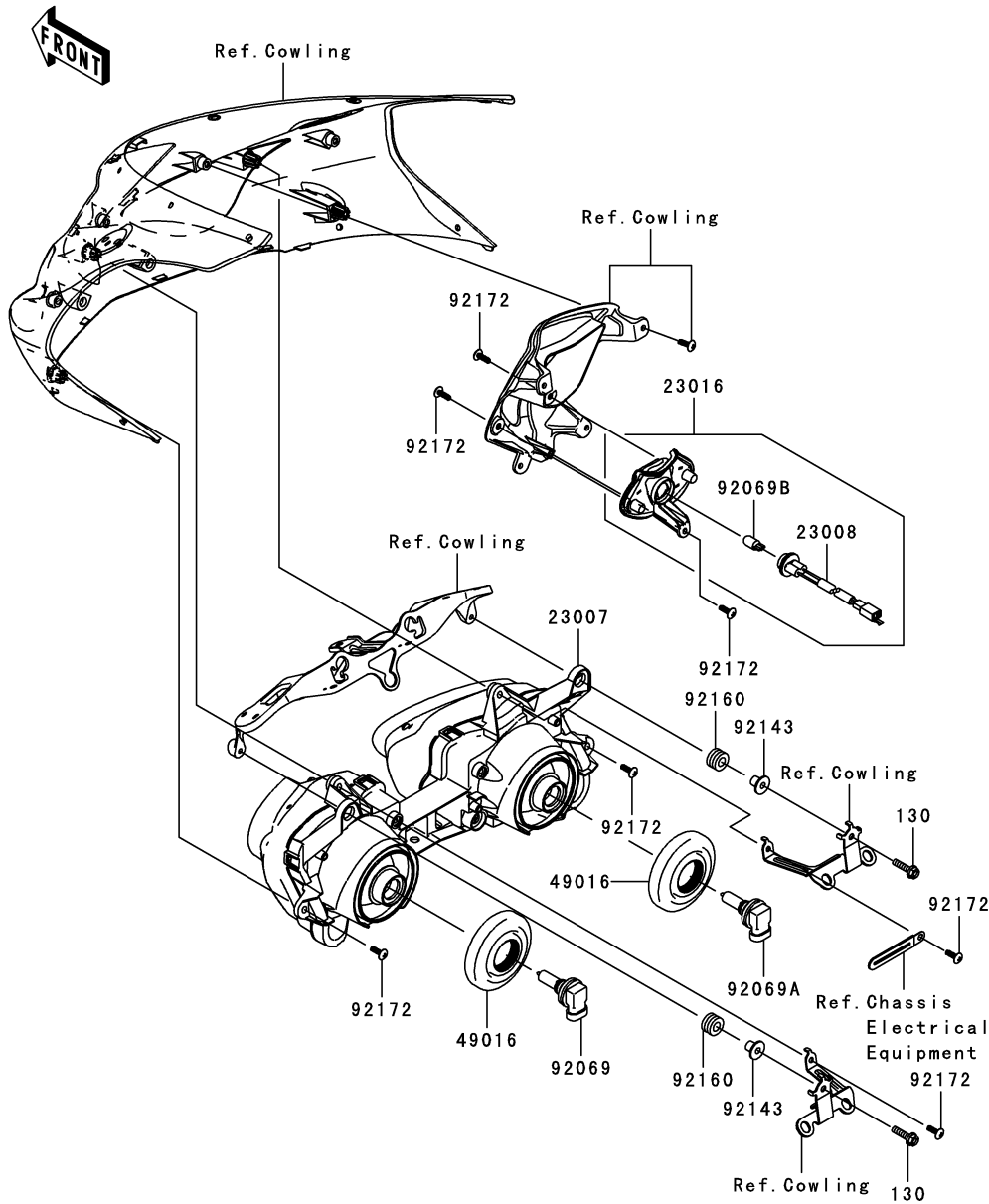

Ref. No.	Part No.	Description	Spec Code	Quantity-ZX600		
				'07		
23007	23007-0071	LENS-COMP,HEAD LAMP				1
23008	23008-0065	SOCKET-ASSY,POSITION LAMP				1
23016	23016-0012	LAMP-ASSY,POSITION				1
49016	49016-0023	COVER-SEAL,HEAD LAMP				2
92069	92069-0007	BULB,12V 65W,H9				1
92069A	92069-0014	BULB,12V 55W,H11				1
92069B	92069-1016	BULB,12V 5W				1
92143	92143-1353	COLLAR				2
92160	92160-1167	DAMPER				2
92172	92172-0175	SCREW,TAPPING,5X16				7
130	130BA0625	BOLT-FLANGED,6X25				2

F2720

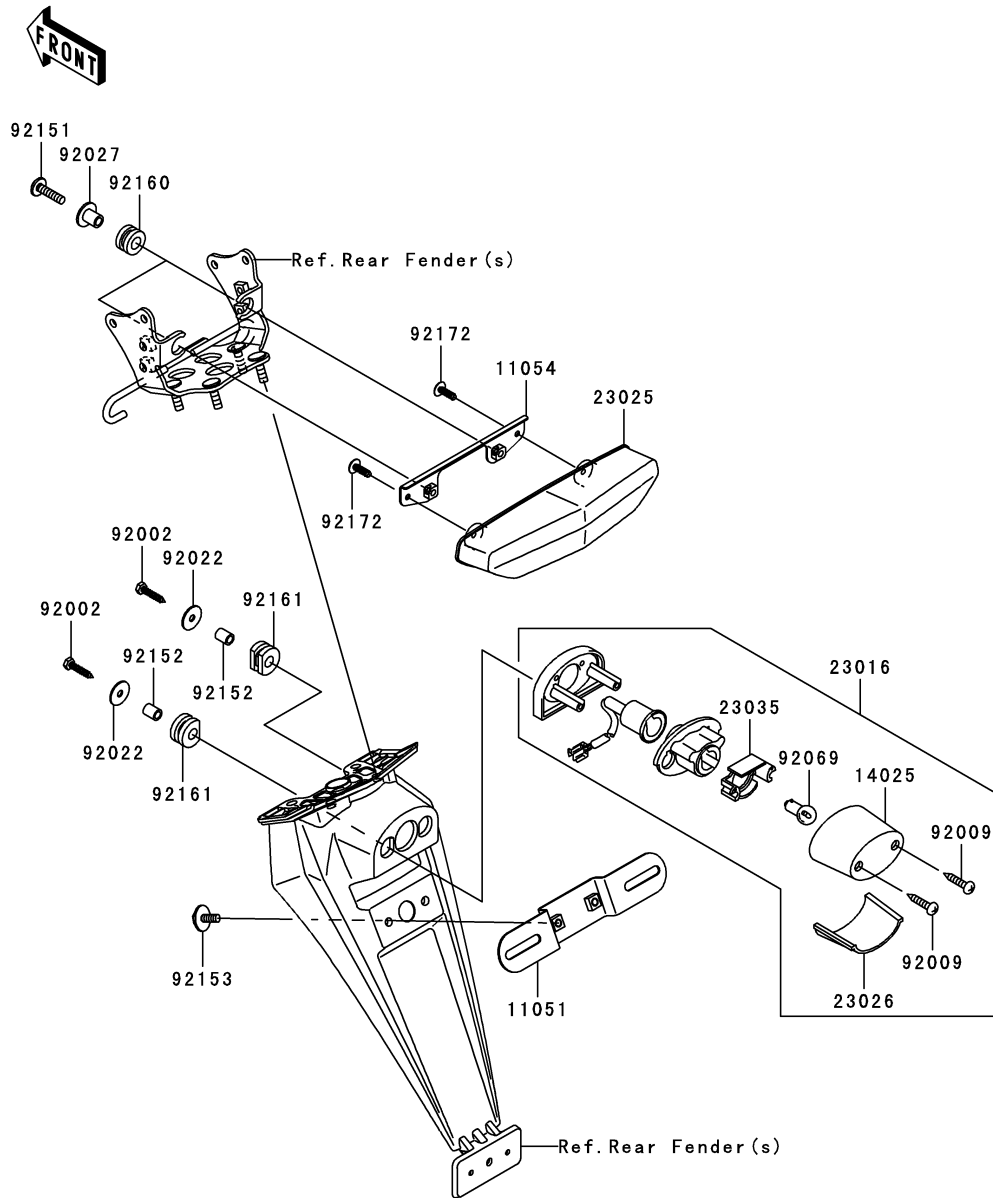

Ref. No.	Part No.	Description	Spec Code	Quantity-ZX600		
				'07	P7F	
11051	11051-1503	BRACKET,LICENSE		1		
11054	11054-0883	BRACKET,TAIL LAMP		1		
14025	14025-1725	COVER,LICENSE LAMP		1		
23016	23016-0014	LAMP-ASSY,LICENSE		1		
23025	23025-0035	LAMP-TAIL		1		
23026	23026-1064	LENS,LICENSE LAMP		1		
23035	23035-1066	REFLECTOR-LAMP,LICENSE		1		
92002	92002-1831	BOLT,TAPPING,5X25		2		
92009	92009-1378	SCREW,TAPPING,4X20		2		
92022	92022-1581	WASHER,5.5X20X1.2		2		
92027	92027-1183	COLLAR		2		
92069	92069-1055	BULB,12V 5W		1		
92151	92151-1611	BOLT,SOCKET,6X25		2		
92152	92152-1458	COLLAR,6X9X11.5		2		
92153	92153-0684	BOLT,6X16		2		
92160	92160-1167	DAMPER		2		
92161	92161-1313	DAMPER		2		
92172	92172-0175	SCREW,TAPPING,5X16		2		

F2730

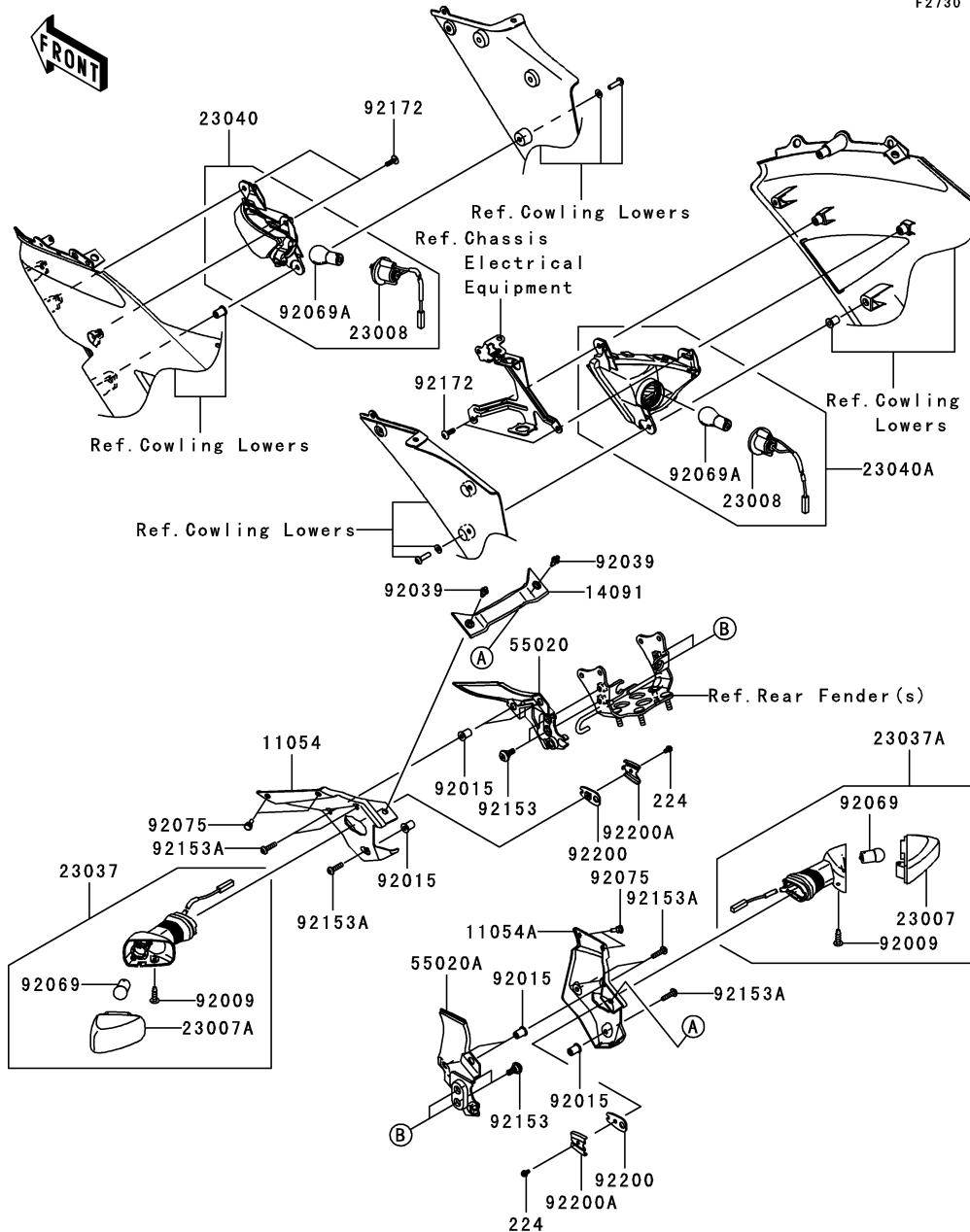

Ref. No.	Part No.	Description	Spec Code	Quantity-ZX600		
				'07		
11054	11054-0888	BRACKET,REAR SIGNAL LAMP,LH				1
11054A	11054-0889	BRACKET,REAR SIGNAL LAMP,RH				1
14091	14091-0685	COVER,REAR SIGNAL LAMP				1
23007	23007-0039	LENS-COMP,SIGNAL LAMP				1
23007A	23007-0040	LENS-COMP,SIGNAL LAMP				1
23008	23008-0044	SOCKET-ASSY,SIGNAL LAMP,FR				2
23037	23037-0113	LAMP-ASSY-SIGNAL,RR,LH				1
23037A	23037-0114	LAMP-ASSY-SIGNAL,RR,RH				1
23040	23040-0059	LAMP-SIGNAL,FR,LH				1
23040A	23040-0060	LAMP-SIGNAL,FR,RH				1
55020	55020-0293	GUARD,HARNESS,LH				1
55020A	55020-0294	GUARD,HARNESS,RH				1
92009	92009-1158	SCREW,4X16,BLACK				2
92015	92015-1757	NUT,WELL,5MM				6
92039	92039-0023	RIVET				2
92069	92069-0003	BULB,12V 10W				2
92069A	92069-1125	BULB,12V 21W				2
92075	92075-1808	DAMPER				4
92153	92153-0489	BOLT,SOCKET,6MM				4
92153A	92153-1244	BOLT,SOCKET,5X16				6
92172	92172-0175	SCREW,TAPPING,5X16				4
92200	92200-0164	WASHER,SIGNAL LAMP				2
92200A	92200-0165	WASHER,SIGNAL LAMP				2
224	224C0408	SCREW-PAN-WP-CROS,4X8				2

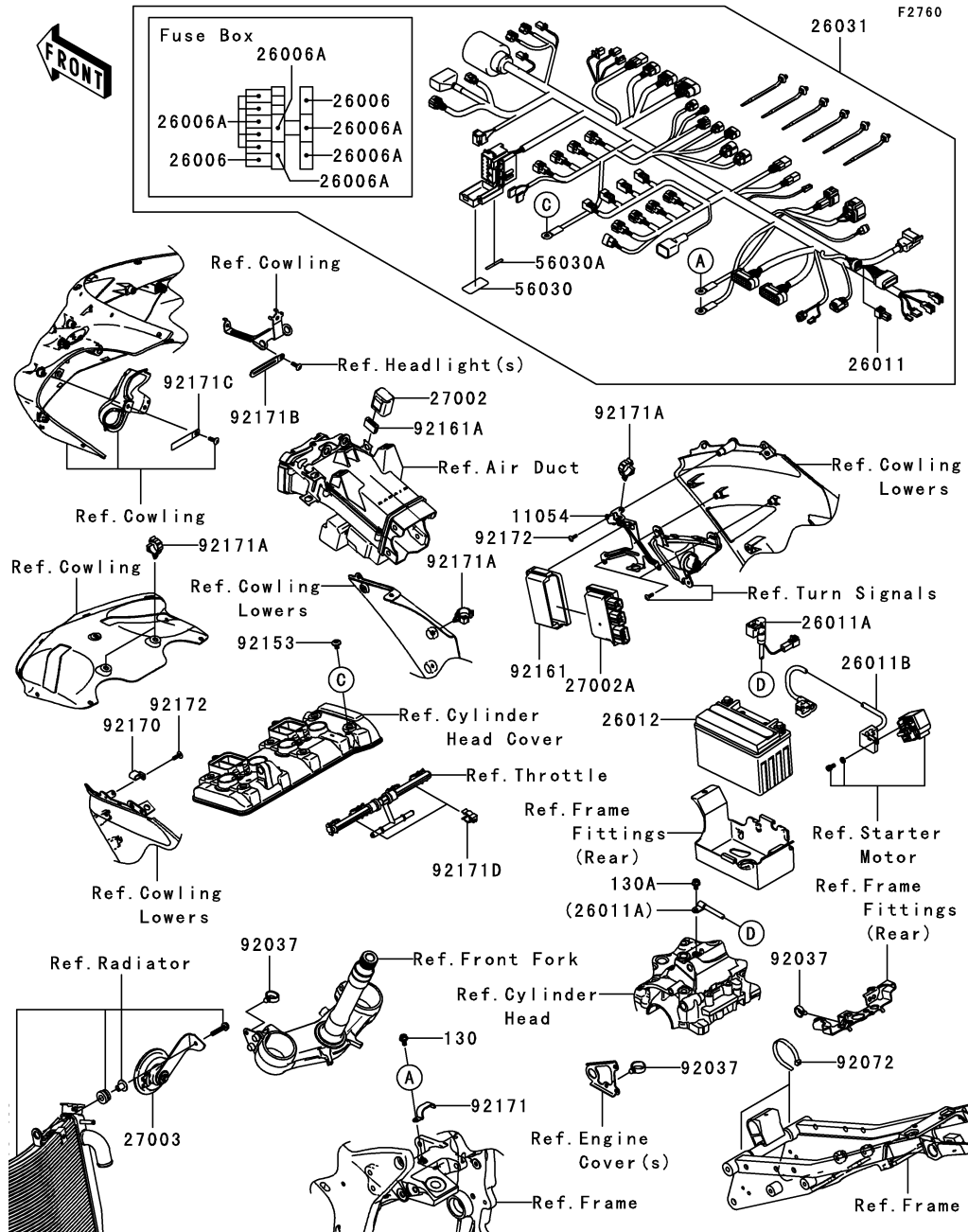

Ref. No.	Part No.	Description	Spec Code	Quantity-ZX600		
				'07		
				P7F		
11054	11054-0865	BRACKET,RELAY BOX				1
26006	26006-0001	FUSE,15A				2
26006A	26006-1078	FUSE,10A				9
26011	26011-0037	WIRE-LEAD				1
26011A	26011-0128	WIRE-LEAD,BATTERY(-)				1
26011B	26011-1764	WIRE-LEAD,BATTERY(+)				1
26012	26012-1326	BATTERY,YTX9-BS,12V 8AH				1
26031	26031-0560	HARNESS,MAIN				1
27002	27002-0005	RELAY-ASSY,SIGNAL LAMP				1
27002A	27002-0007	RELAY-ASSY				1
27003	27003-0030	HORN				1
56030	56030-0046	LABEL,FUSE BOX				1
56030A	56030-0138	LABEL,FUSE BOX				1
92037	92037-1827	CLAMP,HOSE				3
92072	92072-1293	BAND,L=140				2
92153	92153-0410	BOLT,SOCKET,6X10				1
92161	92161-0203	DAMPER,RELAY BOX				1
92161A	92161-0283	DAMPER,SIGNAL RELAY				1
92170	92170-1577	CLAMP				1
92171	92171-0011	CLAMP				1
92171A	92171-0316	CLAMP,BRAKE HOSE				4
92171B	92171-0462	CLAMP				1
92171C	92171-0652	CLAMP				1
92171D	92171-0974	CLAMP				2
92172	92172-0175	SCREW,TAPPING,5X16				2
130	130BA0612	BOLT-FLANGED,6X12				1
130A	130V0610	BOLT-FLANGED,6X10				1

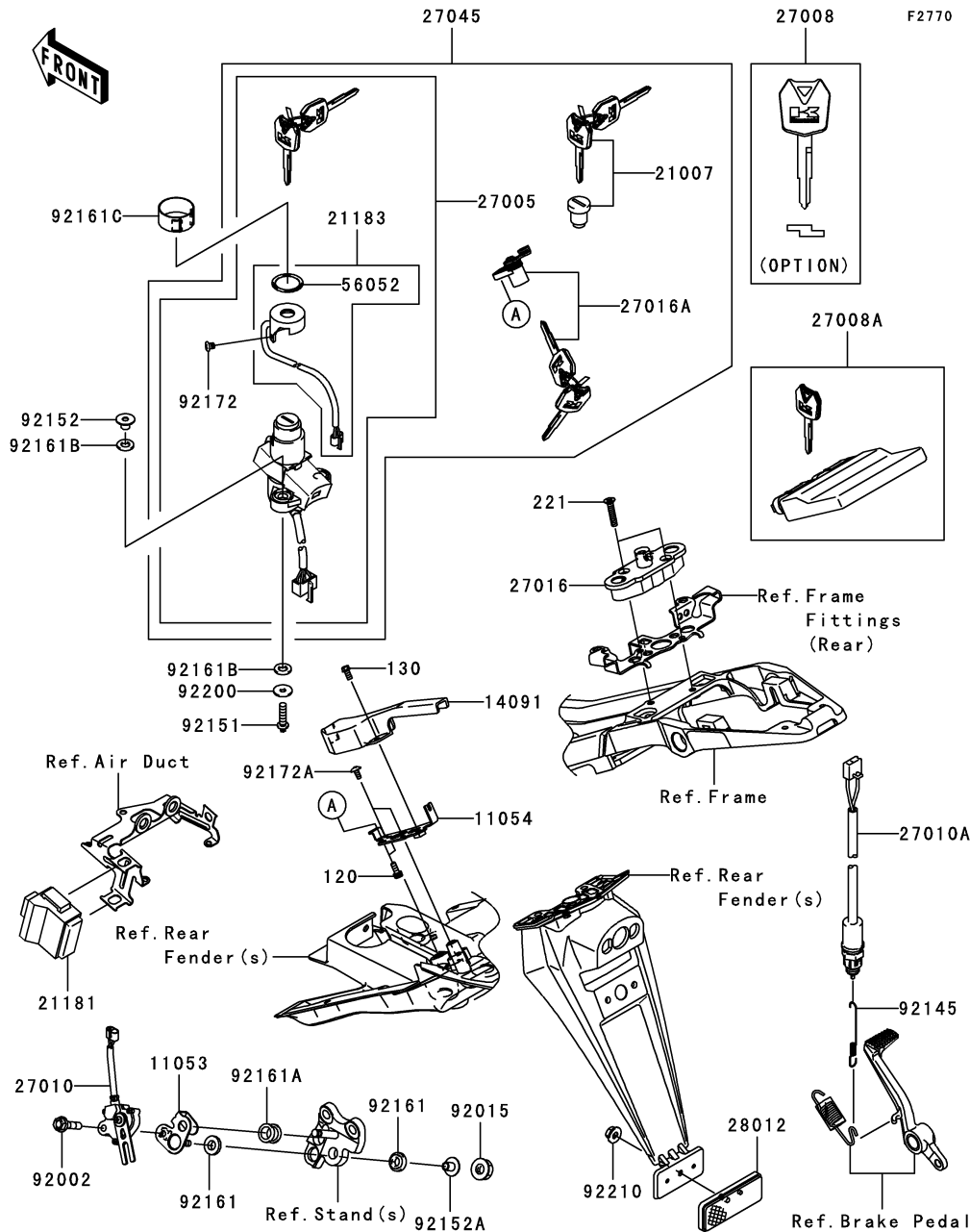

Ref. No.	Part No.	Description	Spec Code	Quantity-ZX600	
				'07	P7F
11053	11053-0723	BRACKET, SIDE STAND SWITCH		1	
11054	11054-0654	BRACKET, SEAT LOCK		1	
14091	14091-0730	COVER, SEAT LOCK		1	
21007	21007-5056	ROTOR, LOCK, TANK CAP		1	
21181	21181-0001	AMPLIFIER, IMMOBI		1	
21183	21183-0002	ANTENNA, IMMOBI		1	
27005	27005-5138	SWITCH-ASSY-IGNITION		1	
27008	27008-0029	KEY-LOCK, BLANK, IMMOBI, SUB (OPTION)		1	
27008A	27008-5030	MASTER KEY SET (BLANK), IMMOBI		1	
27010	27010-1455	SWITCH, SIDE STAND		1	
27010A	27010-1479	SWITCH, REAR BRAKE		1	
27016	27016-0003	LOCK-ASSY, SEAT STRIKER		1	
27016A	27016-5310	LOCK-ASSY, SEAT		1	
27045	27045-5338	SWITCH-ASSY		1	
28012	28012-1077	REFLECTOR-REFLEX		1	
56052	56052-0292	MARK, IMMOBI		1	
92002	92002-1582	BOLT, FLANGED, 6X25		1	
92015	92015-1386	NUT, 6MM		1	
92145	92145-0251	SPRING, REAR BRAKE SWITCH		1	
92151	92151-1946	BOLT, TORX, 6X22		2	
92152	92152-0352	COLLAR		2	
92152A	92152-1074	COLLAR		1	
92161	92161-0117	DAMPER		2	
92161A	92161-0118	DAMPER		1	
92161B	92161-0240	DAMPER, IGNITION SWITCH		4	
92161C	92161-0257	DAMPER, IGNITION SWITCH		1	
92172	92172-0188	SCREW, 4X8		2	
92172A	92172-1061	SCREW, TAPPING, 5X10		2	
92200	92200-0212	WASHER, 6X20X1.6		2	
92210	92210-0007	NUT, FLANGED, 5MM		1	
120	120S0512	BOLT-SOCKET, 5X12		2	
130	130B0510	BOLT-FLANGED, 5X10		1	
221	221F0630	SCREW-CSK-CROSS, 6X30		2	

This catalog covers:

'07 ZX600P7F Chassis

GRID NO.

G-11

This grid covers:

Owner's Tools

F2810

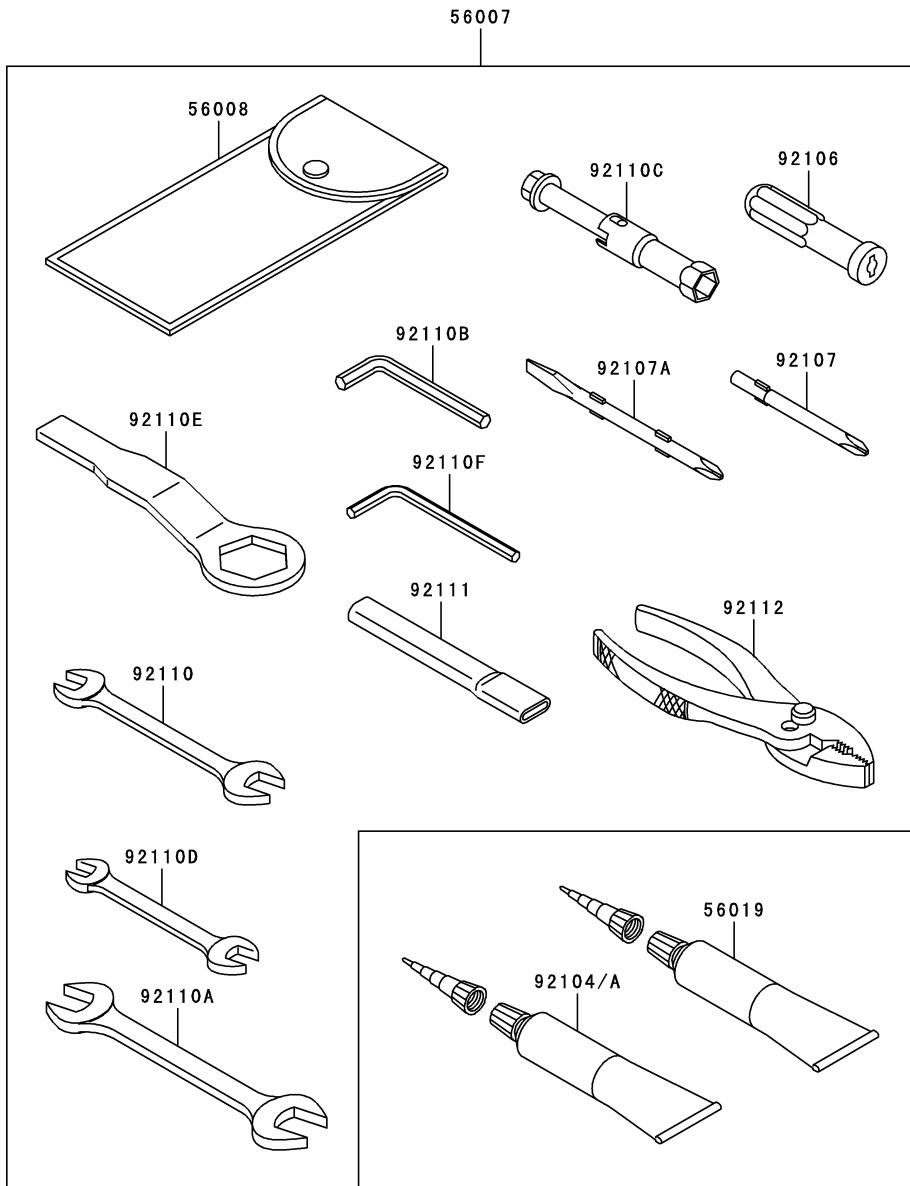

Ref. No.	Part No.	Description	Spec Code	Quantity-ZX600			
				'07			
56007	56007-0033	TOOL-KIT					1
56008	56008-1075	BAG,TOOL					1
56019	56019-120	THREE BOND TB1211,HT/RS,WHITE					1
92104	92104-0004	GASKET-LIQUID,TB1211F					1
92104A	92104-1064	GASKET-LIQUID,BLACK TB1216B					1
92106	92106-1001	GRIP-SCREW DRIVER					1
92107	92107-005	TOOL-DRIVER,#3PHILLIPS					1
92107A	92107-1051	TOOL-DRIVER,#2PHILLIPS&SLOT					1
92110	92110-0019	TOOL-WRENCH,OPEN END,12X14					1
92110A	92110-0020	TOOL-WRENCH,OPEN END,17X19					1
92110B	92110-1015	TOOL-WRENCH,ALLEN,5MM					1
92110C	92110-1132	TOOL-WRENCH,BOX,16MM					1
92110D	92110-1152	TOOL-WRENCH,OPEN END,10X12					1
92110E	92110-1161	TOOL-WRENCH,BOX END,32MM					1
92110F	92110-3703	TOOL-WRENCH,ALLEN,4MM					1
92111	92111-1051	TOOL-BAR,BOX END WRENCH					1
92112	92112-1001	TOOL-PLIERS					1

This catalog covers:

'07 ZX600P7F Chassis

GRID NO.

G-12

This grid covers:

Labels

F2860

Ref. No.	Part No.	Description	Spec Code	Quantity-ZX600			
				'07			
56030	56030-1211	LABEL,GASOLINE					1
56031	56031-1441	LABEL-MANUAL,ENGLISH/FRENCH					1
		L-----FR,WV					
56033	56033-0150	LABEL-MANUAL,DAILY SAFETY					1
56033A	56033-0151	LABEL-MANUAL,CHAIN					1
56053	56053-0202	LABEL-SPECIFICATION,TIRE&LOAD					1
56070	56070-1143	LABEL,UNLEADED PETROL ONLY					1

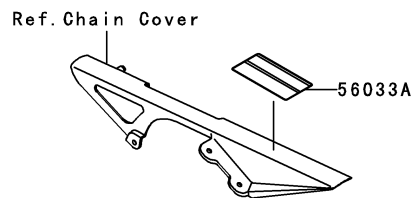
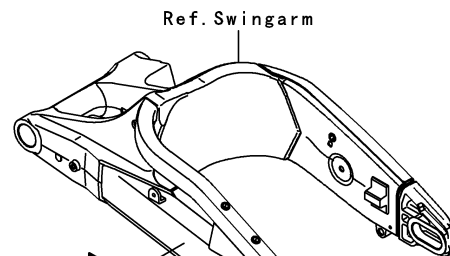
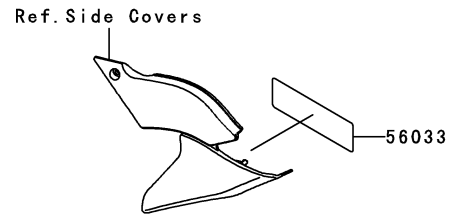
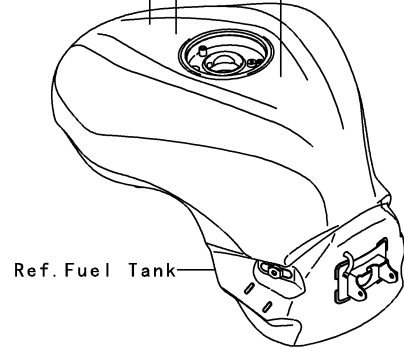
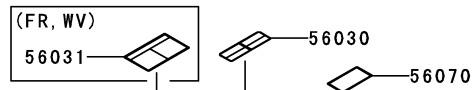

This catalog covers:
'07 ZX600P7F Chassis

GRID NO. **G-13** This grid covers:
Decals(Ebony)

F2861

Ref. No.	Part No.	Description	Spec Code	Quantity-ZX600			
				'07			

56052	56052-0154	MARK,WINDSHIELD,KAWASAKI		1
56054	56054-0001	MARK,FUEL TANK,LH,KAWASAKI		1
56054A	56054-0002	MARK,FUEL TANK,RH,KAWASAKI		1
56054B	56054-0004	MARK,SEAT COVER,ZX-6R		2
56054C	56054-0008	MARK,CNT COWLING,NINJA		2

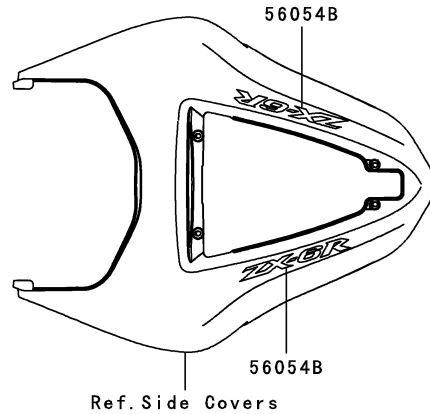
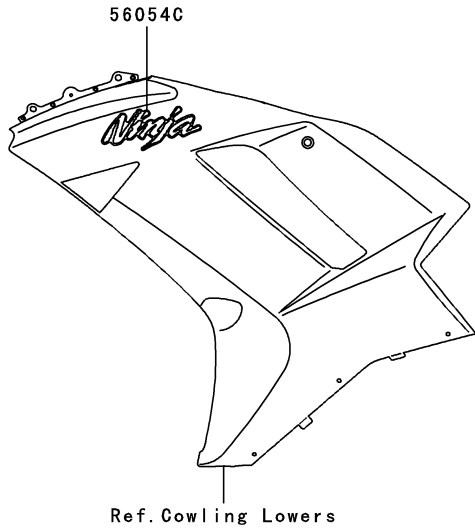
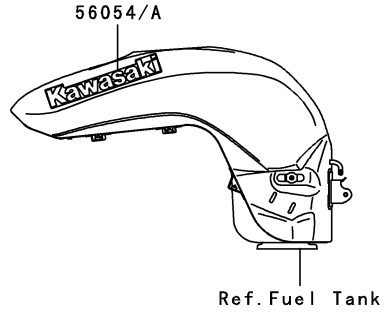
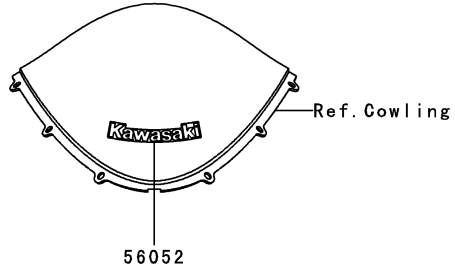

This catalog covers:

'07 ZX600P7F Chassis

GRID NO.

G-14

This grid covers:

Decals(Green)

F2861A

Ref. No.	Part No.	Description	Spec Code	Quantity-ZX600			
				'07			

56052	56052-0154	MARK,WINDSHIELD,KAWASAKI		1			
56052A	56052-1997	MARK,FUEL TANK,LH,KAWASAKI		1			
56052B	56052-1998	MARK,FUEL TANK,RH,KAWASAKI		1			
56054	56054-0003	MARK,SEAT COVER,ZX-6R		2			
56054A	56054-0007	MARK,CNT COWLING,NINJA		2			
56054B	56054-0009	MARK,UPP COWLING		1			
56054C	56054-0040	MARK,FUEL TANK,LH		1			
56054D	56054-0041	MARK,FUEL TANK,RH		1			

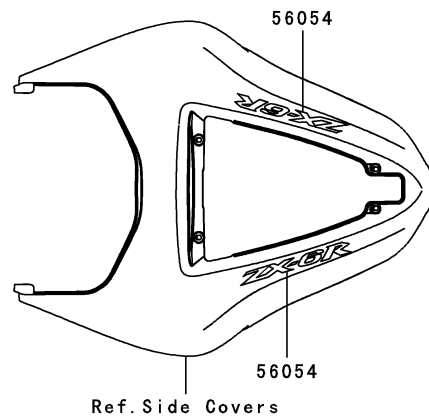
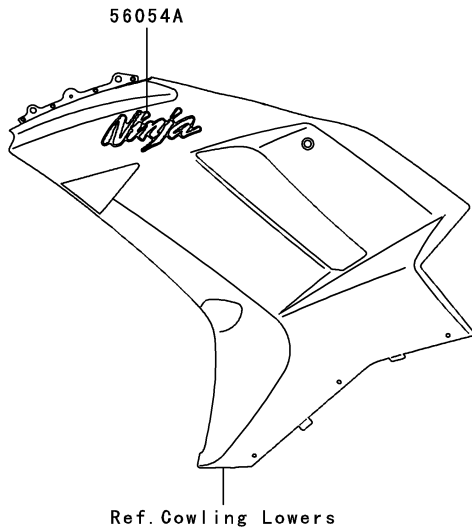
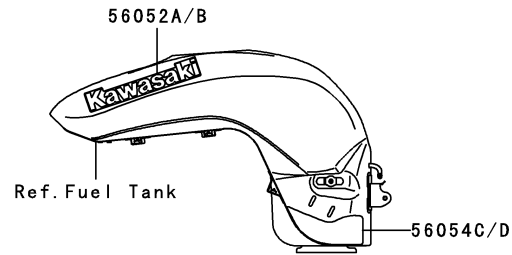
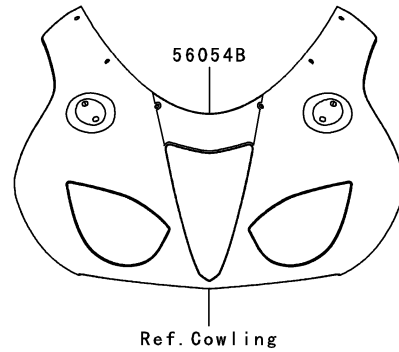
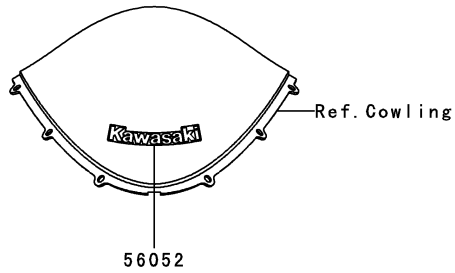

This catalog covers:
'07 ZX600P7F Chassis

GRID NO. **H-3** This grid covers:
Decals(Orange)

F2861B

Ref. No.	Part No.	Description	Spec Code	Quantity-ZX600			
				'07			

56052	56052-0154	MARK,WINDSHIELD,KAWASAKI		1
56052A	56052-1997	MARK,FUEL TANK,LH,KAWASAKI		1
56052B	56052-1998	MARK,FUEL TANK,RH,KAWASAKI		1
56054	56054-0003	MARK,SEAT COVER,ZX-6R		2
56054A	56054-0007	MARK,CNT COWLING,NINJA		2
56054B	56054-0040	MARK,FUEL TANK,LH		1
56054C	56054-0041	MARK,FUEL TANK,RH		1

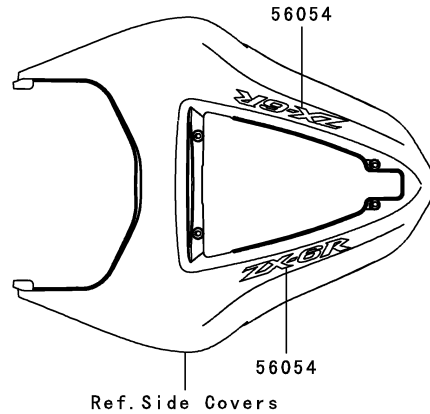
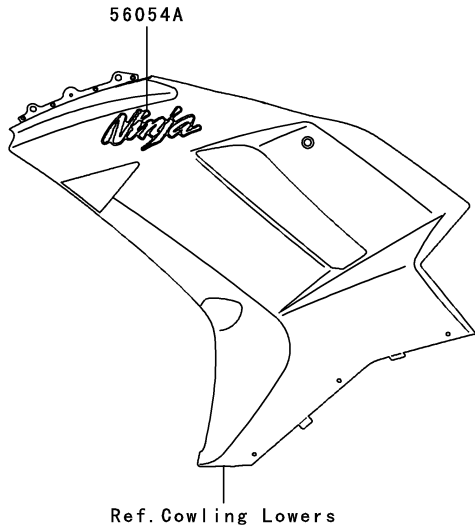
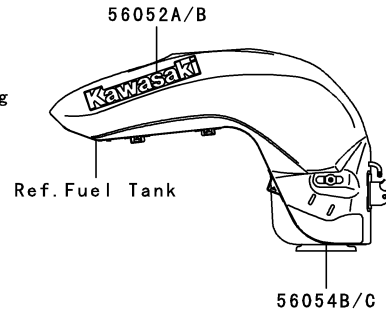
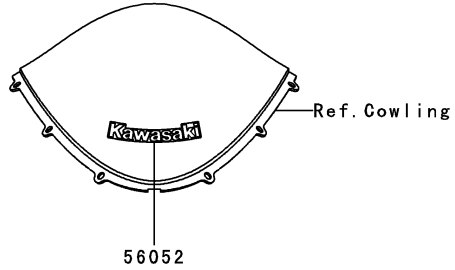

This catalog covers:
'07 ZX600P7F Chassis

GRID NO. **H-5** This grid covers:
Cowling Lower

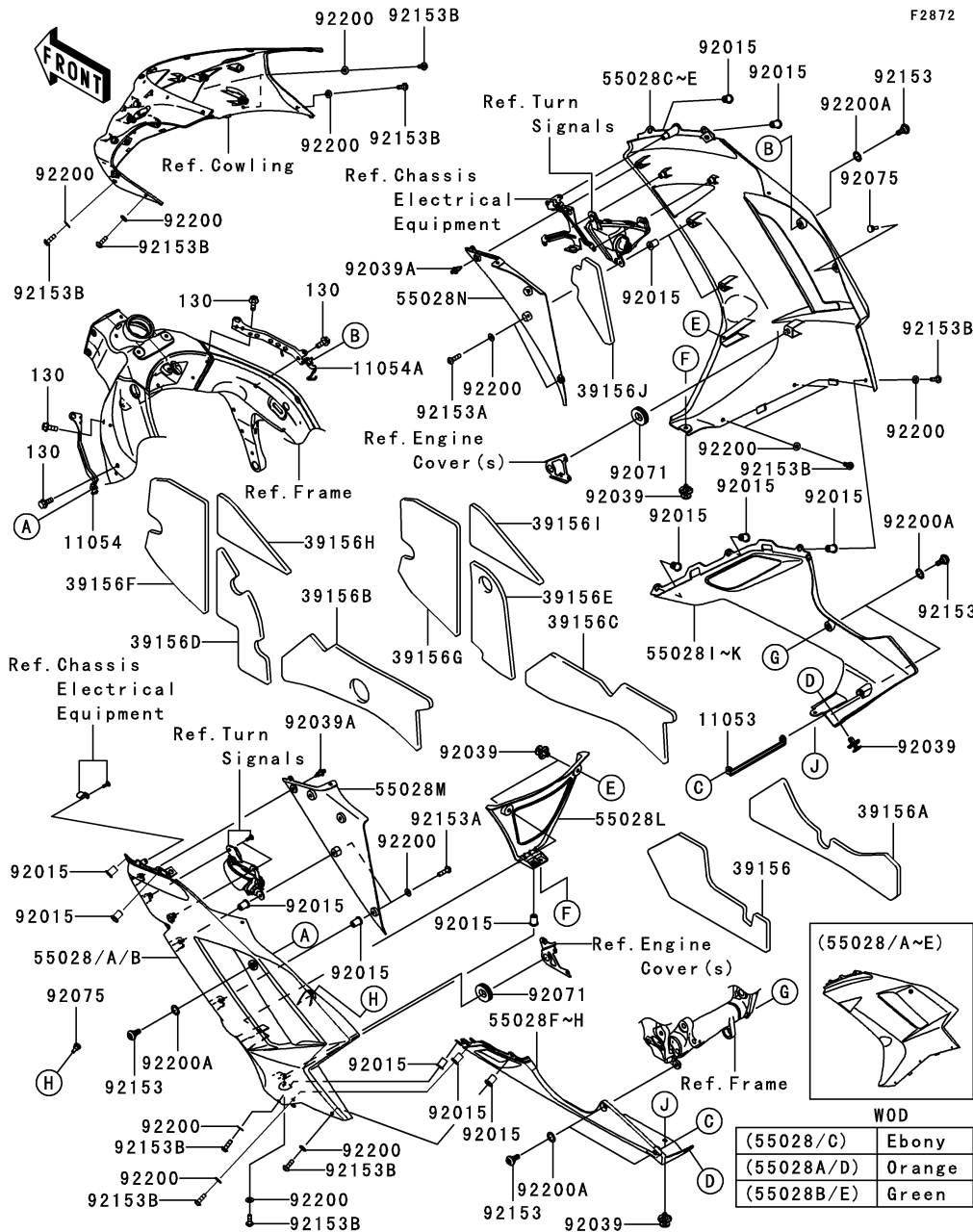

F2872

Ref. No.	Part No.	Description	Spec Code	Quantity-ZX600		
				'07	P7F	
11053	11053-0402	BRACKET,LWR COWLING			1	
11054	11054-0656	BRACKET,CNT COWLING,LH			1	
11054A	11054-0657	BRACKET,CNT COWLING,RH			1	
39156	39156-0224	PAD,LWR COWLING,LH			1	
39156A	39156-0225	PAD,LWR COWLING,RH			1	
39156B	39156-0226	PAD,CNT COWLING,LWR,LH			1	
39156C	39156-0227	PAD,CNT COWLING,LWR,RH			1	
39156D	39156-0228	PAD,CNT COWLING,RR,LH			1	
39156E	39156-0229	PAD,CNT COWLING,RR,RH			1	
39156F	39156-0230	PAD,CNT COWLING,FR,LH			1	
39156G	39156-0231	PAD,CNT COWLING,FR,RH			1	
39156H	39156-0232	PAD,CNT COWLING,UPP,LH			1	
39156I	39156-0233	PAD,CNT COWLING,UPP,RH			1	
39156J	39156-0274	PAD,FR COWLING,RH			1	
55028	55028-0127-H8	COWLING,CNT,LH,EBONY			1	
55028A	55028-0127-17H	COWLING,CNT,LH,P.ORANGE			1	
55028B	55028-0127-777	COWLING,CNT,LH,L.GREEN			1	
55028C	55028-0128-H8	COWLING,CNT,RH,EBONY			1	
55028D	55028-0128-17H	COWLING,CNT,RH,P.ORANGE			1	
55028E	55028-0128-777	COWLING,CNT,RH,L.GREEN			1	
55028F	55028-0129-H8	COWLING,LWR,LH,EBONY			1	
55028G	55028-0129-18T	COWLING,LWR,LH,BLACK			1	
55028H	55028-0129-777	COWLING,LWR,LH,L.GREEN			1	
55028I	55028-0130-H8	COWLING,LWR,RH,EBONY			1	
55028J	55028-0130-18T	COWLING,LWR,RH,BLACK			1	
55028K	55028-0130-777	COWLING,LWR,RH,L.GREEN			1	
55028L	55028-0131	COWLING,FR			1	
55028M	55028-0133	COWLING,FR,LH			1	
55028N	55028-0134	COWLING,FR,RH			1	
92015	92015-1757	NUT,WELL,5MM			15	
92039	92039-0014	RIVET			5	
92039A	92039-0023	RIVET			2	
92071	92071-1043	GROMMET			2	
92075	92075-1808	DAMPER			2	
92153	92153-0489	BOLT,SOCKET,6MM			6	
92153A	92153-0873	BOLT,SOCKET,5X20			4	
92153B	92153-1244	BOLT,SOCKET,5X16			11	
92200	92200-0006	WASHER,NYLONE,5.3X11.5X0.5			15	
92200A	92200-0157	WASHER,10.4X15.9X0.5			6	
130	130L0616	BOLT-FLANGED,6X16			4	

This catalog covers:
'07 ZX600P7F

GRID NO.

L-12

This grid covers:

Numerical Parts Index

Part No.	Grid No.	Part No.	Grid No.	Part No.	Grid No.	Part No.	Grid No.	Part No.	Grid No.	Part No.	Grid No.
11004-0057	B-3	11061-0029	F-7	13087-0020	B-12	13159-1061	F-6	14091-0613	B-4	21176-1120	C-11
11008-0095	B-3	11061-0107	C-12	13088-0003	B-12	13161-0054	C-3	14091-0620	C-6	21176-2106	C-11
11009-1145	D-6	11061-0242	B-5	13088-0025	B-12	13183-1460	D-3	14091-0685	G-8	21181-0001	G-10
11010-0134	B-5	11061-0243	B-5	13089-0008	B-12	13187-0011	B-12	14091-0711	F-14	21183-0002	G-10
11012-1084	D-6	11061-0244	B-5	13089-0009	B-12	13194-3705	D-3	14091-0730	G-10	220C0525	F-10
11012-1283	F-5	11061-0245	B-5	13089-1093	B-12	13236-0103	F-6	14091-0792	B-7	220C0535	F-10
11013-0016	B-5	11061-0246	B-4	13091-1041	B-12	13236-0114	C-3	14091-0795	E-11	220C0545	F-10
11051-1503	G-7	11061-0247	B-4	13091-1624	F-10	13236-0122	C-3	14091-0799	D-4	221F0630	G-10
11053-0386	F-13	11061-0249	C-6	13095-0063	B-12	13236-0135	F-4	14091-0802	C-6	224C0408	G-8
11053-0402	H-5	11061-0250	C-6	130B0510	G-10	13239-0024	B-14	150R0510	D-3	225F0412	F-8
11053-0723	G-10	11061-0251	C-6	130BA0510	F-12	13242-0029	C-3	16007-0003	B-8	23007-0039	G-8
11053-1289	H-4	11061-0252	C-6	130BA0610	E-11	13251-0018-JJ	B-11	16007-1227	B-8	23007-0040	G-8
11053-1545	F-6	11061-0253	C-7	130BA0610	E-6	13262-0372	B-13	16014-0002	C-8	23007-0071	G-6
11053-1691	E-7	11061-0262	C-6	130BA0612	G-4	13262-0374	B-13	16021-0014	C-8	23008-0044	G-8
11054-0579	C-6	11061-0291	C-4	130BA0612	G-9	13262-0375	B-13	16065-0035	B-3	23008-0065	G-6
11054-0654	G-10	11065-0009	F-5	130BA0616	F-13	13262-0380	B-13	16073-0010	C-9	23016-0012	G-6
11054-0656	H-5	11065-0018	C-8	130BA0625	G-6	13262-0381	B-13	16073-3707	C-8	23016-0014	G-7
11054-0657	H-5	11065-0095	E-5	130BA0835	E-4	13262-0506	B-13	16085-0101	D-3	23025-0035	G-7
11054-0753	B-6	11065-0157	B-4	130CD0835	B-7	13262-0507	B-13	16097-0004	C-12	23026-1064	G-7
11054-0755	F-8	11065-0184-KX	F-11	130J0514	C-9	13262-0508	B-13	16115-1009	C-6	23035-1066	G-7
11054-0761	C-13	12004-0022	B-8	130L0512	C-14	13262-0509	B-13	16126-0031	F-11	23037-0113	G-8
11054-0817	C-11	12005-0041	B-8	130L0514	D-6	13262-0510	B-13	16126-1140	E-13	23037-0114	G-8
11054-0818	B-4	12009-0013	B-8	130L0518	B-7	13271-0559	C-8	16126-1437	B-5	23040-0059	G-8
11054-0864	D-6	12009-0014	B-8	130L0520	F-6	13271-0795	C-4	16130-1059	C-12	23040-0060	G-8
11054-0865	G-9	12011-1052	B-8	130L0610	F-12	13280-0109	D-3	16142-0041	C-12	236C0410	F-10
11054-0880	F-11	12021-0016	B-4	130L0616	F-8	13280-0199	C-4	16142-0050	C-12	25023-0029	F-14
11054-0883	G-7	12032-0008	B-8	130L0616	H-4	13280-1160	F-10	16146-0041	F-12	25031-0133	F-14
11054-0888	G-8	12032-0009	B-8	130L0616	H-5	132BA0608	E-6	16146-0042	F-12	26006-0001	G-9
11054-0889	G-8	12046-0053	B-10	130L0625	C-13	132BA0610	E-6	16154-0057	C-12	26006-1006	D-3
11054-0929	H-4	12048-1181	B-10	130L0630	B-5	132BA0614	E-6	16160-0140	C-12	26006-1078	G-9
11054-0930	H-4	12053-0084	B-10	130L0670	F-12	132BA0616	E-11	16163-0085	C-8	26011-0037	G-9
11054-1175	D-3	12053-0085	B-10	130V0610	G-9	132BA0616	E-6	16163-0089	C-8	26011-0118	D-3
11054-1212	C-6	12053-0086	B-10	130W0630	D-4	132J0612	F-6	16181-0011	B-6	26011-0128	G-9
11054-1421	E-6	12053-0109	C-6	130Y0610	C-12	132L0612	C-12	18091-0329	B-7	26011-1764	G-9
11054-1439	G-4	120CA0610	F-13	130Y0610	C-4	132L0620	D-6	180L0614	F-4	26012-1326	G-9
11054-1477	E-6	120P0620	F-10	13102-0032	B-12	14001-0112	C-4	186L0514	E-10	26031-0560	G-9
11054-1480	E-6	120Q0620	B-12	13107-0131	C-12	14013-1051	C-4	21003-0049	C-13	27002-0005	G-9
11054-1483	E-6	120S0510	D-3	13107-0132	C-12	14014-0019	C-4	21007-0091	C-13	27002-0007	G-9
11054-1519	E-6	120S0512	G-10	13107-0157	B-10	14014-0029	C-4	21007-5056	G-10	27003-0030	G-9
11054-1643	C-6	120W0522	C-11	13107-0168	D-3	14014-0030	C-4	21066-0025	C-13	27005-5138	G-10
11054-1770	E-6	120W0820	F-9	13107-0174	D-3	14025-1725	G-7	21163-0041	D-3	27008-0029	G-10
11054-1773	E-11	120Z0630	B-3	13127-0044	B-13	14026-0040-11E	C-6	21171-1282	C-14	27008-5030	G-10
11054-1840	B-14	13001-0081	B-11	13128-0031	B-13	14031-0082-11E	C-6	21174-0003	B-7	27010-0025	F-6
11054-1841	E-6	13002-0015	B-11	13140-0041	B-14	14032-0088-11E	C-6	21175-0109	C-11	27010-0030	D-3
11054-1910	C-6	13008-0023	B-11	13140-0042	B-14	14037-0057	B-6	21176-0026	C-11	27010-1313	C-4
11054-1942	F-13	13031-0075	B-11	13140-0048	B-14	14073-0134-21	H-4	21176-0034	C-11	27010-1455	G-10
11055-0002	F-11	13042-1133	F-10	13144-0038	B-13	14073-0151	B-5	21176-0045	C-6	27010-1479	G-10
11060-1180	F-11	13045-1057	B-5	13145-0029	B-14	14073-0152	B-5	21176-0058	C-11	27010-1492	F-10
11060-1203	B-7	13070-0045	F-9	13151-0023	B-14	14091-0103-6Z	E-10	21176-0073	C-11	27012-0091	F-12
11060-1330	B-7	13087-0019	B-12	13159-1056	F-8	14091-0104-6Z	E-10	21176-0086	C-11	27012-0115	F-12

This catalog covers:
'07 ZX600P7F

GRID NO.

L-13

This grid covers:

Numerical Parts Index

Part No.	Grid No.	Part No.	Grid No.	Part No.	Grid No.	Part No.	Grid No.	Part No.	Grid No.	Part No.	Grid No.
27016-0003	G-10	39062-0154	D-6	41068-0034	E-14	43084-003	F-9	49063-1055	C-12	55028-0128-H8	H-5
27016-5310	G-10	39062-0155	D-6	41068-0035	F-3	43095-0289	F-8	49065-0016	C-12	55028-0129-18T	H-5
27045-5338	G-10	39062-0156	D-6	41073-0106-18F	F-3	43095-0303	F-6	49078-0052	B-8	55028-0129-777	H-5
28011-0074	F-14	39062-0159	D-6	41073-0107-18F	E-14	43095-0315	F-8	49078-0063	B-8	55028-0129-H8	H-5
28012-1077	G-10	39062-0166	D-6	41075-0007	E-13	43095-0356	F-6	49085-1066	D-4	55028-0130-18T	H-5
31064-0023	C-8	39062-0197	D-5	41075-0008	E-13	44008-0028-KX	F-11	49091-0001	F-6	55028-0130-777	H-5
318G0800	E-7	39062-0198	D-5	41075-0009	E-13	44013-0071-18R	F-11	49091-0001	F-8	55028-0130-H8	H-5
32033-1535	C-12	39062-1493	D-6	41080-0040	F-9	44013-0072-18R	F-11	49106-0055	B-7	55028-0131	H-5
32037-1887	E-5	39062-1814	D-6	41080-0077-5C	F-7	44023-0051	F-11	49106-0056	B-7	55028-0132	H-4
32043-0043-18R	E-12	39067-0014	D-5	42033-0026	F-3	44026-0100	F-11	49106-0058	B-7	55028-0133	H-5
32052-0069-18R	F-12	39111-0018	E-8	42036-1258	E-8	44037-0074	F-11	49106-0059	B-7	55028-0134	H-5
32054-0034	E-6	39111-0039	C-3	42036-1279	F-3	44039-0068-829	F-11	49118-0103	B-10	55028-0135	H-4
32054-0035	E-6	39130-1078	B-12	42036-1283	E-7	44065-0001	F-11	49118-0104	B-10	55028-0136	H-4
32085-0047	E-9	39130-1079	B-12	42036-1342	E-8	44065-0002	F-11	51044-0032	C-10	550D2015	F-8
32097-0025	E-6	39154-0016	H-4	42036-1360	E-8	44071-5038	F-11	51044-0033	C-9	550D4040	F-3
32099-0026	D-3	39156-0224	H-5	42041-0017	F-3	44071-5039	F-11	51049-0014	F-12	550S3025	E-5
32099-0035	C-12	39156-0225	H-5	43010-1062	F-8	45014-0181-23A	F-5	51085-5141-17H	F-12	551A0408	C-12
32099-1193	F-10	39156-0226	H-5	43015-0096	F-8	46003-0136	F-10	51085-5141-777	F-12	555A0316	D-3
32160-0250-18R	E-3	39156-0227	H-5	43015-0097	F-6	46003-0137	F-10	51085-5144-H8	F-12	56001-0084	H-4
32160-0258	E-3	39156-0228	H-5	43020-0003	F-6	46019-0001	F-10	52005-0024	C-6	56001-0085	H-4
32190-0327	E-4	39156-0229	H-5	43020-1094	F-8	46075-1144	F-10	53003-0098-MA	F-13	56007-0033	G-11
33001-0126-18R	E-7	39156-0230	H-5	43026-0009	F-8	46076-0033	F-10	53003-0099-MA	F-13	56008-1075	G-11
33032-0010	E-7	39156-0231	H-5	43026-1051	F-6	46091-0114	F-10	53044-1198	E-11	56019-120	G-11
33040-1114	E-7	39156-0232	H-5	43027-1051	F-6	46091-0115	F-10	53044-1284	E-11	56030-0046	G-9
33040-1180	E-7	39156-0233	H-5	43027-1053	F-8	46092-0006	F-10	53065-0010-17H	F-13	56030-0138	G-9
34024-0001-18R	E-12	39156-0236	G-4	43028-1057	F-6	46102-0090	B-12	53065-0010-777	F-13	56030-1211	G-12
34028-0029	E-9	39156-0237	G-4	43028-1065	F-8	461K0500	D-3	53065-0010-H8	F-13	56031-1441	G-12
34028-0030	E-9	39156-0240	H-4	43034-0008	F-9	480J1100	C-12	53066-0178-MA	F-13	56033-0150	G-12
34028-1480	E-9	39156-0241	H-4	43034-1016	F-6	480J1400	C-3	53066-0187-12Y	F-13	56033-0151	G-12
34028-1481	E-9	39156-0243	G-4	43044-0002	F-9	481J5500	F-3	54010-0055	G-3	56052-0154	G-13
35004-0076-17H	E-10	39156-0244	G-4	43048-0003	F-9	482L0100	E-9	54010-0072	B-7	56052-0154	G-14
35004-0076-777	E-10	39156-0245	G-4	43048-0005	F-7	482L5000	E-9	54010-0073	B-7	56052-0154	H-3
35004-0076-H8	E-10	39156-0247	D-6	43049-0006	F-7	49002-1152	B-3	54011-0076	G-3	56052-0292	G-10
35019-0061	E-11	39156-0252	F-12	43049-0007	F-7	49006-1054	F-9	54012-0194	G-3	56052-1997	G-14
35023-0115	E-11	39156-0258	D-6	43049-1097	F-9	49006-1095	F-9	55020-0111	E-7	56052-1997	H-3
35034-0053-18R	E-7	39156-0259	D-6	43056-1054	F-9	49006-1212	F-9	55020-0134	E-5	56052-1998	G-14
35063-0144-W9	E-6	39156-0260	G-4	43056-1055	F-7	49016-0023	G-6	55020-0268	E-5	56052-1998	H-3
35063-0145-W9	E-6	39156-0261	E-11	43056-1056	F-6	49016-0042	D-4	55020-0293	G-8	56053-0202	G-12
35063-0160-W9	E-5	39156-0261	G-4	43057-003	F-9	49016-1147	F-6	55020-0294	G-8	56054-0001	G-13
35063-0329	D-4	39156-0271	F-12	43057-1001	F-6	49033-0013	C-8	55020-0358	C-12	56054-0002	G-13
35063-0419-W9	E-5	39156-0272	F-12	43057-1001	F-7	49033-0015	C-9	55022-0033	H-4	56054-0003	G-14
36001-0103	G-4	39156-0274	H-5	43059-1696	F-6	49034-0019	C-7	55022-0034	H-4	56054-0003	H-3
36001-0121	G-4	39156-0276	B-7	43078-0037	D-6	49040-0023	C-10	55028-0126-17H	H-4	56054-0004	G-13
36014-0020	G-5	39156-0277	D-6	43078-0040	F-8	49047-0026	B-14	55028-0126-777	H-4	56054-0007	G-14
36040-0054-17H	G-4	39156-0278	B-7	43078-1099	F-6	49047-0027	B-14	55028-0126-H8	H-4	56054-0007	H-3
36040-0054-777	G-4	39156-0279	B-7	43080-0014-DJ	F-9	49054-1067	D-6	55028-0127-17H	H-5	56054-0008	G-13
36040-0054-H8	G-4	39178-0068	B-7	43080-0046-DJ	F-7	49056-0014	C-8	55028-0127-777	H-5	56054-0009	G-14
39007-0006	E-8	39192-0058	D-6	43080-0047-DJ	F-7	49056-0015	C-9	55028-0127-H8	H-5	56054-0040	G-14
39045-0019	B-6	41009-0139	E-13	43082-0068	F-9	49056-0016	C-9	55028-0128-17H	H-5	56054-0040	H-3
39061-0092	D-4	41009-0162	E-13	43082-0072	F-7	49062-0033	B-7	55028-0128-777	H-5	56054-0041	G-14

This catalog covers:
'07 ZX600P7F

GRID NO.

L-14

This grid covers:

Numerical Parts Index

Part No.	Grid No.	Part No.	Grid No.	Part No.	Grid No.	Part No.	Grid No.	Part No.	Grid No.	Part No.	Grid No.
56054-0041	H-3	92015-1487	D-4	92037-1827	C-6	92049-1225	E-8	92066-1012	C-4	92139-0038	B-13
56070-1143	G-12	92015-1603	E-11	92037-1827	D-6	92049-1308	B-8	92066-1110	C-4	92139-0067	B-12
59026-0026	C-14	92015-1700	E-6	92037-1827	F-6	92049-1314	E-7	92066-1161	C-4	92139-0161	B-13
59051-0067	C-12	92015-1757	E-11	92037-1827	G-9	92049-1336	C-12	92066-1174	C-7	92139-0162	B-13
59051-0068	D-3	92015-1757	G-4	92037-1903	C-13	92049-1375	F-3	92069-0003	G-8	92139-0163	B-13
59051-0069	D-3	92015-1757	G-8	92039-0014	H-5	92049-1376	F-3	92069-0007	G-6	92139-0164	B-13
59071-0034	C-9	92015-1757	H-4	92039-0023	E-11	92049-1377	E-14	92069-0014	G-6	92139-0165	B-11
59071-3752	C-8	92015-1757	H-5	92039-0023	G-8	92049-1382	E-3	92069-1016	G-6	92139-0166	B-11
59091-0007	B-7	92015-1791	E-3	92039-0023	H-4	92049-1448	F-7	92069-1055	G-7	92139-0167	B-11
59256-1074	C-12	92015-1792	E-3	92039-0023	H-5	92049-1474	C-4	92069-1125	G-8	92139-0171	B-11
59478-0004	C-9	92015-1844	F-3	92039-0065	D-4	92049-1475	C-6	92070-1266	C-14	92139-0172	B-11
59502-0027	D-4	92015-1881	E-5	92042-007	B-3	92049-1493	E-8	92071-0011	B-7	92139-0173	B-11
600A0500	B-13	92022-077	C-12	92042-007	C-6	92049-1520	C-4	92071-0020	G-5	92139-0189	B-11
600A0800	E-9	92022-1093	G-4	92042-030	C-12	92055-0002	F-5	92071-0031	D-3	92139-0190	B-11
601B6005UU	E-14	92022-1282	F-4	92042-044	C-6	92055-0013	D-3	92071-0033	C-11	92139-0191	B-11
601B6006G	F-3	92022-1346	F-8	92043-0028	E-9	92055-0074	B-3	92071-1043	H-5	92143-1353	G-6
601B6205UU	F-3	92022-1405	F-14	92043-0104	F-8	92055-0077	C-9	92071-3704	B-6	92143-1595	C-3
610A0406	B-14	92022-1581	G-7	92043-0105	F-7	92055-0079	C-9	92072-0078	E-6	92143-1962	D-6
670D1509	B-10	92022-1601	F-8	92043-0114	B-10	92055-0126	D-3	92072-1195	F-10	92144-1423	D-3
670D2018	C-12	92022-2373	E-11	92043-1262	C-12	92055-0133	B-3	92072-1293	G-9	92144-1451	C-8
670D2018	C-4	92022-304	C-12	92043-1263	C-12	92055-0142	F-11	92072-1338	E-6	92144-1719	F-9
670E5075	C-10	92022-304	C-4	92043-1263	C-6	92055-049	C-6	92075-1011	H-4	92144-1818	E-12
671B2560	F-3	92022-326	F-4	92043-1263	C-7	92055-086	B-10	92075-1123	D-4	92144-1854	B-12
671B2565	D-5	92022-3730	B-7	92043-1264	B-3	92055-091	B-14	92075-1123	F-12	92145-0230	F-4
702A06850	F-12	92026-0022	B-12	92043-1489	F-9	92055-091	C-4	92075-1446	F-13	92145-0251	G-10
92001-1342	D-6	92026-0107	C-3	92043-1506	C-4	92055-1141	C-6	92075-161	F-6	92145-0294	C-8
92002-1154	C-12	92026-0108	E-4	92043-1567	C-4	92055-1251	F-6	92075-1634	D-6	92145-0376	E-9
92002-1323	F-6	92026-1276	F-11	92043-1595	E-9	92055-1251	F-8	92075-1808	F-13	92145-0414	C-3
92002-1582	G-10	92026-1356	B-12	92043-1654	B-14	92055-1293	B-13	92075-1808	G-8	92145-0415	C-3
92002-1796	C-6	92026-1529	B-13	92043-4009	B-4	92055-1352	B-4	92075-1808	H-5	92145-0416	C-3
92002-1831	G-7	92026-1534	C-3	92045-0003	B-13	92055-1402	D-6	92075-1912	C-11	92145-0436	F-7
92004-0025	B-3	92026-1586	E-5	92045-0017	E-7	92055-1455	D-3	92075-209	E-11	92145-0485	B-12
92004-1275	F-3	92026-1594	E-5	92045-0058	B-13	92055-1503	C-12	92092-1075	F-10	92145-0486	B-12
92005-0070	D-6	92027-1183	G-7	92045-1045	B-14	92055-1532	C-12	92093-0034	E-5	92145-0510	C-8
92005-0071	B-4	92033-0034	F-6	92045-1152	B-14	92055-1536	B-3	92093-0035	F-11	92145-1159	B-12
92005-0076	D-6	92033-0047	B-13	92045-1384	E-3	92055-1622	C-8	92093-0068	B-6	92145-1286	F-10
92005-1238	C-4	92033-025	B-13	92046-0004	D-3	92055-1699	D-6	92104-0004	G-11	92145-1319	E-9
92005-1273	B-3	92033-1037	B-13	92046-0008	E-7	92055-3018	C-12	92104-1064	G-11	92145-1414	B-14
92009-1158	G-8	92033-1041	E-7	92046-037	C-4	92057-0129	F-3	92106-1001	G-11	92150-1019	C-12
92009-1164	F-14	92033-1102	F-10	92046-1010	C-6	92057-1531	B-10	92107-005	G-11	92150-1090	F-10
92009-1197	F-14	92033-1151	B-11	92046-1052	B-12	92058-0007	F-3	92107-1051	G-11	92150-1186	D-4
92009-1360	C-4	92033-1186	F-6	92046-1263	B-12	92059-103	B-5	92110-0019	G-11	92150-1406	C-8
92009-1378	G-7	92033-1186	F-8	92046-1272	E-8	92062-0004	C-4	92110-0020	G-11	92150-1604	F-10
92009-1570	F-6	92033-1222	F-11	92046-1273	E-8	92062-1056	C-4	92110-1015	G-11	92150-1760	E-6
92009-1905	B-14	92033-3731	D-3	92046-1291	B-13	92065-097	C-11	92110-1132	G-11	92150-1771	F-7
92015-1188	E-12	92037-010	B-5	92048-0005	B-13	92065-097	C-7	92110-1152	G-11	92150-1771	F-9
92015-1193	C-13	92037-010	F-12	92049-0022	E-3	92066-0002	B-3	92110-1161	G-11	92150-1841	C-6
92015-1233	F-6	92037-147	D-6	92049-0058	F-11	92066-0003	C-4	92110-3703	G-11	92150-1880	B-14
92015-1367	B-7	92037-1505	D-6	92049-1181	E-7	92066-0067	C-6	92111-1051	G-11	92151-1219	G-4
92015-1386	G-10	92037-1712	B-5	92049-1223	E-8	92066-0096	E-5	92112-1001	G-11	92151-1226	C-3

This catalog covers:
'07 ZX600P7F

GRID NO.

L-15

This grid covers:

Numerical Parts Index

Part No.	Grid No.	Part No.	Grid No.	Part No.	Grid No.	Part No.	Grid No.	Part No.	Grid No.	Part No.	Grid No.
92151-1389	C-4	92153-0406	B-3	92153-1574	C-6	92161-0308	B-7	92172-0175	G-9	92180-0147	B-9
92151-1521	C-6	92153-0410	G-9	92153-1582	C-6	92161-0342	F-3	92172-0175	H-4	92180-0148	B-9
92151-1523	F-10	92153-0421	C-3	92153-1610	B-3	92161-0381	C-11	92172-0183	F-10	92180-0149	B-12
92151-1532	B-7	92153-0489	E-6	92153-1612	E-10	92161-0419	B-7	92172-0188	G-10	92190-1185	F-4
92151-1540	C-6	92153-0489	F-13	92153-1612	E-6	92161-0440	F-11	92172-0272	C-9	92191-0023	C-8
92151-1583	C-6	92153-0489	G-8	92153-1616	F-12	92161-0475	B-7	92172-0290	F-11	92191-0025	C-8
92151-1609	E-4	92153-0489	H-5	92153-1621	E-5	92161-0518	F-12	92172-0309	C-8	92191-1001	E-12
92151-1611	F-12	92153-0508	E-8	92153-1631	C-5	92161-0532	B-7	92172-1060	F-10	92192-0018	C-8
92151-1611	G-7	92153-0627	F-6	92153-1632	C-5	92161-1300	C-3	92172-1061	E-11	92192-0347	B-5
92151-1626	C-13	92153-0627	F-8	92153-1633	C-5	92161-1313	G-7	92172-1061	G-10	92192-0348	B-5
92151-1654	E-5	92153-0628	F-6	92153-1637	C-5	92161-1330	F-12	92172-1072	B-5	92192-0352	C-11
92151-1654	G-4	92153-0656	B-3	92153-1638	C-5	92170-1060	B-5	92180-0108	B-8	92192-0423	B-4
92151-1654	G-5	92153-0684	G-7	92153-1639	C-4	92170-1090	F-6	92180-0109	B-8	92192-0429	B-5
92151-1774	C-11	92153-0797	B-12	92153-1640	B-10	92170-1091	F-6	92180-0110	B-8	92200-0006	H-4
92151-1774	D-4	92153-0799	E-4	92153-1640	C-4	92170-1091	F-8	92180-0111	B-8	92200-0006	H-5
92151-1797	E-12	92153-0816	G-4	92153-1649	C-12	92170-1128	C-11	92180-0112	B-8	92200-0036	E-3
92151-1802	E-12	92153-0817	B-7	92153-1650	D-5	92170-1493	D-6	92180-0113	B-8	92200-0043	E-9
92151-1829	B-10	92153-0817	F-8	92153-1651	C-6	92170-1577	C-6	92180-0114	B-8	92200-0047	C-5
92151-1874	D-3	92153-0854	F-11	92153-1667	F-10	92170-1577	C-7	92180-0115	B-8	92200-0050	B-13
92151-1915	E-4	92153-0855	F-11	92153-1690	E-4	92170-1577	G-9	92180-0116	B-8	92200-0051	B-13
92151-1930	B-10	92153-0868	F-6	92153-1691	E-4	92170-1938	B-4	92180-0117	B-8	92200-0078	B-7
92151-1946	G-10	92153-0873	E-11	92153-1716	C-6	92170-3729	D-5	92180-0118	B-8	92200-0138	B-13
92152-0017	F-6	92153-0873	G-4	92153-1771	F-11	92171-0011	G-9	92180-0119	B-8	92200-0153	C-5
92152-0076	E-4	92153-0873	H-4	92153-1779	B-4	92171-0133	B-7	92180-0120	B-8	92200-0157	H-5
92152-0091	C-13	92153-0873	H-5	92153-1792	C-12	92171-0179	D-6	92180-0121	B-8	92200-0164	G-8
92152-0091	F-12	92153-0875	B-6	92153-1812	E-3	92171-0255	B-4	92180-0122	B-8	92200-0165	G-8
92152-0103	F-10	92153-0880	C-3	92153-1837	F-7	92171-0292	B-7	92180-0123	B-8	92200-0193	B-3
92152-0134	C-11	92153-0907	F-10	92153-1855	C-13	92171-0316	G-3	92180-0124	B-8	92200-0198	C-3
92152-0154	E-7	92153-1003	E-7	92153-1857	F-8	92171-0316	G-9	92180-0125	B-8	92200-0199	C-3
92152-0188	B-7	92153-1086	C-12	92160-1041	E-11	92171-0359	C-8	92180-0126	B-8	92200-0209	E-3
92152-0214	F-3	92153-1093	F-7	92160-1116	B-7	92171-0406	F-6	92180-0127	B-8	92200-0212	G-10
92152-0237	G-4	92153-1136	E-3	92160-1162	B-5	92171-0462	G-9	92180-0128	B-8	92200-0238	D-3
92152-0240	E-14	92153-1172	B-11	92160-1167	F-14	92171-0480	F-8	92180-0129	B-8	92200-0265	C-3
92152-0242	E-14	92153-1244	G-8	92160-1167	G-6	92171-0652	G-9	92180-0130	B-8	92200-0317	C-12
92152-0286	B-7	92153-1244	H-4	92160-1167	G-7	92171-0725	B-5	92180-0131	B-8	92200-0343	F-11
92152-0289	E-14	92153-1244	H-5	92160-1613	G-4	92171-0729	B-3	92180-0132	B-8	92200-0383	B-11
92152-0352	G-10	92153-1275	B-7	92160-1613	H-4	92171-0776	F-8	92180-0133	B-8	92200-1019	D-3
92152-0413	B-10	92153-1283	C-10	92161-0041	C-11	92171-0778	F-8	92180-0134	B-8	92200-1065	B-13
92152-0444	B-13	92153-1284	B-4	92161-0046	E-11	92171-0912	G-3	92180-0135	B-9	92200-1087	B-5
92152-0522	F-11	92153-1407	E-7	92161-0070	C-12	92171-0938	C-6	92180-0136	B-9	92200-1087	F-12
92152-0543	F-3	92153-1505	C-3	92161-0095	F-13	92171-0974	G-9	92180-0137	B-9	92200-1167	E-7
92152-0544	F-3	92153-1518	F-6	92161-0117	G-10	92171-1185	C-6	92180-0138	B-9	92200-1249	C-13
92152-0547	B-5	92153-1521	D-3	92161-0118	G-10	92171-1415	G-4	92180-0139	B-9	92200-1260	B-12
92152-1074	D-4	92153-1526	E-11	92161-0149	F-13	92172-0009	B-6	92180-0140	B-9	92200-1277	B-13
92152-1074	G-10	92153-1526	E-6	92161-0203	G-9	92172-0064	C-8	92180-0141	B-9	92200-1278	B-13
92152-1182	F-12	92153-1545	E-8	92161-0204	G-4	92172-0064	C-9	92180-0142	B-9	92200-1388	E-10
92152-1458	G-7	92153-1546	E-8	92161-0240	G-10	92172-0129	C-8	92180-0143	B-9	92200-1423	B-12
92153-0303	E-9	92153-1547	E-8	92161-0257	G-10	92172-0175	G-6	92180-0144	B-9	92200-1479	F-3
92153-0393	F-8	92153-1548	E-7	92161-0273	F-8	92172-0175	G-7	92180-0145	B-9	92200-1487	B-12
92153-0405	D-3	92153-1569	C-7	92161-0283	G-9	92172-0175	G-8	92180-0146	B-9	92210-0001	E-11

This catalog covers:

'07 ZX600P7F

GRID NO.

L-16

This grid covers:

Numerical Parts Index

Part No.	Grid No.	Part No.	Grid No.	Part No.	Grid No.	Part No.	Grid No.	Part No.	Grid No.	Part No.	Grid No.
----------	----------	----------	----------	----------	----------	----------	----------	----------	----------	----------	----------

92210-0003H-4
92210-0006F-10
92210-0007C-11
92210-0007F-6
92210-0007G-10
92210-0095E-3
92210-0096E-3
92210-0099E-7
92210-0106E-7
92210-0121B-7

92210-0130B-7
92210-0130H-4
92210-0134E-7
92210-0152B-12
92210-0209E-3
92210-0276F-3
92210-0323B-13
92210-0384B-11
92210-1100C-3
92210-1101C-3

92210-1139E-4
92210-1139E-8
92210-1150E-8
92210-1266E-10
92210-1352B-7
92210-1355E-11
92210-1355F-13
92210-1390E-4
99996-1354-17HF-13
99996-1354-777F-13

99996-1354-H8F-13
99999-0088C-8
99999-0089C-8

This catalog covers:

'07 ZX600P7F

GRID NO.

B-16

This grid covers:

Part Name Index

Air Cleaner.....	B-5
Air Duct.....	B-6
Brake Pedal.....	F-4
Cables.....	G-3
Camshaft(s).....	B-10
Chain Cover.....	G-5
Chassis Electrical Equipment.....	G-9
Clutch.....	B-12
Cowling.....	H-4
Cowling Lowers.....	H-5
Crankcase.....	C-4
Crankcase Bolt Pattern.....	C-5
Crankshaft.....	B-11
Cylinder Head.....	B-3
Cylinder Head Cover.....	B-4
Decals(Ebony).....	G-13
Decals(Green).....	G-14
Decals(Orange).....	H-3
Engine Cover(s).....	C-6
Engine Mount.....	E-4
Footrests.....	E-9
Frame.....	E-3
Frame Fittings(Front).....	E-5
Frame Fittings(Rear).....	E-6
Front Brake.....	F-7
Front Fender(s).....	E-10
Front Fork.....	F-11
Front Hub.....	E-14
Front Master Cylinder.....	F-6
Fuel Injection.....	C-11
Fuel Pump.....	C-10
Fuel Tank.....	F-12
Gear Change Drum.....	B-14
Gear Change Mechanism.....	C-3
Generator.....	C-13

Handlebar.....	F-10
Headlight(s).....	G-6
Ignition Switch.....	G-10
Ignition System.....	C-14
Labels.....	G-12
Meter(s).....	F-14
Muffler(s).....	B-7
Oil Cooler.....	D-5
Oil Pan.....	C-7
Oil Pump.....	C-12
Owner's Tools.....	G-11
Piston(s).....	B-11
Radiator.....	D-4
Rear Brake.....	F-9
Rear Fender(s).....	E-11
Rear Hub.....	F-3
Rear Master Cylinder.....	F-8
Seat.....	F-13
Shift Fork(s).....	B-14
Shock Absorber(s).....	F-5
Side Covers.....	G-4
Stand(s).....	E-12
Starter Motor.....	D-3
Suspension.....	E-8
Swingarm.....	E-7
Taillight(s).....	G-7
Tensioner.....	B-10
Throttle.....	C-8
Tires.....	E-13
Top Feed Injector.....	C-9
Transmission.....	B-13
Turn Signals.....	G-8
Valve(s).....	B-8/B-9
Water Pipe.....	D-6

This catalog covers:

'07 ZX600P7F

GRID NO.

C-16

This grid covers:

Part Name Index

Air Cleaner.....	B-5
Air Duct.....	B-6
Brake Pedal.....	F-4
Cables.....	G-3
Camshaft(s).....	B-10
Chain Cover.....	G-5
Chassis Electrical Equipment.....	G-9
Clutch.....	B-12
Cowling.....	H-4
Cowling Lowers.....	H-5
Crankcase.....	C-4
Crankcase Bolt Pattern.....	C-5
Crankshaft.....	B-11
Cylinder Head.....	B-3
Cylinder Head Cover.....	B-4
Decals(Ebony).....	G-13
Decals(Green).....	G-14
Decals(Orange).....	H-3
Engine Cover(s).....	C-6
Engine Mount.....	E-4
Footrests.....	E-9
Frame.....	E-3
Frame Fittings(Front).....	E-5
Frame Fittings(Rear).....	E-6
Front Brake.....	F-7
Front Fender(s).....	E-10
Front Fork.....	F-11
Front Hub.....	E-14
Front Master Cylinder.....	F-6
Fuel Injection.....	C-11
Fuel Pump.....	C-10
Fuel Tank.....	F-12
Gear Change Drum.....	B-14
Gear Change Mechanism.....	C-3
Generator.....	C-13

Handlebar.....	F-10
Headlight(s).....	G-6
Ignition Switch.....	G-10
Ignition System.....	C-14
Labels.....	G-12
Meter(s).....	F-14
Muffler(s).....	B-7
Oil Cooler.....	D-5
Oil Pan.....	C-7
Oil Pump.....	C-12
Owner's Tools.....	G-11
Piston(s).....	B-11
Radiator.....	D-4
Rear Brake.....	F-9
Rear Fender(s).....	E-11
Rear Hub.....	F-3
Rear Master Cylinder.....	F-8
Seat.....	F-13
Shift Fork(s).....	B-14
Shock Absorber(s).....	F-5
Side Covers.....	G-4
Stand(s).....	E-12
Starter Motor.....	D-3
Suspension.....	E-8
Swingarm.....	E-7
Taillight(s).....	G-7
Tensioner.....	B-10
Throttle.....	C-8
Tires.....	E-13
Top Feed Injector.....	C-9
Transmission.....	B-13
Turn Signals.....	G-8
Valve(s).....	B-8/B-9
Water Pipe.....	D-6

This catalog covers:

'07 ZX600P7F

GRID NO.

D-16

This grid covers:

Part Name Index

Air Cleaner.....	B-5
Air Duct.....	B-6
Brake Pedal.....	F-4
Cables.....	G-3
Camshaft(s).....	B-10
Chain Cover.....	G-5
Chassis Electrical Equipment.....	G-9
Clutch.....	B-12
Cowling.....	H-4
Cowling Lowers.....	H-5
Crankcase.....	C-4
Crankcase Bolt Pattern.....	C-5
Crankshaft.....	B-11
Cylinder Head.....	B-3
Cylinder Head Cover.....	B-4
Decals(Ebony).....	G-13
Decals(Green).....	G-14
Decals(Orange).....	H-3
Engine Cover(s).....	C-6
Engine Mount.....	E-4
Footrests.....	E-9
Frame.....	E-3
Frame Fittings(Front).....	E-5
Frame Fittings(Rear).....	E-6
Front Brake.....	F-7
Front Fender(s).....	E-10
Front Fork.....	F-11
Front Hub.....	E-14
Front Master Cylinder.....	F-6
Fuel Injection.....	C-11
Fuel Pump.....	C-10
Fuel Tank.....	F-12
Gear Change Drum.....	B-14
Gear Change Mechanism.....	C-3
Generator.....	C-13

Handlebar.....	F-10
Headlight(s).....	G-6
Ignition Switch.....	G-10
Ignition System.....	C-14
Labels.....	G-12
Meter(s).....	F-14
Muffler(s).....	B-7
Oil Cooler.....	D-5
Oil Pan.....	C-7
Oil Pump.....	C-12
Owner's Tools.....	G-11
Piston(s).....	B-11
Radiator.....	D-4
Rear Brake.....	F-9
Rear Fender(s).....	E-11
Rear Hub.....	F-3
Rear Master Cylinder.....	F-8
Seat.....	F-13
Shift Fork(s).....	B-14
Shock Absorber(s).....	F-5
Side Covers.....	G-4
Stand(s).....	E-12
Starter Motor.....	D-3
Suspension.....	E-8
Swingarm.....	E-7
Taillight(s).....	G-7
Tensioner.....	B-10
Throttle.....	C-8
Tires.....	E-13
Top Feed Injector.....	C-9
Transmission.....	B-13
Turn Signals.....	G-8
Valve(s).....	B-8/B-9
Water Pipe.....	D-6

This catalog covers:

'07 ZX600P7F

GRID NO.

E-16

This grid covers:

Part Name Index

Air Cleaner.....	B-5
Air Duct.....	B-6
Brake Pedal.....	F-4
Cables.....	G-3
Camshaft(s).....	B-10
Chain Cover.....	G-5
Chassis Electrical Equipment.....	G-9
Clutch.....	B-12
Cowling.....	H-4
Cowling Lowers.....	H-5
Crankcase.....	C-4
Crankcase Bolt Pattern.....	C-5
Crankshaft.....	B-11
Cylinder Head.....	B-3
Cylinder Head Cover.....	B-4
Decals(Ebony).....	G-13
Decals(Green).....	G-14
Decals(Orange).....	H-3
Engine Cover(s).....	C-6
Engine Mount.....	E-4
Footrests.....	E-9
Frame.....	E-3
Frame Fittings(Front).....	E-5
Frame Fittings(Rear).....	E-6
Front Brake.....	F-7
Front Fender(s).....	E-10
Front Fork.....	F-11
Front Hub.....	E-14
Front Master Cylinder.....	F-6
Fuel Injection.....	C-11
Fuel Pump.....	C-10
Fuel Tank.....	F-12
Gear Change Drum.....	B-14
Gear Change Mechanism.....	C-3
Generator.....	C-13

Handlebar.....	F-10
Headlight(s).....	G-6
Ignition Switch.....	G-10
Ignition System.....	C-14
Labels.....	G-12
Meter(s).....	F-14
Muffler(s).....	B-7
Oil Cooler.....	D-5
Oil Pan.....	C-7
Oil Pump.....	C-12
Owner's Tools.....	G-11
Piston(s).....	B-11
Radiator.....	D-4
Rear Brake.....	F-9
Rear Fender(s).....	E-11
Rear Hub.....	F-3
Rear Master Cylinder.....	F-8
Seat.....	F-13
Shift Fork(s).....	B-14
Shock Absorber(s).....	F-5
Side Covers.....	G-4
Stand(s).....	E-12
Starter Motor.....	D-3
Suspension.....	E-8
Swingarm.....	E-7
Taillight(s).....	G-7
Tensioner.....	B-10
Throttle.....	C-8
Tires.....	E-13
Top Feed Injector.....	C-9
Transmission.....	B-13
Turn Signals.....	G-8
Valve(s).....	B-8/B-9
Water Pipe.....	D-6

This catalog covers:
'07 ZX600P7F

GRID NO.

F-16

This grid covers:

Part Name Index

Air Cleaner.....	B-5
Air Duct.....	B-6
Brake Pedal.....	F-4
Cables.....	G-3
Camshaft(s).....	B-10
Chain Cover.....	G-5
Chassis Electrical Equipment.....	G-9
Clutch.....	B-12
Cowling.....	H-4
Cowling Lowers.....	H-5
Crankcase.....	C-4
Crankcase Bolt Pattern.....	C-5
Crankshaft.....	B-11
Cylinder Head.....	B-3
Cylinder Head Cover.....	B-4
Decals(Ebony).....	G-13
Decals(Green).....	G-14
Decals(Orange).....	H-3
Engine Cover(s).....	C-6
Engine Mount.....	E-4
Footrests.....	E-9
Frame.....	E-3
Frame Fittings(Front).....	E-5
Frame Fittings(Rear).....	E-6
Front Brake.....	F-7
Front Fender(s).....	E-10
Front Fork.....	F-11
Front Hub.....	E-14
Front Master Cylinder.....	F-6
Fuel Injection.....	C-11
Fuel Pump.....	C-10
Fuel Tank.....	F-12
Gear Change Drum.....	B-14
Gear Change Mechanism.....	C-3
Generator.....	C-13

Handlebar.....	F-10
Headlight(s).....	G-6
Ignition Switch.....	G-10
Ignition System.....	C-14
Labels.....	G-12
Meter(s).....	F-14
Muffler(s).....	B-7
Oil Cooler.....	D-5
Oil Pan.....	C-7
Oil Pump.....	C-12
Owner's Tools.....	G-11
Piston(s).....	B-11
Radiator.....	D-4
Rear Brake.....	F-9
Rear Fender(s).....	E-11
Rear Hub.....	F-3
Rear Master Cylinder.....	F-8
Seat.....	F-13
Shift Fork(s).....	B-14
Shock Absorber(s).....	F-5
Side Covers.....	G-4
Stand(s).....	E-12
Starter Motor.....	D-3
Suspension.....	E-8
Swingarm.....	E-7
Taillight(s).....	G-7
Tensioner.....	B-10
Throttle.....	C-8
Tires.....	E-13
Top Feed Injector.....	C-9
Transmission.....	B-13
Turn Signals.....	G-8
Valve(s).....	B-8/B-9
Water Pipe.....	D-6

This catalog covers:

'07 ZX600P7F

GRID NO.

G-16

This grid covers:

Part Name Index

Air Cleaner.....	B-5
Air Duct.....	B-6
Brake Pedal.....	F-4
Cables.....	G-3
Camshaft(s).....	B-10
Chain Cover.....	G-5
Chassis Electrical Equipment.....	G-9
Clutch.....	B-12
Cowling.....	H-4
Cowling Lowers.....	H-5
Crankcase.....	C-4
Crankcase Bolt Pattern.....	C-5
Crankshaft.....	B-11
Cylinder Head.....	B-3
Cylinder Head Cover.....	B-4
Decals(Ebony).....	G-13
Decals(Green).....	G-14
Decals(Orange).....	H-3
Engine Cover(s).....	C-6
Engine Mount.....	E-4
Footrests.....	E-9
Frame.....	E-3
Frame Fittings(Front).....	E-5
Frame Fittings(Rear).....	E-6
Front Brake.....	F-7
Front Fender(s).....	E-10
Front Fork.....	F-11
Front Hub.....	E-14
Front Master Cylinder.....	F-6
Fuel Injection.....	C-11
Fuel Pump.....	C-10
Fuel Tank.....	F-12
Gear Change Drum.....	B-14
Gear Change Mechanism.....	C-3
Generator.....	C-13

Handlebar.....	F-10
Headlight(s).....	G-6
Ignition Switch.....	G-10
Ignition System.....	C-14
Labels.....	G-12
Meter(s).....	F-14
Muffler(s).....	B-7
Oil Cooler.....	D-5
Oil Pan.....	C-7
Oil Pump.....	C-12
Owner's Tools.....	G-11
Piston(s).....	B-11
Radiator.....	D-4
Rear Brake.....	F-9
Rear Fender(s).....	E-11
Rear Hub.....	F-3
Rear Master Cylinder.....	F-8
Seat.....	F-13
Shift Fork(s).....	B-14
Shock Absorber(s).....	F-5
Side Covers.....	G-4
Stand(s).....	E-12
Starter Motor.....	D-3
Suspension.....	E-8
Swingarm.....	E-7
Taillight(s).....	G-7
Tensioner.....	B-10
Throttle.....	C-8
Tires.....	E-13
Top Feed Injector.....	C-9
Transmission.....	B-13
Turn Signals.....	G-8
Valve(s).....	B-8/B-9
Water Pipe.....	D-6

This catalog covers:

'07 ZX600P7F

GRID NO.

H-16

This grid covers:

Part Name Index

Air Cleaner.....	B-5
Air Duct.....	B-6
Brake Pedal.....	F-4
Cables.....	G-3
Camshaft(s).....	B-10
Chain Cover.....	G-5
Chassis Electrical Equipment.....	G-9
Clutch.....	B-12
Cowling.....	H-4
Cowling Lowers.....	H-5
Crankcase.....	C-4
Crankcase Bolt Pattern.....	C-5
Crankshaft.....	B-11
Cylinder Head.....	B-3
Cylinder Head Cover.....	B-4
Decals(Ebony).....	G-13
Decals(Green).....	G-14
Decals(Orange).....	H-3
Engine Cover(s).....	C-6
Engine Mount.....	E-4
Footrests.....	E-9
Frame.....	E-3
Frame Fittings(Front).....	E-5
Frame Fittings(Rear).....	E-6
Front Brake.....	F-7
Front Fender(s).....	E-10
Front Fork.....	F-11
Front Hub.....	E-14
Front Master Cylinder.....	F-6
Fuel Injection.....	C-11
Fuel Pump.....	C-10
Fuel Tank.....	F-12
Gear Change Drum.....	B-14
Gear Change Mechanism.....	C-3
Generator.....	C-13

Handlebar.....	F-10
Headlight(s).....	G-6
Ignition Switch.....	G-10
Ignition System.....	C-14
Labels.....	G-12
Meter(s).....	F-14
Muffler(s).....	B-7
Oil Cooler.....	D-5
Oil Pan.....	C-7
Oil Pump.....	C-12
Owner's Tools.....	G-11
Piston(s).....	B-11
Radiator.....	D-4
Rear Brake.....	F-9
Rear Fender(s).....	E-11
Rear Hub.....	F-3
Rear Master Cylinder.....	F-8
Seat.....	F-13
Shift Fork(s).....	B-14
Shock Absorber(s).....	F-5
Side Covers.....	G-4
Stand(s).....	E-12
Starter Motor.....	D-3
Suspension.....	E-8
Swingarm.....	E-7
Taillight(s).....	G-7
Tensioner.....	B-10
Throttle.....	C-8
Tires.....	E-13
Top Feed Injector.....	C-9
Transmission.....	B-13
Turn Signals.....	G-8
Valve(s).....	B-8/B-9
Water Pipe.....	D-6