

This catalog covers:
'08 ZX1000 E8F

GRID NO. **A-1** This grid covers:
Title



PARTS CATALOG

'08 ZX1000 E8F

(NINJA ZX-10R)

Publications	A-2
Model Identification	A-4
Engine	B-1
Chassis	E-1

© Kawasaki Heavy Industries, Ltd. 2008

Engine No. Location:
Upper crankcase, rear side

Year & Model	'08 ZX1000E8F
Color	1. Lime Green (777) 2. Metallic Diablo Black (17K) 3. Pearl Wildfire Orange (17H)
VIN No. Range	JKAZXT00EEA000001 ~
Engine No. Range	ZXT00DE000001 ~

This catalog covers:
'08 ZX1000 E8F

GRID NO. **A-2** This grid covers:
Publications

Year & Model	Owner's Manual	A&P Manual		Service Manual		Microfiche
		General	Supplement	Basic	Supplement	
2008 ZX1000E8F	99976-1342(EN/FR/DE) 99976-1366(IT/ES/NL) 99986-1401(English Only)	99931-1484-01		99924-1388-01		99912-1534-01

This catalog covers:
'08 ZX1000 E8F

GRID NO.

A-4

This grid covers:
Model I.D. '08 ZX1000E8F

ZX1000E8F

Left Side View

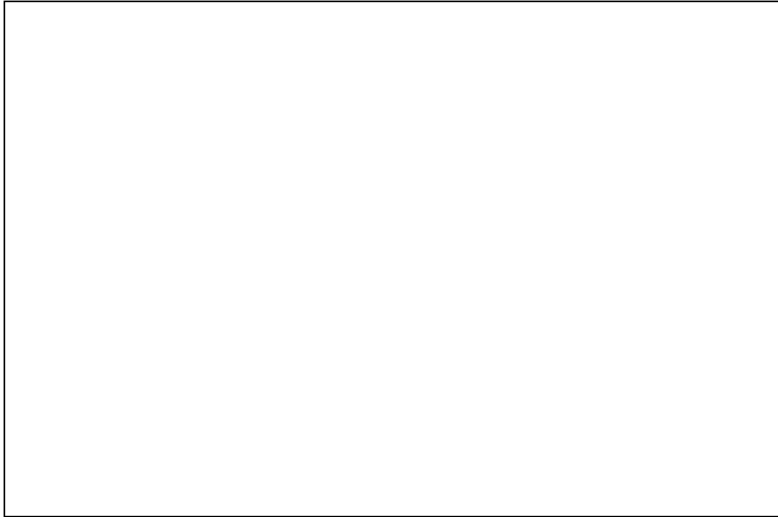

Right Side View

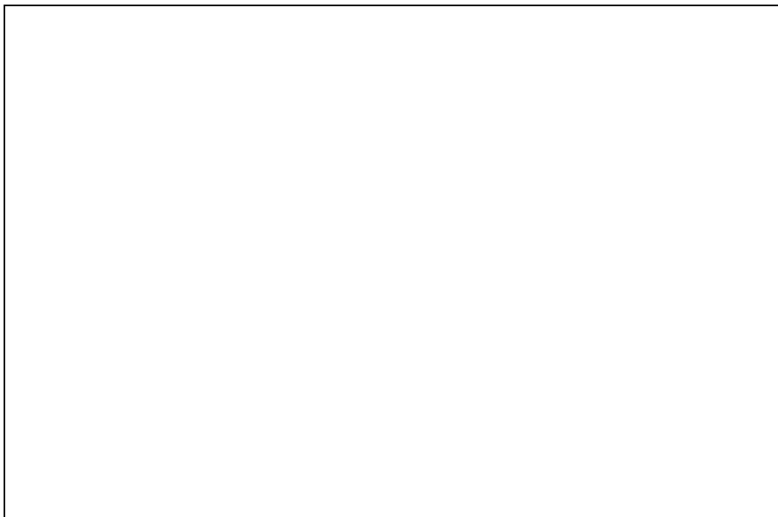

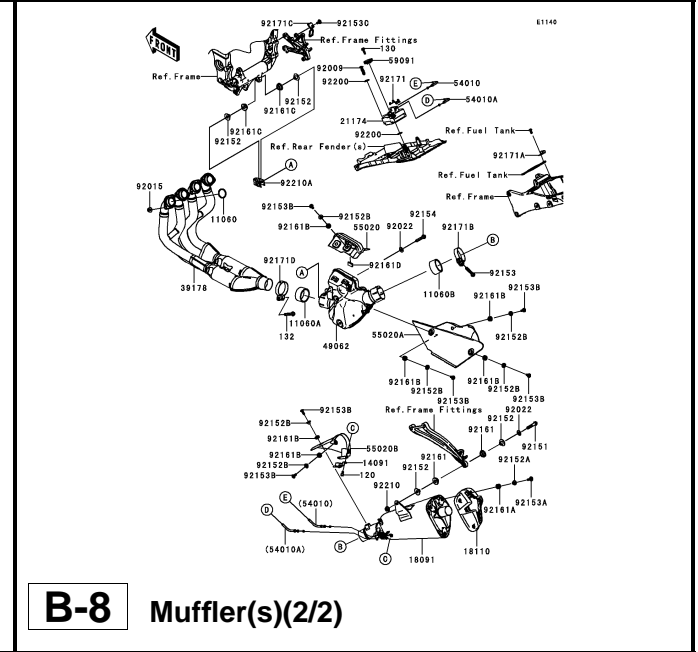
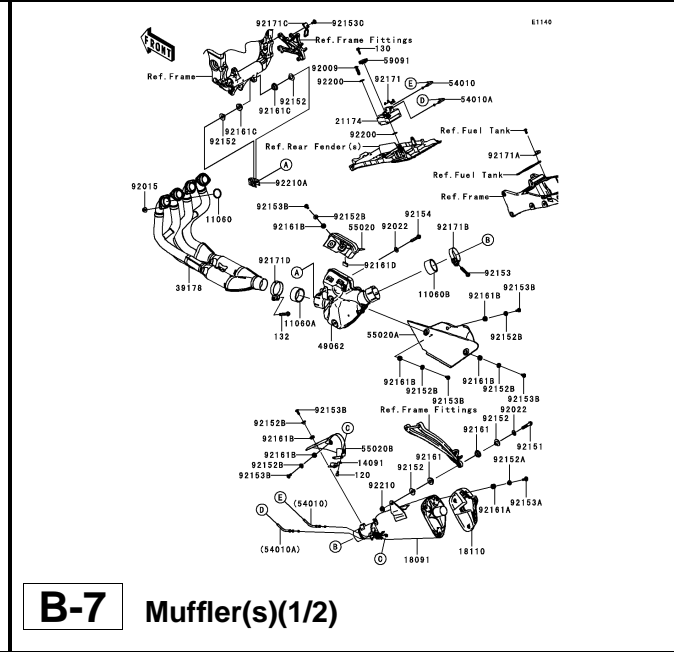
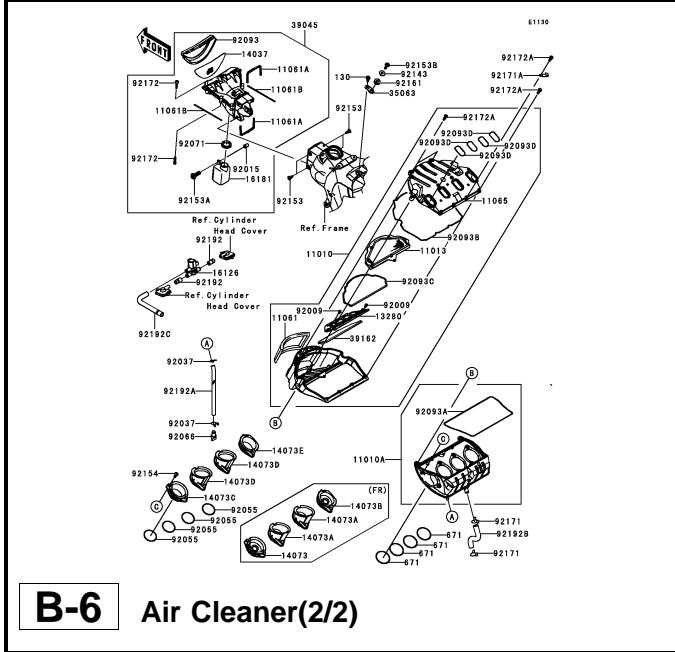
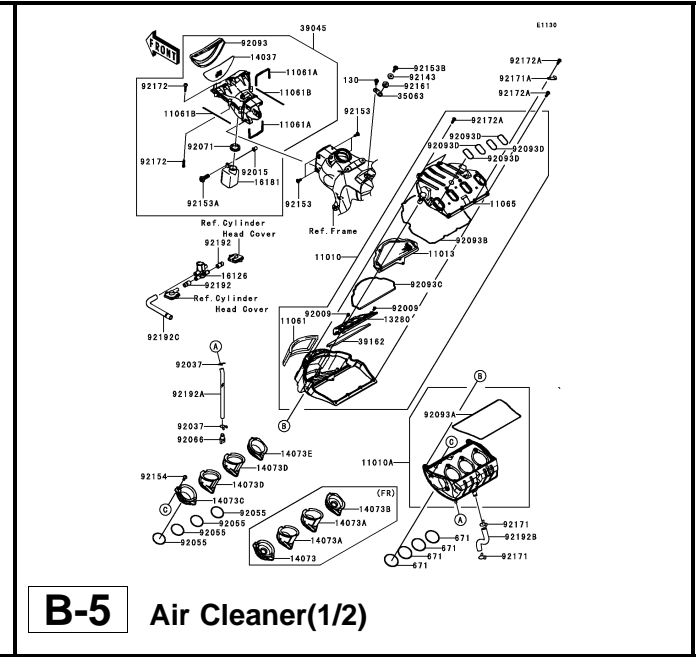
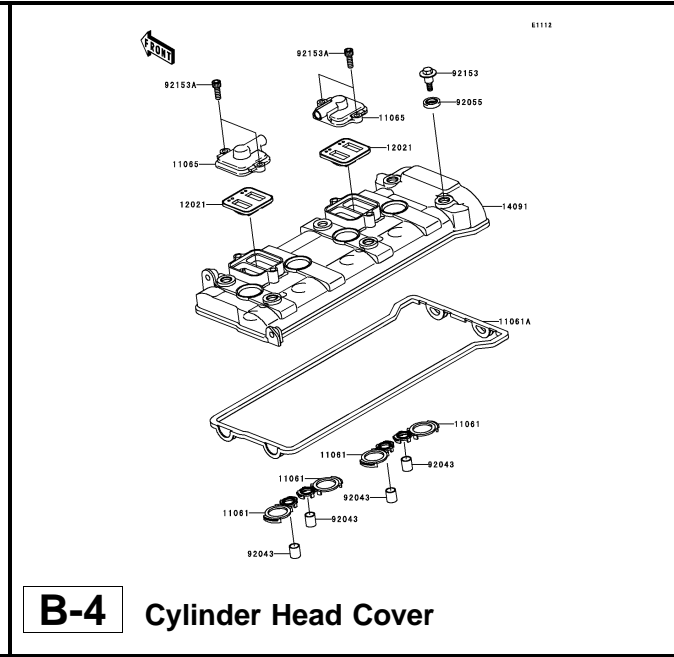
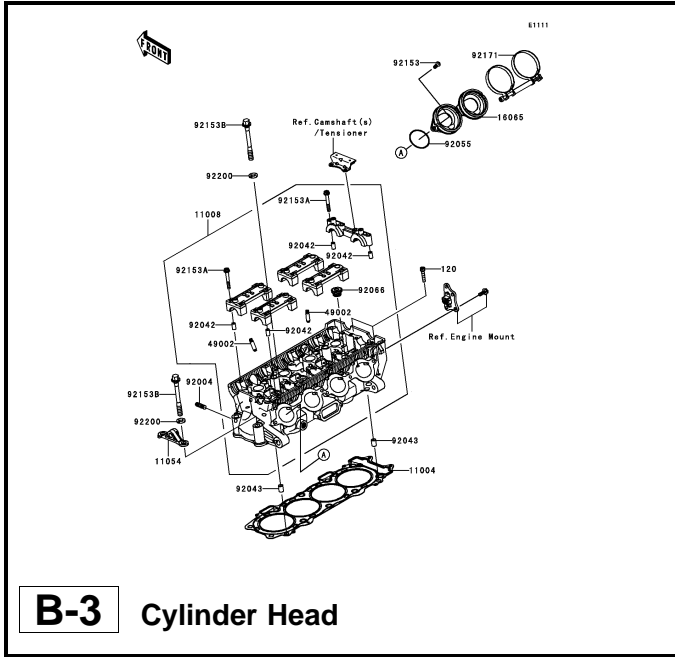

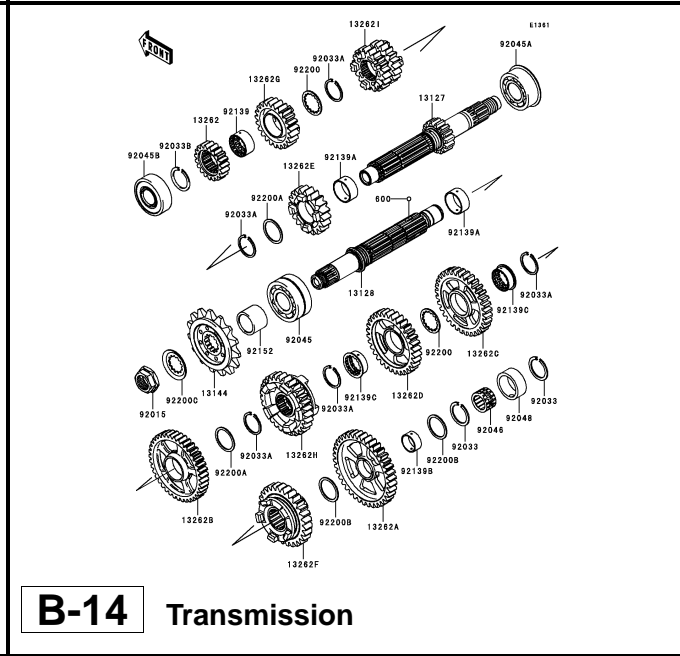
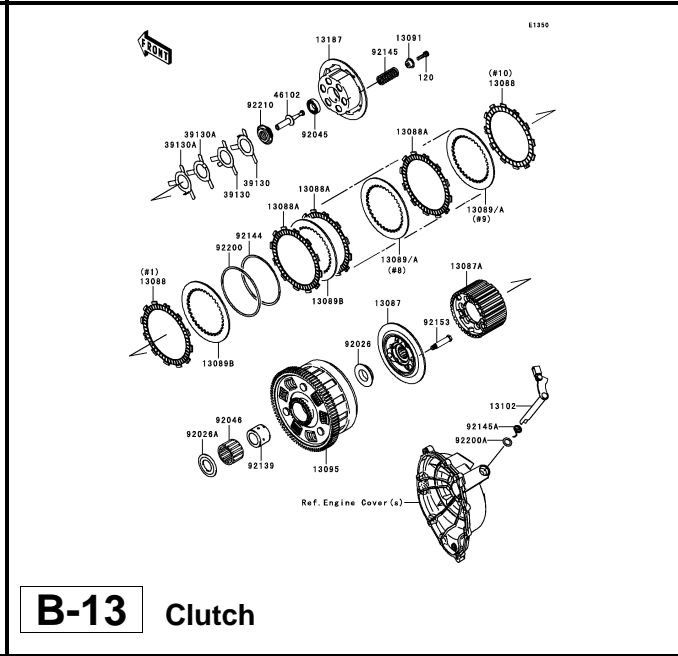
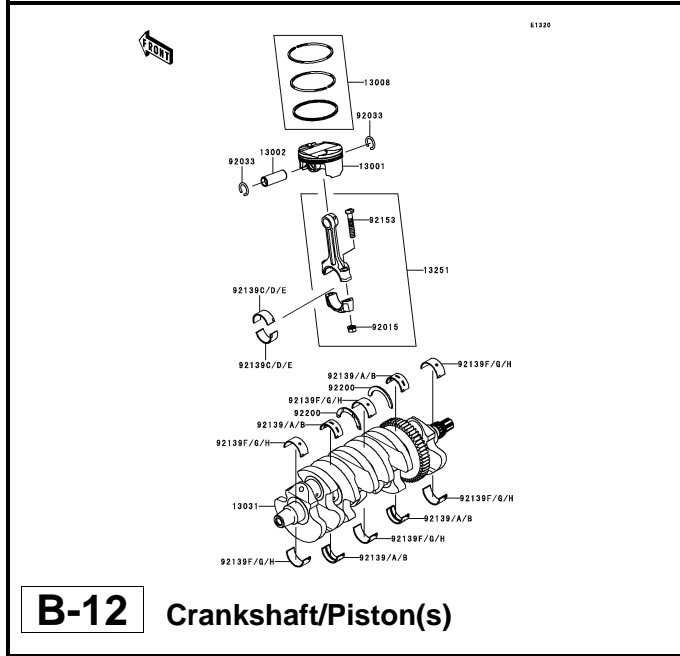
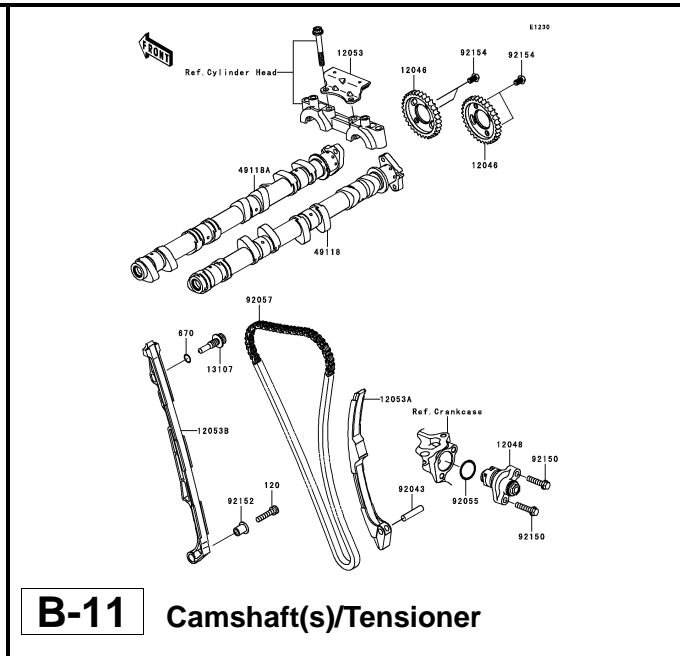
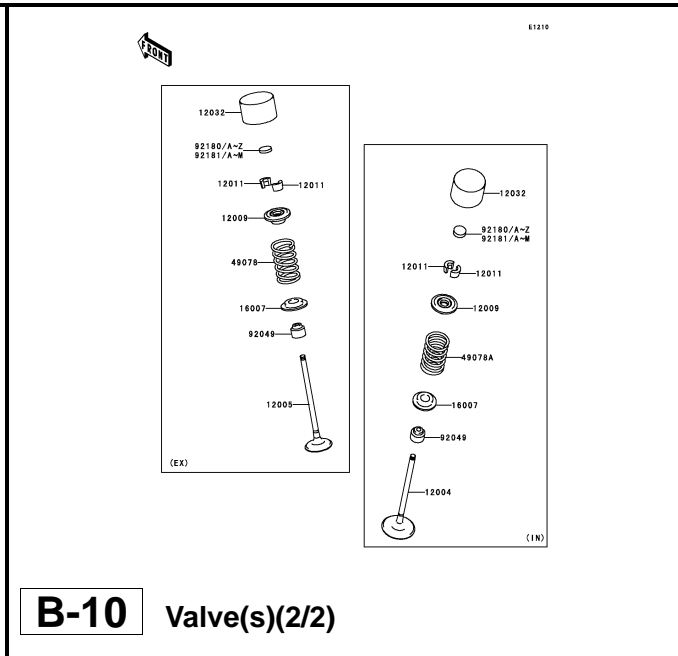
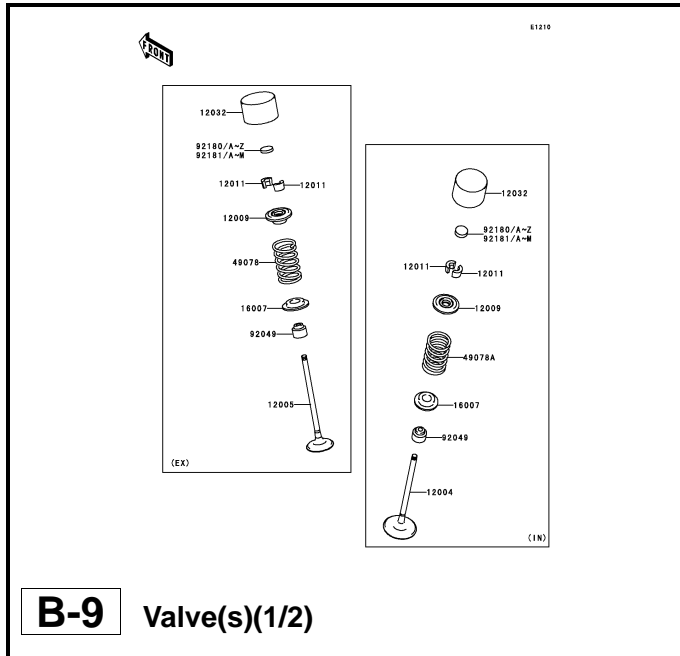

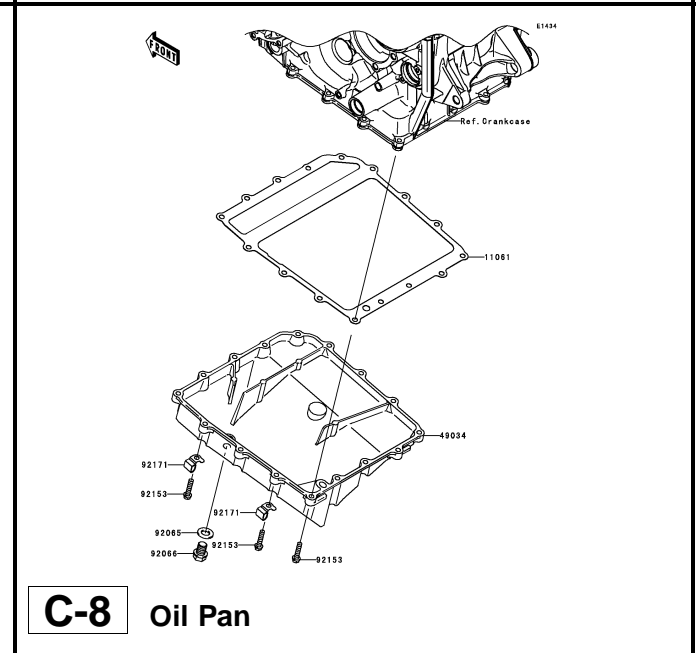
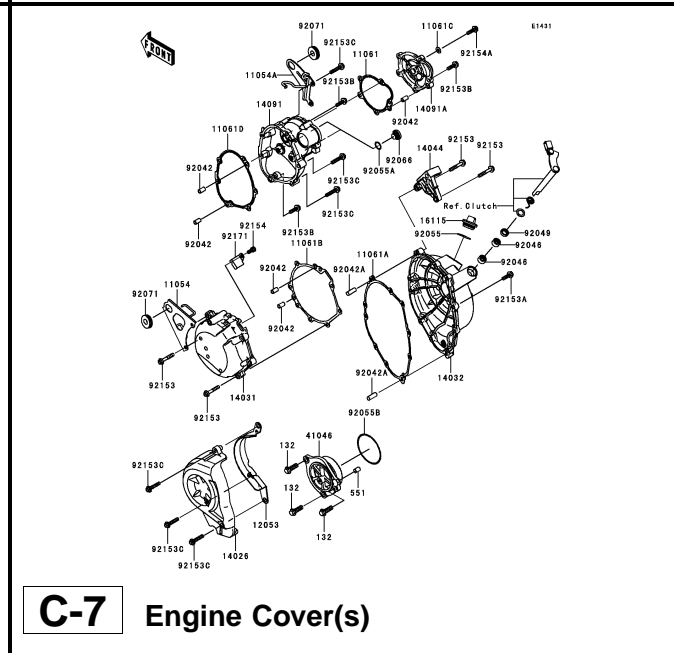
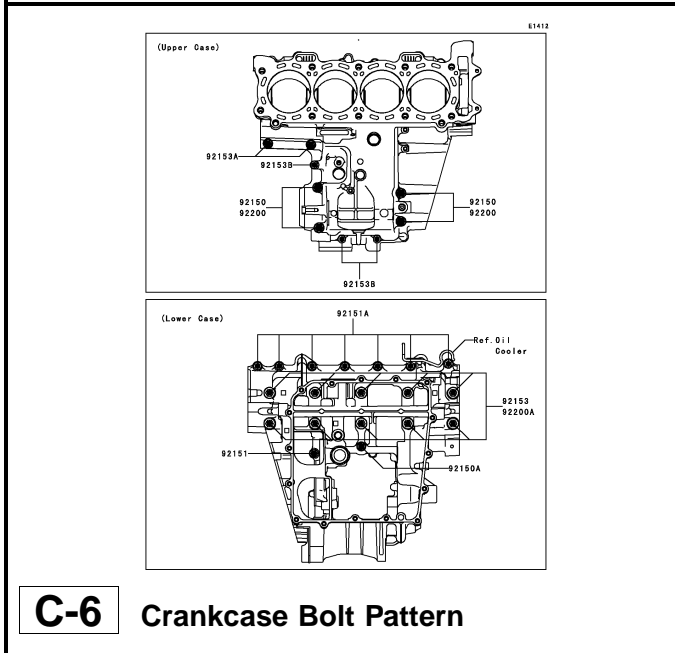
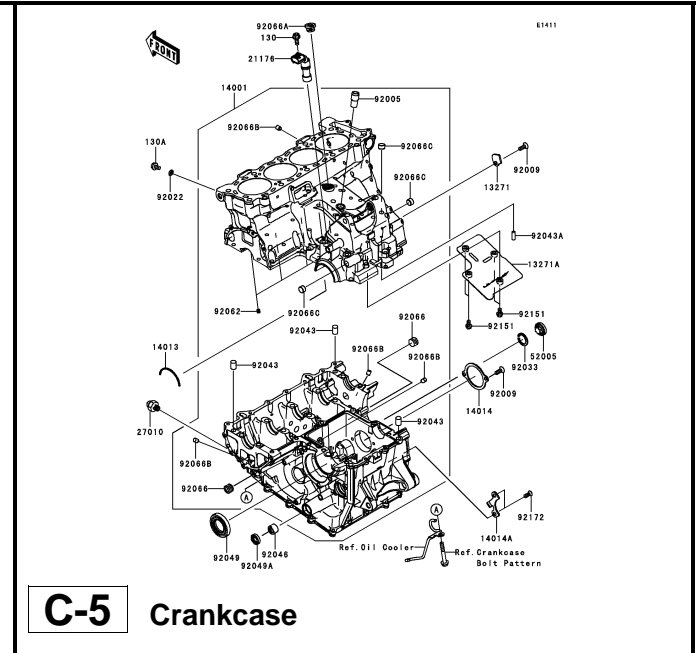
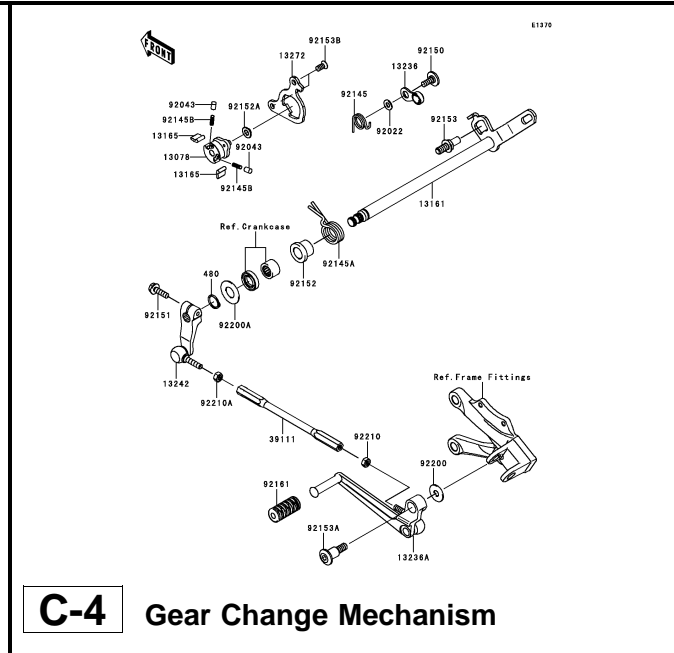
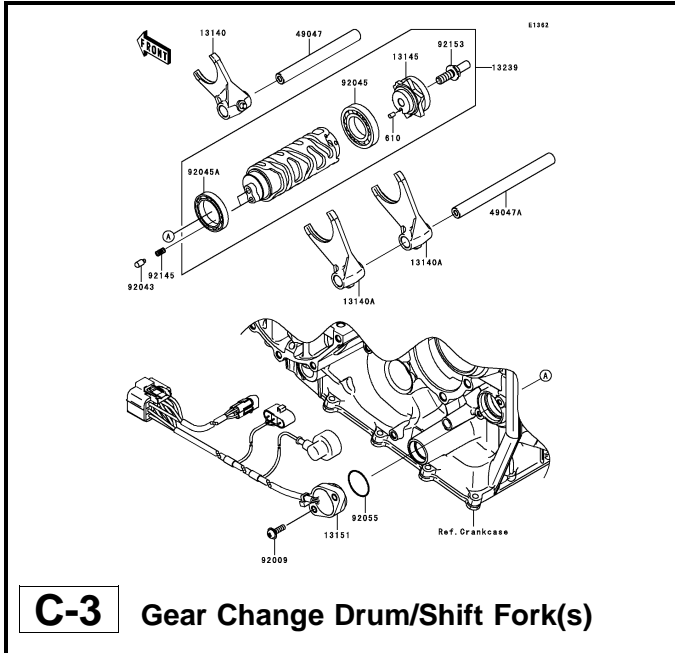

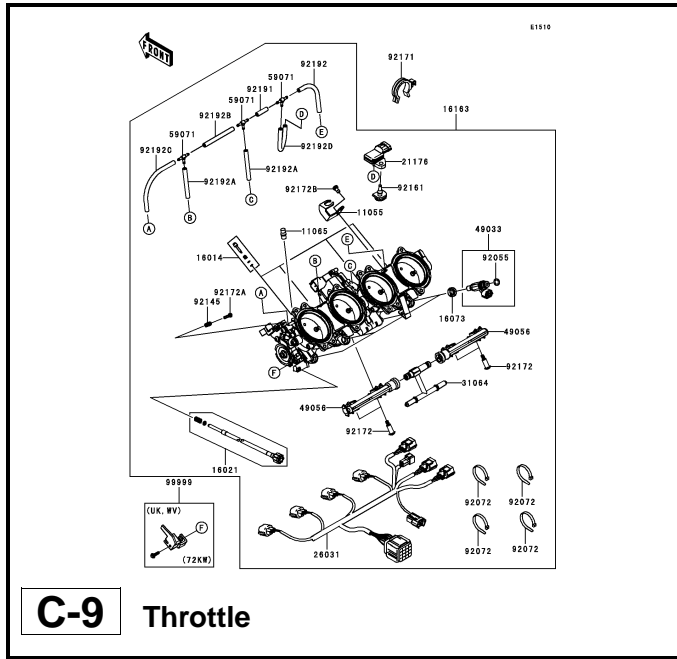

C-9 Throttle

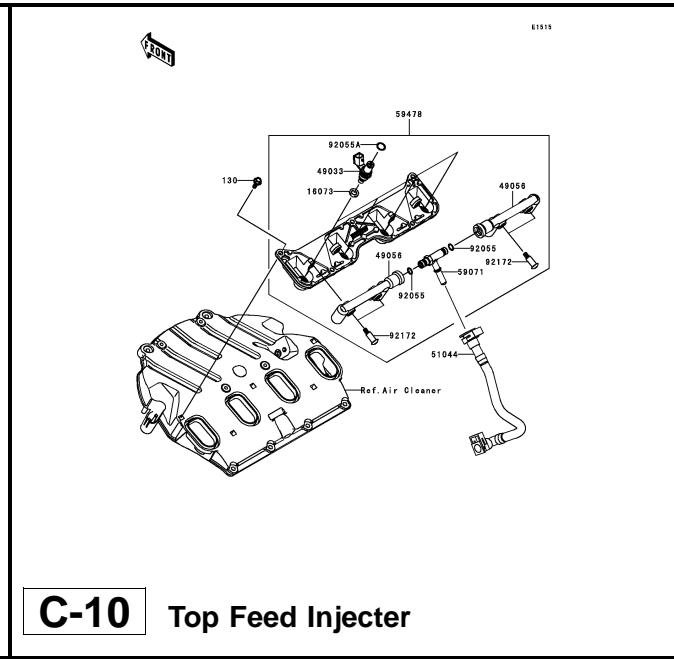

C-10 Top Feed Injector

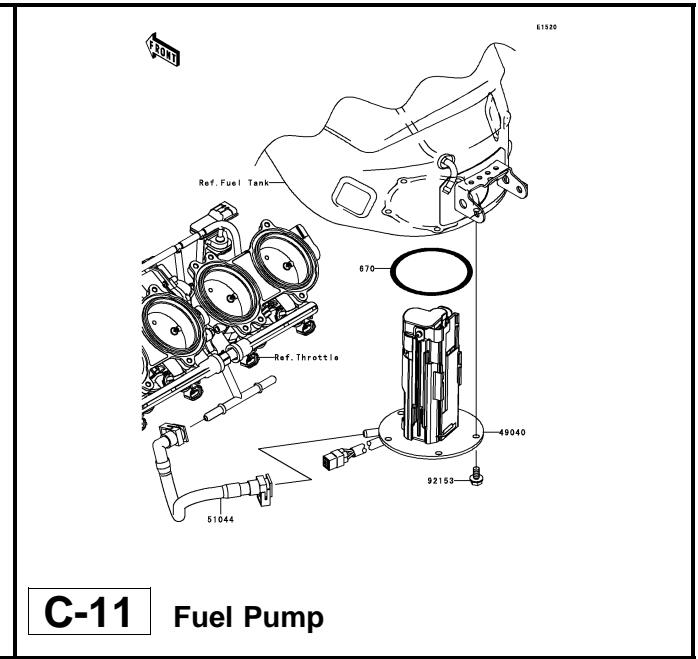

C-11 Fuel Pump

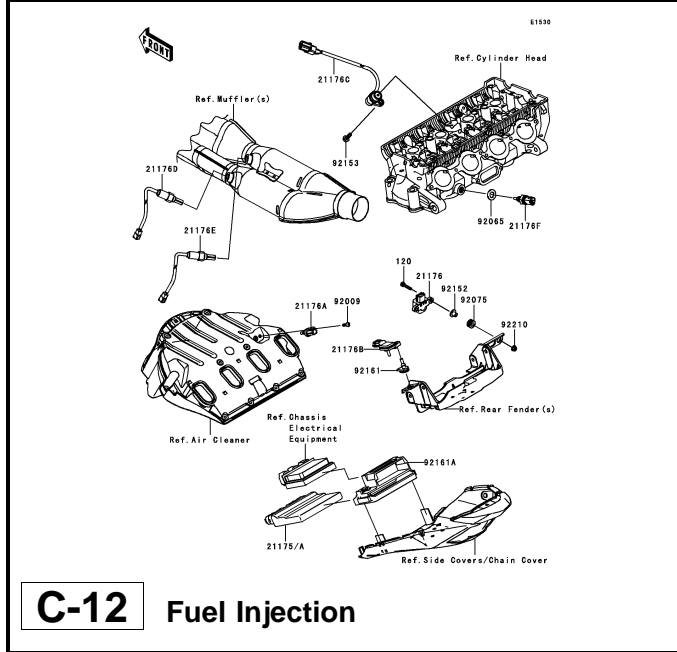

C-12 Fuel Injection

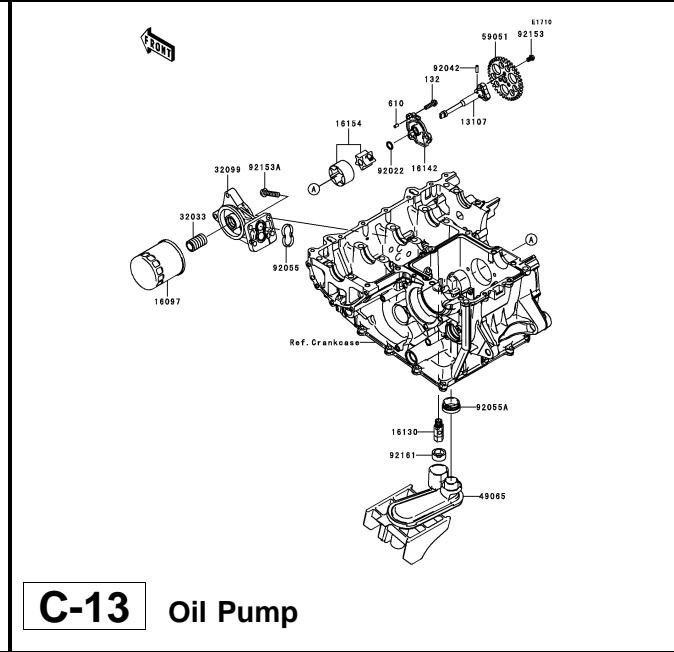

C-13 Oil Pump

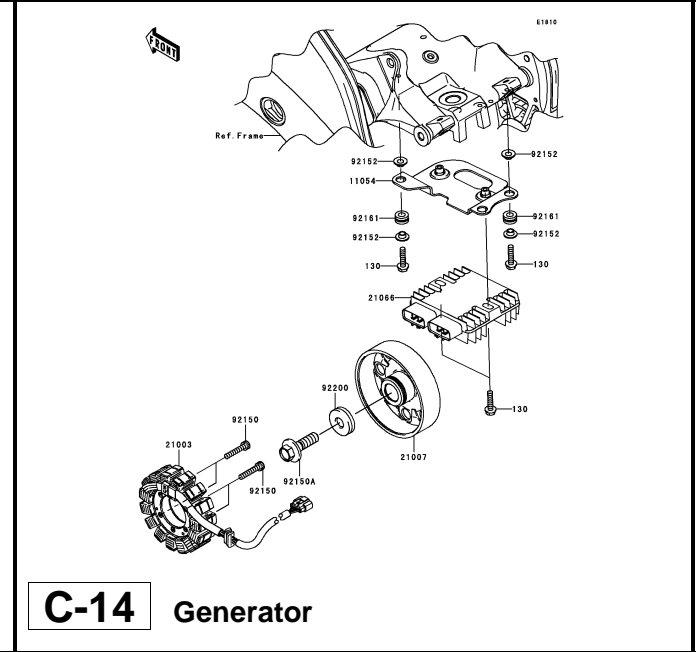

C-14 Generator

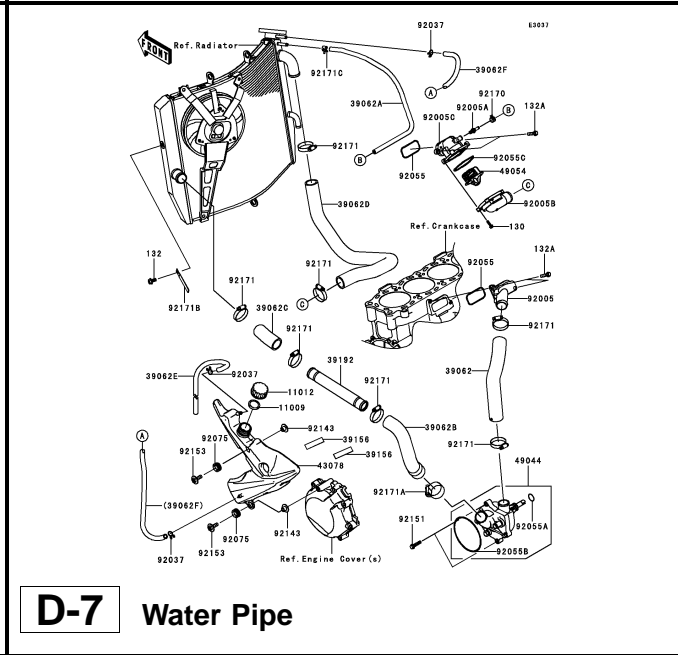
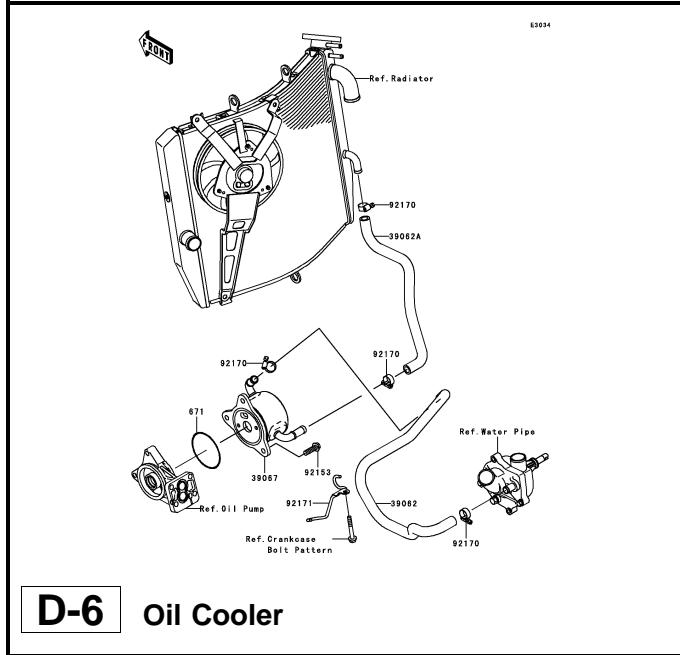
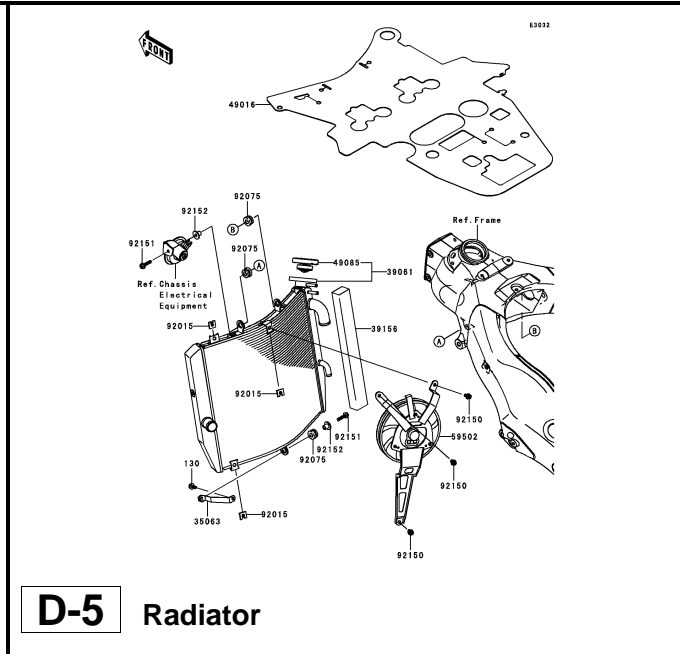
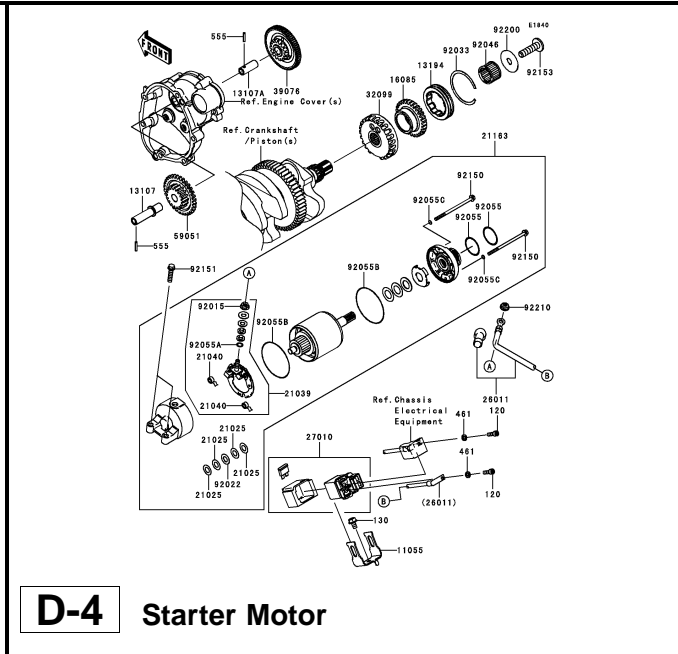
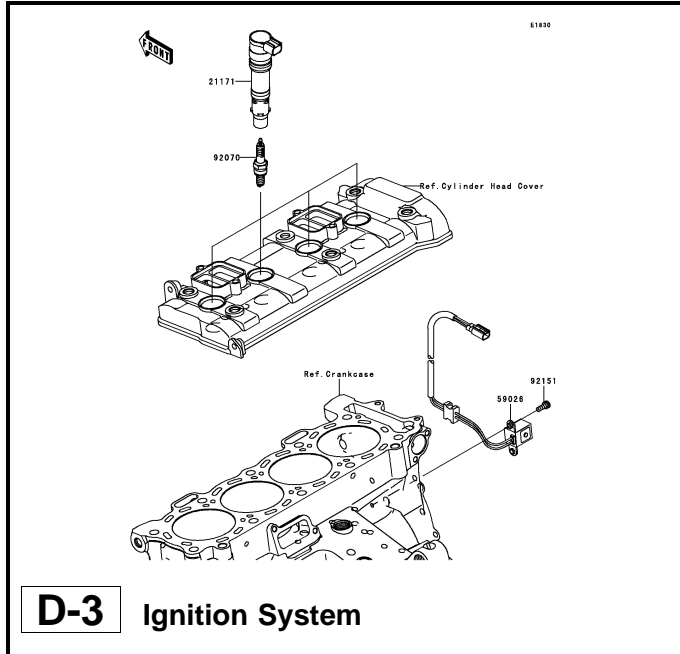

This catalog covers:

'08 ZX1000E8F Engine

GRID NO.

D-2

This grid covers:

Pictorial Index

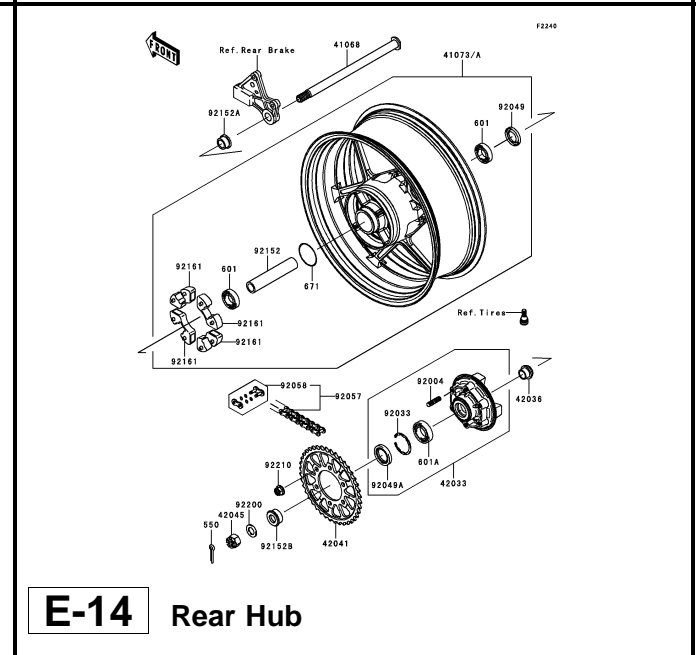
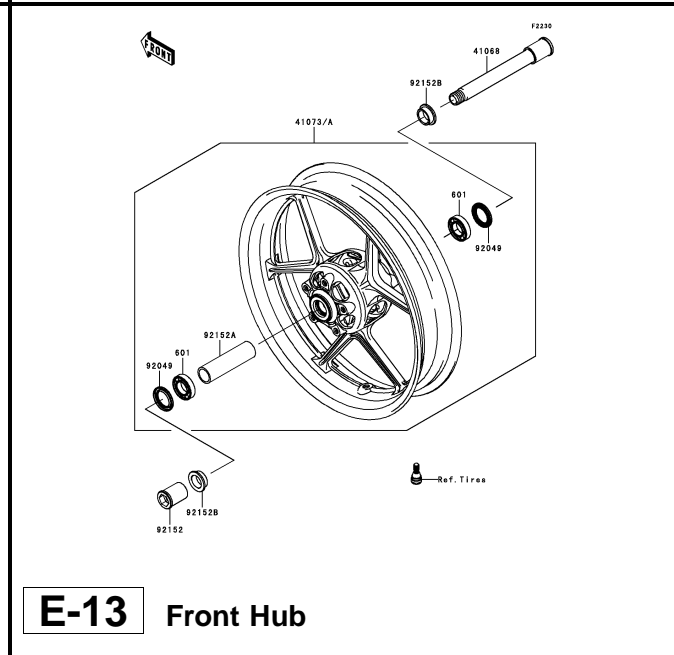
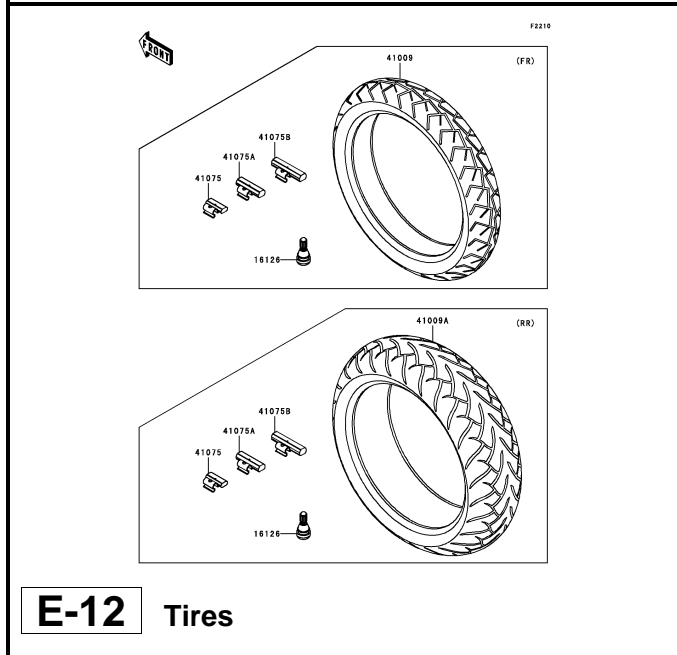
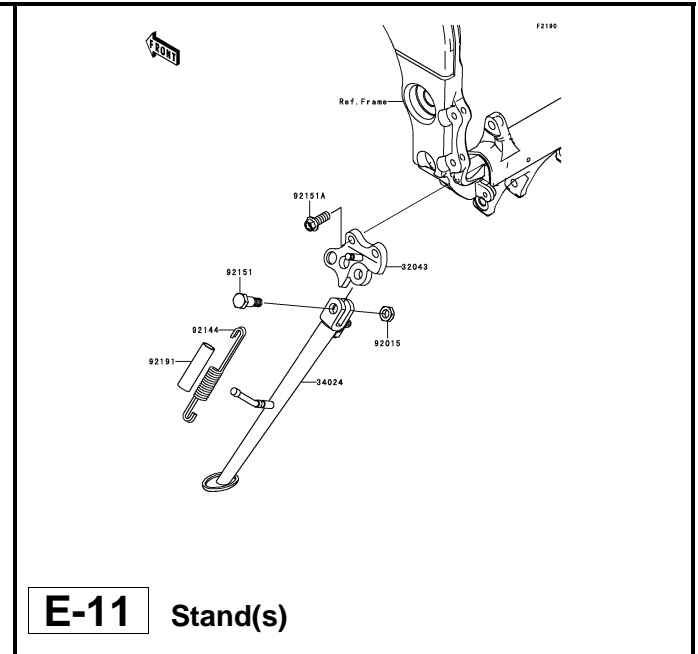
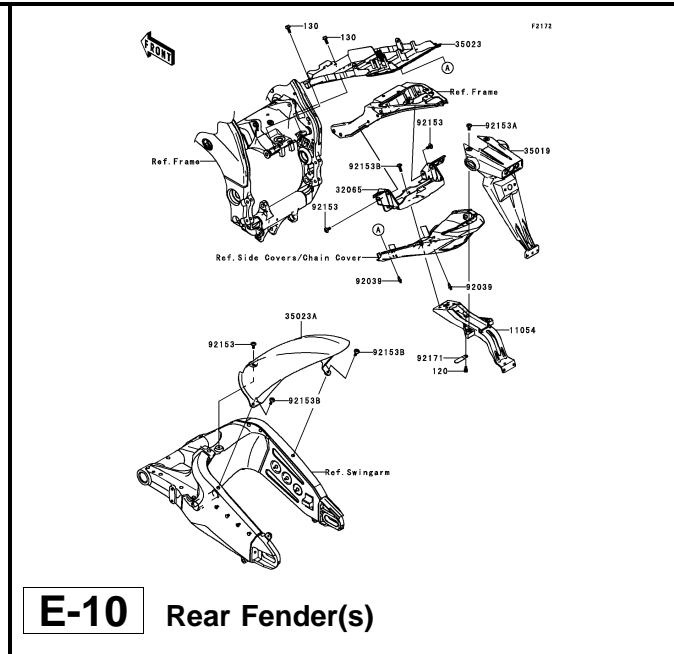
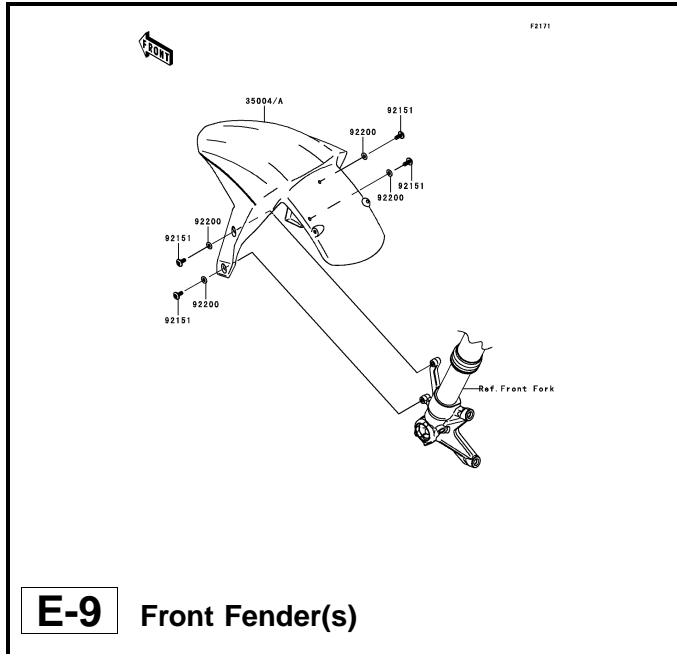

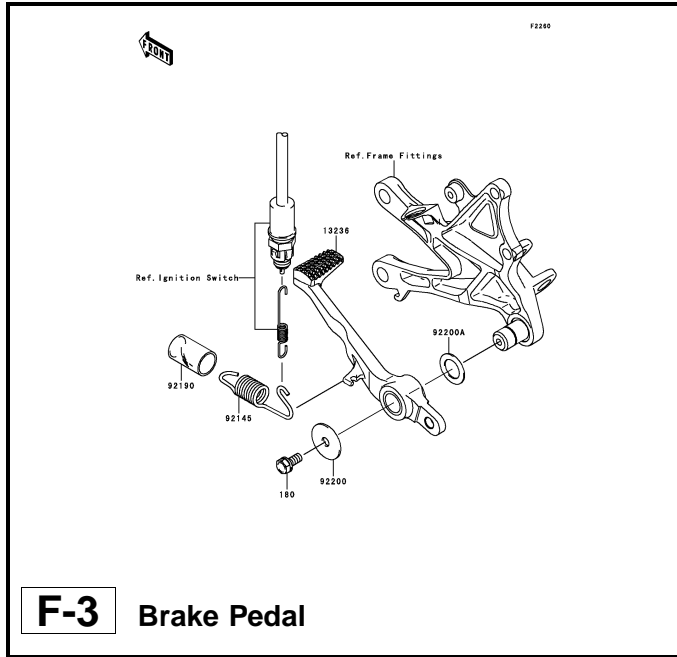

F-3 Brake Pedal

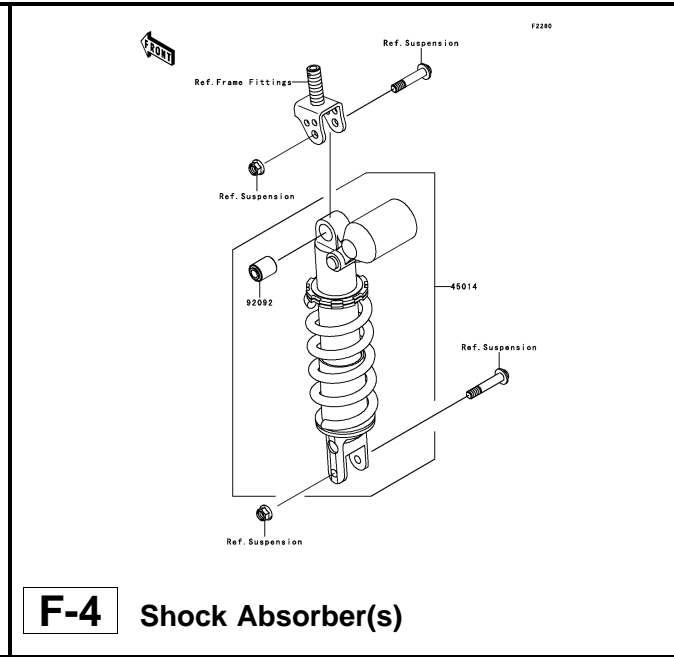

F-4 Shock Absorber(s)

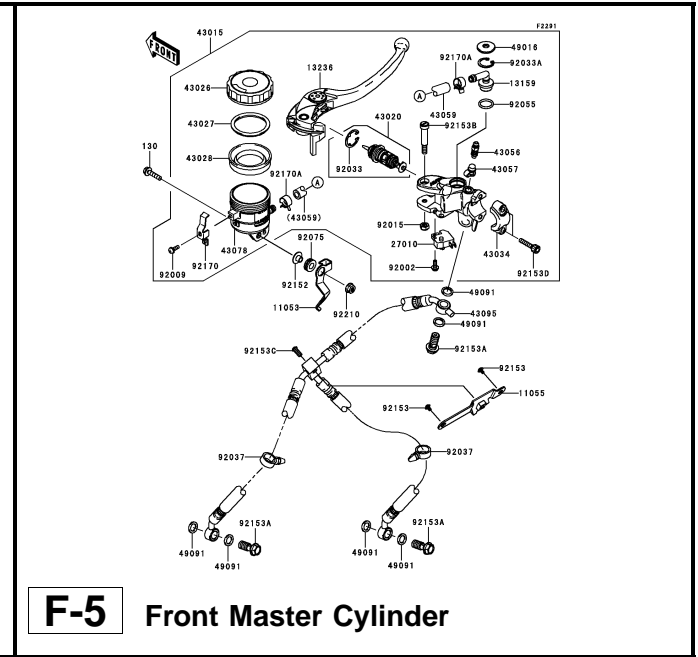

F-5 Front Master Cylinder

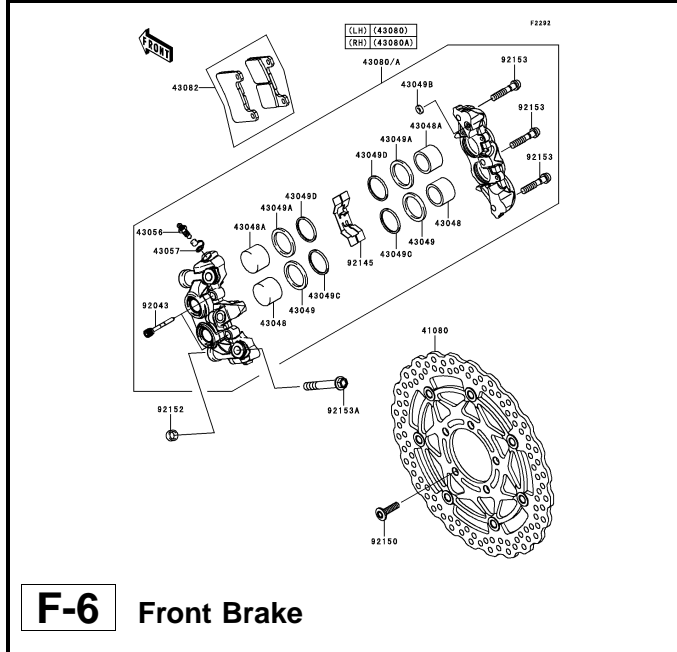

F-6 Front Brake

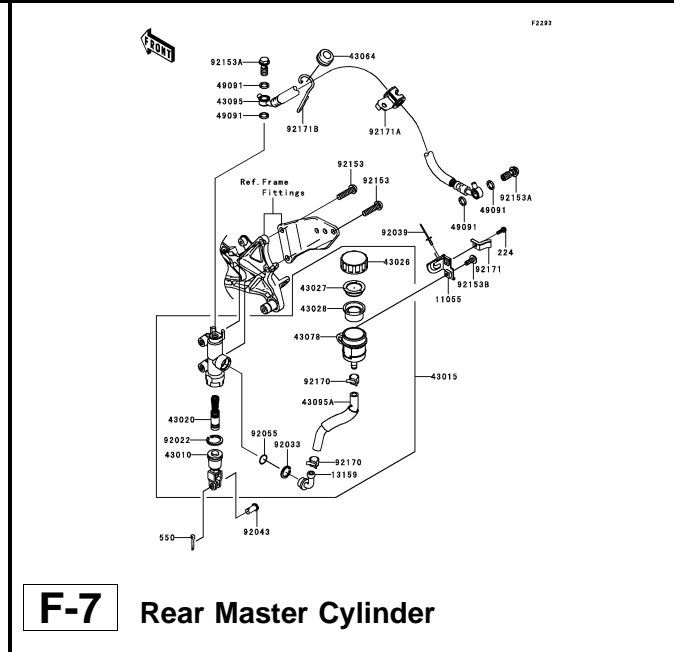

F-7 Rear Master Cylinder

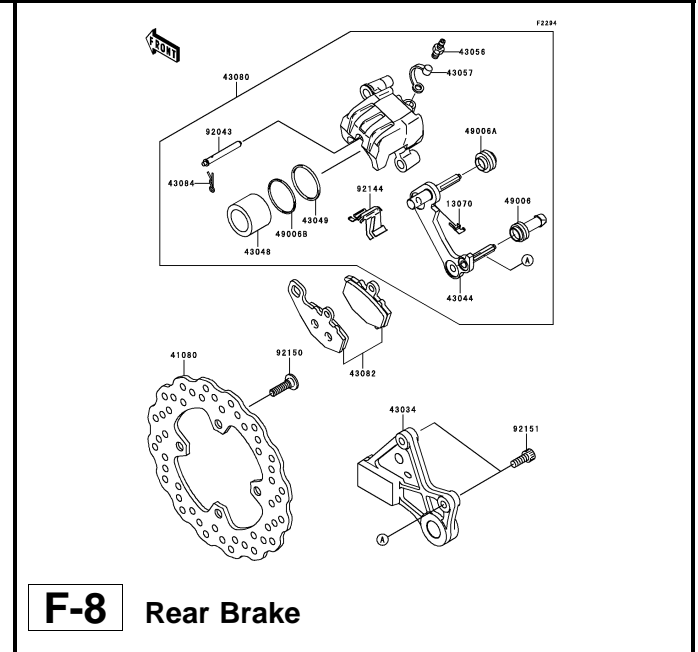

F-8 Rear Brake

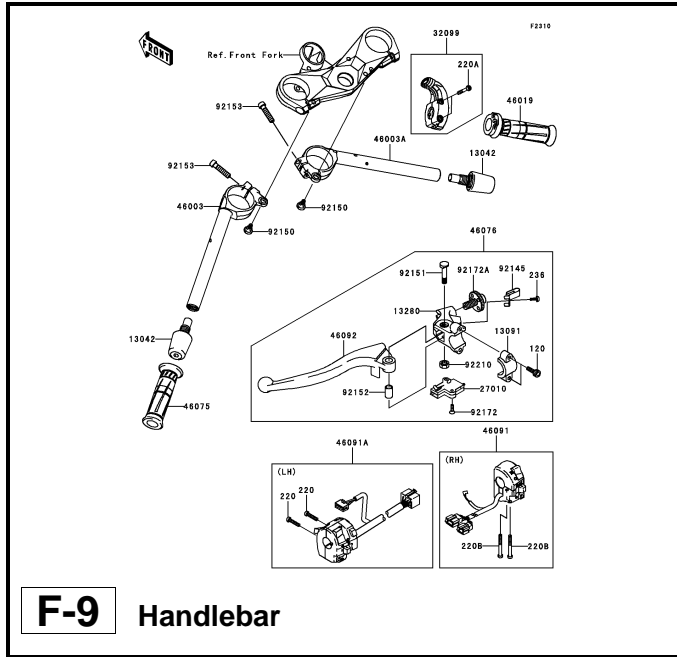

F-9 Handlebar

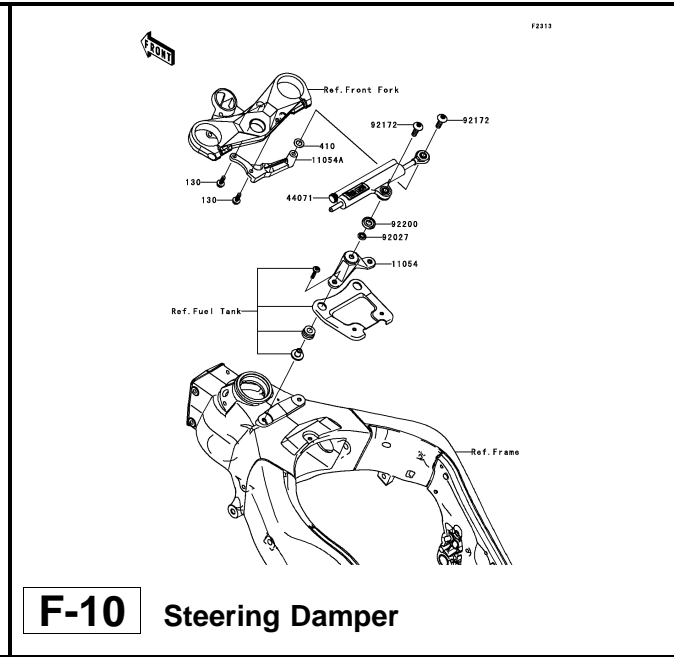

F-10 Steering Damper

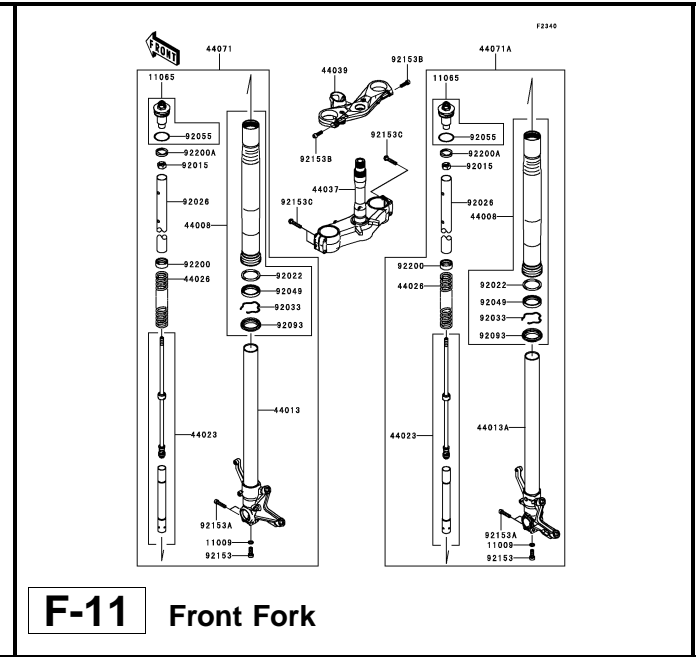

F-11 Front Fork

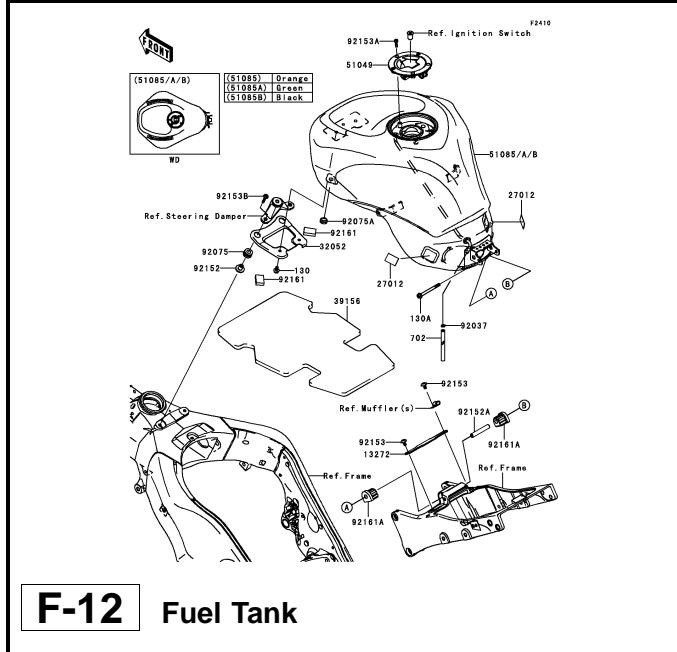

F-12 Fuel Tank

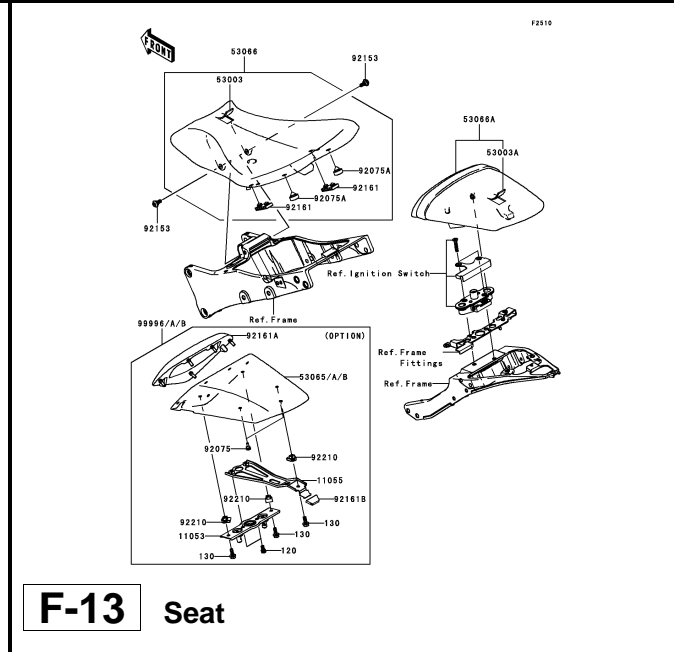

F-13 Seat

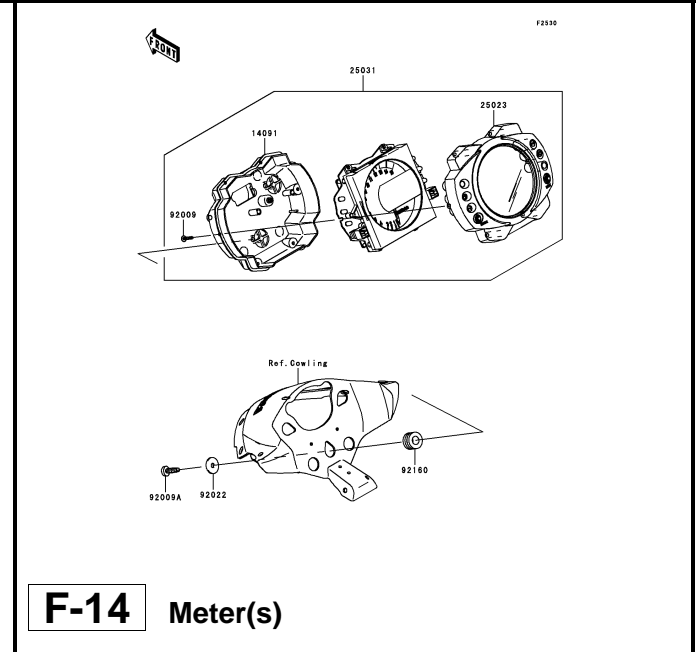

F-14 Meter(s)

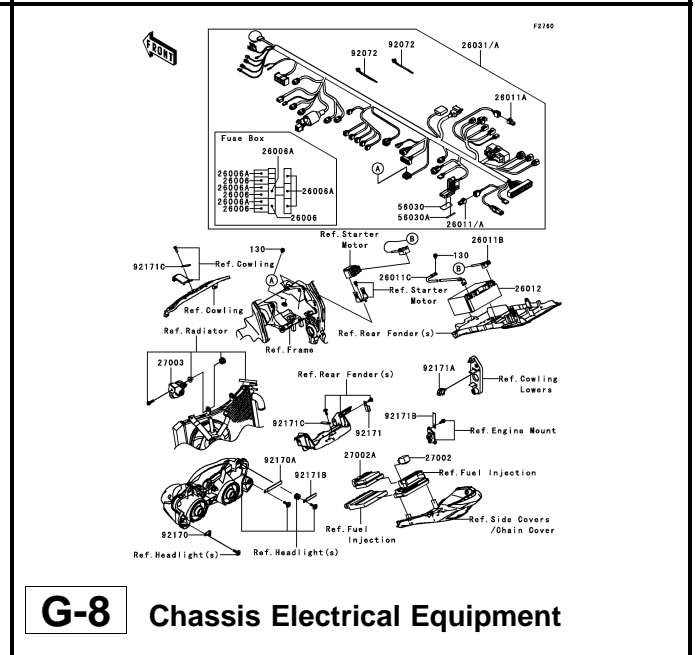
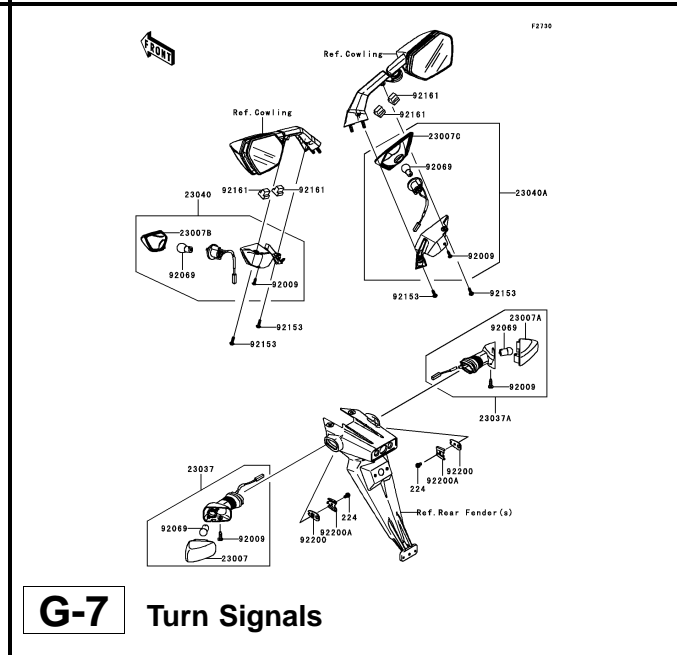
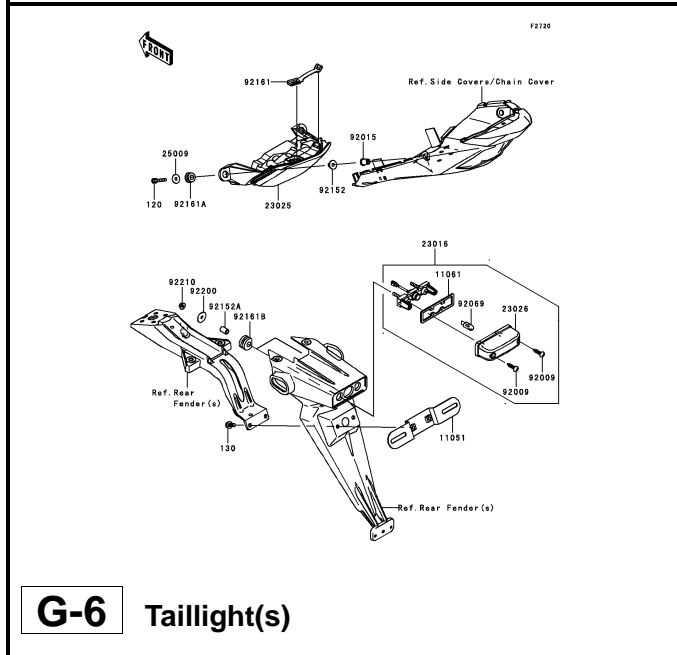
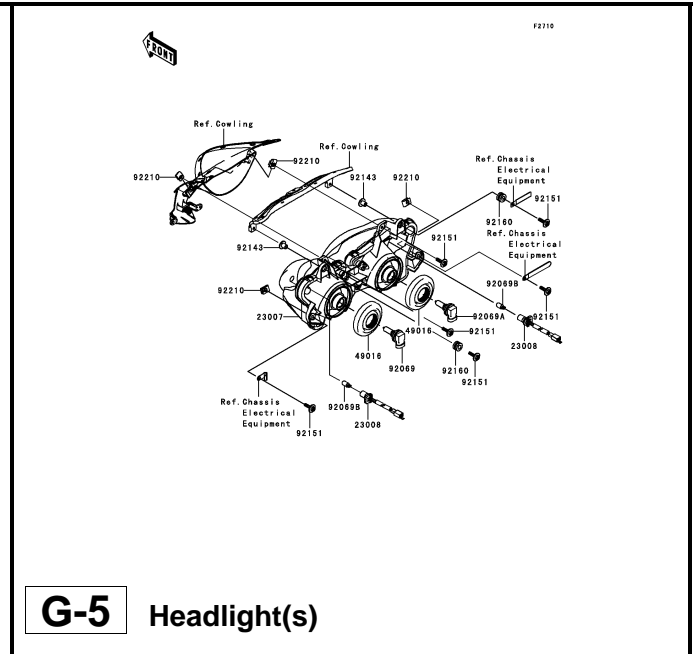
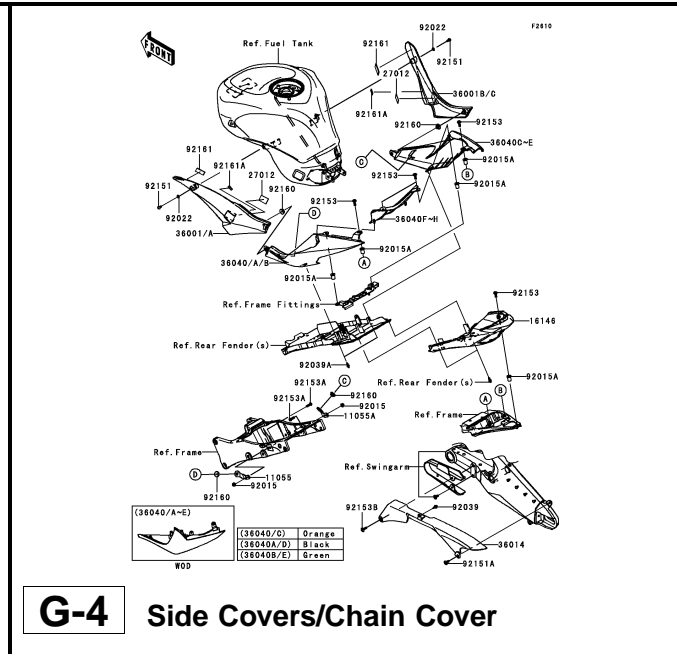
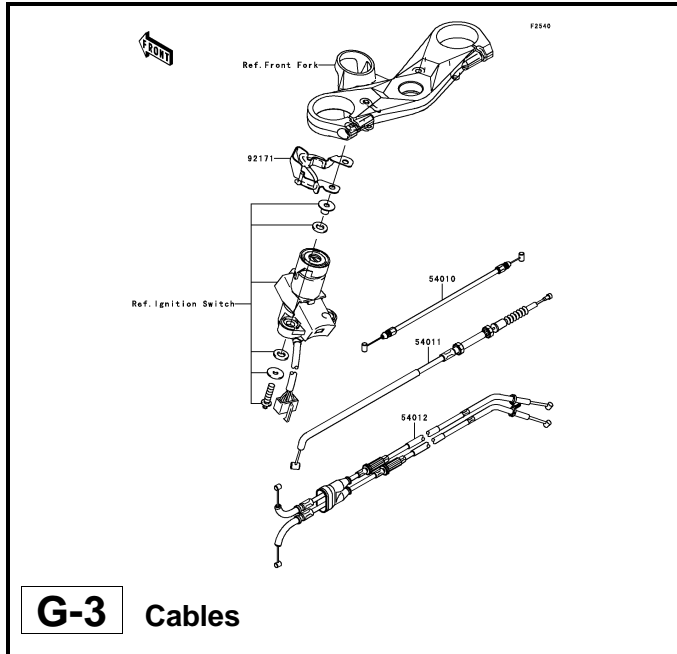

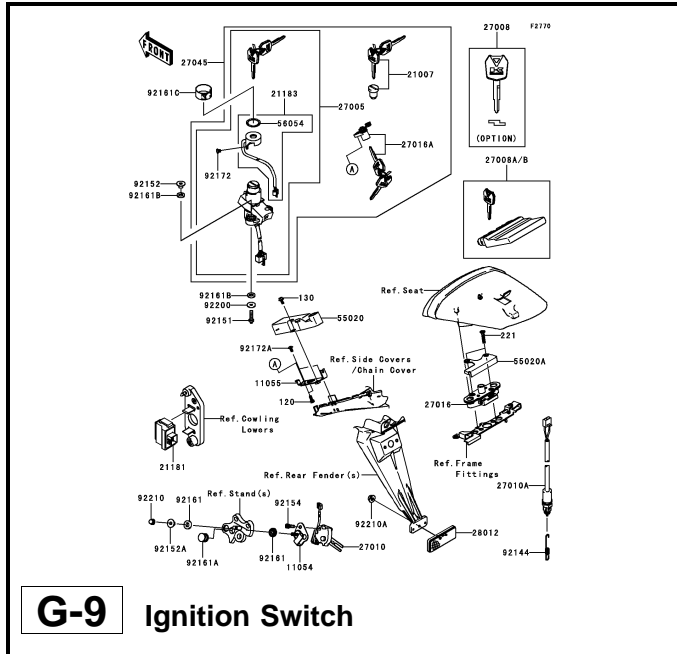

G-9 Ignition Switch

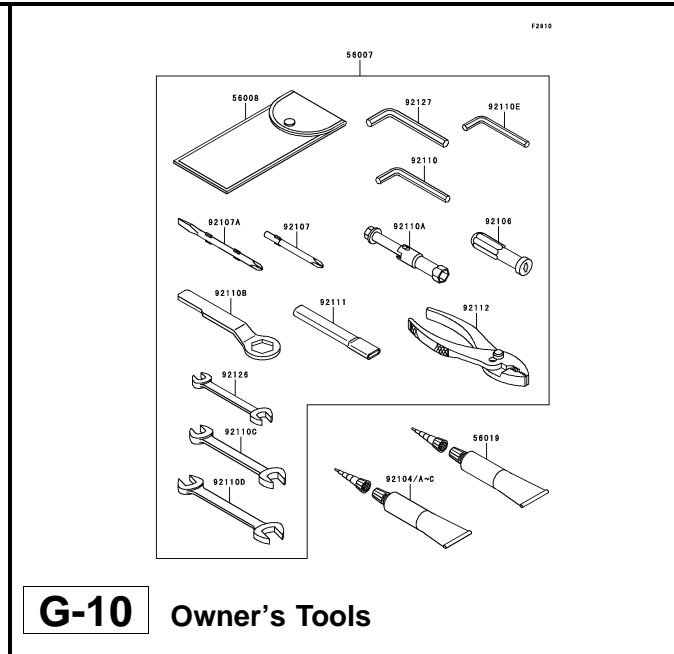

G-10 Owner's Tools

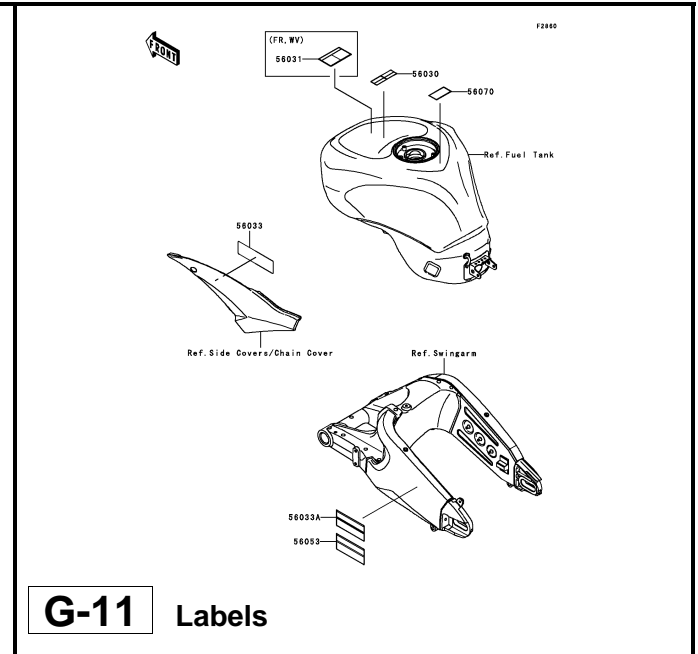

G-11 Labels

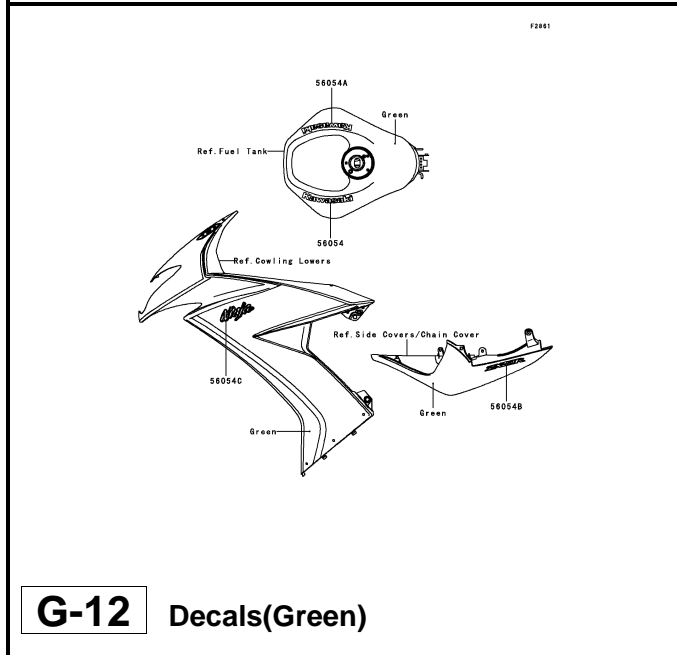

G-12 Decals(Green)

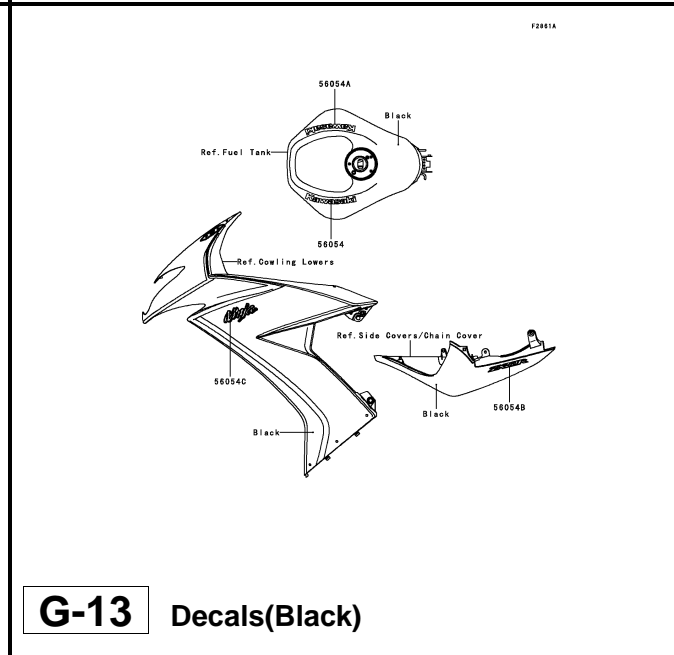

G-13 Decals(Black)

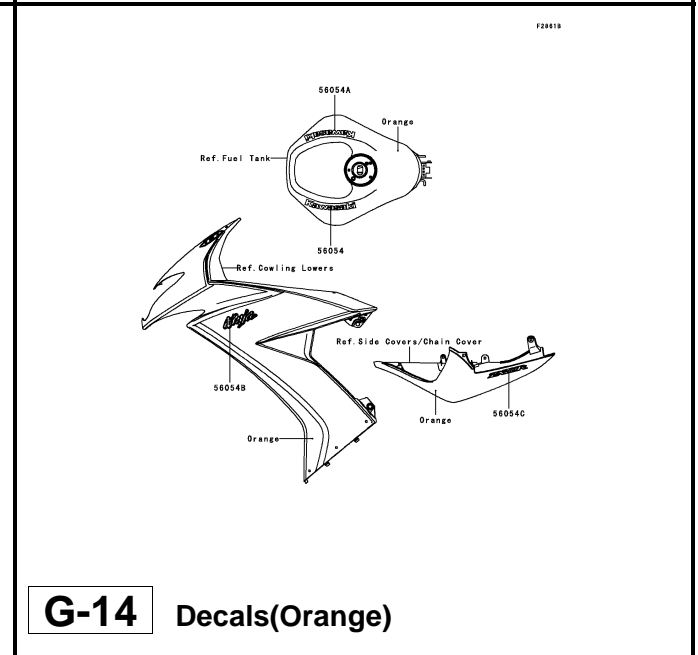

G-14 Decals(Orange)

This catalog covers:

'08 ZX1000E8F Chassis

GRID NO.

H-2

This grid covers:

Pictorial Index

This catalog covers:
'08 ZX1000E8F Engine

GRID NO. **B-3** This grid covers:
Cylinder Head

E1111

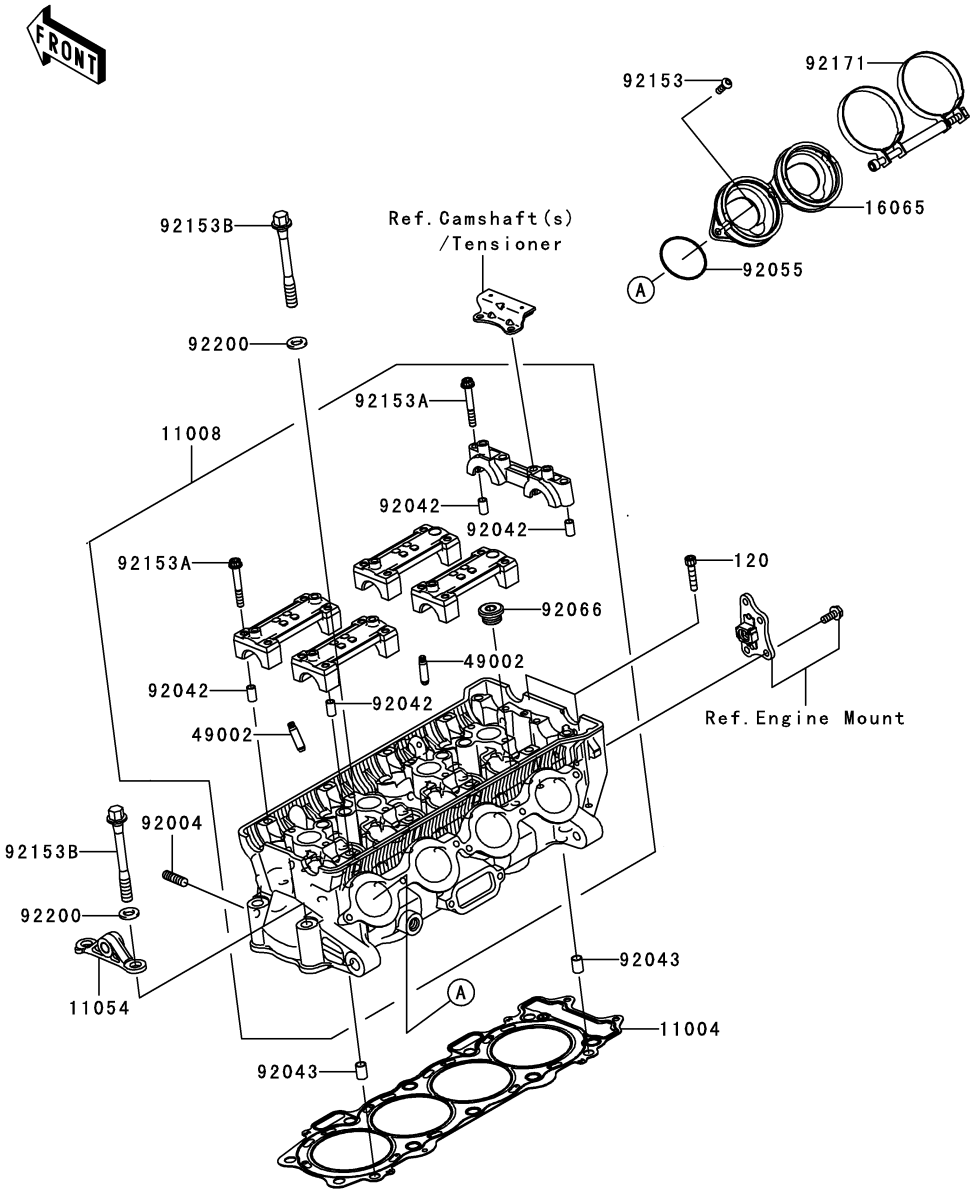

Ref. No.	Part No.	Description	Spec Code	Quantity-ZX1000		
				'08		
11004	11004-0081	GASKET-HEAD		1		
11008	11008-0130	HEAD-COMP-CYLINDER		1		
11054	11054-0488	BRACKET		1		
16065	16065-0052	HOLDER-CARBURETOR		2		
49002	49002-0009	GUIDE-VALVE		AR		
92004	92004-1186	STUD,8X18		8		
92042	92042-007	PIN,DOWEL,6.3X8X14		10		
92043	92043-1264	PIN,8.2X10X14		2		
92055	92055-1600	RING-O,47X1.9		4		
92066	92066-0016	PLUG,18X10		4		
92153	92153-0454	BOLT,TORX,6X18		6		
92153A	92153-0656	BOLT,SOCKET,6X45		20		
92153B	92153-0893	BOLT,FLANGED,10X90		10		
92171	92171-1610	CLAMP,64MM		2		
92200	92200-0114	WASHER,10.5X19X2.3		10		
120	120CD0630	BOLT-SOCKET,6X30		2		

This catalog covers:
'08 ZX1000E8F Engine

GRID NO.

B-4

This grid covers:
Cylinder Head Cover

E1112

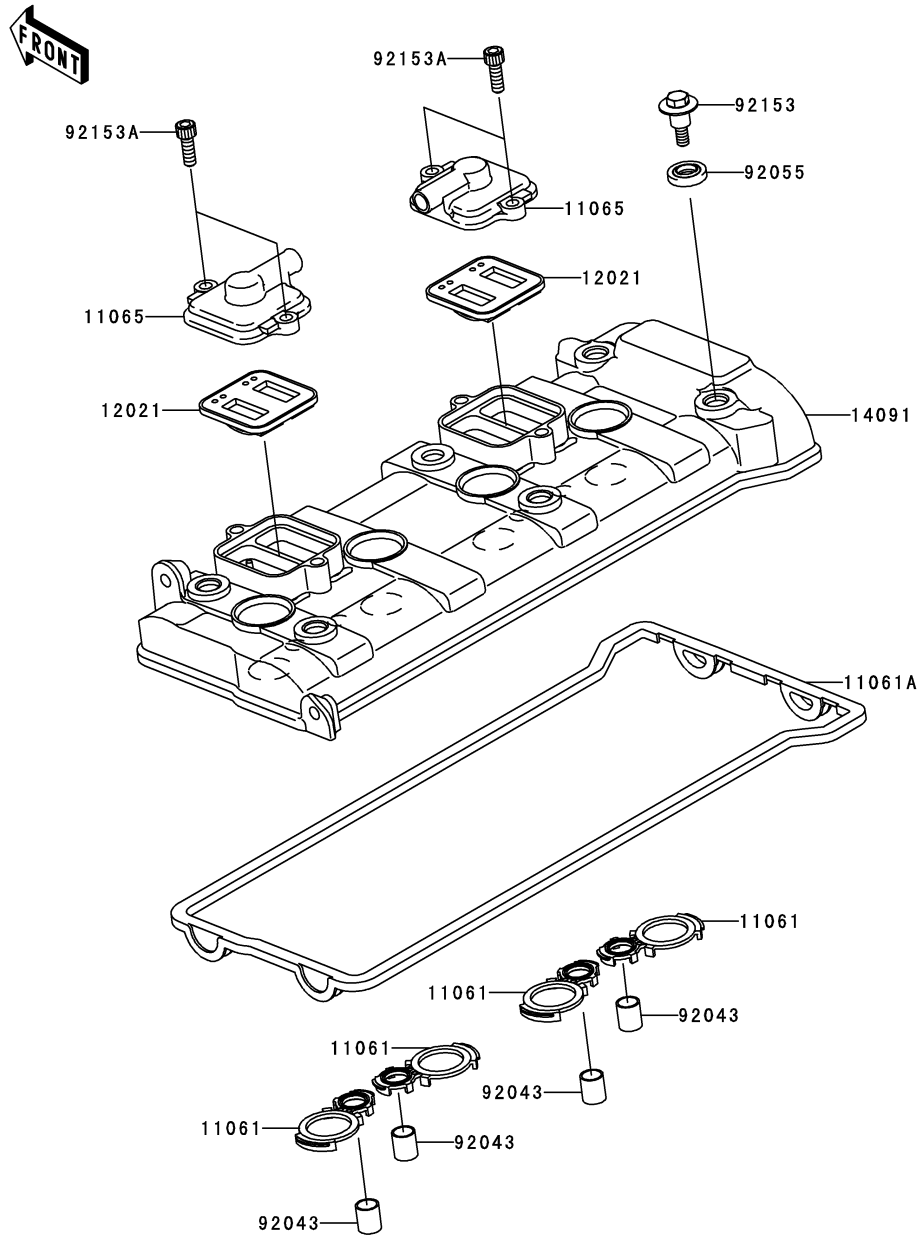

Ref. No.	Part No.	Description	Spec Code	Quantity-ZX1000			
				'08			
11061	11061-0064	GASKET,PLUG HOLE		4			
11061A	11061-0223	GASKET,HEAD COVER		1			
11065	11065-1247	CAP		2			
12021	12021-0020	VALVE-ASSY-REED		2			
14091	14091-0909	COVER,HEAD		1			
92043	92043-4009	PIN,10.1X12X14		4			
92055	92055-1352	RING-O,HEAD COVER BOLT		6			
92153	92153-1016	BOLT,FLANGED,6X22.5		6			
92153A	92153-1284	BOLT,SOCKET,6X18		4			

E1130

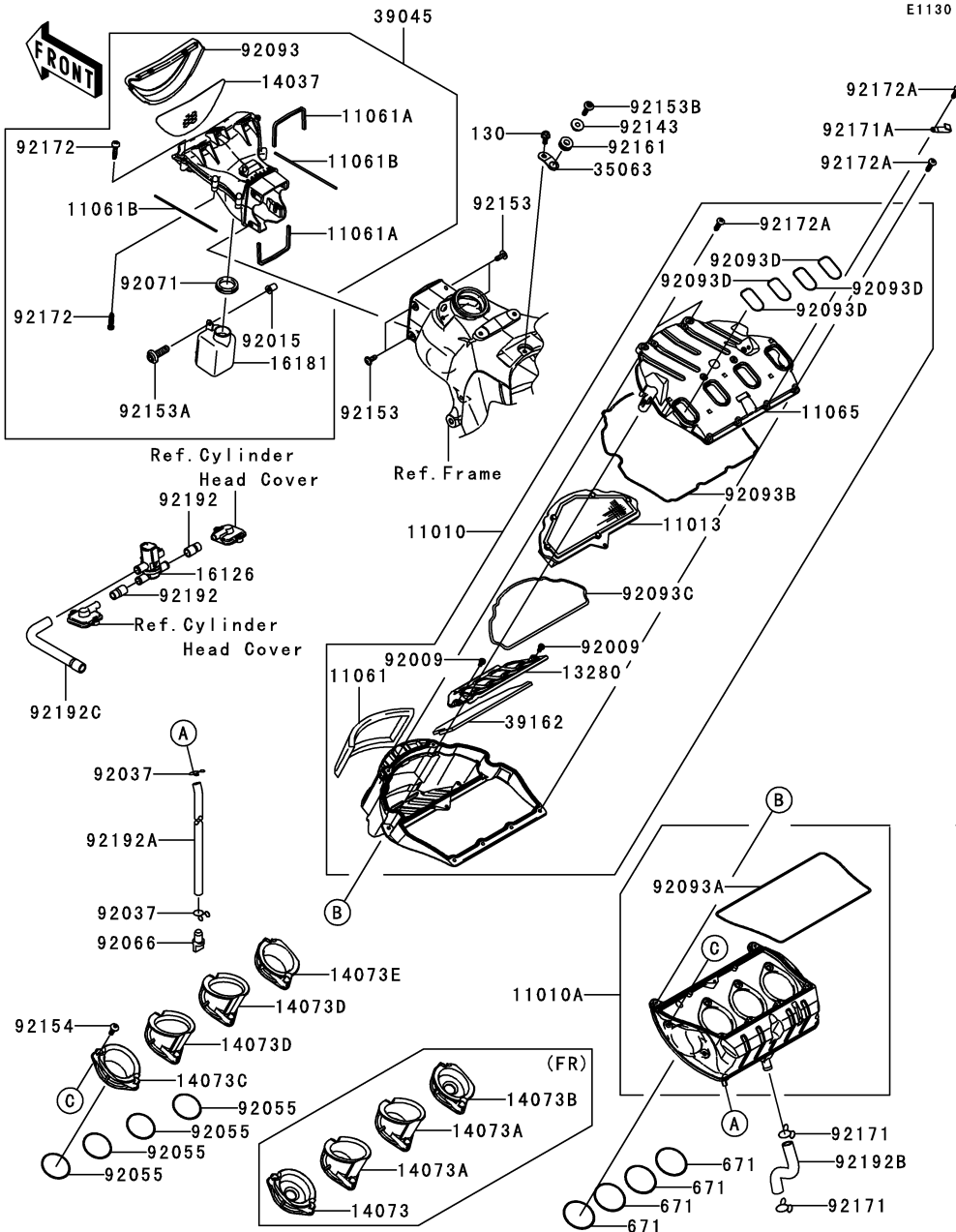

Ref. No.	Part No.	Description	Spec Code	Quantity-ZX1000	
				'08	E8F
11010	11010-0138	FILTER-ASSY-AIR,UPP			1
11010A	11010-0170	FILTER-ASSY-AIR,LWR			1
11013	11013-0026	ELEMENT-AIR FILTER			1
11061	11061-0309	GASKET			1
11061A	11061-0315	GASKET			2
11061B	11061-0316	GASKET			2
11065	11065-0225	CAP			1
13280	13280-0272	HOLDER,SILENCER			1
14037	14037-0077	SCREEN			1
14073	14073-0206	DUCT,FUNNEL,#1			1
		L-----	FR		1
14073A	14073-0207	DUCT,FUNNEL,#2			2
		L-----	FR		2
14073B	14073-0208	DUCT,FUNNEL,#4			1
		L-----	FR		1
14073C	14073-0231	DUCT,FUNNEL,#1			1
		L-----	UK,WV		1
14073D	14073-0232	DUCT,FUNNEL,#2			2
		L-----	UK,WV		2
14073E	14073-0233	DUCT,FUNNEL,#4			1
		L-----	UK,WV		1
16126	16126-0038	VALVE,AIR SWITCHING			1
16181	16181-0014	TANK-RESONATOR			1
35063	35063-0447	STAY			1
39045	39045-0035	DUCT-ASSY,RAM			1
39162	39162-0006	SILENCER-INTAKE			1
92009	92009-1499	SCREW,TAPPING,5X10			2
92015	92015-1757	NUT,WELL,5MM			1
92037	92037-147	CLAMP,TUBE			2
92055	92055-0156	RING-O			4
92066	92066-1211	PLUG,DRAIN			1
92071	92071-1137	GROMMET			1
92093	92093-0098	SEAL			1
92093A	92093-0108	SEAL,3X805			1
92093B	92093-0109	SEAL,3X925			1
92093C	92093-0110	SEAL,3X570			1
92093D	92093-0111	SEAL,3X152			4
92143	92143-1962	COLLAR			1
92153	92153-0875	BOLT,6X18			4
92153A	92153-1244	BOLT,SOCKET,5X16			1
92153B	92153-1356	BOLT,SOCKET,6X22			1

This catalog covers:
'08 ZX1000E8F Engine

GRID NO. **B-6** This grid covers:
Air Cleaner(2/2)

E1130

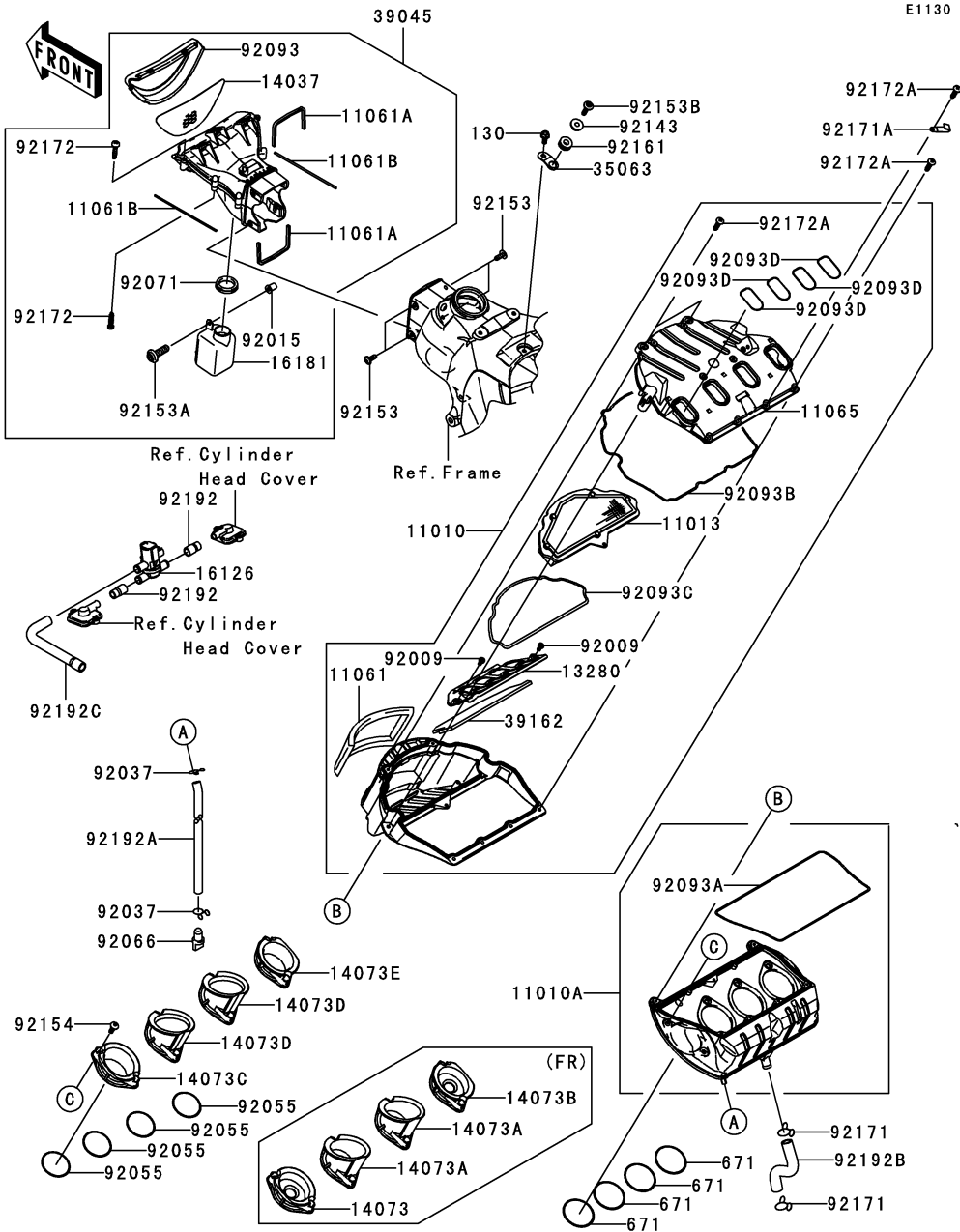

Ref. No.	Part No.	Description	Spec Code	Quantity-ZX1000	
				'08	E8F
92154	92154-0105	BOLT,SOCKET,5X17.7		8	
92161	92161-0154	DAMPER		1	
92171	92171-0391	CLAMP		2	
92171A	92171-1539	CLAMP		1	
92172	92172-0056	SCREW-PAN-CROS,5X25		6	
92172A	92172-0337	SCREW,TAPPING,5X25		9	
92192	92192-0033	TUBE,HEAD-ASV		2	
92192A	92192-0156	TUBE,7X10X500		1	
92192B	92192-0237	TUBE,BREATHER		1	
92192C	92192-0527	TUBE,ASV-A/C		1	
130	130AA0614	BOLT-FLANGED,6X14		1	
671	671E2565	O RING		4	

E1140

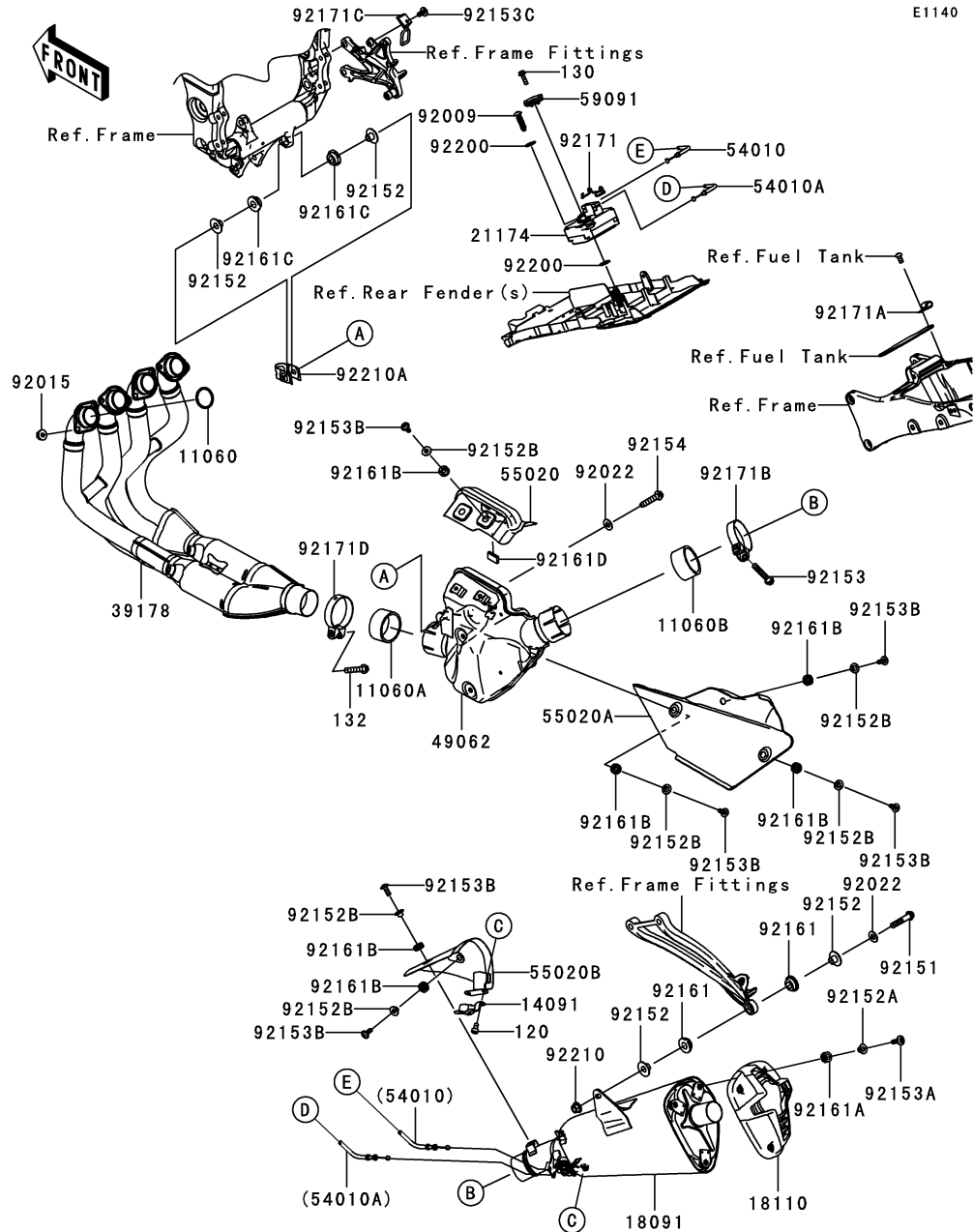

Ref. No.	Part No.	Description	Spec Code	Quantity-ZX1000		
				'08		
11060	11060-1103	GASKET,EXHAUST PIPE HOLDER			4	
11060A	11060-1376	GASKET,MUFFLER CONNECTING			1	
11060B	11060-1971	GASKET			1	
14091	14091-0915	COVER,PULLEY			1	
18091	18091-0549	BODY-COMP-MUFFLER			1	
18110	18110-0098	BODY END-MUFFLER			1	
21174	21174-0003	MOTOR-ELECTRIC			1	
39178	39178-0087	MANIFOLD-COMP-EXHAUST			1	
49062	49062-0040	PIPE-COMP-EXHAUST			1	
54010	54010-0105	CABLE,OPEN,WHITE			1	
54010A	54010-0106	CABLE,CLOSE,BLACK			1	
55020	55020-0467	GUARD,HEAT			1	
55020A	55020-0468	GUARD,EX CHAMBER			1	
55020B	55020-0488	GUARD,JOINT PIPE			1	
59091	59091-0007	PULLEY			1	
92009	92009-1481	SCREW,TAPPING,6X30			2	
92015	92015-1402	NUT,8MM			8	
92022	92022-3730	WASHER,8.5X19X1.2			2	
92151	92151-1532	BOLT,FLANGED,8X40			1	
92152	92152-0188	COLLAR			4	
92152A	92152-0237	COLLAR			3	
92152B	92152-0286	COLLAR			7	
92153	92153-0702	BOLT,8X45			1	
92153A	92153-0816	BOLT,6X18			3	
92153B	92153-0817	BOLT,SOCKET,6X16			7	
92153C	92153-1948	BOLT,SOCKET,6X12			1	
92154	92154-0080	BOLT,FLANGED,8X40			1	
92161	92161-0135	DAMPER			2	
92161A	92161-0204	DAMPER			3	
92161B	92161-0308	DAMPER			7	
92161C	92161-0658	DAMPER,MUFFLER MOUNT			2	
92161D	92161-1228	DAMPER			1	
92171	92171-0292	CLAMP			1	
92171A	92171-0652	CLAMP			1	
92171B	92171-1668	CLAMP,64.5MM			1	
92171C	92171-1871	CLAMP			1	
92171D	92171-1875	CLAMP			1	
92200	92200-0078	WASHER			4	
92210	92210-0121	NUT,8MM			1	
92210A	92210-0481	NUT			1	

This catalog covers:
'08 ZX1000E8F Engine

GRID NO. **B-8** This grid covers:
Muffler(s)(2/2)

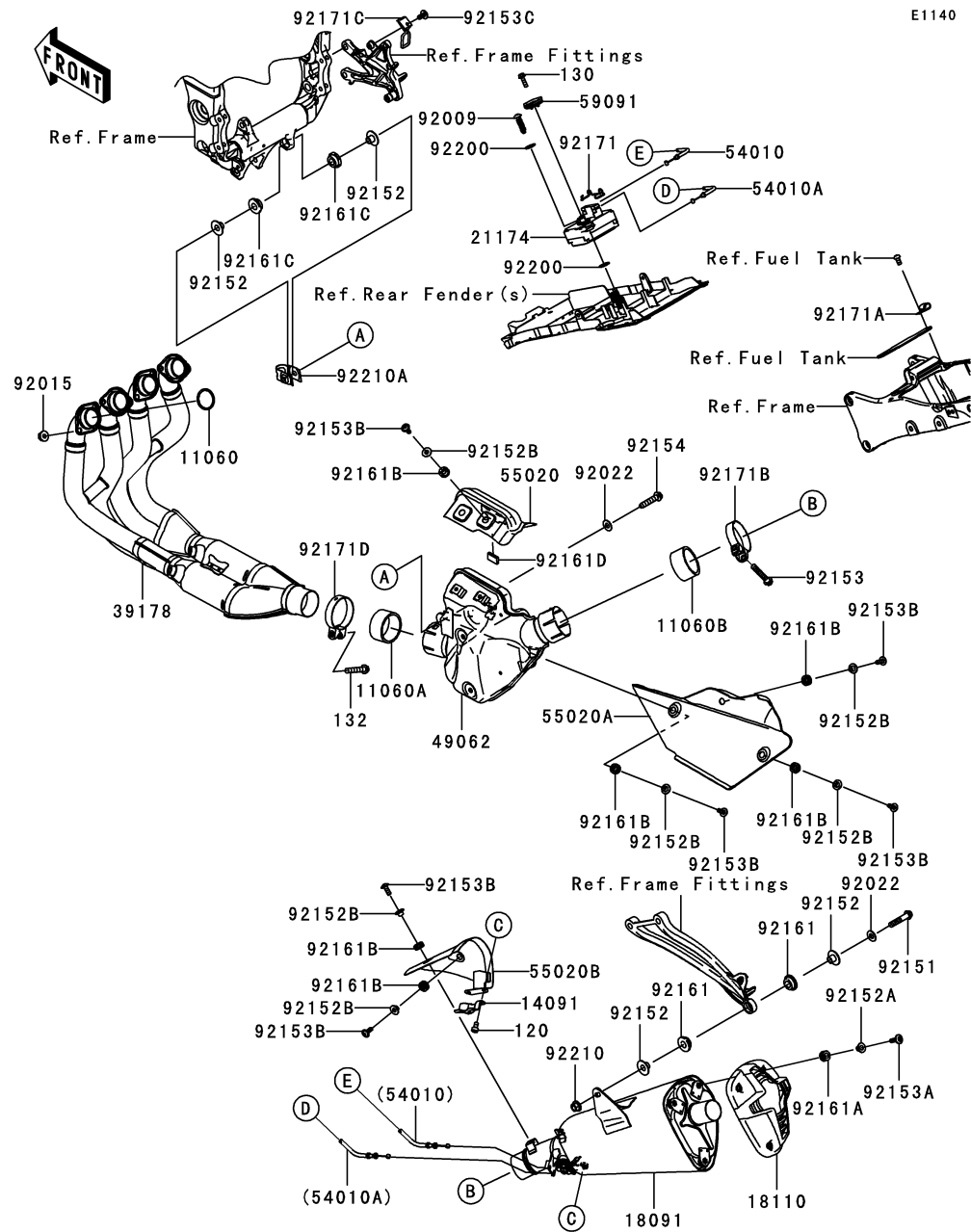

E1140

Ref. No.	Part No.	Description	Spec Code	Quantity-ZX1000	
				'08	E8F
120	120CB0610	BOLT-SOCKET,6X10		2	
130	130BB0518	BOLT-FLANGED,5X18		1	
132	132BC0830	BOLT-FLANGED-SMALL,8X30		1	

E1210

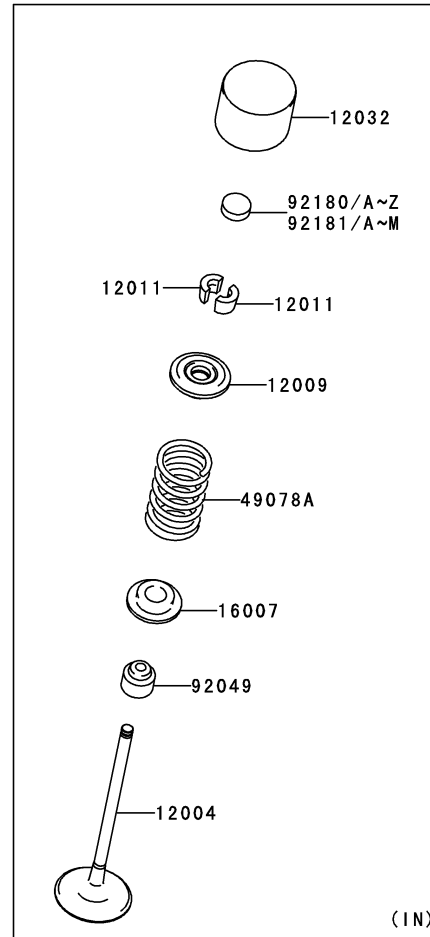
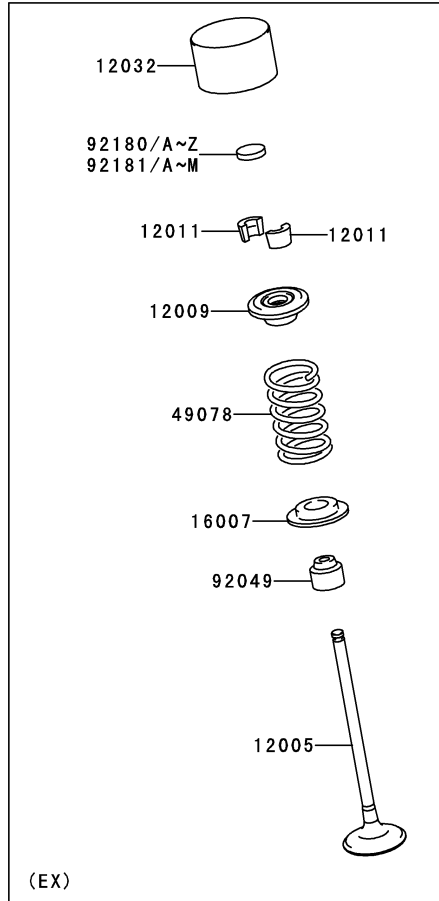

Ref. No.	Part No.	Description	Spec Code	Quantity-ZX1000			
				'08			
12004	12004-0035	VALVE-INTAKE		8			
12005	12005-0046	VALVE-EXHAUST		8			
12009	12009-0017	RETAINER-VALVE SPRING		16			
12011	12011-1053	COLLET		32			
12032	12032-0010	TAPPET		16			
16007	16007-0003	SEAT-SPRING		16			
49078	49078-0022	SPRING-ENGINE VALVE,EXHAUST		8			
49078A	49078-0066	SPRING-ENGINE VALVE,INTAKE		8			
92049	92049-1349	SEAL-OIL,VSB 4.3 7.5 5.3 8.3		16			
92180	92180-0108	SHIM,T=1.300		16			
92180A	92180-0109	SHIM,T=1.325		AR			
92180B	92180-0110	SHIM,T=1.350		AR			
92180C	92180-0111	SHIM,T=1.375		AR			
92180D	92180-0112	SHIM,T=1.400		AR			
92180E	92180-0113	SHIM,T=1.425		AR			
92180F	92180-0114	SHIM,T=1.450		AR			
92180G	92180-0115	SHIM,T=1.475		AR			
92180H	92180-0116	SHIM,T=1.500		AR			
92180I	92180-0117	SHIM,T=1.525		AR			
92180J	92180-0118	SHIM,T=1.550		AR			
92180K	92180-0119	SHIM,T=1.575		AR			
92180L	92180-0120	SHIM,T=1.600		AR			
92180M	92180-0121	SHIM,T=1.625		AR			
92180N	92180-0122	SHIM,T=1.650		AR			
92180O	92180-0123	SHIM,T=1.675		AR			
92180P	92180-0124	SHIM,T=1.700		AR			
92180Q	92180-0125	SHIM,T=1.725		AR			
92180R	92180-0126	SHIM,T=1.750		AR			
92180S	92180-0127	SHIM,T=1.775		AR			
92180T	92180-0128	SHIM,T=1.800		AR			
92180U	92180-0129	SHIM,T=1.825		AR			
92180V	92180-0130	SHIM,T=1.850		AR			
92180W	92180-0131	SHIM,T=1.875		AR			
92180X	92180-0132	SHIM,T=1.900		AR			
92180Y	92180-0133	SHIM,T=1.925		AR			
92180Z	92180-0134	SHIM,T=1.950		AR			
92181	92180-0135	SHIM,T=1.975		AR			
92181A	92180-0136	SHIM,T=2.000		AR			
92181B	92180-0137	SHIM,T=2.025		AR			
92181C	92180-0138	SHIM,T=2.050		AR			

E1210

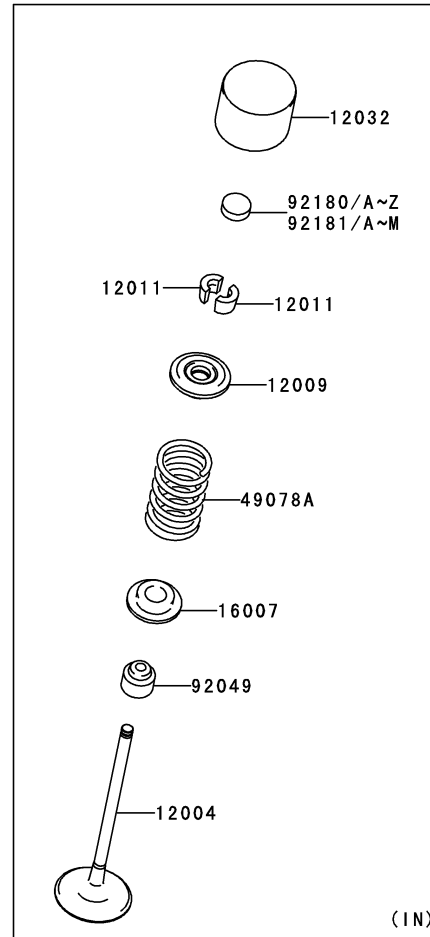
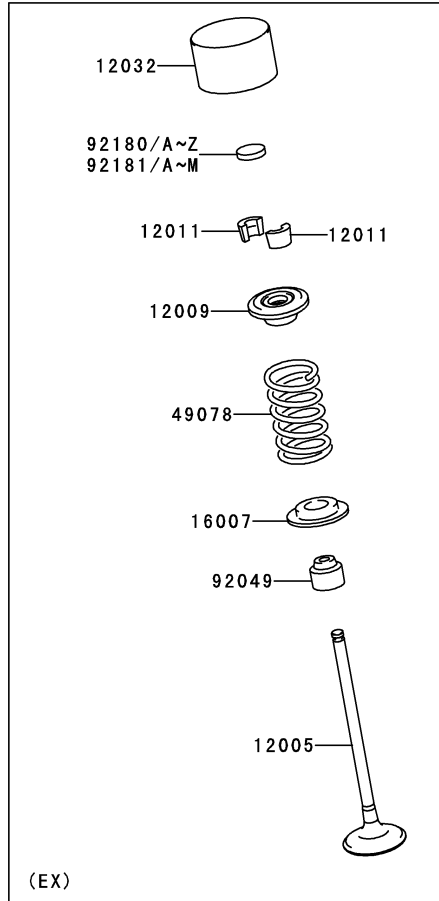

Ref. No.	Part No.	Description	Spec Code	Quantity-ZX1000			
				'08			
92181D	92180-0139	SHIM,T=2.075	AR				
92181E	92180-0140	SHIM,T=2.100	AR				
92181F	92180-0141	SHIM,T=2.125	AR				
92181G	92180-0142	SHIM,T=2.150	AR				
92181H	92180-0143	SHIM,T=2.175	AR				
92181I	92180-0144	SHIM,T=2.200	AR				
92181J	92180-0145	SHIM,T=2.225	AR				
92181K	92180-0146	SHIM,T=2.250	AR				
92181L	92180-0147	SHIM,T=2.275	AR				
92181M	92180-0148	SHIM,T=2.300	AR				

E1230

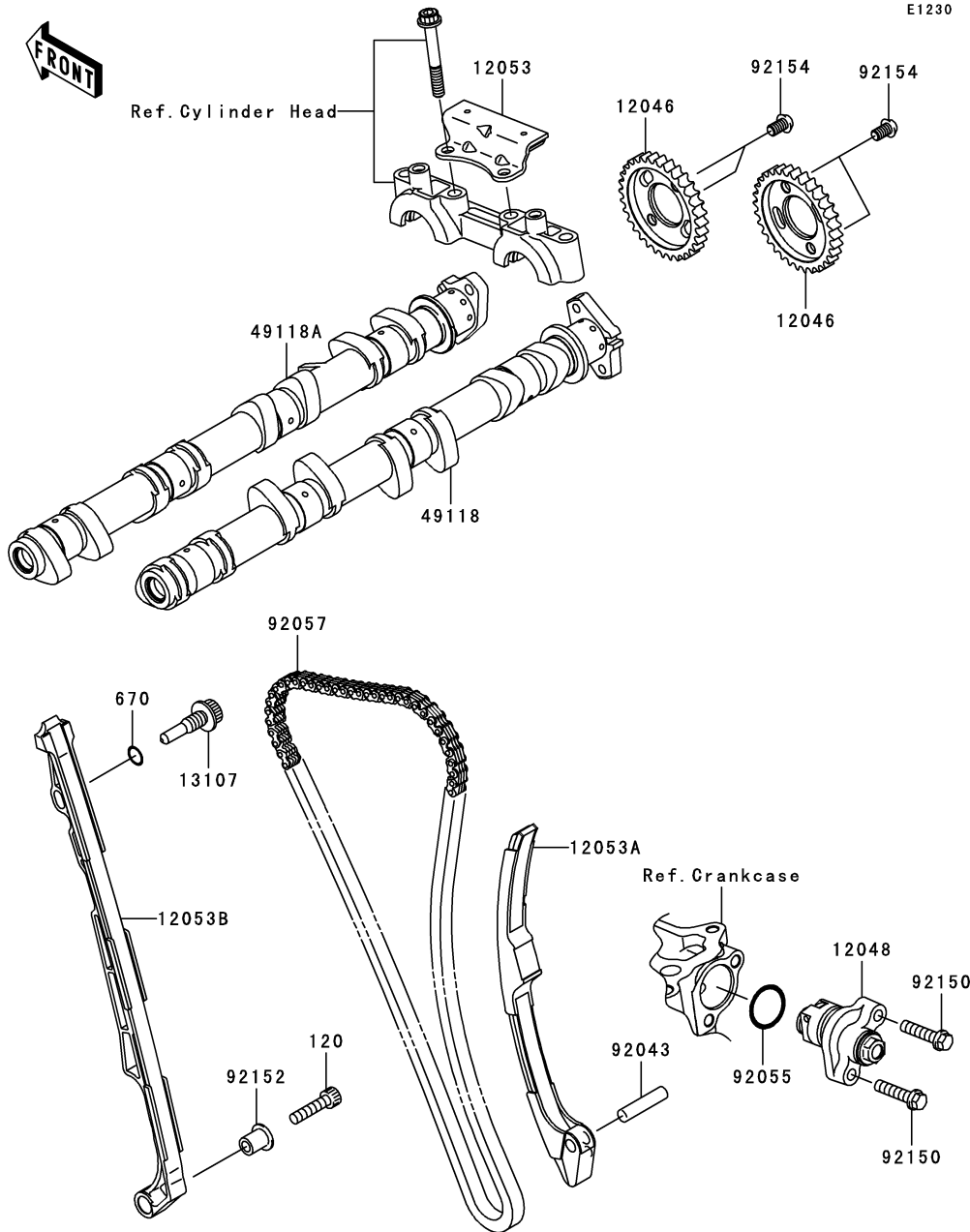

Ref. No.	Part No.	Description	Spec Code	Quantity-ZX1000	
				'08	E8F
12046	12046-0068	SPROCKET,32T		2	
12048	12048-0030	TENSIONER-ASSY		1	
12053	12053-0041	GUIDE-CHAIN,UPP		1	
12053A	12053-0050	GUIDE-CHAIN,RR		1	
12053B	12053-0062	GUIDE-CHAIN,FR		1	
13107	13107-0194	SHAFT,CHAIN GUIDE		1	
49118	49118-0116	CAMSHAFT-COMP,INTAKE		1	
49118A	49118-0117	CAMSHAFT-COMP,EXHAUST		1	
92043	92043-0062	PIN,7X30.7		1	
92055	92055-0053	RING-O,20.8X1.9		1	
92057	92057-0085	CHAIN,98XRH2015-124M		1	
92150	92150-1779	BOLT,FLANGED-SMALL,6X25		2	
92152	92152-0413	COLLAR		1	
92154	92154-0062	BOLT,TORX,6X10		4	
120	120CA0625	BOLT-SOCKET,6X25		1	
670	670D1509	O RING,9MM		1	

E1320

Ref. No.	Part No.	Description	Spec Code	Quantity-ZX1000			
				'08			
13001	13001-0098	PISTON-ENGINE		4			
13002	13002-0004	PIN-PISTON		4			
13008	13008-0005	RING-SET-PISTON		4			
13031	13031-0108	CRANKSHAFT-COMP		1			
13251	13251-0023-II	ROD-ASSY-CONNECTING,I		AR			
92015	92015-1311	NUT,FLANGED,8MM		8			
92033	92033-1054	RING-SNAP		8			
92139	92139-0032	BUSHING,CRANK #2,BLUE		AR			
92139A	92139-0033	BUSHING,CRANK #2,BLACK		4			
92139B	92139-0034	BUSHING,CRANK #2,BROWN		AR			
92139C	92139-0122	BUSHING,CRANK PIN,BLUE		AR			
92139D	92139-0123	BUSHING,CRANK PIN,BLACK		8			
92139E	92139-0124	BUSHING,CRANK PIN,BROWN		AR			
92139F	92139-0217	BUSHING,CRANK,#1,BLUE		AR			
92139G	92139-0218	BUSHING,CRANK,#1,BLACK		6			
92139H	92139-0219	BUSHING,CRANK,#1,BROWN		AR			
92153	92153-0809	BOLT,CON-ROD,M8X45.5		8			
92200	92200-0424	WASHER,T=3.25		2			

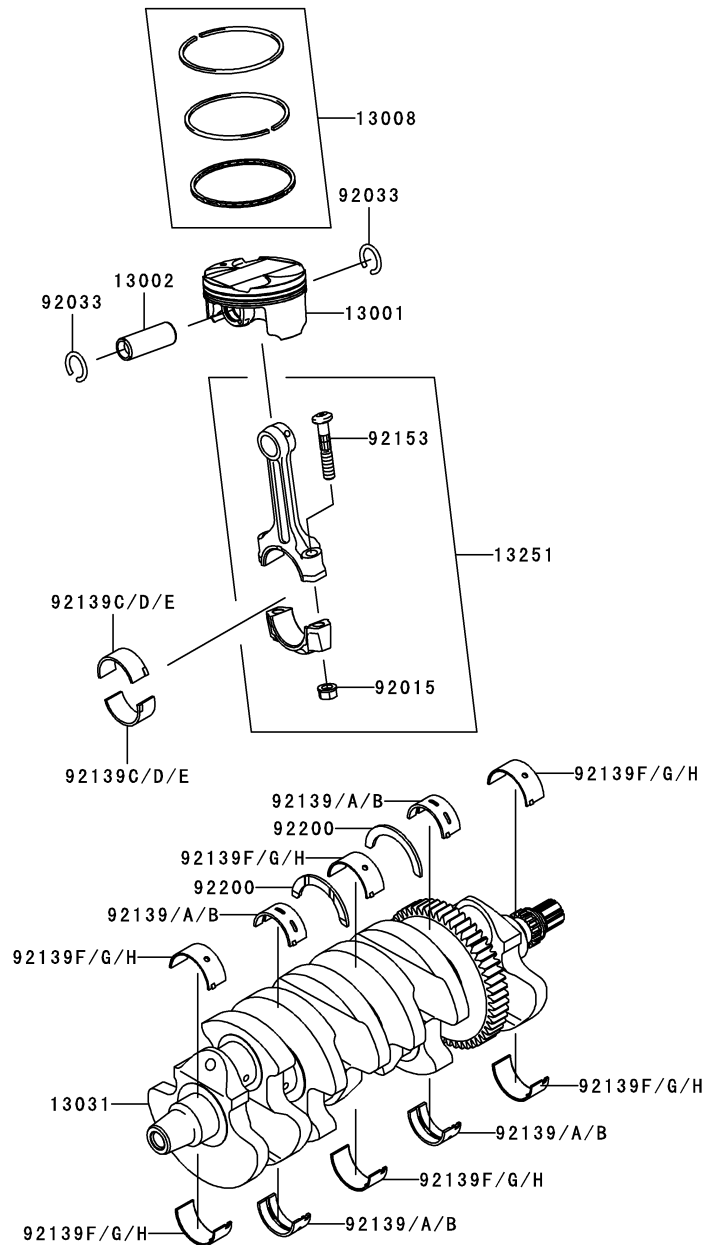

E1350

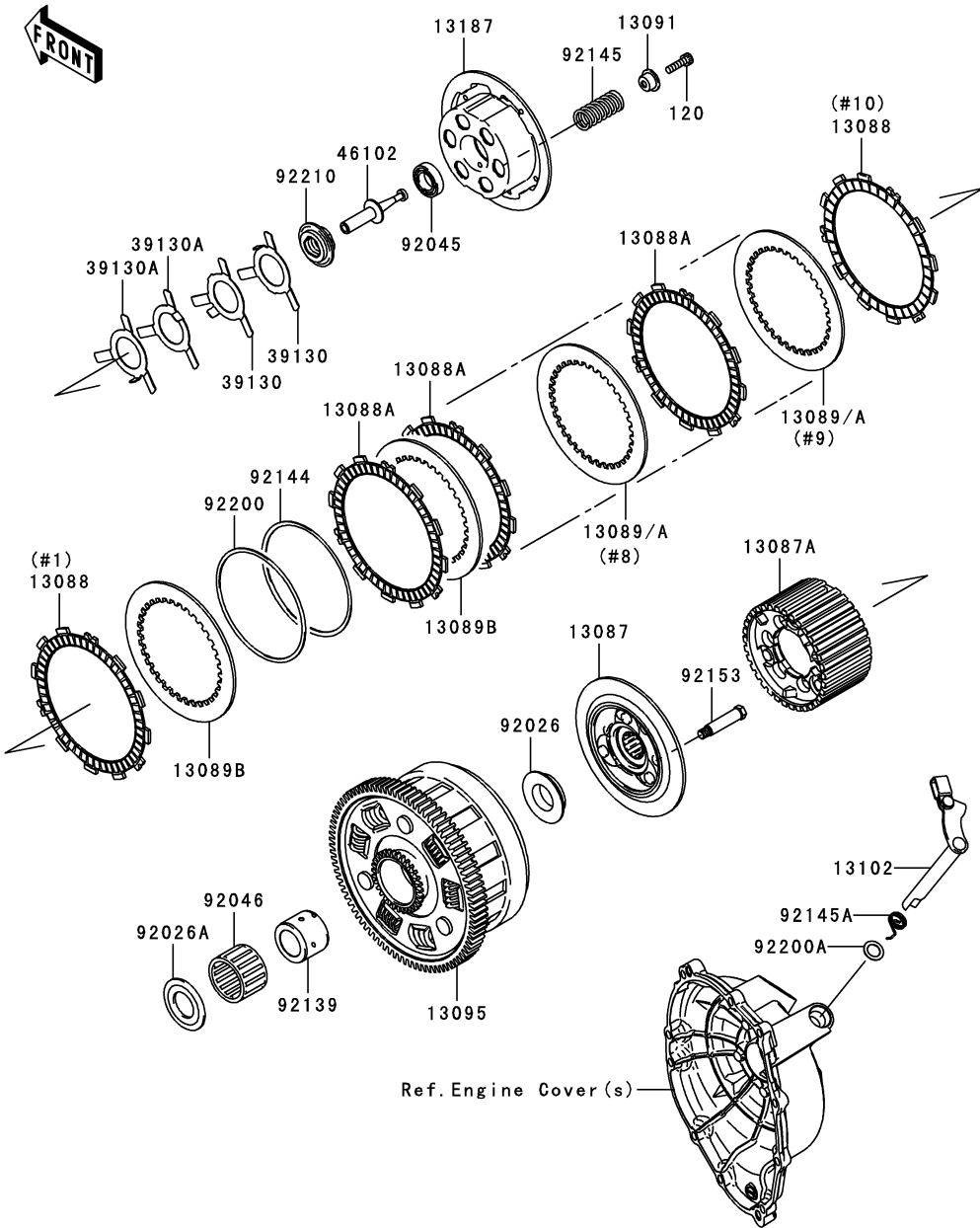

Ref. No.	Part No.	Description	Spec Code	Quantity-ZX1000		
				'08		
				E8F		
13087	13087-0010	HUB-CLUTCH			1	
13087A	13087-0011	HUB-CLUTCH			1	
13088	13088-0003	PLATE-FRICTION			2	
13088A	13088-0013	PLATE-FRICTION			8	
13089	13089-0008	PLATE-CLUTCH,T=2.3			AR	
13089A	13089-0009	PLATE-CLUTCH,T=2.6			2	
13089B	13089-1093	PLATE-CLUTCH,T=2.9			7	
13091	13091-1840	HOLDER,CLUTCH SPRING			6	
13095	13095-0080	HOUSING-COMP-CLUTCH			1	
13102	13102-0018	RELEASE-COMP-CLUTCH			1	
13187	13187-0006	PLATE-CLUTCH OPERATING			1	
39130	39130-1078	SPRING-LEAF			2	
39130A	39130-1079	SPRING-LEAF			2	
46102	46102-0047	ROD			1	
92026	92026-0037	SPACER			1	
92026A	92026-0119	SPACER,25X49X2.4			1	
92045	92045-1053	BEARING-BALL,6903/2A			1	
92046	92046-1263	BEARING-NEEDLE,K38X43X28.8X			1	
92139	92139-0067	BUSHING,25X38X29.05			1	
92144	92144-1854	SPRING,FRICTION PLATE			1	
92145	92145-0220	SPRING,CLUTCH			6	
92145A	92145-0325	SPRING,RELEASE-COMP			1	
92153	92153-0797	BOLT			6	
92200	92200-1260	WASHER,FRICTION PLATE			1	
92200A	92200-1487	WASHER,12X18.5X0.5			1	
92210	92210-0152	NUT			1	
120	120Q0620	BOLT-SOCKET,6X20			6	

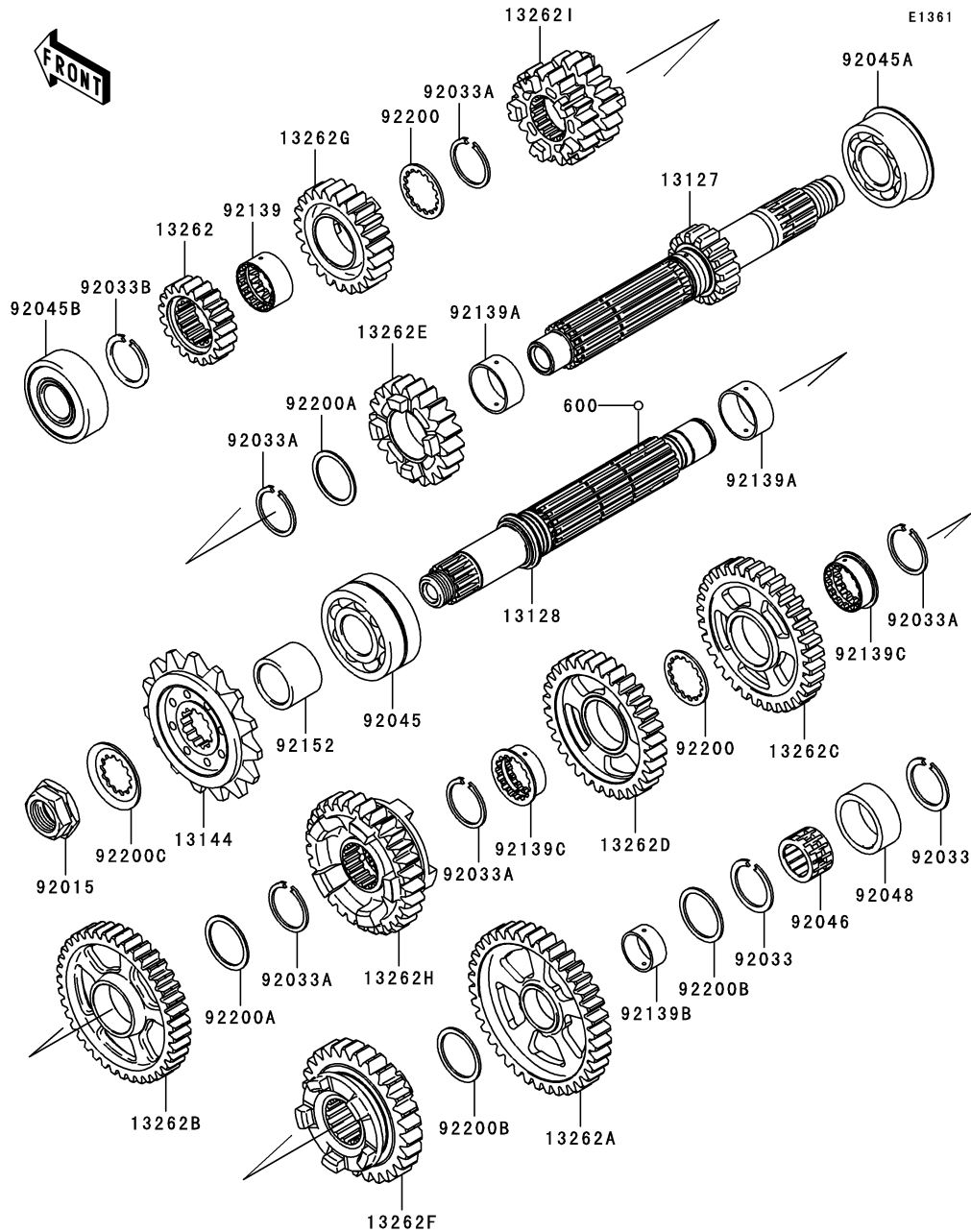

Ref. No.	Part No.	Description	Spec Code	Quantity-ZX1000			
				'08			
13127	13127-0060	SHAFT-TRANSMISSION INPUT		1			
13128	13128-0019	SHAFT-TRANSMISSION OUTPUT,13T		1			
13144	13144-0004	SPROCKET-OUTPUT,17T,#525		1			
13262	13262-0350	GEAR,INPUT 2ND,19T		1			
13262A	13262-0615	GEAR,OUTPUT LOW,39T		1			
13262B	13262-0616	GEAR,OUTPUT 2ND,39T		1			
13262C	13262-0618	GEAR,OUTPUT 3RD,33T		1			
13262D	13262-0619	GEAR,OUTPUT 4TH,31T		1			
13262E	13262-0620	GEAR,INPUT 5TH,20T		1			
13262F	13262-0621	GEAR,OUTPUT 5TH,28T		1			
13262G	13262-0622	GEAR,INPUT 6TH,23T		1			
13262H	13262-0623	GEAR,OUTPUT 6TH,30T		1			
13262I	13262-0665	GEAR,INPUT 3RD&4TH,19T&20T		1			
92015	92015-1963	NUT,20MM		1			
92033	92033-025	RING-SNAP,20X25.5X1.2		2			
92033A	92033-1037	RING-SNAP,25.9X30.6X1.2		5			
92033B	92033-1249	RING-SNAP,T=1.5		1			
92045	92045-0003	BEARING-BALL,DAC2557NSSH		1			
92045A	92045-0014	BEARING-BALL,5205N6RSH2CS6		1			
92045B	92045-0048	BEARING-BALL,DG2152RDDSH2		1			
92046	92046-1291	BEARING-NEEDLE		1			
92048	92048-1053	RACE,30X38X15		1			
92139	92139-0036	BUSHING,GEAR,6TH IN		1			
92139A	92139-0037	BUSHING,GEAR,5TH IN&2ND OUT		2			
92139B	92139-0038	BUSHING,GEAR,LOW OUT		1			
92139C	92139-0066	BUSHING,GEAR,3RD&4TH OUT		2			
92152	92152-0153	COLLAR		1			
92200	92200-0050	WASHER,28.3X34.0X1.6		2			
92200A	92200-0051	WASHER,28.1X34.0X1.2		2			
92200B	92200-0138	WASHER,22.1X32.0X1.4		2			
92200C	92200-1065	WASHER		1			
600	600A0500	BALL-STEEL,5/32"		3			

This catalog covers:
'08 ZX1000E8F Engine

GRID NO.

C-3

This grid covers:
Gear Change Drum/Shift Fork(s)

E1362

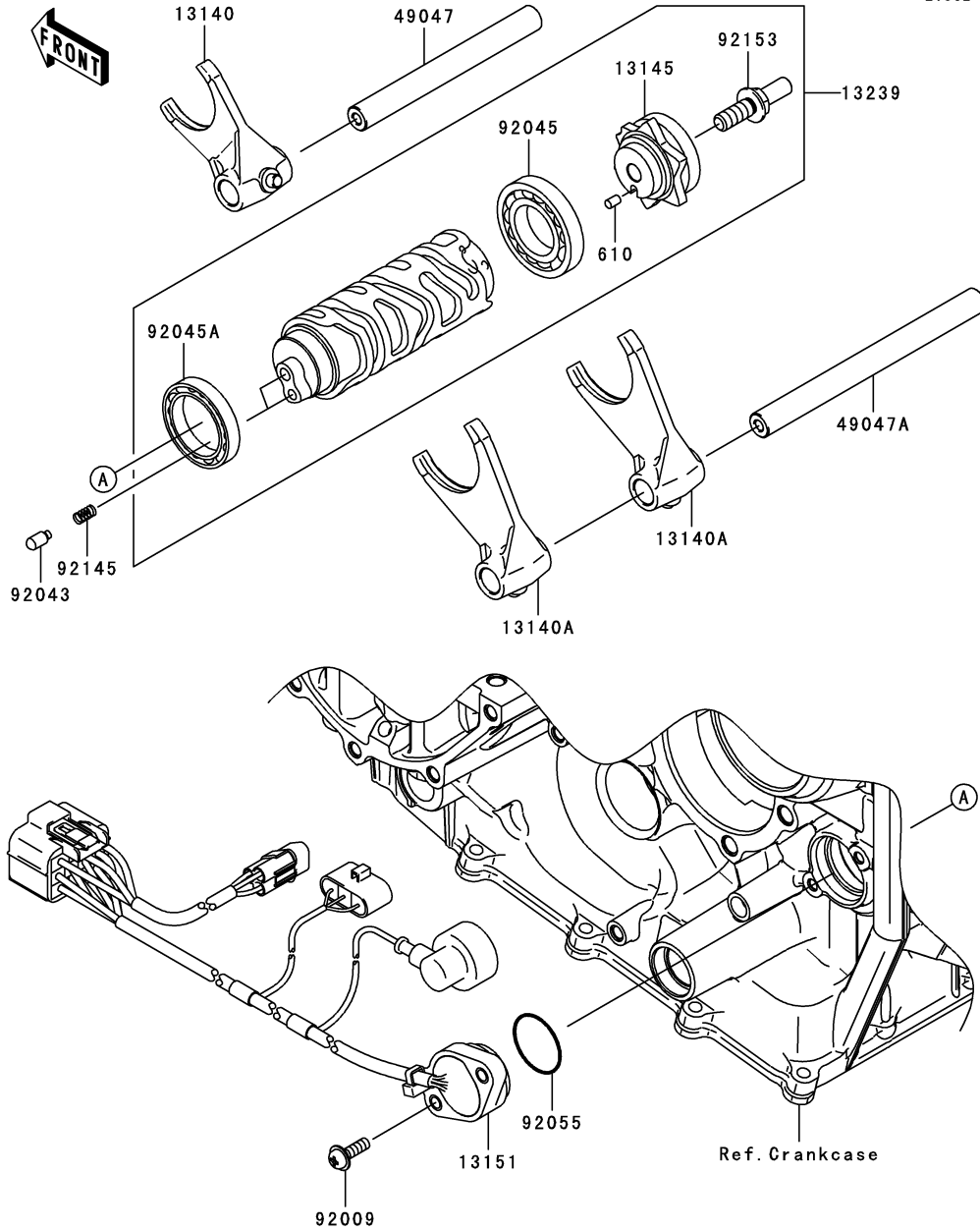

Ref. No.	Part No.	Description	Spec Code	Quantity-ZX1000	
				'08	E8F
13140	13140-0027	FORK-SHIFT,INPUT		1	
13140A	13140-0028	FORK-SHIFT,OUTPUT		2	
13145	13145-0039	CAM-CHANGE DRUM		1	
13151	13151-0044	SWITCH-COMP,NEUTRAL		1	
13239	13239-0030	DRUM-ASSY-CHANGE		1	
49047	49047-0021	ROD-SHIFT,INPUT		1	
49047A	49047-0022	ROD-SHIFT,OUTPUT		1	
92009	92009-1895	SCREW		2	
92043	92043-1654	PIN		2	
92045	92045-1045	BEARING-BALL,16005(NTN)		1	
92045A	92045-1152	BEARING-BALL,6806		1	
92055	92055-091	RING-O		1	
92145	92145-1414	SPRING		2	
92153	92153-1735	BOLT		1	
610	610A0406	ROLLER,4X6		1	

E1370

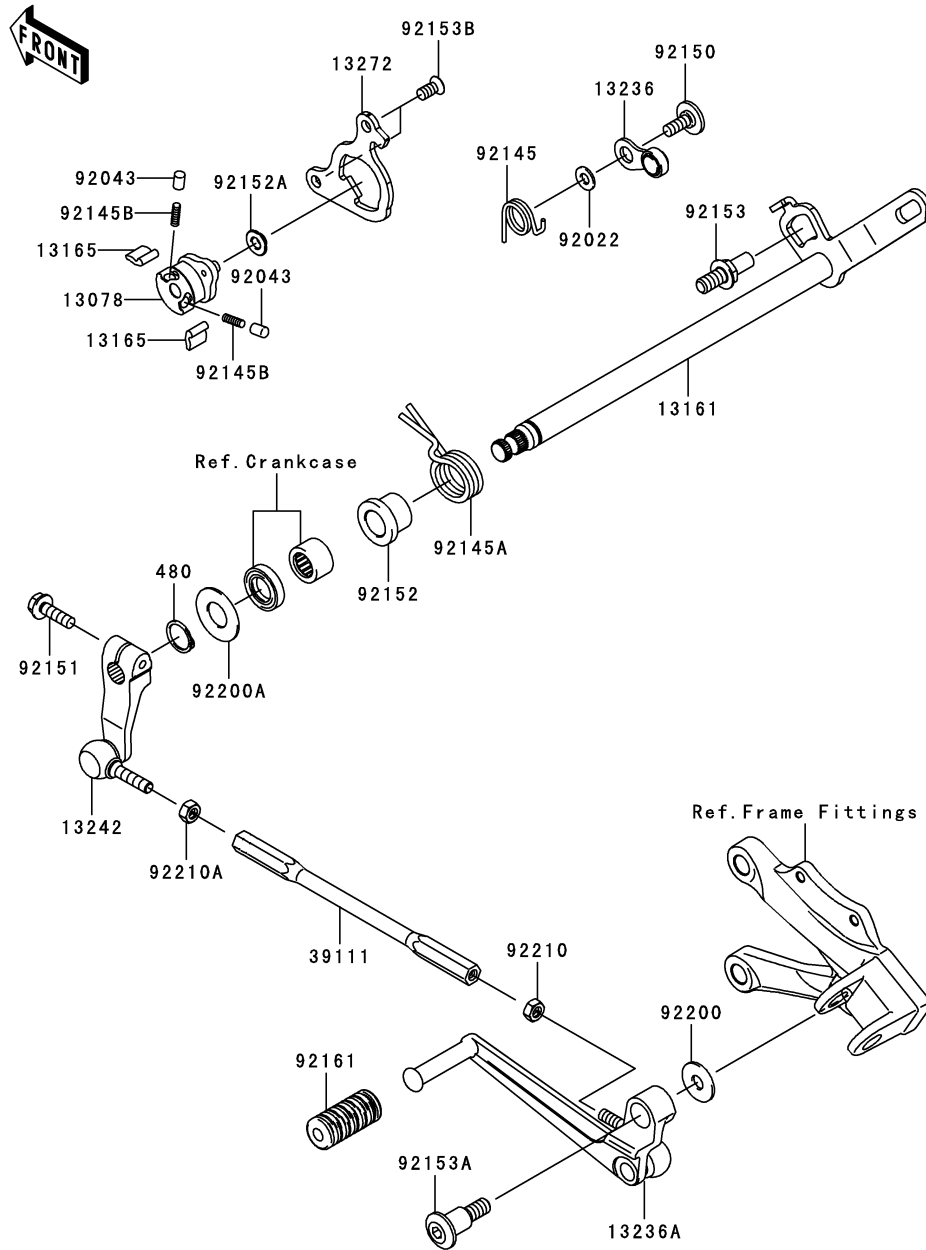

Ref. No.	Part No.	Description	Spec Code	Quantity-ZX1000	
				'08	E8F
13078	13078-0012	RATCHET			1
13161	13161-0061	LEVER-COMP-CHANGE SHAFT			1
13165	13165-0017	PAWL			2
13236	13236-0141	LEVER-COMP,POSITION			1
13236A	13236-0148	LEVER-COMP,CHANGE PEDAL			1
13242	13242-0052	LEVER-ASSY-CHANGE			1
13272	13272-0576	PLATE,PAWL GUIDE			1
39111	39111-0054	ROD-TIE,L=170			1
92022	92022-1827	WASHER,6X12.8X1.2			1
92043	92043-1676	PIN,PLUNGER			2
92145	92145-0629	SPRING			1
92145A	92145-0631	SPRING			1
92145B	92145-1490	SPRING			2
92150	92150-1673	BOLT,SOCKET,6X16			1
92151	92151-1226	BOLT,FLANGED,6X20			1
92152	92152-0720	COLLAR			1
92152A	92152-1414	COLLAR			1
92153	92153-0421	BOLT,RETURN SPRING			1
92153A	92153-0446	BOLT,SOCKET,M8X15.3X16.7			1
92153B	92153-1669	BOLT,TORX,6X8.7			2
92161	92161-1300	DAMPER,CHANGE PEDAL			1
92200	92200-0174	WASHER,8.0X22.0X1.5			1
92200A	92200-0265	WASHER			1
92210	92210-1100	NUT,6MM			1
92210A	92210-1101	NUT,LEFT HANDED,6MM			1
480	480J1400	CIRCLIP-TYPE-C,14MM			1

This catalog covers:
'08 ZX1000E8F Engine

GRID NO. **C-5** This grid covers:
Crankcase

E1411

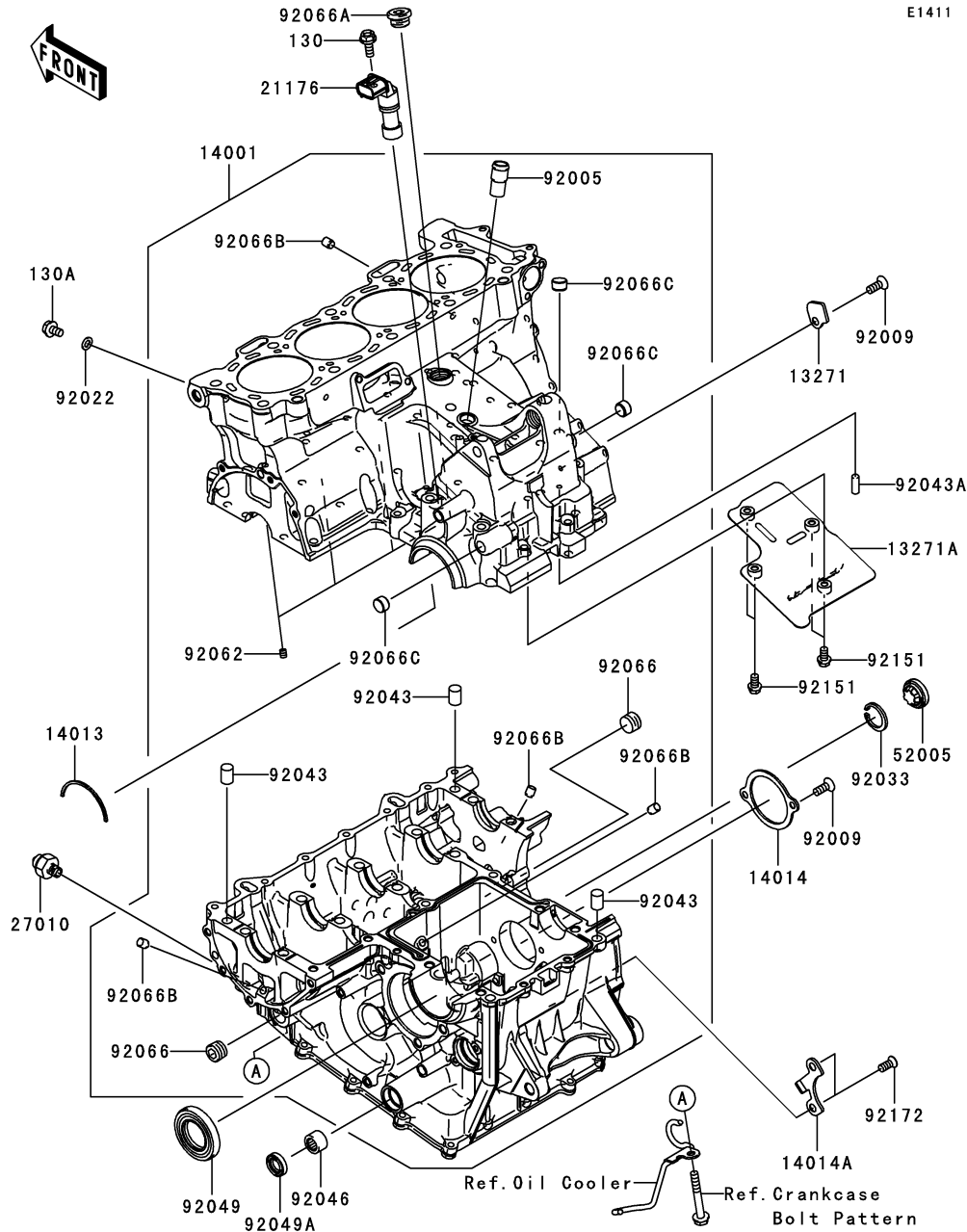

Ref. No.	Part No.	Description	Spec Code	Quantity-ZX1000	
				'08	E8F
13271	13271-0148	PLATE			1
13271A	13271-0594	PLATE,BREATHER ROOM			1
14001	14001-0121	SET-CRANKCASE			1
14013	14013-1051	RING-POSITION			1
14014	14014-0012	PLATE-POSITION			1
14014A	14014-0021	PLATE-POSITION			1
21176	21176-0042	SENSOR,SPEED			1
27010	27010-1313	SWITCH,OIL PRESSURE			1
52005	52005-1120	GAUGE			1
92005	92005-1238	FITTING,BREATHER			1
92009	92009-1360	SCREW,6X16			3
92022	92022-304	WASHER,6.2X11X1			1
92033	92033-1305	RING-SNAP			1
92043	92043-1506	PIN,10X14			3
92043A	92043-1690	PIN,6X16			1
92046	92046-037	BEARING-NEEDLE,7E-HK1412			1
92049	92049-1474	SEAL-OIL,TC32578			1
92049A	92049-1520	SEAL-OIL,TC14245			1
92062	92062-0004	NOZZLE			4
92066	92066-0003	PLUG,PT3/8X10			2
92066A	92066-0016	PLUG,18X10			1
92066B	92066-1012	PLUG,OIL LINE,7.2X8			4
92066C	92066-1110	PLUG			3
92151	92151-1389	BOLT,FLANGED-SMALL,6X10			4
92172	92172-0384	SCREW,TORX,6X14			2
130	130BB0616	BOLT-FLANGED,6X16			1
130A	130BD0610	BOLT-FLANGED,6X10			1

E1412

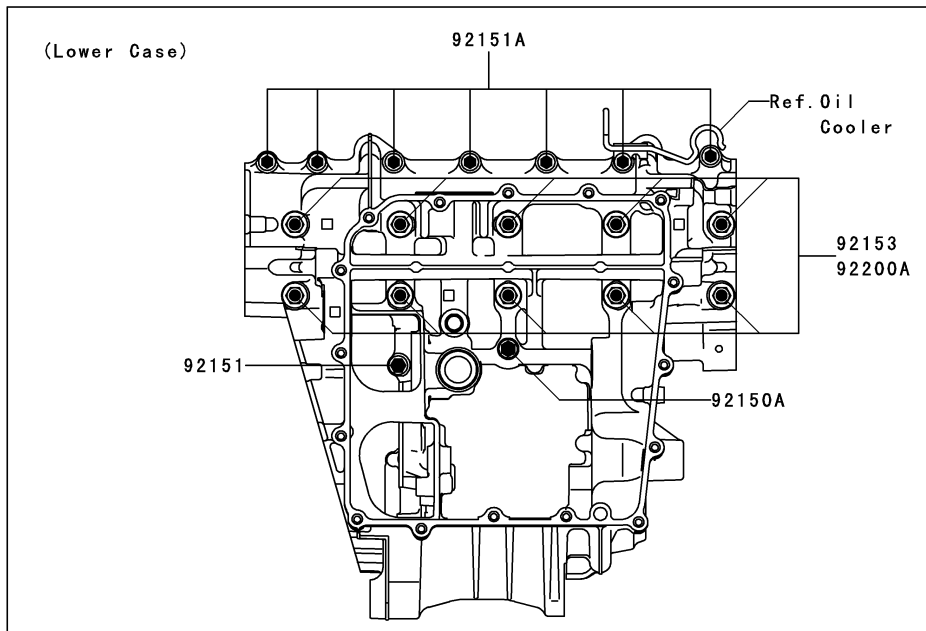
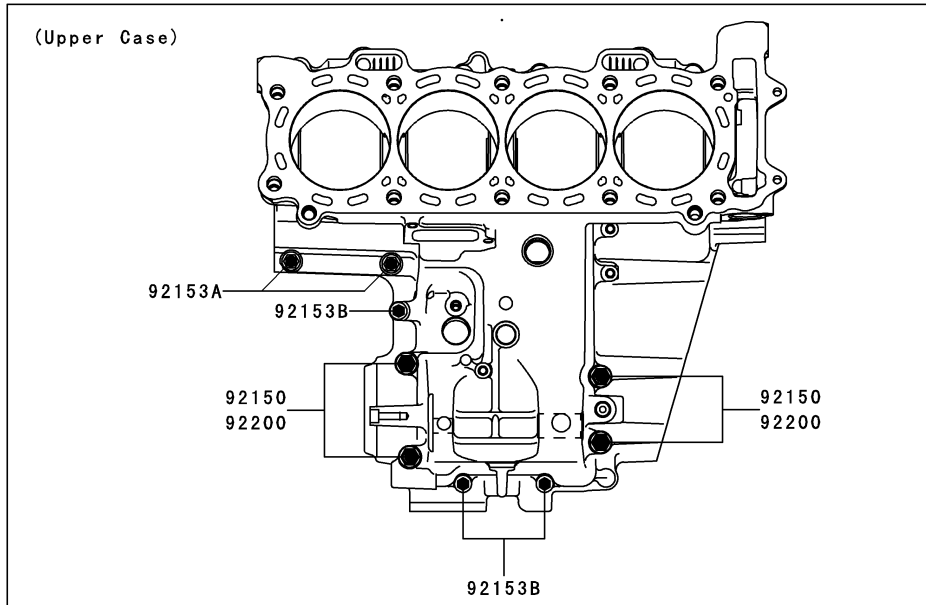

Ref. No.	Part No.	Description	Spec Code	Quantity-ZX1000	
				'08	E8F
92150	92150-1162	BOLT,8X80		4	
92150A	92150-1251	BOLT,FLANGED,7X85		1	
92151	92151-1223	BOLT,FLANGED,7X50		1	
92151A	92151-1521	BOLT,FLANGED,6X45		7	
92153	92153-0447	BOLT,FLANGED,9X100		10	
92153A	92153-0448	BOLT,FLANGED,7X32		2	
92153B	92153-1570	BOLT-FLANGED,6X40		3	
92200	92200-0047	WASHER,8.2X16X1.6		4	
92200A	92200-0115	WASHER,9.2X19X23		10	

This catalog covers:
'08 ZX1000E8F Engine

GRID NO.

C-7

This grid covers:
Engine Cover(s)

E1431

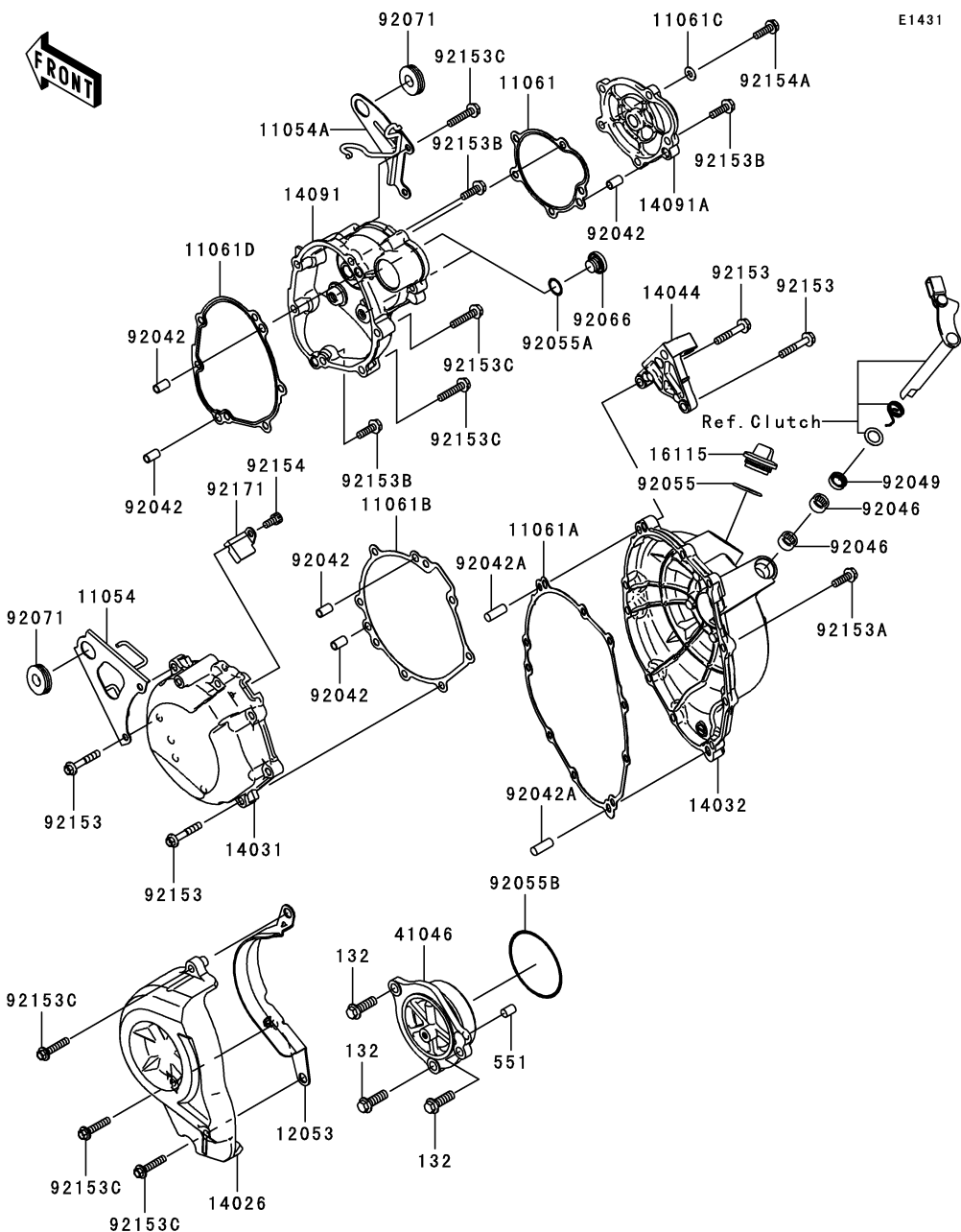

Ref. No.	Part No.	Description	Spec Code	Quantity-ZX1000		
				'08		
11054	11054-1958	BRACKET,GENERATOR COVER				1
11054A	11054-1959	BRACKET,STARTER COVER				1
11061	11061-0177	GASKET,IDLE GEAR COVER				1
11061A	11061-0178	GASKET,CLUTCH COVER				1
11061B	11061-0179	GASKET,GENERATOR COVER				1
11061C	11061-0262	GASKET,6.2X13.5X1.0				1
11061D	11061-0336	GASKET,LARGE COVER				1
12053	12053-0089	GUIDE-CHAIN				1
14026	14026-0054	COVER-CHAIN				1
14031	14031-0045-11E	COVER-GENERATOR,F.S.BLACK				1
14032	14032-0105	COVER-CLUTCH				1
14044	14044-0031	HOLDER-CABLE				1
14091	14091-0860	COVER,STARTER,LARGE				1
14091A	14091-0905	COVER,STARTER,SMALL				1
16115	16115-1009	CAP-OIL FILLER				1
41046	41046-0012	HOUSING-BEARING				1
92042	92042-007	PIN,DOWEL,6.3X8X14				5
92042A	92042-044	PIN,DOWEL,8X22				2
92046	92046-1010	BEARING-NEEDLE,HK1210				2
92049	92049-1475	SEAL-OIL,CLUTCH RELEASE				1
92055	92055-049	RING-O,31.7X2.4				1
92055A	92055-1141	RING-O,ID=13.8				2
92055B	92055-1408	RING-O,65.2X2.4				1
92066	92066-0067	PLUG,TIMING HOLE				2
92071	92071-1043	GROMMET				2
92153	92153-0690	BOLT,FLANGED,6X35				10
92153A	92153-0764	BOLT,FLANGED,6X25				8
92153B	92153-1010	BOLT-FLANGED,6X20				6
92153C	92153-1315	BOLT-FLANGED,6X30				7
92154	92154-0040	BOLT,SOCKET,6X12				1
92154A	92154-0093	BOLT,FLANGED,6X20				1
92171	92171-1566	CLAMP				1
132	132BD0825	BOLT-FLANGED-SMALL,8X25				3
551	551A0812	PIN-DOWEL,8X12				1

This catalog covers:
'08 ZX1000E8F Engine

GRID NO. This grid covers:

C-8

Oil Pan

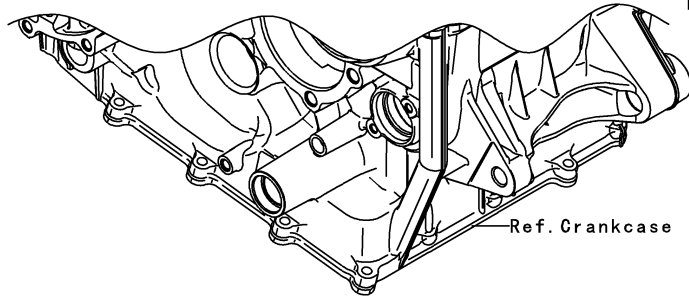

E1434

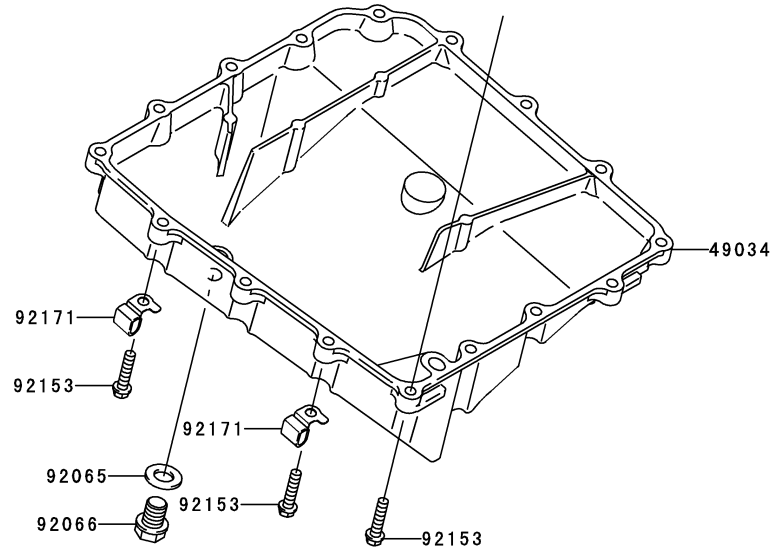
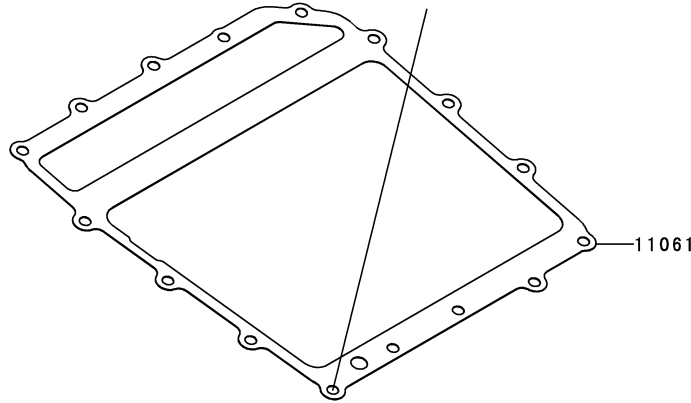

Ref. No.	Part No.	Description	Spec Code	Quantity-ZX1000	
				'08	E8F
11061	11061-0180	GASKET,OIL PAN		1	
49034	49034-0020	PAN-OIL		1	
92065	92065-097	GASKET,12X22X2		1	
92066	92066-1174	PLUG,OIL DRAIN,12X15		1	
92153	92153-1569	BOLT-FLANGED,6X25		16	
92171	92171-0703	CLAMP		2	

This catalog covers:
'08 ZX1000E8F Engine

GRID NO. **C-9** This grid covers:
Throttle

E1510

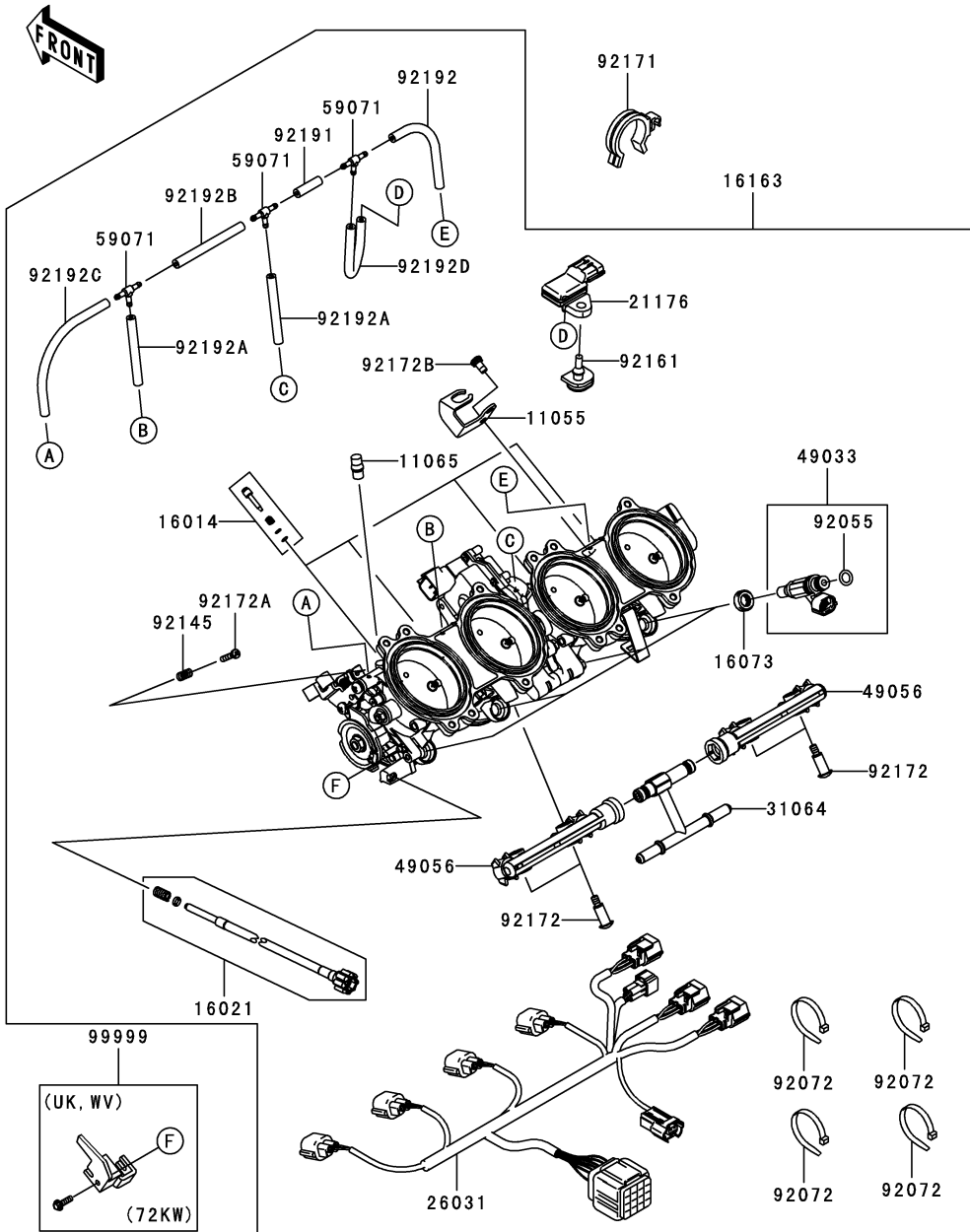

Ref. No.	Part No.	Description	Spec Code	Quantity-ZX1000		
				'08		
11055	11055-1257	BRACKET				1
11065	11065-0282	CAP				4
16014	16014-0002	SCREW-PILOT AIR				4
16021	16021-0020	SCREW-THROTTLE STOP				1
16073	16073-3707	INSULATOR				4
16163	16163-0115	THROTTLE-ASSY,TTK43				1
21176	21176-0058	SENSOR,PRESSURE				1
26031	26031-0580	HARNESS,THROTTLE SUB				1
31064	31064-0023	PIPE-COMP,FUEL				1
49033	49033-0011	NOZZLE-INJECTION				4
49056	49056-0024	PIPE-INJECTION				2
59071	59071-3752	JOINT,3WAY,T				3
92055	92055-1622	RING-O,INJECTION NOZZLE				4
92072	92072-0012	BAND,SUB-HARNESS				AR
92145	92145-0055	SPRING,THROTTLE SYNCRO				1
92161	92161-0041	DAMPER				1
92171	92171-0359	CLAMP				1
92172	92172-0064	SCREW,PIPE INJECTION				4
92172A	92172-0065	SCREW,THROTTLE SYNCRO				1
92172B	92172-0393	SCREW				1
92191	92191-0020	TUBE,3X7X25				1
92192	92192-0018	TUBE,3X7X95				1
92192A	92192-0106	TUBE				2
92192B	92192-0739	TUBE				1
92192C	92192-0740	TUBE				1
92192D	92192-0741	TUBE				1
99999	99999-0148	KIT.,72KW				1
		L----- UK,WV				

E1515



Ref. No.	Part No.	Description	Spec Code	Quantity-ZX1000			
				'08			
				E8F			

16073	16073-0076	INSULATOR		4
49033	49033-0017	NOZZLE-INJECTION		4
49056	49056-0025	PIPE-INJECTION		2
51044	51044-0046	TUBE-ASSY,FUEL		1
59071	59071-0062	JOINT		1
59478	59478-0006	NOZZLE-ASSY		1
92055	92055-0064	RING-O		2
92055A	92055-0170	RING-O		4
92172	92172-0064	SCREW,PIPE INJECTION		4
130	130BB0514	BOLT-FLANGED,5X14		5

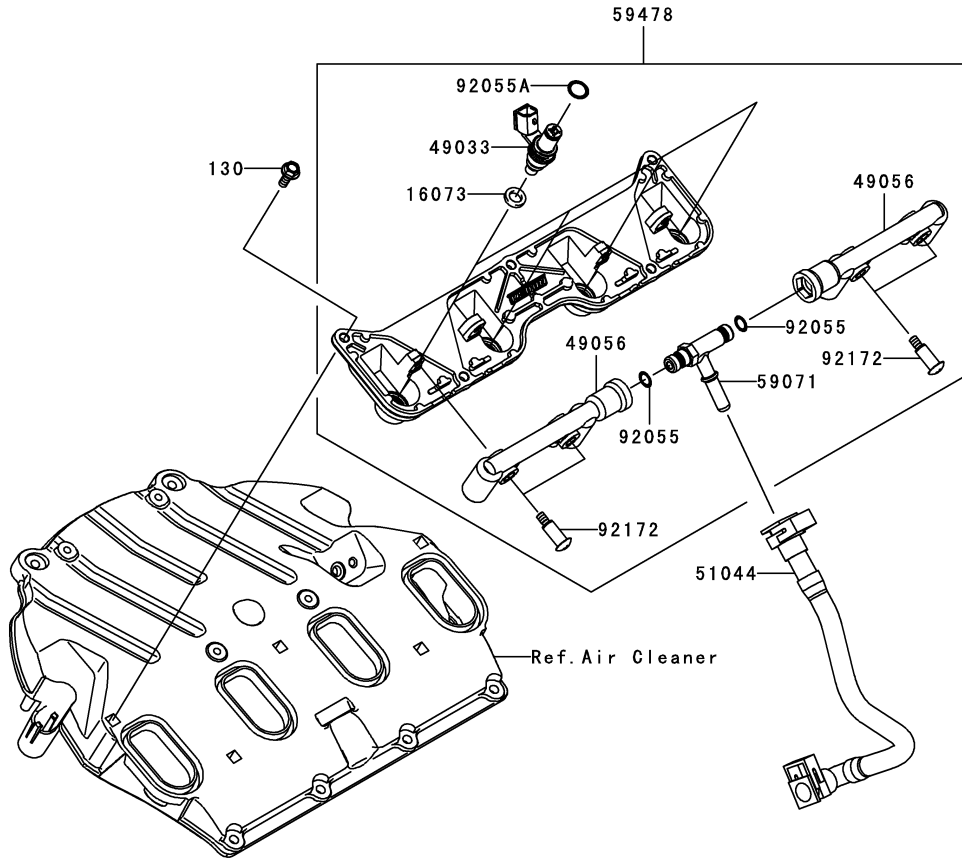

This catalog covers:
'08 ZX1000E8F Engine

GRID NO. **C-11** This grid covers:
Fuel Pump

E1520

Ref. No.	Part No.	Description	Spec Code	Quantity-ZX1000	
				'08	E8F
49040	49040-0030	PUMP-FUEL		1	
51044	51044-0047	TUBE-ASSY,FUEL		1	
92153	92153-1283	BOLT,FLANGED,6X12		5	
670	670E5075	O RING		1	

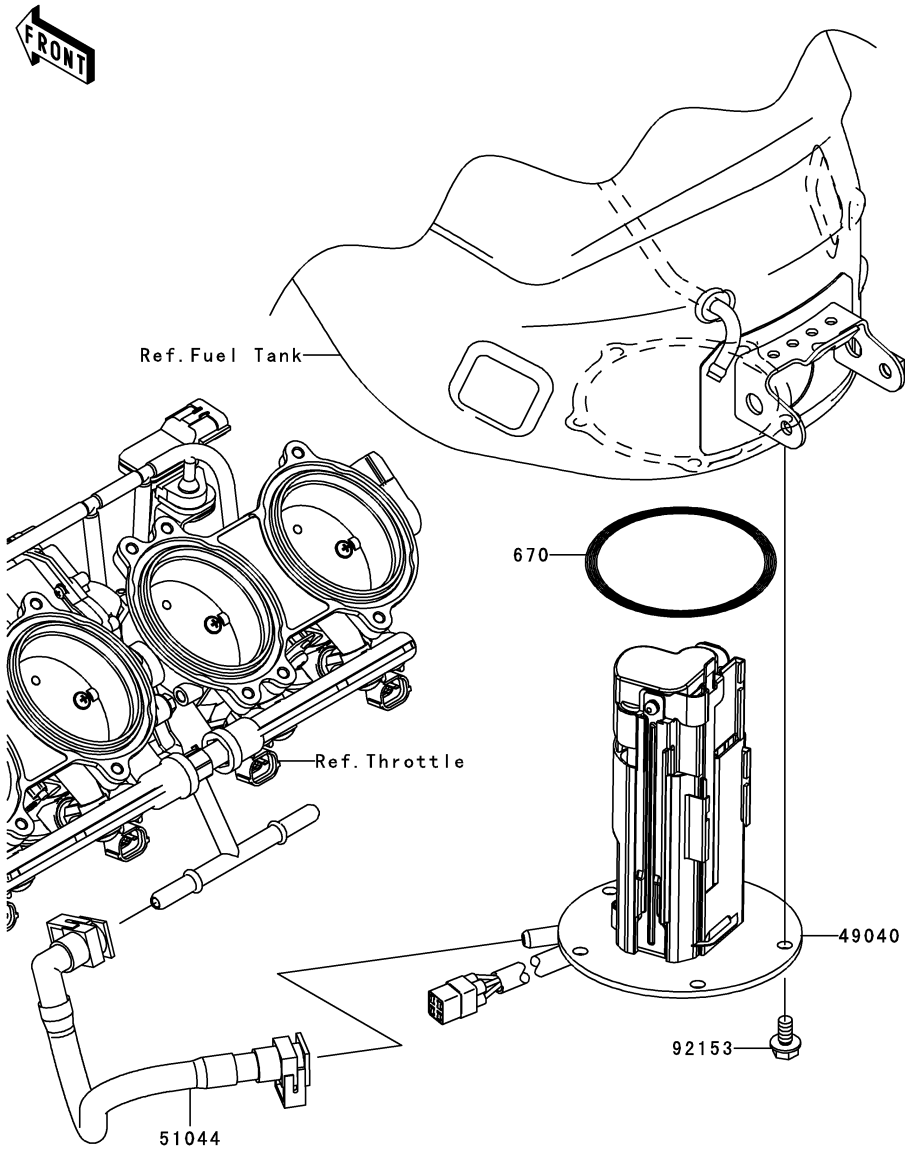

E1530

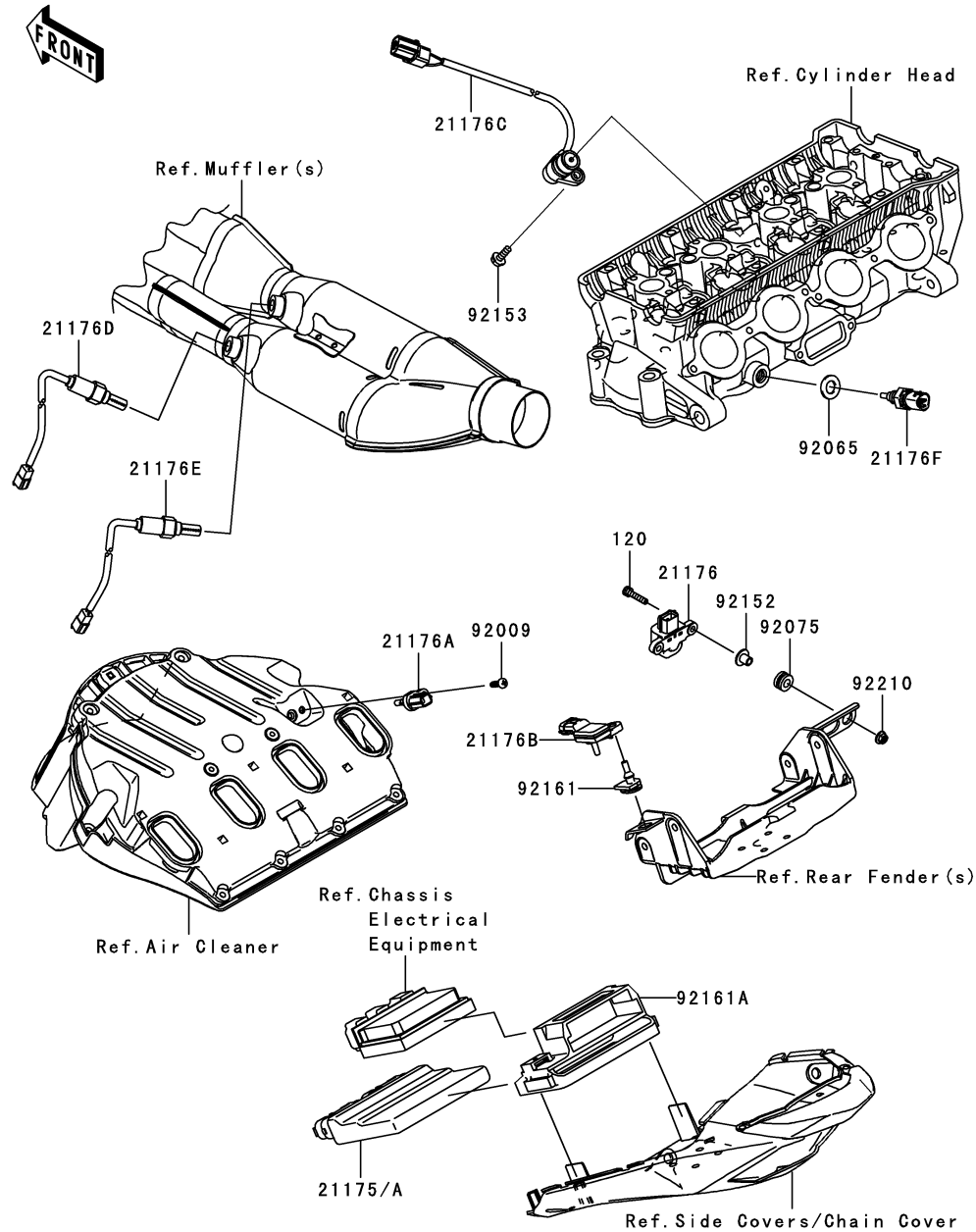

Ref. No.	Part No.	Description	Spec Code	Quantity-ZX1000	
				'08	E8F
21175	21175-0158	CONTROL UNIT-ELECTRONIC			
		L-----UK,WV			1
21175A	21175-0190	CONTROL UNIT-ELECTRONIC			
		L-----FR			1
21176	21176-0026	SENSOR,VEHICLE-DOWN			1
21176A	21176-0048	SENSOR,AIR TEMPERATURE			1
21176B	21176-0058	SENSOR,PRESSURE			1
21176C	21176-0101	SENSOR,CAM			1
21176D	21176-0114	SENSOR,OXYGEN			1
21176E	21176-0115	SENSOR,OXYGEN			1
21176F	21176-1120	SENSOR,WATER TEMP			1
92009	92009-1984	SCREW,TAPPING,5X16			1
92065	92065-097	GASKET,12X22X2			1
92075	92075-1912	DAMPER			2
92152	92152-0134	COLLAR			2
92153	92153-1584	BOLT-FLANGED,6X16			1
92161	92161-0041	DAMPER			1
92161A	92161-0529	DAMPER,ECU			1
92210	92210-0007	NUT,FLANGED,5MM			2
120	120CB0522	BOLT-SOCKET,5X22			2

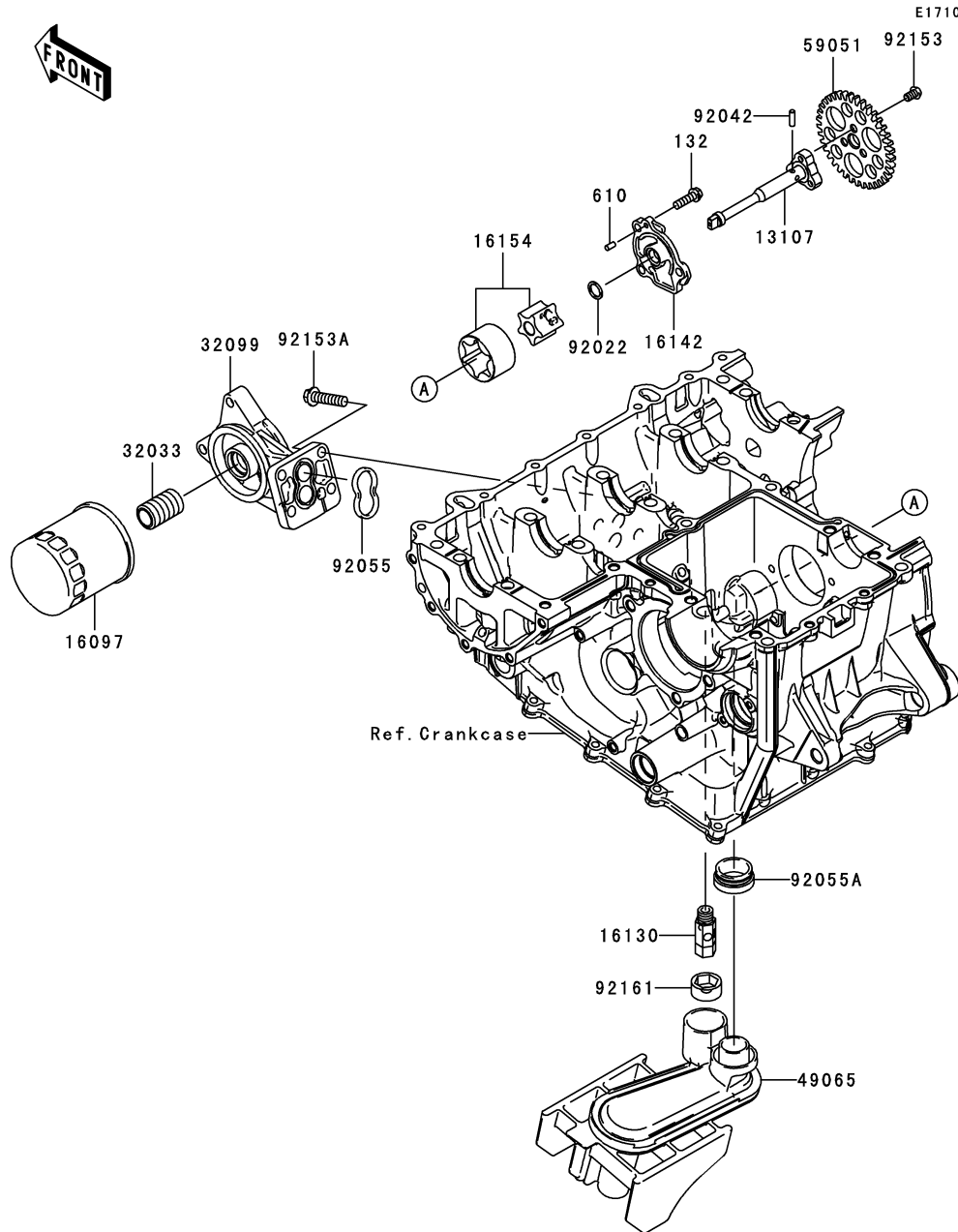

Ref. No.	Part No.	Description	Spec Code	Quantity-ZX1000	
				'08	E8F
13107	13107-0060	SHAFT		1	
16097	16097-0004	FILTER-ASSY-OIL		1	
16130	16130-1059	VALVE-ASSY-RELIEF		1	
16142	16142-0005	COVER-PUMP		1	
16154	16154-0057	ROTOR-PUMP		1	
32033	32033-1535	PIPE,OIL FILTER		1	
32099	32099-0023	CASE,OIL FILTER		1	
49065	49065-0013	FILTER-OIL		1	
59051	59051-0080	GEAR-SPUR,OIL PUMP,40T		1	
92022	92022-311	WASHER,11.2X15X1		1	
92042	92042-030	PIN,DOWEL,4X13.8		1	
92055	92055-0018	RING-O,OIL LINE		1	
92055A	92055-1503	RING-O,OIL FILTER		1	
92153	92153-0661	BOLT,TORX,M6X10		3	
92153A	92153-1086	BOLT,FLANGED,8X30		4	
92161	92161-0070	DAMPER		1	
132	132BC620	BOLT-FLANGED-SMALL,6X20		3	
610	610A0408	ROLLER,4X8		1	

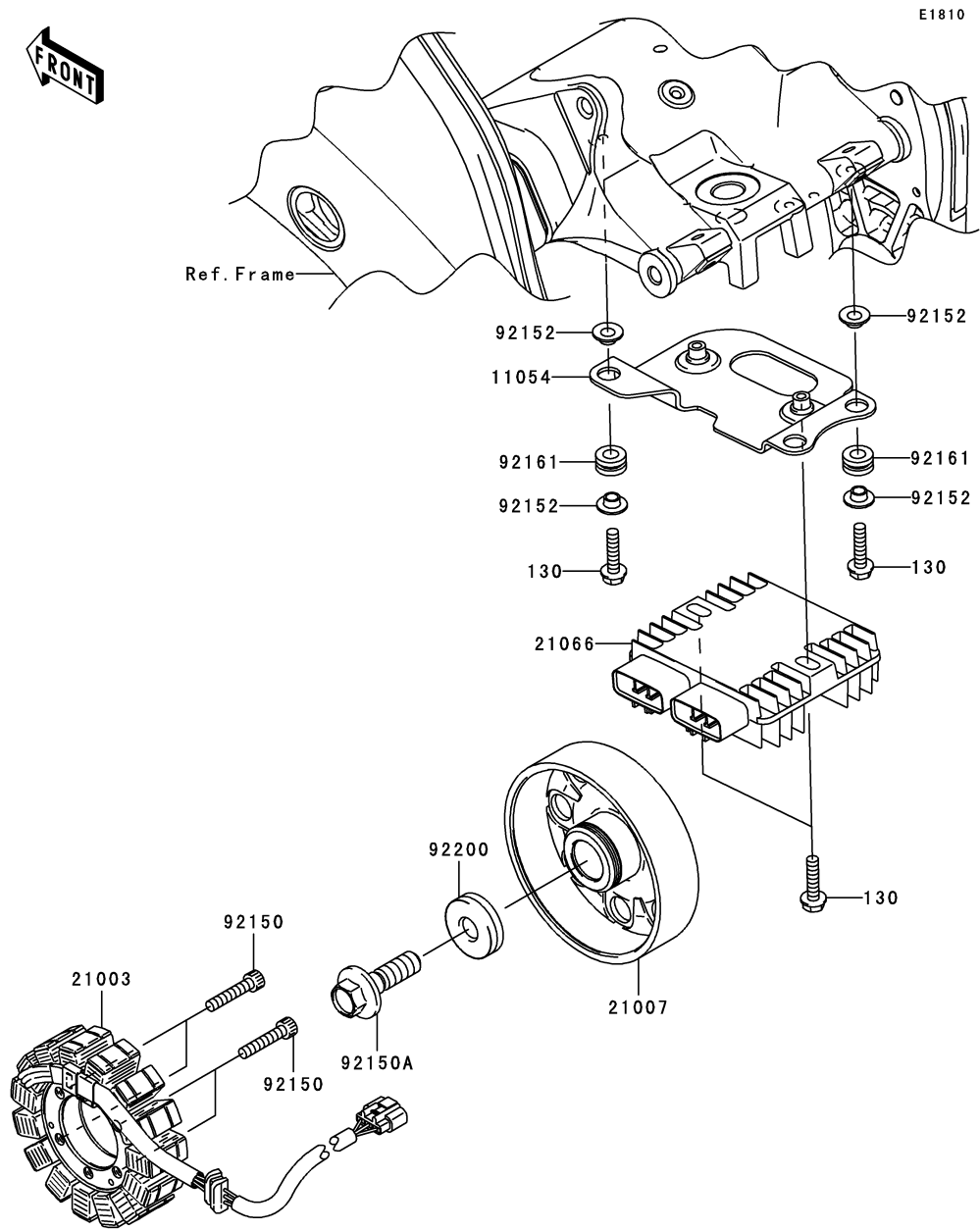

Ref. No.	Part No.	Description	Spec Code	Quantity-ZX1000	
				'08	E8F

11054	11054-1960	BRACKET,REGULATOR		1
21003	21003-0072	STATOR		1
21007	21007-0117	ROTOR		1
21066	21066-0028	REGULATOR-VOLTAGE		1
92150	92150-1433	BOLT,SOCKET,6X30		4
92150A	92150-1717	BOLT,12X40		1
92152	92152-0718	COLLAR		6
92161	92161-0056	DAMPER		3
92200	92200-0369	WASHER,12X34X9		1
130	130BB0622	BOLT-FLANGED,6X22		5

This catalog covers:
'08 ZX1000E8F Engine

GRID NO. **D-3** This grid covers:
Ignition System

E1830

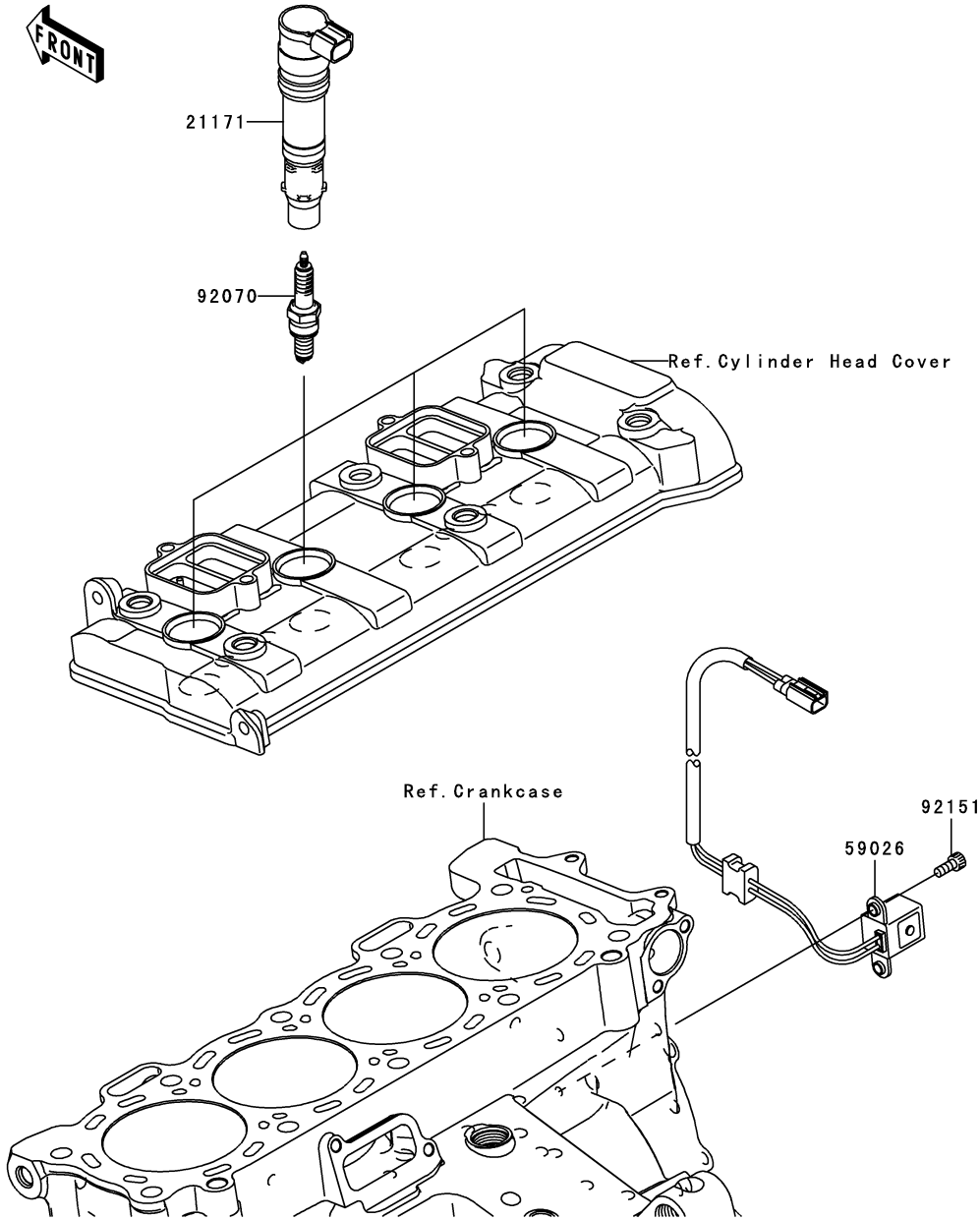

Ref. No.	Part No.	Description	Spec Code	Quantity-ZX1000			
				'08			
21171	21171-0005	COIL-ASSY-IGNITION		4			
59026	59026-0031	COIL-PULSING		1			
92070	92070-0014	PLUG-SPARK,CR9EIA(NGK)		4			
92151	92151-1118	BOLT,SOCKET,5X12		2			

This catalog covers:
'08 ZX1000E8F Engine

GRID NO. **D-5** This grid covers:
Radiator

E3032

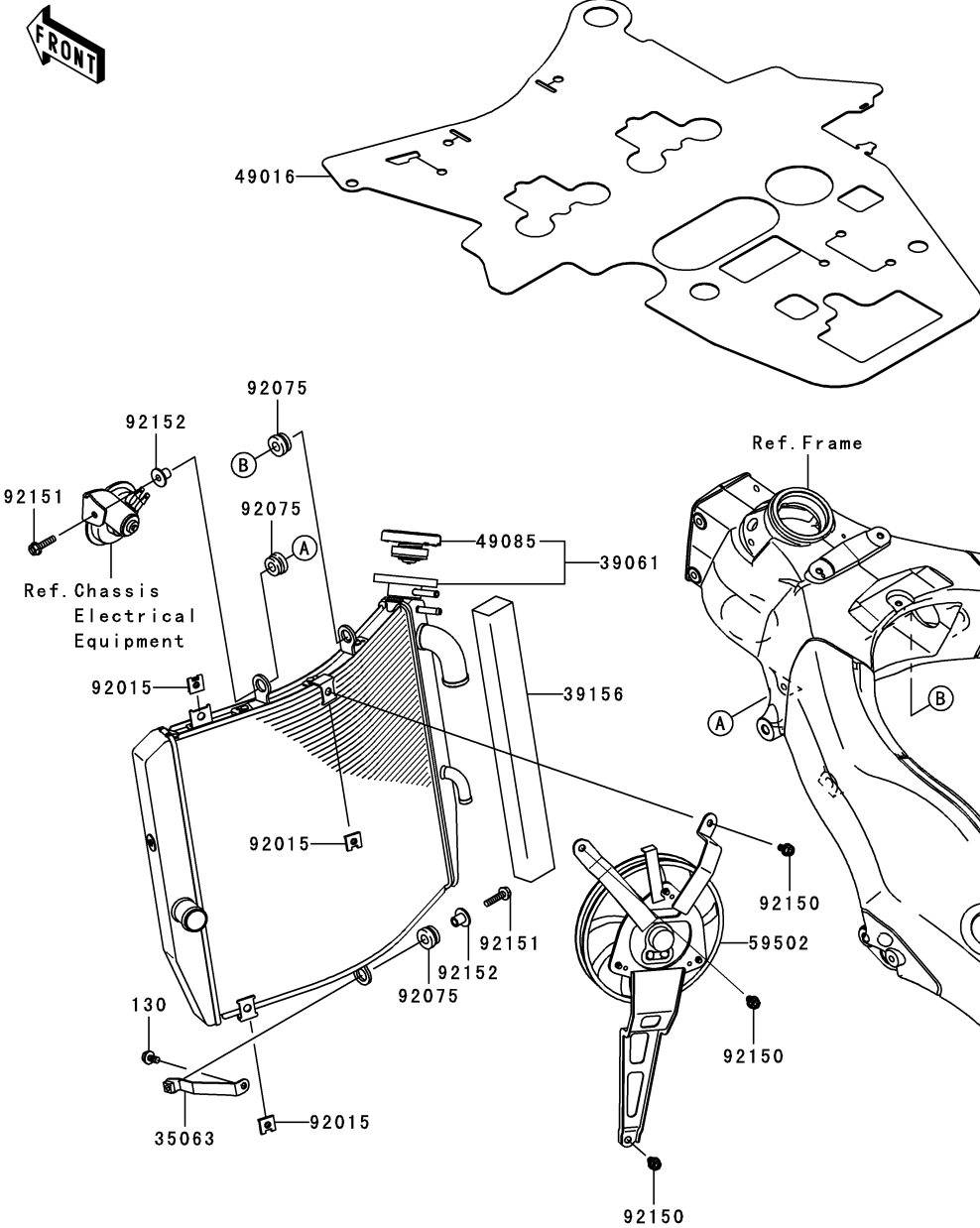

Ref. No.	Part No.	Description	Spec Code	Quantity-ZX1000	
				'08	E8F
35063	35063-0448	STAY		1	
39061	39061-0121	RADIATOR-ASSY		1	
39156	39156-0454	PAD		1	
49016	49016-0054	COVER-SEAL,HEAT		1	
49085	49085-1066	CAP-ASSY-PRESSURE		1	
59502	59502-0033	FAN-ASSY		1	
92015	92015-1487	NUT		3	
92075	92075-1123	DAMPER,RUBBER		3	
92150	92150-1186	BOLT,6X12		3	
92151	92151-1225	BOLT,FLANGED,6X25		2	
92152	92152-1074	COLLAR		2	
130	130BB0614	BOLT-FLANGED,6X14		1	

This catalog covers:
'08 ZX1000E8F Engine

GRID NO. This grid covers:
D-6 Oil Cooler

E3034

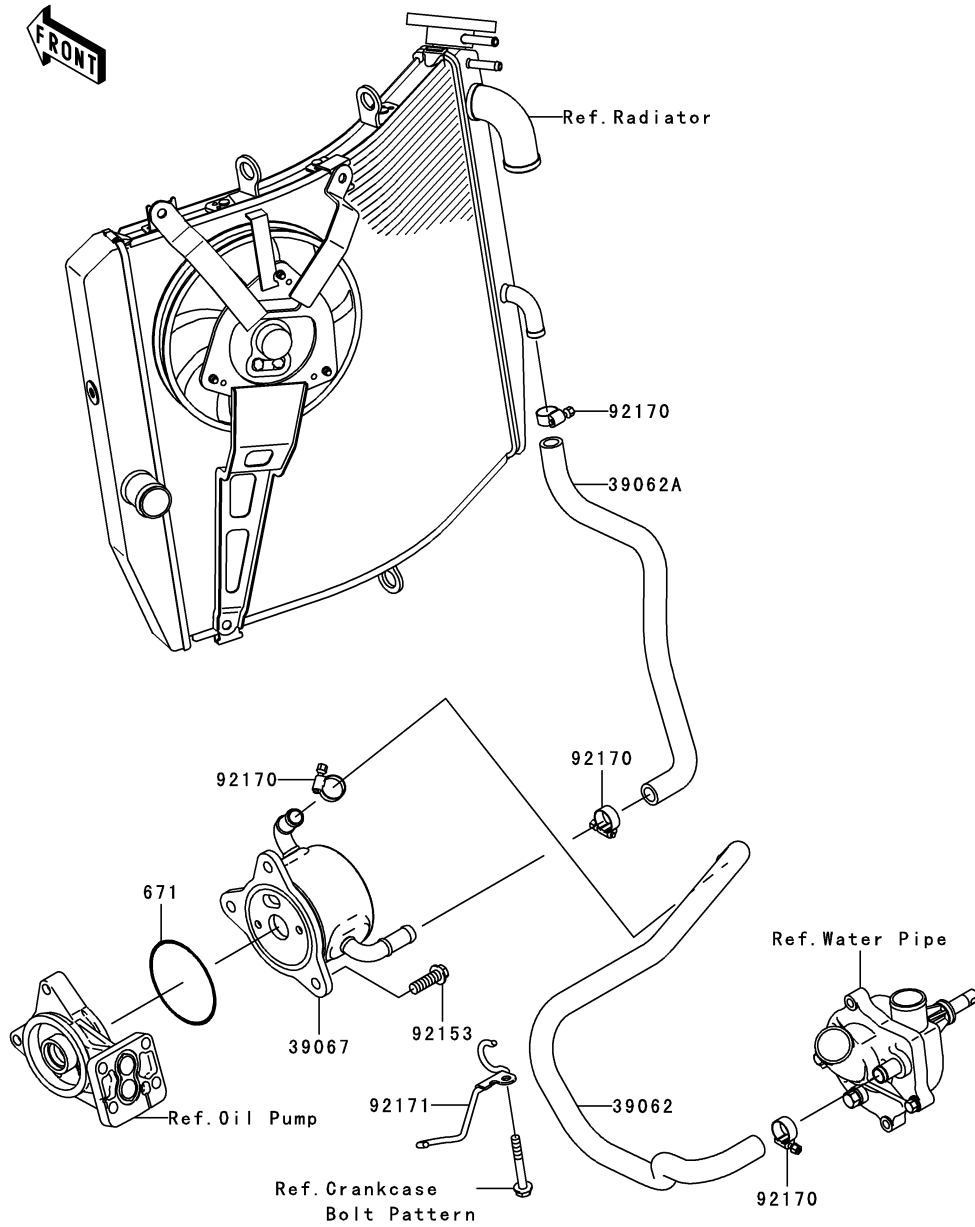

Ref. No.	Part No.	Description	Spec Code	Quantity-ZX1000		
				'08		
39062	39062-0230	HOSE-COOLING,OIL COOLER-W.PUMP				1
39062A	39062-0236	HOSE-COOLING,RAD.-OIL COOLER				1
39067	39067-0009	COOLER-OIL				1
92153	92153-0564	BOLT,8X25				3
92170	92170-3729	CLAMP				4
92171	92171-0723	CLAMP				1
671	671B2565	O RING,65MM				1

This catalog covers:

'08 ZX1000E8F Chassis

GRID NO.

E-3

This grid covers:

Frame

F2120

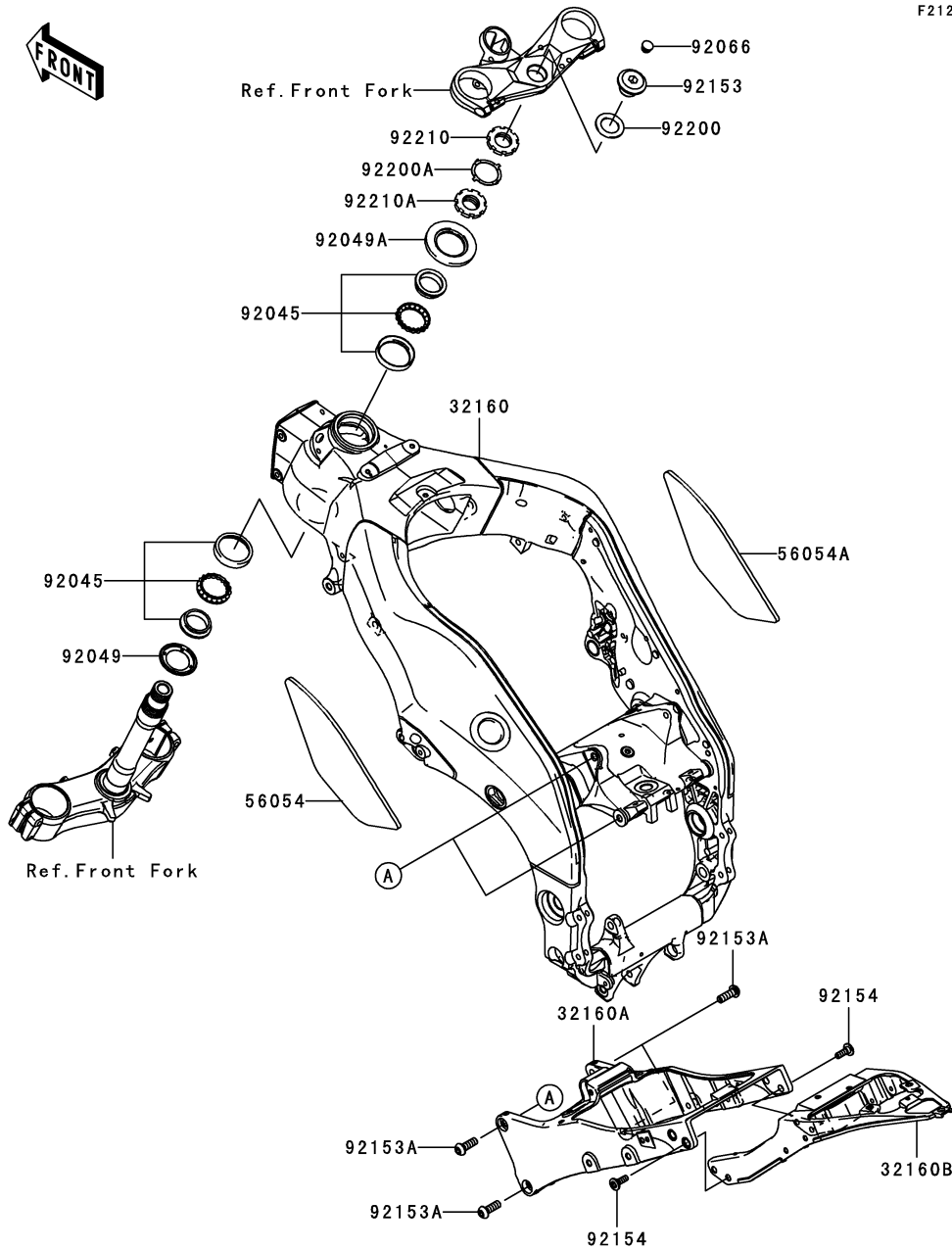

Ref. No.	Part No.	Description	Spec Code	Quantity-ZX1000	
				'08	E8F
32160	32160-0254-18R	FRAME-COMP,FR,F.S.BLACK		1	
32160A	32160-0255-18R	FRAME-COMP,RR,FR,F.S.BLACK		1	
32160B	32160-0347	FRAME-COMP,RR,RR		1	
56054	56054-0238	MARK,FRAME,LH		1	
56054A	56054-0239	MARK,FRAME,RH		1	
92045	92045-1384	BEARING-BALL,SF07A17PX1V1		2	
92049	92049-0022	SEAL-OIL,DS35X55X4		1	
92049A	92049-1382	SEAL-OIL,XMH 43 75 6.4J		1	
92066	92066-0071	PLUG		1	
92153	92153-0474	BOLT,26MM		1	
92153A	92153-1933	BOLT,SOCKET,10X30		4	
92154	92154-0077	BOLT,SOCKET,8X23		4	
92200	92200-0081	WASHER,27X42X2.3		1	
92200A	92200-0281	WASHER		1	
92210	92210-0095	NUT,35MM		1	
92210A	92210-0096	NUT,35MM		1	

This catalog covers:

'08 ZX1000E8F Chassis

GRID NO.

E-5

This grid covers:

Frame Fittings

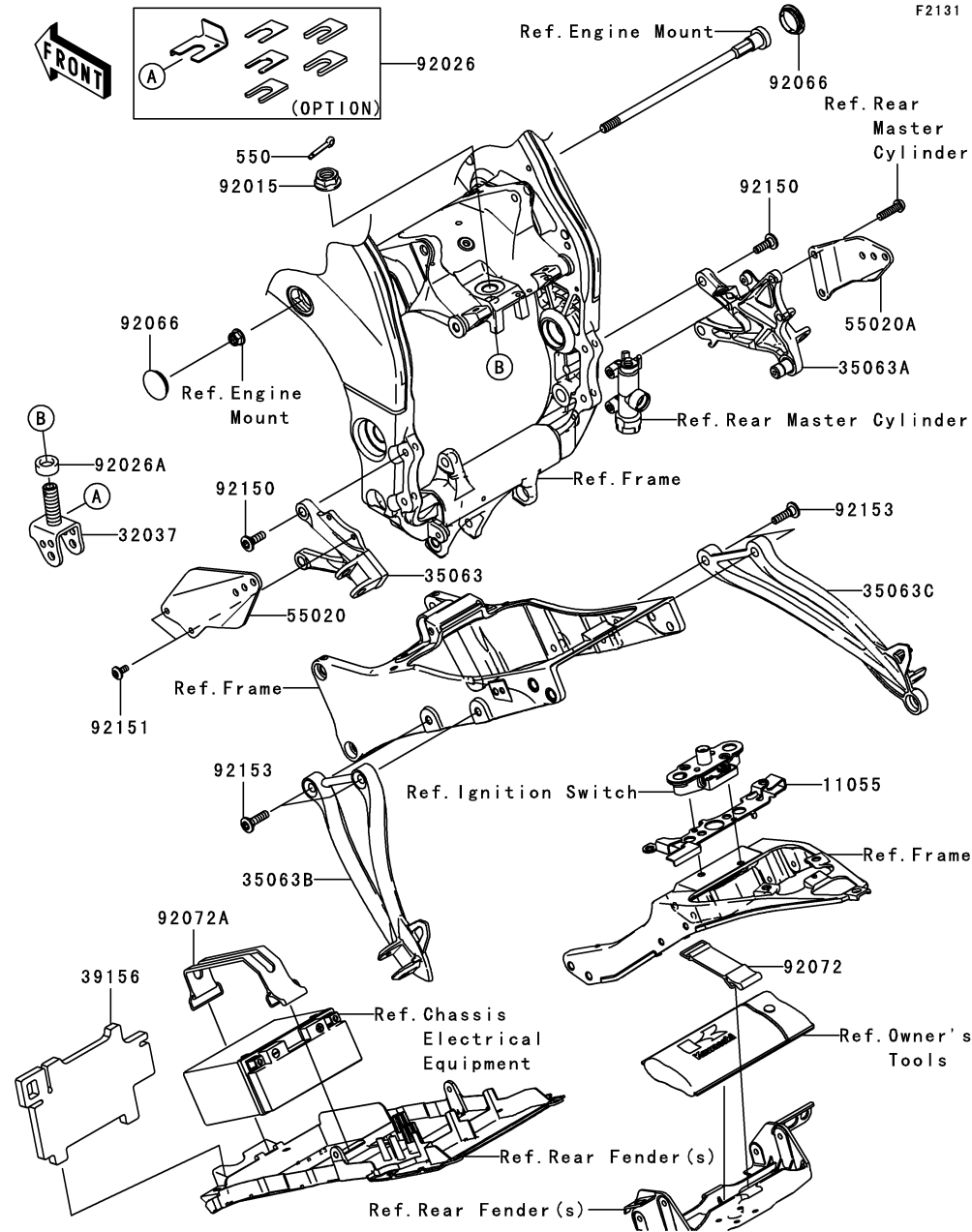

Ref. No.	Part No.	Description	Spec Code	Quantity-ZX1000	
				'08	E8F
11055	11055-1011	BRACKET,HELMET HOLDER			1
32037	32037-0013	BRACKET-SHOCKABSORBER			1
35063	35063-0226-11E	STAY,FR,LH,F.S.BLACK			1
35063A	35063-0227-11E	STAY,FR,RH,F.S.BLACK			1
35063B	35063-0444-11E	STAY,RR,LH,F.S.BLACK			1
35063C	35063-0445-11E	STAY,RR,RH,F.S.BLACK			1
39156	39156-0443	PAD,BATTERY			1
55020	55020-0414	GUARD,FRONT STEP STAY,LH			1
55020A	55020-0415	GUARD,FRONT STEP STAY,RH			1
92015	92015-1881	NUT,FLANGED,16MM			1
92026	92026-0057 (OPTION)	SPACER,SET			1
92026A	92026-0129	SPACER,16.5X26X10			1
92066	92066-0120	PLUG			2
92072	92072-1176	BAND,TOOL			1
92072A	92072-1306	BAND,L=168			1
92150	92150-1845	BOLT,8X25			4
92151	92151-1654	BOLT,SOCKET,6X14			2
92153	92153-1630	BOLT,SOCKET,8X30			4
550	550S3025	PIN-COTTER,3X25			1

This catalog covers:

'08 ZX1000E8F Chassis

GRID NO.

E-8

This grid covers:

Footrests

F2160

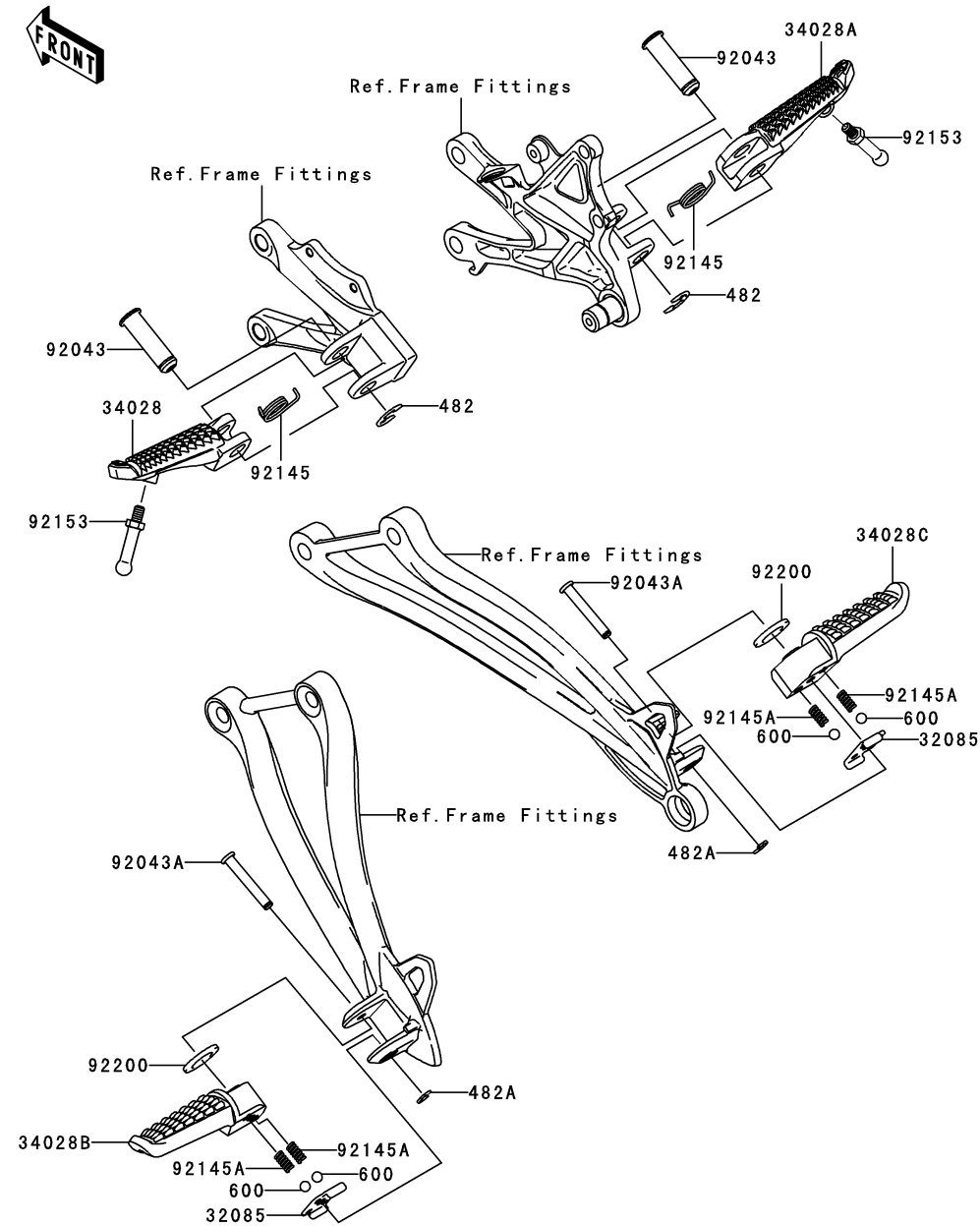

Ref. No.	Part No.	Description	Spec Code	Quantity-ZX1000			
				'08			
32085	32085-0047	STOPPER,REAR STEP				2	
34028	34028-0092	STEP,FR,LH				1	
34028A	34028-0093	STEP,FR,RH				1	
34028B	34028-0094	STEP,RR,LH				1	
34028C	34028-0095	STEP,RR,RH				1	
92043	92043-0028	PIN,12X36.5				2	
92043A	92043-1595	PIN,6X40				2	
92145	92145-0603	SPRING,STEP RETURN				2	
92145A	92145-1319	SPRING				4	
92153	92153-1938	BOLT,BANK SENSOR				2	
92200	92200-0043	WASHER,16X26X2.3				2	
482	482L0100	CIRCLIP-TYPE-E,10MM				2	
482A	482L5000	CIRCLIP-TYPE-E,5MM				2	
600	600A0800	BALL-STEEL,1/4"				4	

F2171

Ref. No.	Part No.	Description	Spec Code	Quantity-ZX1000			
				'08			
35004	35004-0093-17H	FENDER-FRONT,P.W.ORANGE		1			
35004A	35004-0093-17K	FENDER-FRONT,M.D,BLACK		1			
92151	92151-1654	BOLT,SOCKET,6X14		4			
92200	92200-1388	WASHER,6.5X14X1		4			

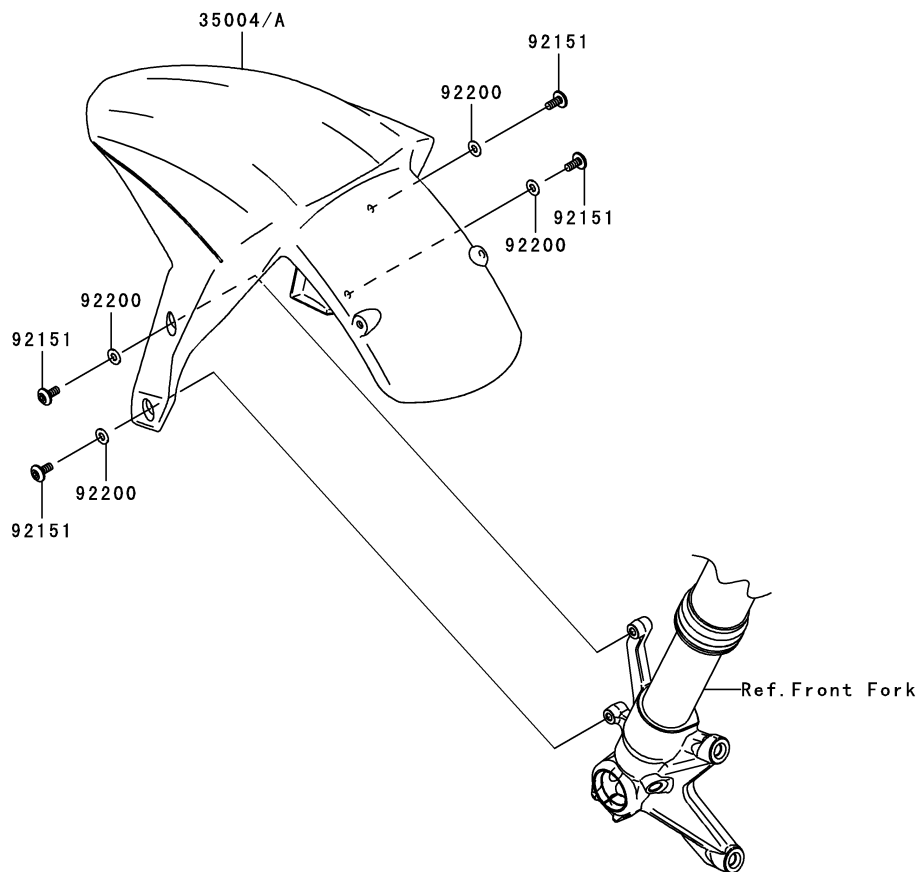

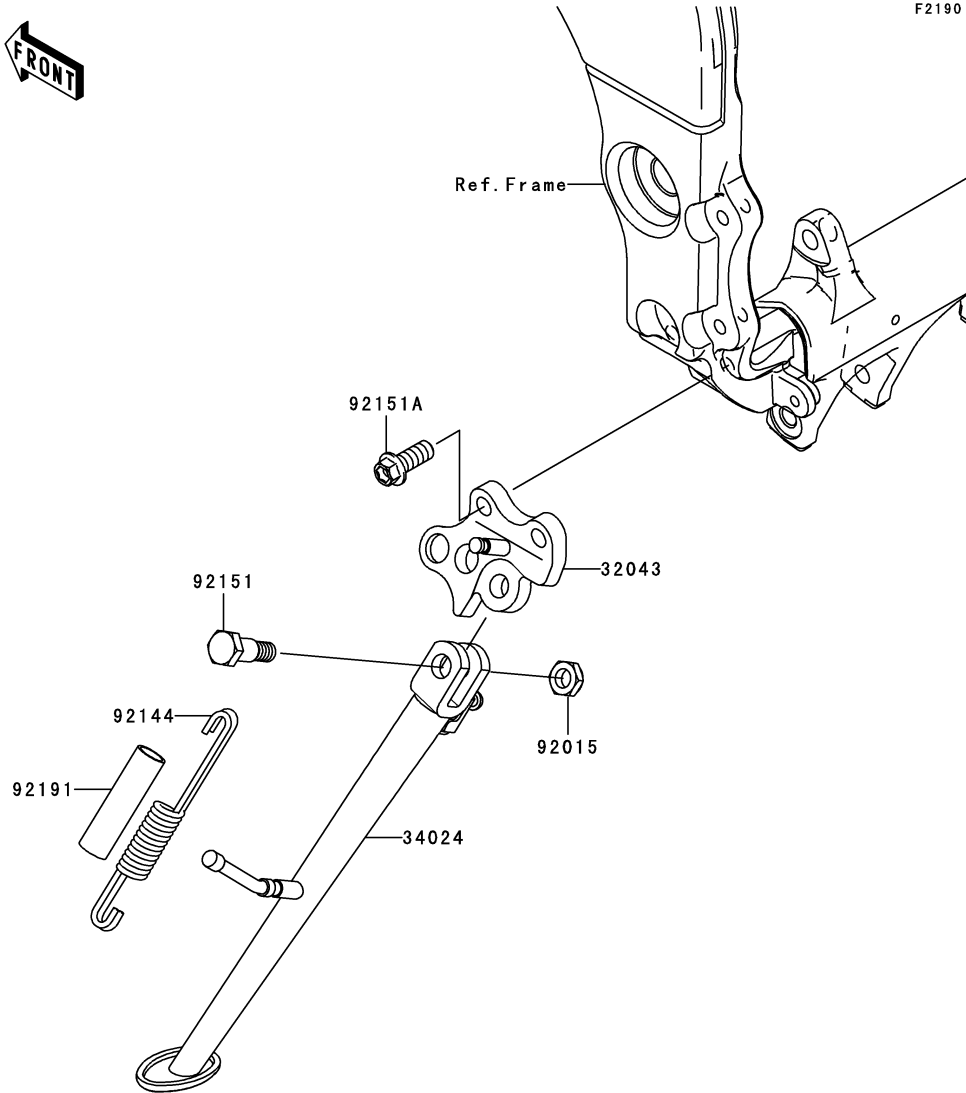

Ref. No.	Part No.	Description	Spec Code	Quantity-ZX1000		
				'08		
32043	32043-0059-18R	BRACKET-STAND,SIDE,F.S.BLACK				1
34024	34024-0047-18R	STAND-SIDE,F.S.BLACK				1
92015	92015-1188	NUT,LOCK,10MM,BLACK				1
92144	92144-1818	SPRING,SIDE STAND				1
92151	92151-1797	BOLT,SIDE STAND				1
92151A	92151-1802	BOLT,FLANGED,10X25				2
92191	92191-1001	TUBE,13X16X60				1

F2210

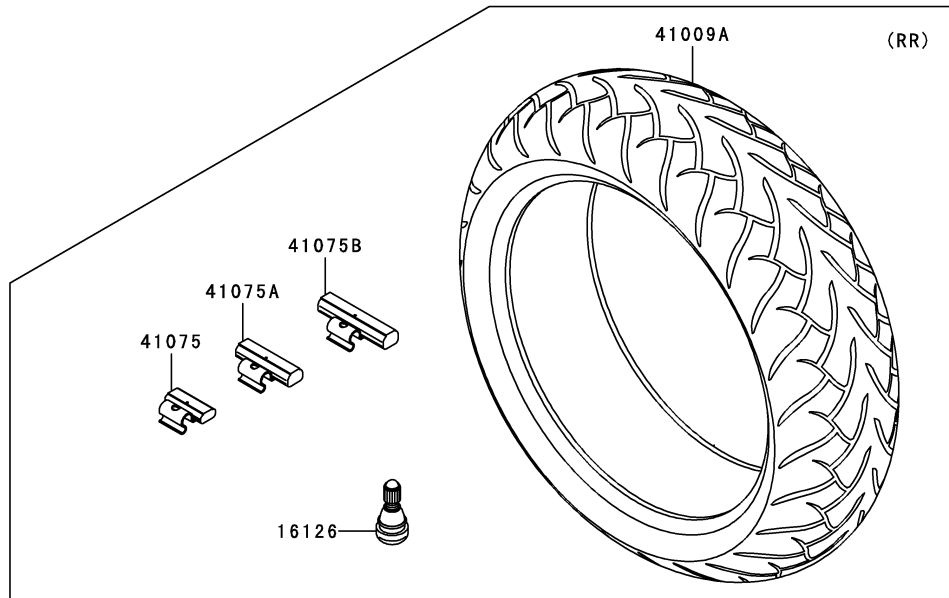
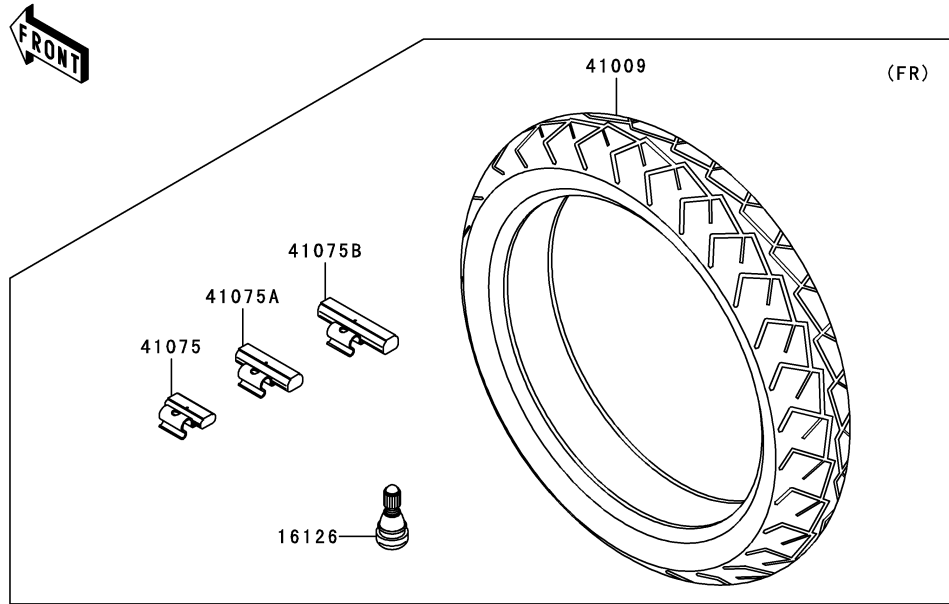

Ref. No.	Part No.	Description	Spec Code	Quantity-ZX1000			
				'08			
16126	16126-1140	VALVE,TIRE		2			
41009	41009-0186	TIRE,FR,120/70ZR17(58W)		1			
41009A	41009-0187	TIRE,RR,190/55ZR17(75W)		1			
41075	41075-0007	BALANCER-WHEEL,10G,SILVER		AR			
41075A	41075-0008	BALANCER-WHEEL,20G,SILVER		AR			
41075B	41075-0009	BALANCER-WHEEL,30G,SILVER		AR			

This catalog covers:

'08 ZX1000E8F Chassis

GRID NO.

E-13

This grid covers:

Front Hub

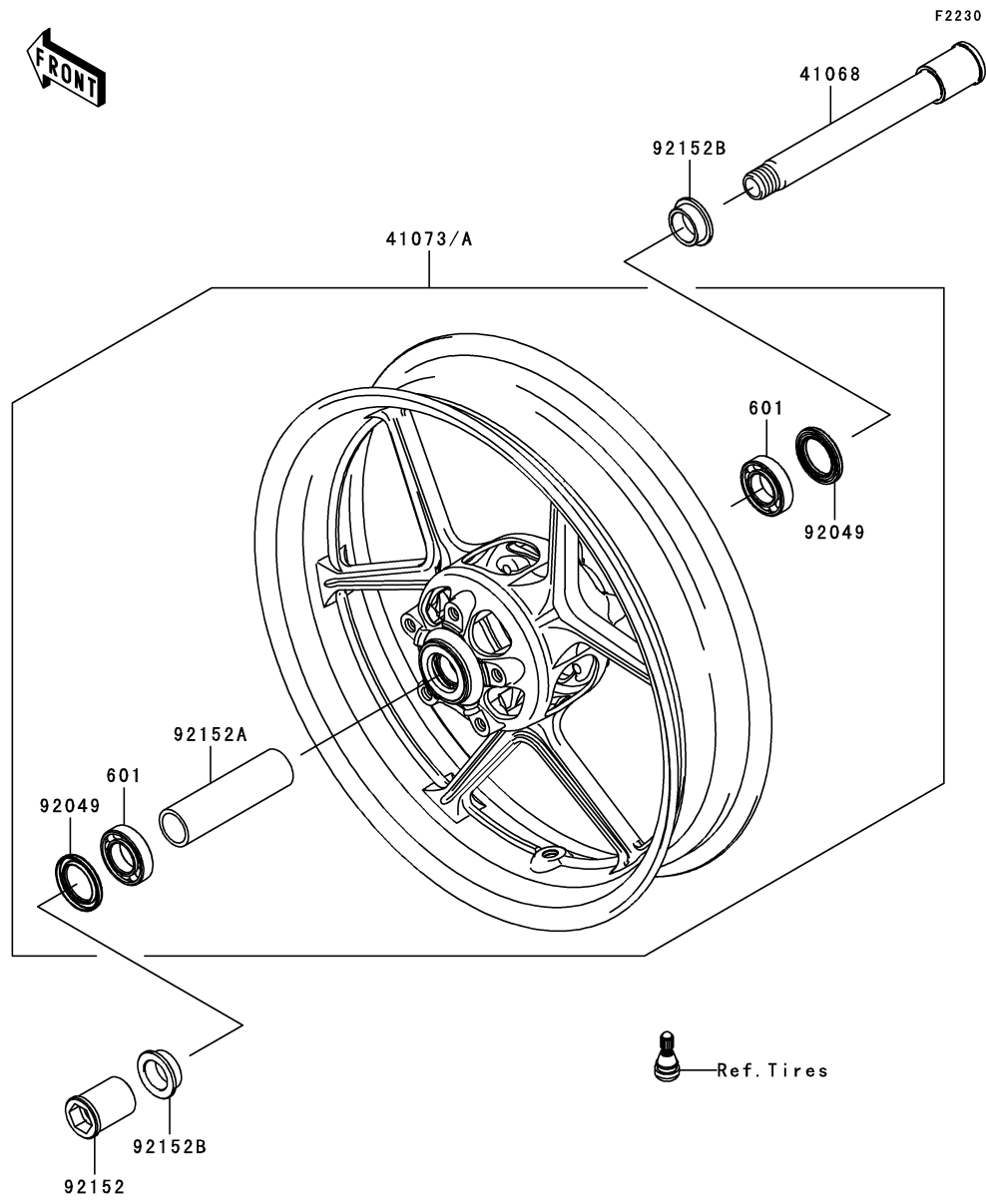

Ref. No.	Part No.	Description	Spec Code	Quantity-ZX1000		
				'08		
41068	41068-0049	AXLE,FR				1
41073	41073-0084-18F	WHEEL-ASSY,FR,BLACK				1
41073A	41073-0084-19K	WHEEL-ASSY,FR,BLACK/GREEN				1
92049	92049-0050	SEAL-OIL,BJN-C2 32X47X5				2
92152	92152-0240	COLLAR,FR AXLE,LH,L=44.5				1
92152A	92152-0242	COLLAR,FR HUB,L=115				1
92152B	92152-0289	COLLAR,FR AXLE,L=13				2
601	601B6005UU	BEARING-BALL,#6005UU				2

This catalog covers:

'08 ZX1000E8F Chassis

GRID NO.

E-14

This grid covers:

Rear Hub

F2240

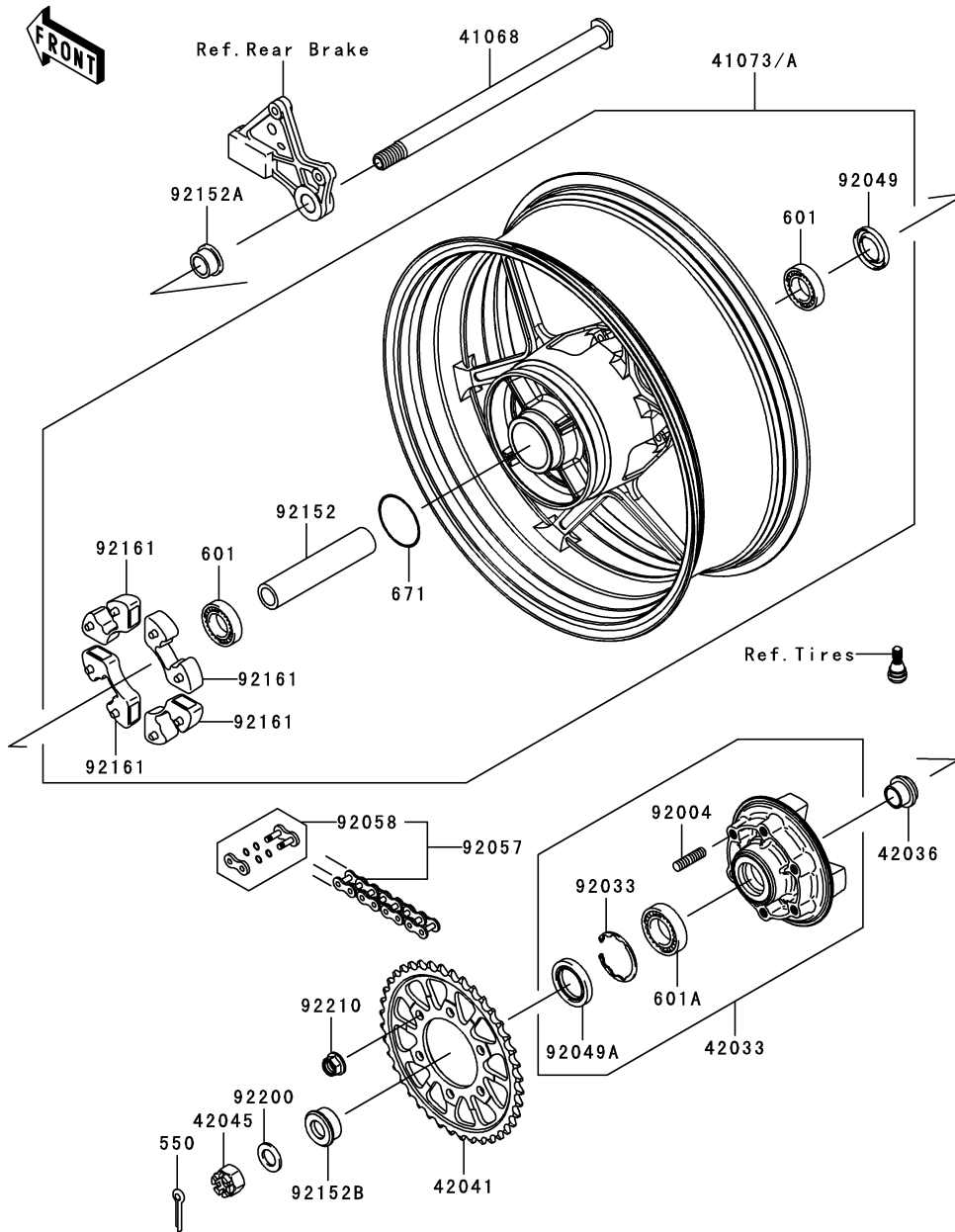

Ref. No.	Part No.	Description	Spec Code	Quantity-ZX1000	
				'08	E8F
41068	41068-0040	AXLE,RR		1	
41073	41073-0081-18F	WHEEL-ASSY,RR,G.BLACK		1	
41073A	41073-0081-19K	WHEEL-ASSY,RR,BLACK/GREEN		1	
42033	42033-0028	COUPLING-ASSY,RR HUB		1	
42036	42036-1251	SLEEVE,RR HUB,L=23		1	
42041	42041-0055	SPROCKET-HUB,41T		1	
42045	42045-018	NUT,CASTLE,18MM		1	
92004	92004-0028	STUD,10X19		6	
92033	92033-1043	RING-SNAP,52MM		1	
92049	92049-1056	SEAL-OIL,BJN28475		1	
92049A	92049-1287	SEAL-OIL		1	
92057	92057-0140	CHAIN,DRIVE,RK525MFOZX110L		1	
92058	92058-0015	JOINT-CHAIN,DRIVE		1	
92152	92152-0088	COLLAR,RR HUB,L=144.5		1	
92152A	92152-0105	COLLAR,RR AXLE,RH,L=17		1	
92152B	92152-0206	COLLAR,RR AXLE,LH,L=18		1	
92161	92161-0342	DAMPER,SHOCK,RR HUB		4	
92200	92200-1489	WASHER,19X32X2.6		1	
92210	92210-0276	NUT,LOCK,FLANGED,10MM		6	
550	550D4035	PIN-COTTER,4.0X35		1	
601	601B6204UU	BEARING-BALL,6204UUC3		2	
601A	601B6205UU	BEARING-BALL		1	
671	671B2560	O RING,60MM		1	

F2260



Ref. No.	Part No.	Description	Spec Code	Quantity-ZX1000			
				'08			

13236	13236-0146	LEVER-COMP,BRAKE PEDAL		1
92145	92145-0230	SPRING,BRAKE PEDAL RETURN		1
92190	92190-1185	TUBE,16X19X30		1
92200	92200-0279	WASHER,7X28X1.6		1
92200A	92200-0280	WASHER,15.3X24X1.0		1
180	180BA0614	BOLT-UPSET-WS,6X14		1

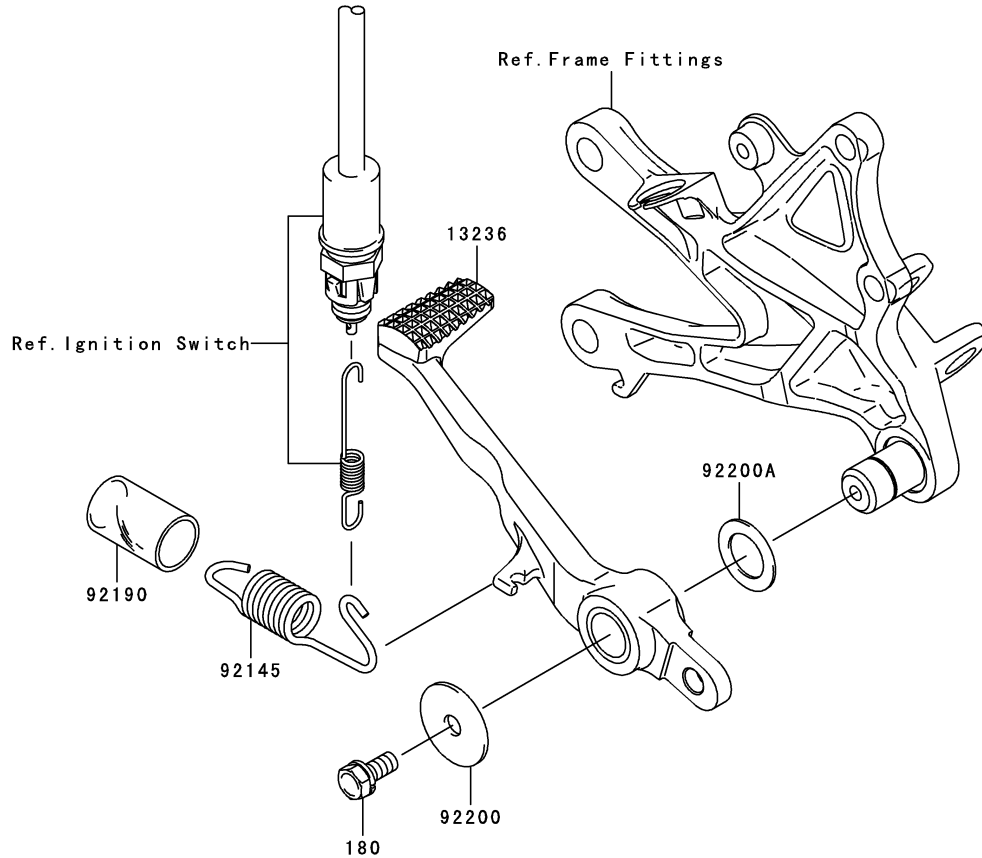

F2280

Ref. No.	Part No.	Description	Spec Code	Quantity-ZX1000			
				'08			
45014	45014-0189-23H	SHOCKABSORBER,SPG SIL+BODY GOL		1			
92092	92092-0003	BUSHING-RUBBER		1			

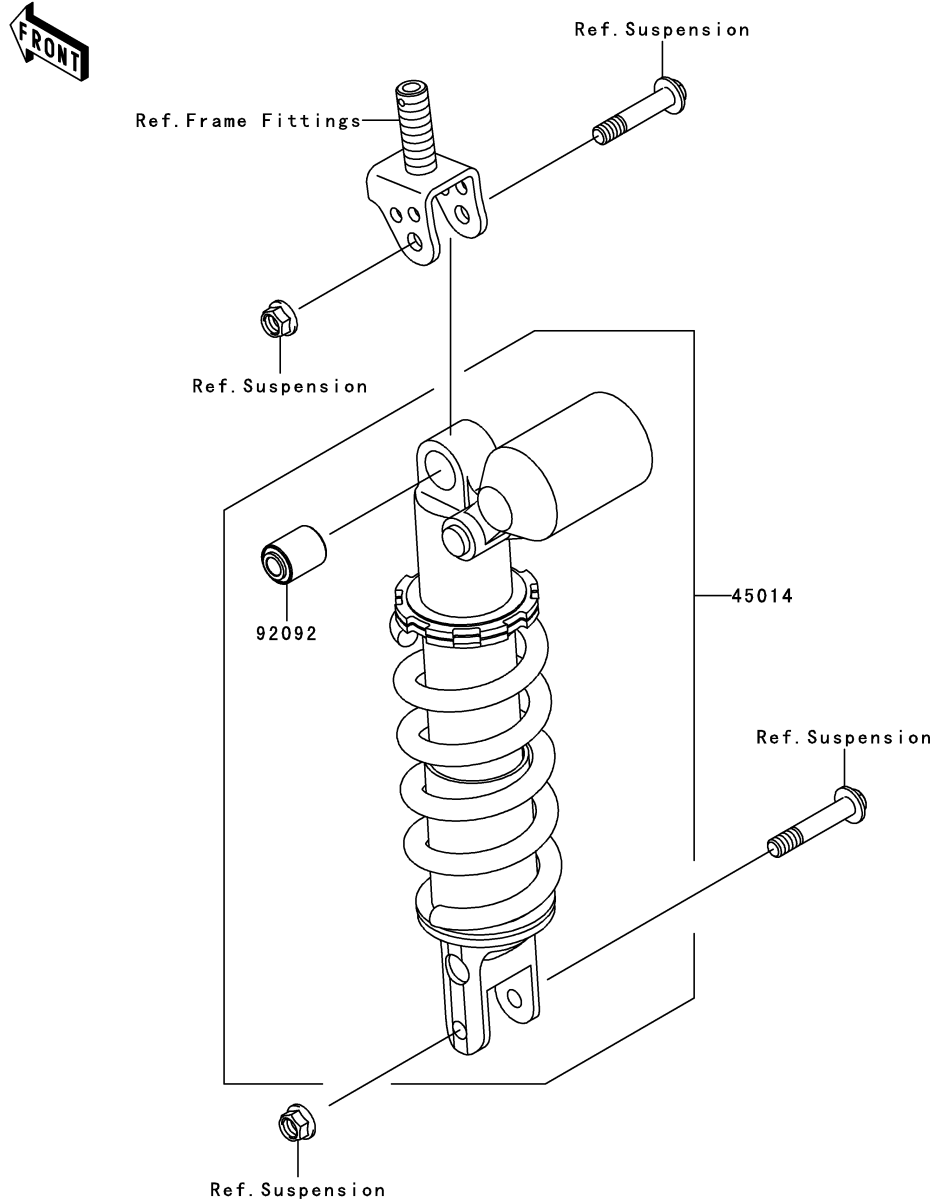

This catalog covers:

'08 ZX1000E8F Chassis

GRID NO.

F-5

This grid covers:

Front Master Cylinder

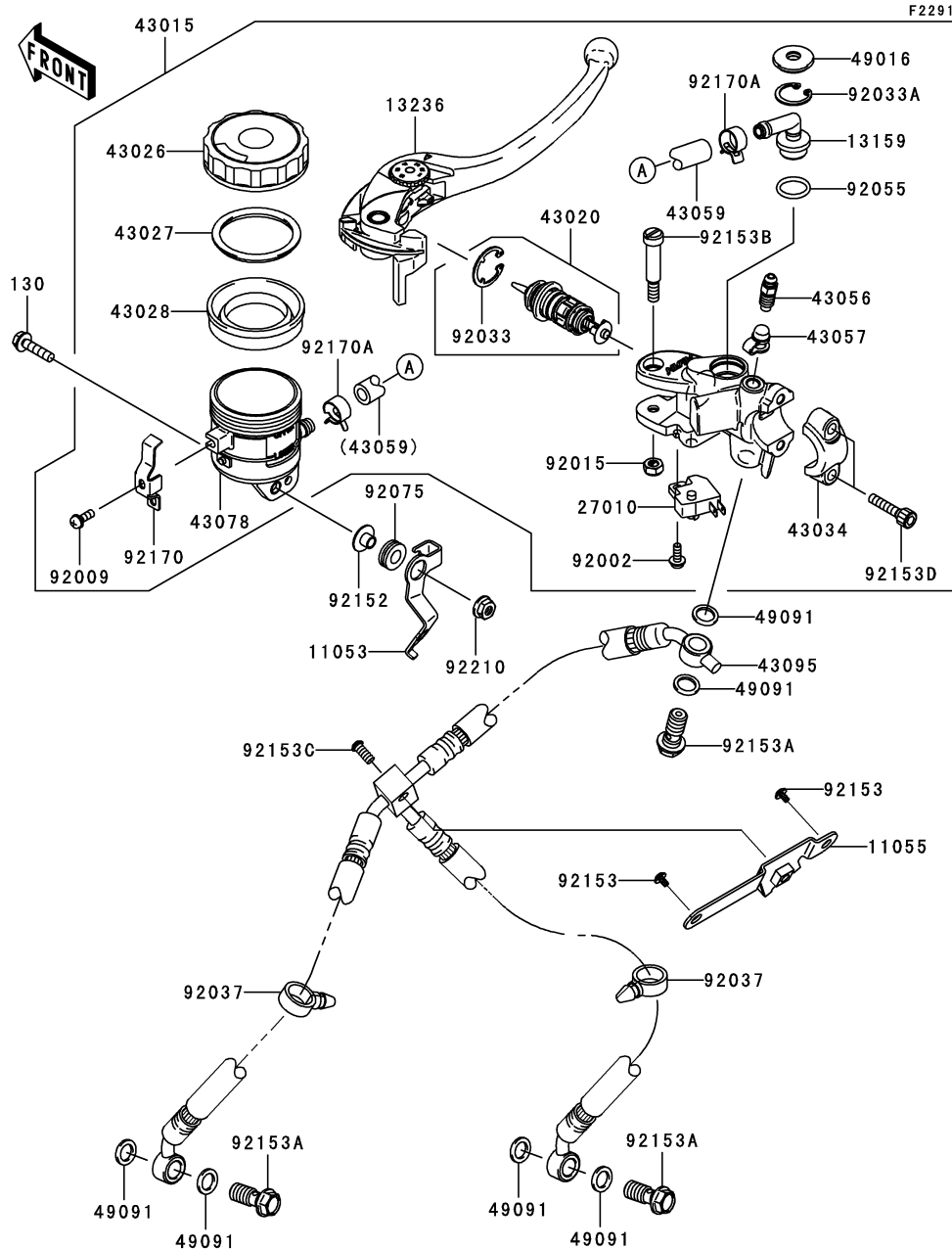

Ref. No.	Part No.	Description	Spec Code	Quantity-ZX1000			
				'08			
				E8F			
11053	11053-1545	BRACKET,RESERVOIR TANK,FR				1	
11055	11055-0319	BRACKET,BRAKE HOSE				1	
13159	13159-1061	CONNECTOR				1	
13236	13236-0103	LEVER-COMP,FRONT BRAKE				1	
27010	27010-0025	SWITCH,BRAKE				1	
43015	43015-0097	CYLINDER-ASSY-MASTER,FR				1	
43020	43020-0010	PISTON-COMP-BRAKE				1	
43026	43026-1051	CAP-BRAKE				1	
43027	43027-1051	PLATE-DIAPHRAGM				1	
43028	43028-1057	DIAPHRAGM,MASTER CYLINDER				1	
43034	43034-1016	HOLDER-BRAKE,MASTER CYLINDER				1	
43056	43056-1056	BREATHER-BRAKE				1	
43057	43057-1001	CAP-BREATHER				1	
43059	43059-1696	HOSE-BRAKE,FR MASTER CYLINDER				1	
43078	43078-1099	RESERVOIR				1	
43095	43095-0348	HOSE-BRAKE,FR				1	
49016	49016-1147	COVER-SEAL				1	
49091	49091-0001	WASHER-SEAL,10.1X14.5X1.5				6	
92002	92002-1323	BOLT,SCREW,4X12				1	
92009	92009-1570	SCREW				1	
92015	92015-1233	NUT,FLANGED,6MM,BLACK				1	
92033	92033-0034	RING-SNAP				1	
92033A	92033-1186	RING-SNAP,20.5MM				1	
92037	92037-1827	CLAMP,HOSE				2	
92055	92055-1251	RING-O,MASTER CYLINDER				1	
92075	92075-161	DAMPER				1	
92152	92152-0017	COLLAR				1	
92153	92153-0410	BOLT,SOCKET,6X10				2	
92153A	92153-0627	BOLT,OIL,L=23				3	
92153B	92153-0868	BOLT,LEVER				1	
92153C	92153-1267	BOLT,SOCKET,6X23				1	
92153D	92153-1518	BOLT,SOCKET,6X22				2	
92170	92170-1090	CLAMP				1	
92170A	92170-1091	CLAMP,HOSE				2	
92210	92210-0007	NUT,FLANGED,5MM				1	
130	130BB0520	BOLT-FLANGED,5X20				1	

This catalog covers:

'08 ZX1000E8F Chassis

GRID NO.

F-7

This grid covers:

Rear Master Cylinder

F2293

Ref. No.	Part No.	Description	Spec Code	Quantity-ZX1000	
				'08	E8F
11055	11055-1029	BRACKET,RESERVOIR TANK		1	
13159	13159-1056	CONNECTOR		1	
43010	43010-1062	ROD-ASSY-BRAKE		1	
43015	43015-0103	CYLINDER-ASSY-MASTER,RR		1	
43020	43020-1094	PISTON-COMP-BRAKE		1	
43026	43026-0009	CAP-BRAKE		1	
43027	43027-1053	PLATE-DIAPHRAGM		1	
43028	43028-1065	DIAPHRAGM		1	
43064	43064-006	GROMMET,HOSE CLAMP		1	
43078	43078-0040	RESERVOIR		1	
43095	43095-0350	HOSE-BRAKE,RR		1	
43095A	43095-0380	HOSE-BRAKE,RR MASTER CYLINDER		1	
49091	49091-0001	WASHER-SEAL,10.1X14.5X1.5		4	
92022	92022-1601	WASHER,CIRCRIP		1	
92033	92033-1186	RING-SNAP,20.5MM		1	
92039	92039-0067	RIVET		2	
92043	92043-0104	PIN,8X17		1	
92055	92055-1251	RING-O,MASTER CYLINDER		1	
92153	92153-0393	BOLT,SOCKET,8X30		2	
92153A	92153-0627	BOLT,OIL,L=23		2	
92153B	92153-0817	BOLT,SOCKET,6X16		1	
92170	92170-1091	CLAMP,HOSE		2	
92171	92171-0776	CLAMP,RESERVOIR TANK		1	
92171A	92171-1698	CLAMP,BRAKE HOSE		1	
92171B	92171-1699	CLAMP,BRAKE&RESERVOIR HOSE		1	
224	224AB0412	SCREW-PAN-WP-CROS,4X12		1	
550	550AA2015	PIN-COTTER,2.0X15		1	

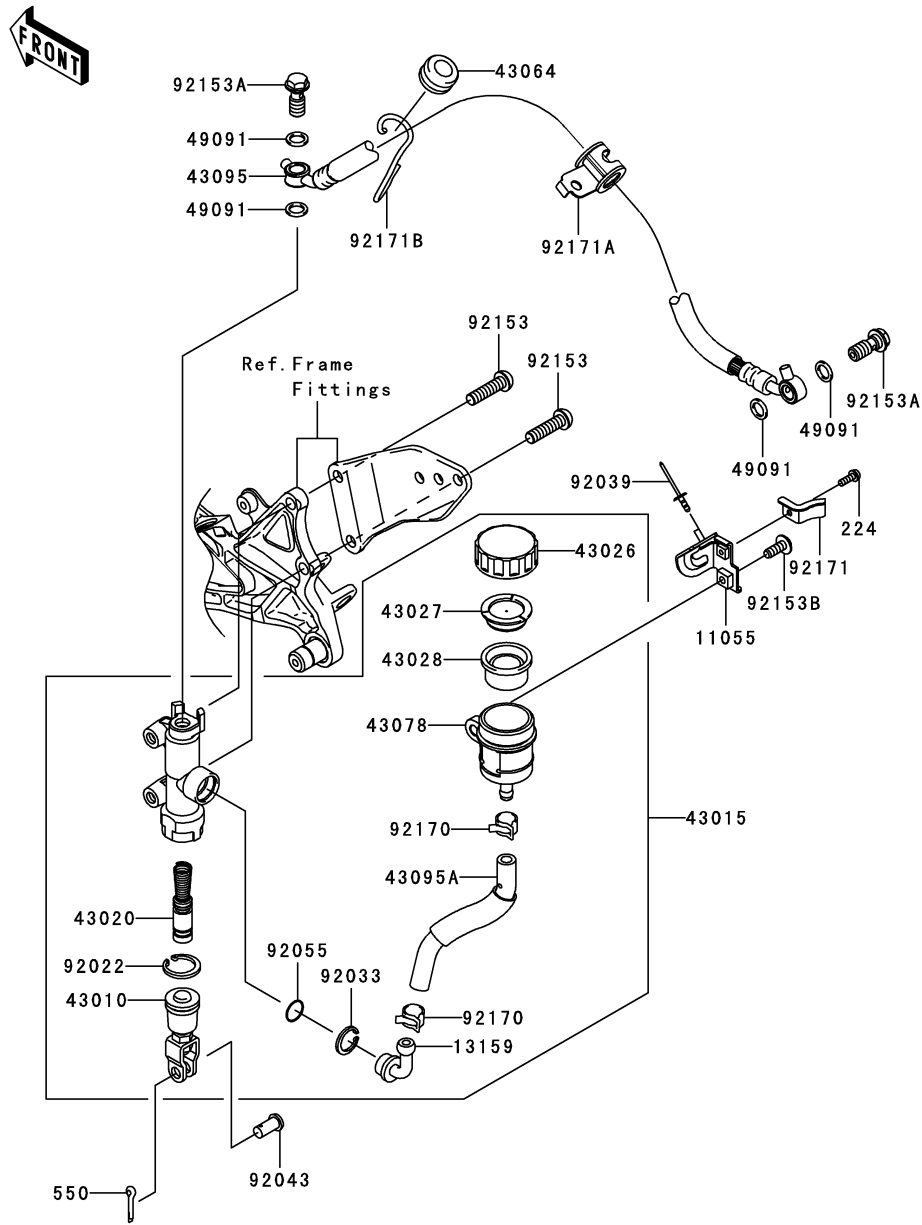

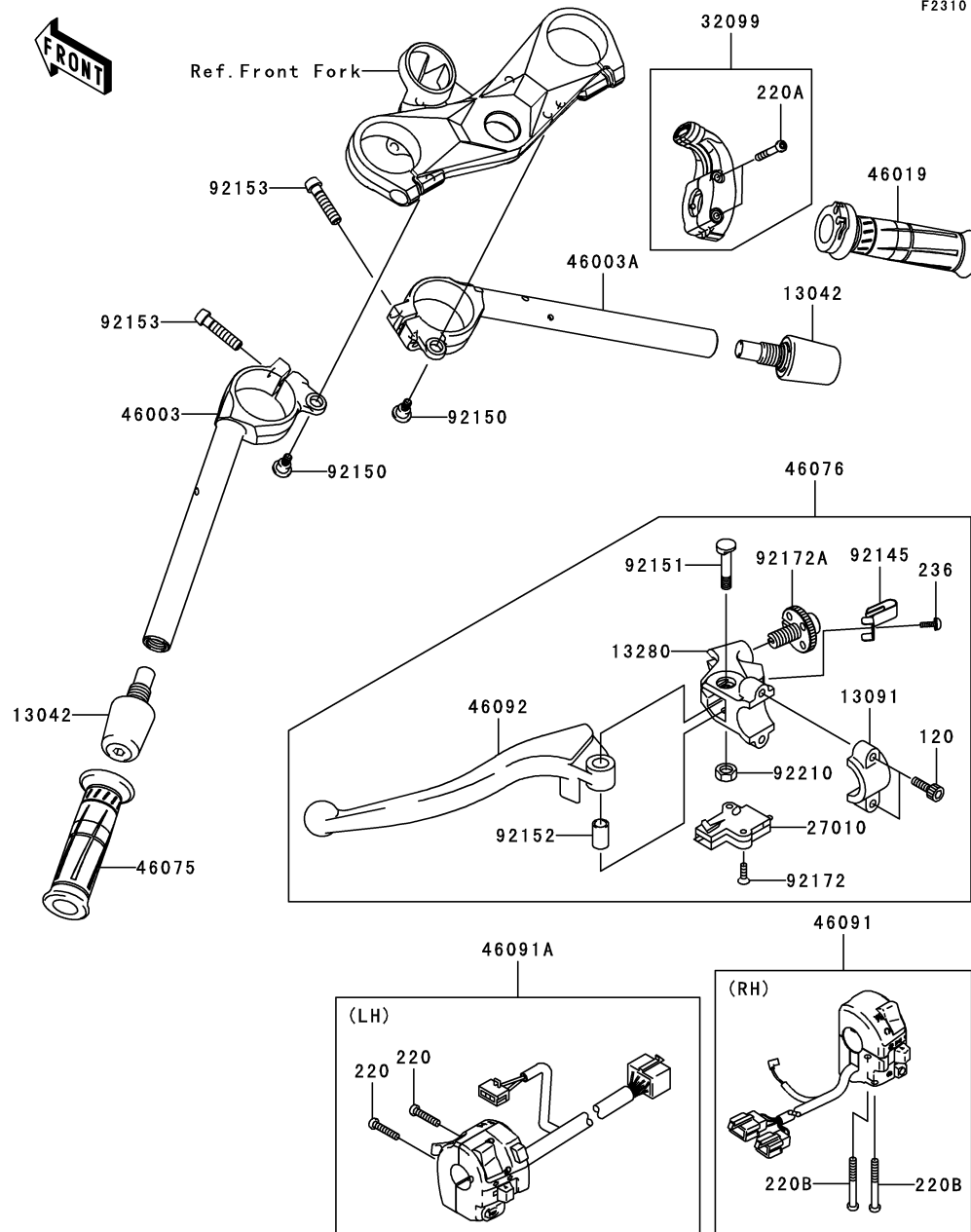

Ref. No.	Part No.	Description	Spec Code	Quantity-ZX1000			
				'08			
				E8F			
13042	13042-0029	WEIGHT,HANDLE					2
13091	13091-1624	HOLDER,CLUTCH LEVER					1
13280	13280-1160	HOLDER,CLUTCH LEVER					1
27010	27010-1492	SWITCH,CLUTCH					1
32099	32099-1193	CASE,THROTTLE CABLE					1
46003	46003-0144	HANDLE,LH					1
46003A	46003-0145	HANDLE,RH					1
46019	46019-0020	GRIP-ASSY,THROTTLE					1
46075	46075-0068	GRIP,LH					1
46076	46076-0033	LEVER-ASSY-GRIP,CLUTCH					1
46091	46091-0114	HOUSING-ASSY-CONTROL,RH					1
46091A	46091-0115	HOUSING-ASSY-CONTROL,LH					1
46092	46092-0006	LEVER-GRIP,CLUTCH					1
92145	92145-1286	SPRING					1
92150	92150-1090	BOLT,6MM					2
92151	92151-1523	BOLT					1
92152	92152-0103	COLLAR					1
92153	92153-0907	BOLT,SOCKET,8X35					2
92172	92172-0183	SCREW,3X16					2
92172A	92172-1060	SCREW,ADJUST NUT					1
92210	92210-0006	NUT,LOCK,6MM					1
120	120CA0620	BOLT-SOCKET,6X20					2
220	220AB0525	SCREW-PAN-CROS,5X25					2
220A	220AB0535	SCREW-PAN-CROSS,5X35					2
220B	220AB0545	SCREW-PAN-CROSS,5X45					2
236	236C0410	SCREW-PAN-WSP-CROS,4X10					1

This catalog covers:

'08 ZX1000E8F Chassis

GRID NO.

F-10

This grid covers:

Steering Damper

F2313

Ref. No.	Part No.	Description	Spec Code	Quantity-ZX1000		
				'08		
11054	11054-0023-18R	BRACKET,STEERING DAMPER,BLACK		1		
11054A	11054-1903	BRACKET,STEERING DAMPER		1		
44071	44071-0412	DAMPER-ASSY,STEERING		1		
92027	92027-1018	COLLAR,L=3.5		1		
92172	92172-0269	SCREW,8X26		2		
92200	92200-0293	WASHER		1		
130	130CB0618	BOLT-FLANGED,6X18		2		
410	410AA0800	WASHER-PLAIN-SMALL,8MM		1		

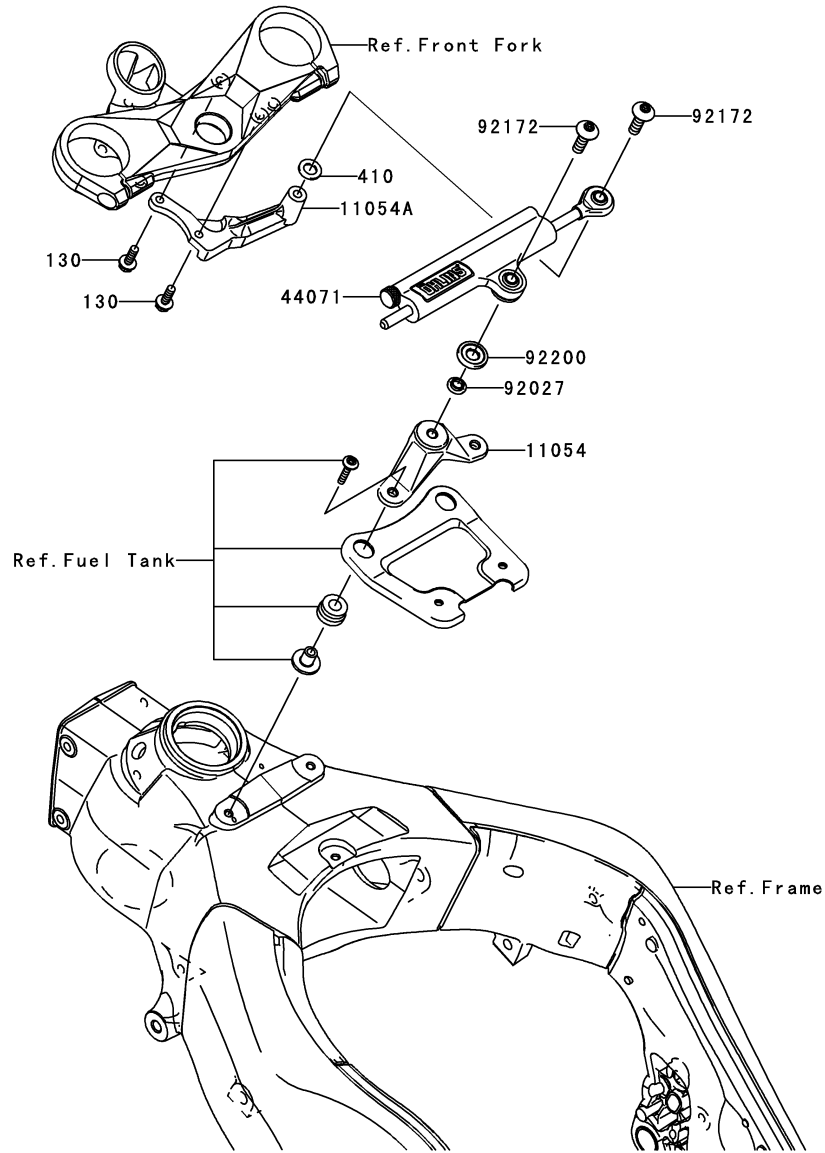

F2340

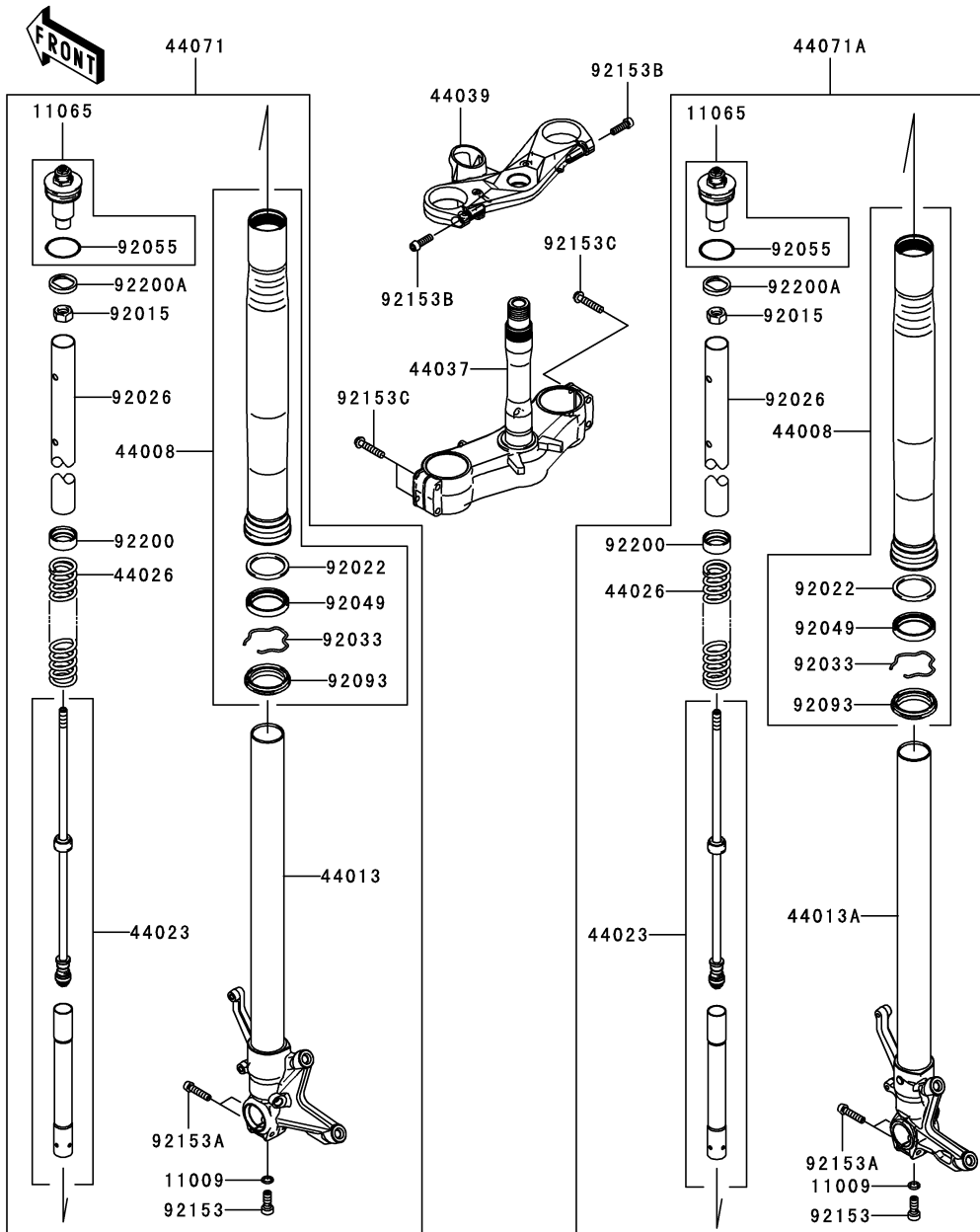

Ref. No.	Part No.	Description	Spec Code	Quantity-ZX1000	
				'08	E8F
11009	11009-1325	GASKET,PIPE-COMP-SUSP		2	
11065	11065-5001	CAP,FORK		2	
44008	44008-0041-828	PIPE-FORK OUTER,K.GOLD		2	
44013	44013-0105-18R	PIPE-FORK INNER,LH,F.S.BLACK		1	
44013A	44013-0106-18R	PIPE-FORK INNER,RH,F.S.BLACK		1	
44023	44023-0064	CYLINDER-SET-FORK		2	
44026	44026-0117	SPRING-FRONT FORK		2	
44037	44037-0079	HOLDER-FORK UNDER		1	
44039	44039-0069-499	HOLDER-FORK UPPER,A.BLACK		1	
44071	44071-5076	DAMPER-ASSY,FORK,LH,GOLD		1	
44071A	44071-5077	DAMPER-ASSY,FORK,RH,GOLD		1	
92015	92015-1795	NUT		2	
92022	92022-1299	WASHER		2	
92026	92026-0125	SPACER,FORK		2	
92033	92033-1077	RING-SNAP		2	
92049	92049-0072	SEAL-OIL		2	
92055	92055-0145	RING-O		2	
92093	92093-0058	SEAL,DUST		2	
92153	92153-0548	BOLT,SOCKET,10X25		2	
92153A	92153-1228	BOLT,SOCKET,8X35		4	
92153B	92153-1642	BOLT,SOCKET,8X25		2	
92153C	92153-1884	BOLT,FLANGED,8X40		4	
92200	92200-0420	WASHER		2	
92200A	92200-0443	WASHER		2	

F2510

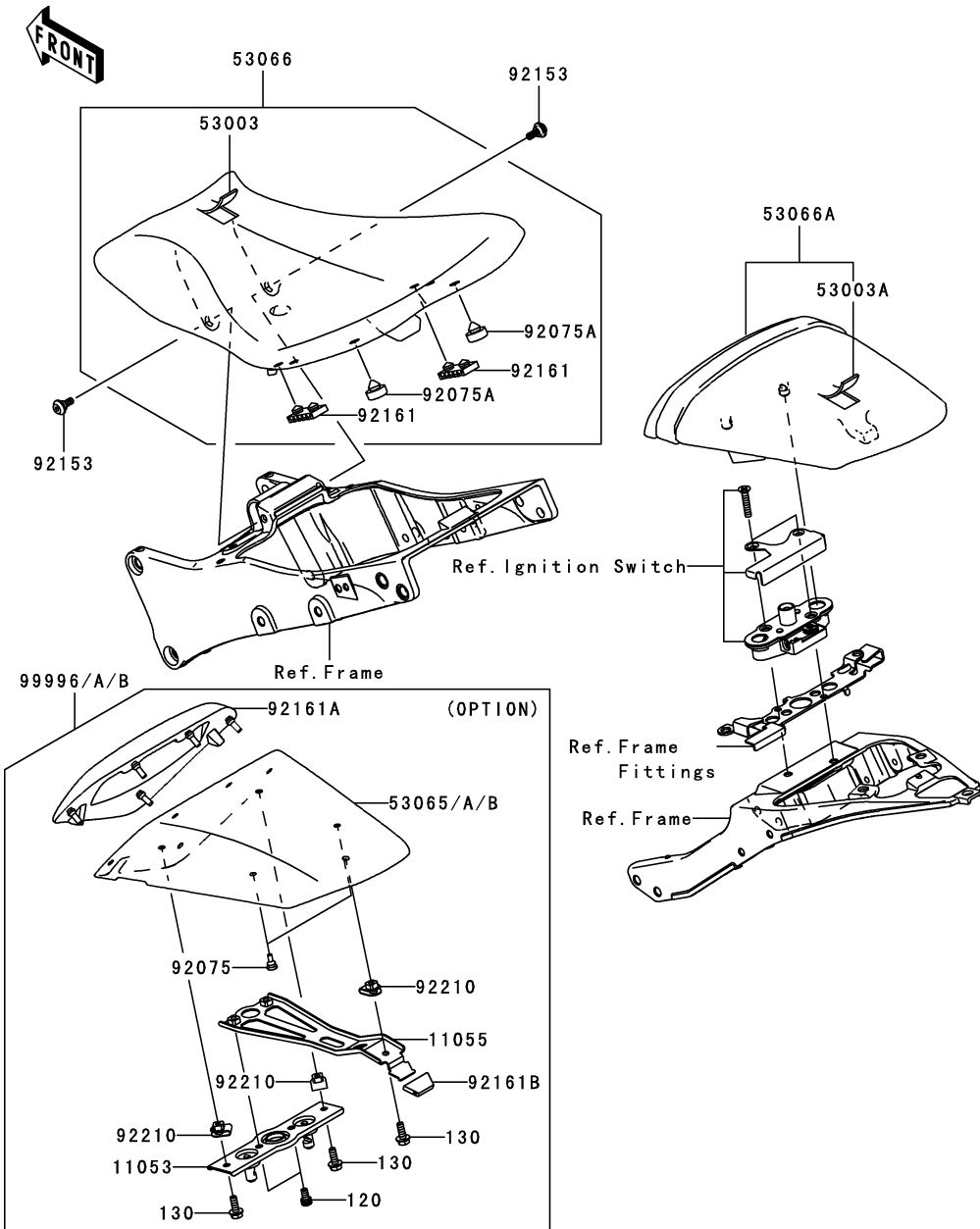

Ref. No.	Part No.	Description	Spec Code	Quantity-ZX1000		
				'08	E8F	
11053	11053-0386 (OPTION)	BRACKET		1		
11055	11055-0871 (OPTION)	BRACKET,SEAT COVER		1		
53003	53003-0120-MA	LEATHER,FRONT SEAT,BLACK		1		
53003A	53003-0121-MA	LEATHER,REAR SEAT,BLACK		1		
53065	53065-0016-17H (OPTION)	COVER SEAT,ORANGE		1		
53065A	53065-0016-17K (OPTION)	COVER SEAT,BLACK		1		
53065B	53065-0016-777 (OPTION)	COVER SEAT,GREEN		1		
53066	53066-0188-MA	SEAT-ASSY,FR,BLACK		1		
53066A	53066-0189-12Y	SEAT,RR,LEATHER BLK+BAND BLK		1		
92075	92075-1808 (OPTION)	DAMPER		2		
92075A	92075-1927	DAMPER		2		
92153	92153-0489	BOLT,SOCKET,6MM		2		
92161	92161-0149	DAMPER,SEAT		2		
92161A	92161-0627 (OPTION)	DAMPER,SEAT COVER		1		
92161B	92161-0629 (OPTION)	DAMPER		1		
92210	92210-0277 (OPTION)	NUT,6MM		3		
99996	99996-1358-17H (OPTION)	KIT,SINGLE SEAT COVER,ORANGE		1		
99996A	99996-1358-17K (OPTION)	KIT,SINGLE SEAT COVER,BLACK		1		
99996B	99996-1358-777 (OPTION)	KIT,SINGLE SEAT COVER,GREEN		1		
120	120CA0610 (OPTION)	BOLT-SOCKET,6X10		2		
130	130BA0616 (OPTION)	BOLT-FLANGED,6X16		3		

This catalog covers:
'08 ZX1000E8F Chassis

GRID NO. This grid covers:
F-14 Meter(s)

F2530

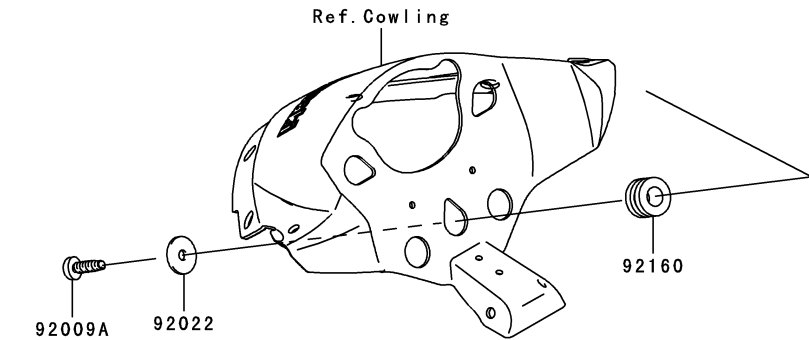
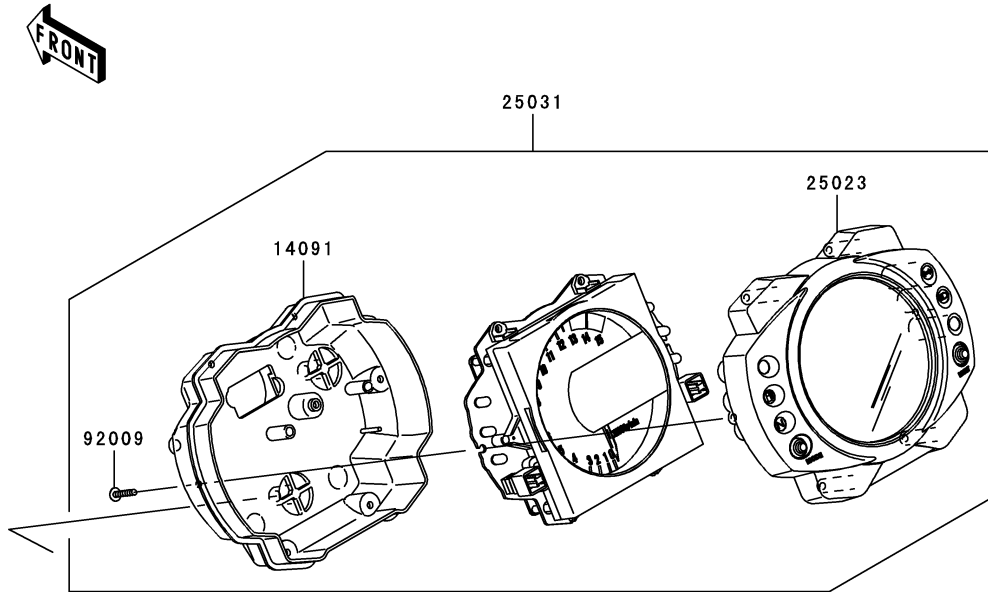

Ref. No.	Part No.	Description	Spec Code	Quantity-ZX1000		
				'08		

14091	14091-5430	COVER,METER,LWR		1
25023	25023-5001	COVER-METER CASE,UPP		1
25031	25031-0201	METER-ASSY,SPEEDO		1
92009	92009-1164	SCREW,TAPPING,3X16		7
92009A	92009-1197	SCREW,TAPPING,5X14		3
92022	92022-1405	WASHER,5.5X20X1.2		3
92160	92160-1167	DAMPER		3

This catalog covers:

'08 ZX1000E8F Chassis

GRID NO.

G-3

This grid covers:

Cables

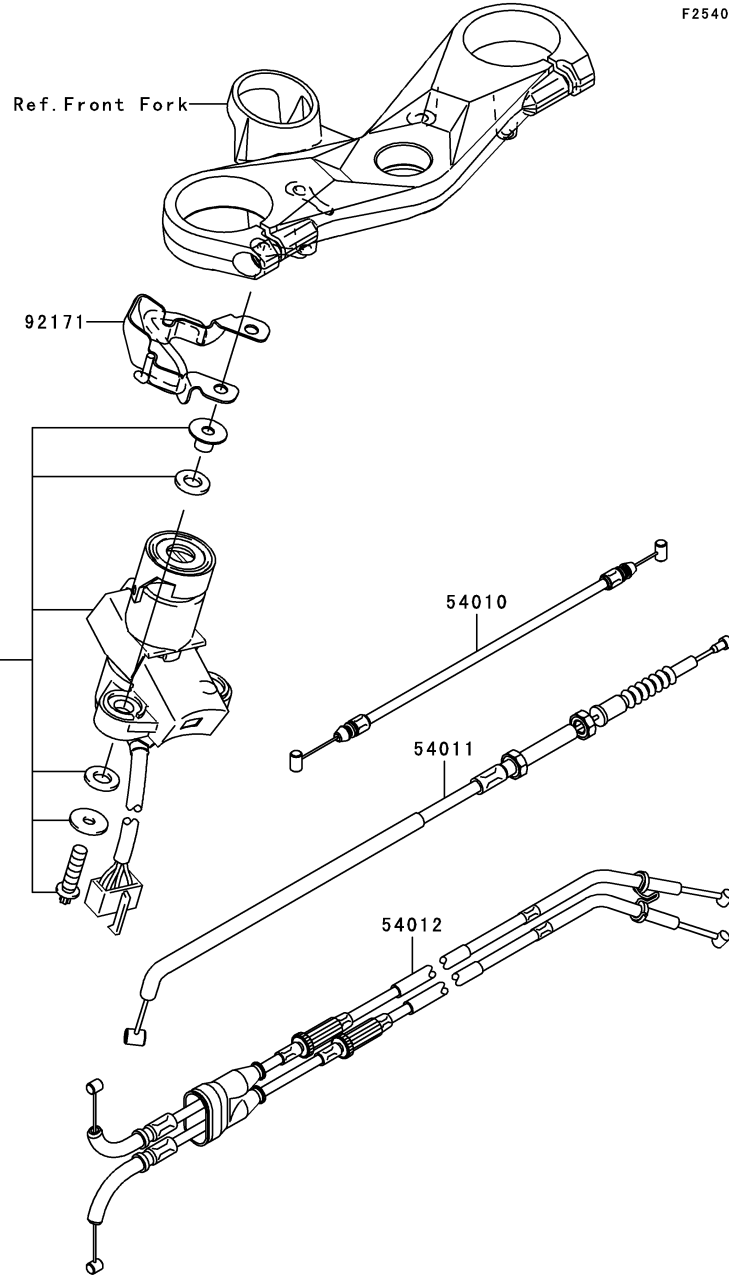

F2540

Ref. No.	Part No.	Description	Spec Code	Quantity-ZX1000			
				'08			
54010	54010-0074	CABLE,SEAT LOCK				1	
54011	54011-0080	CABLE-CLUTCH				1	
54012	54012-0221	CABLE-THROTTLE				1	
92171	92171-0675	CLAMP,CABLE				1	

F2710

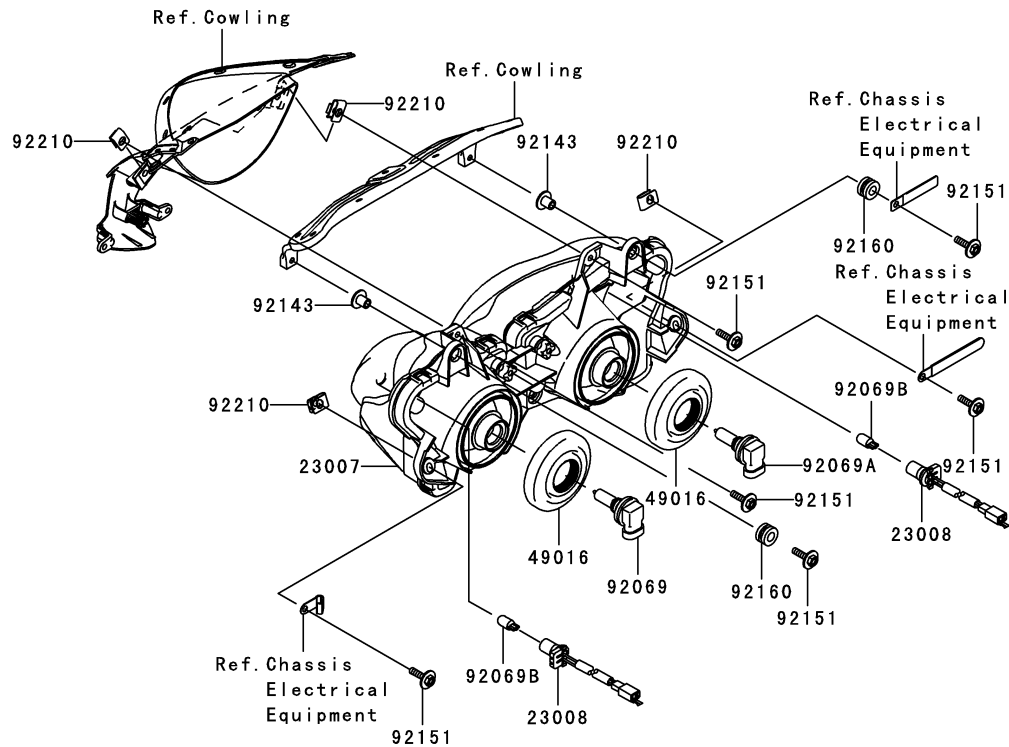

Ref. No.	Part No.	Description	Spec Code	Quantity-ZX1000			
				'08			

23007	23007-0101	LENS-COMP,HEAD LAMP		1
23008	23008-0090	SOCKET-ASSY,HEAD LAMP		2
49016	49016-0023	COVER-SEAL,HEAD LAMP		2
92069	92069-0007	BULB,12V 65W,H9		1
92069A	92069-0014	BULB,12V 55W,H11		1
92069B	92069-1016	BULB,12V 5W		2
92143	92143-1353	COLLAR		2
92151	92151-1241	BOLT,6X25		6
92160	92160-1167	DAMPER		2
92210	92210-0130	NUT		4

This catalog covers:
'08 ZX1000E8F Chassis

GRID NO. **G-6** This grid covers:
Taillight(s)

F2720

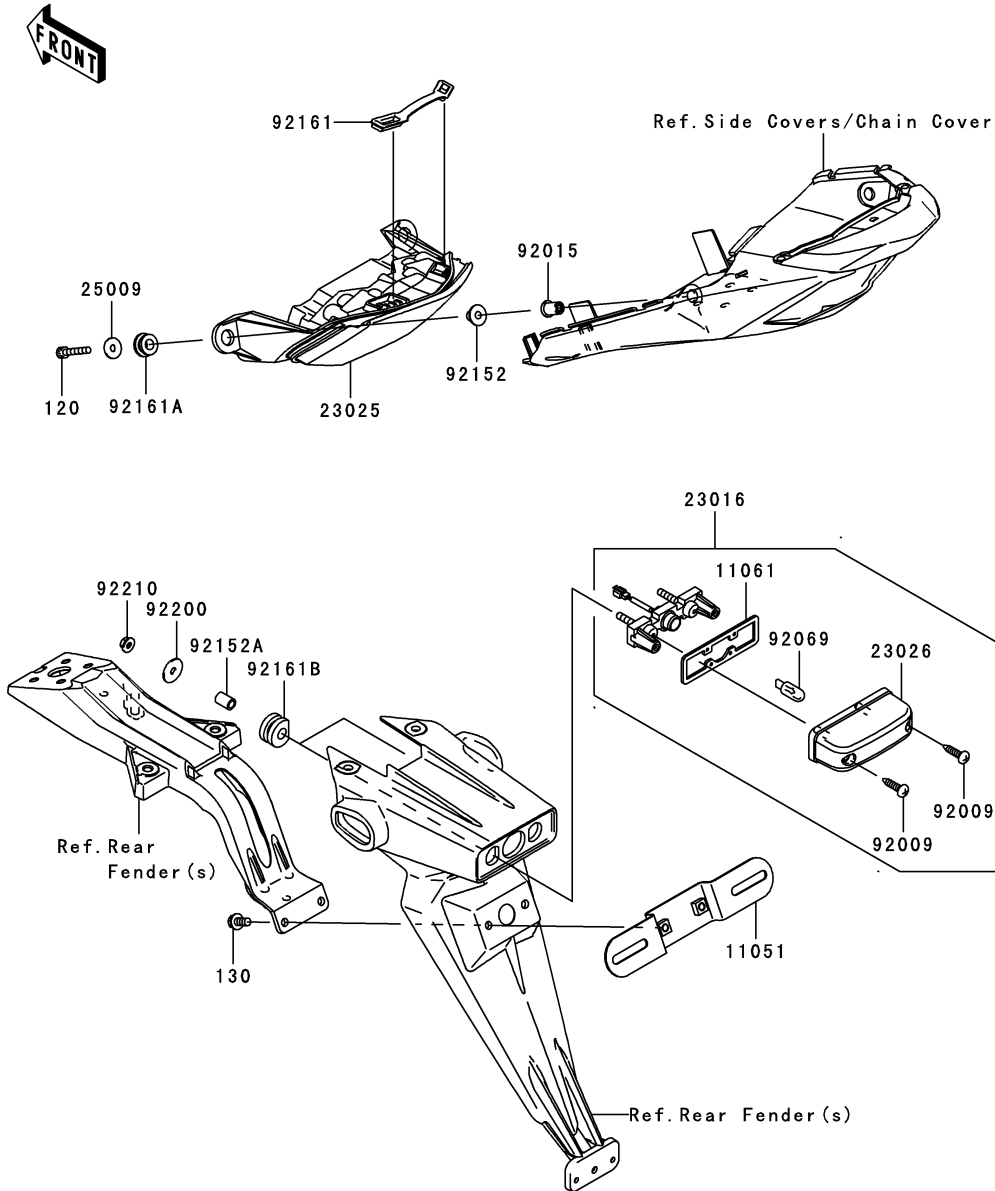

Ref. No.	Part No.	Description	Spec Code	Quantity-ZX1000		
				'08	E8F	
11051	11051-1503	BRACKET,LICENSE			1	
11061	11061-0329	GASKET,LICENSE LAMP			1	
23016	23016-0020	LAMP-ASSY,LICENSE			1	
23025	23025-0027	LAMP-TAIL			1	
23026	23026-0014	LENS,LICENSE LAMP			1	
25009	25009-004	WASHER,5.2X16X1.2			2	
92009	92009-1605	SCREW,TAPPING,4X16			2	
92015	92015-1757	NUT,WELL,5MM			2	
92069	92069-1016	BULB,12V 5W			1	
92152	92152-0092	COLLAR			2	
92152A	92152-0617	COLLAR,6X9X13.3			2	
92161	92161-0191	DAMPER, TAIL LAMP			1	
92161A	92161-0317	DAMPER			2	
92161B	92161-1313	DAMPER			2	
92200	92200-0284	WASHER,5.5X20X1.2			2	
92210	92210-0007	NUT,FLANGED,5MM			2	
120	120CA0522	BOLT-SOCKET,5X22			2	
130	130CA0616	BOLT-FLANGED,6X16			2	

This catalog covers:

'08 ZX1000E8F Chassis

GRID NO.

G-8

This grid covers:

Chassis Electrical Equipment

F2760

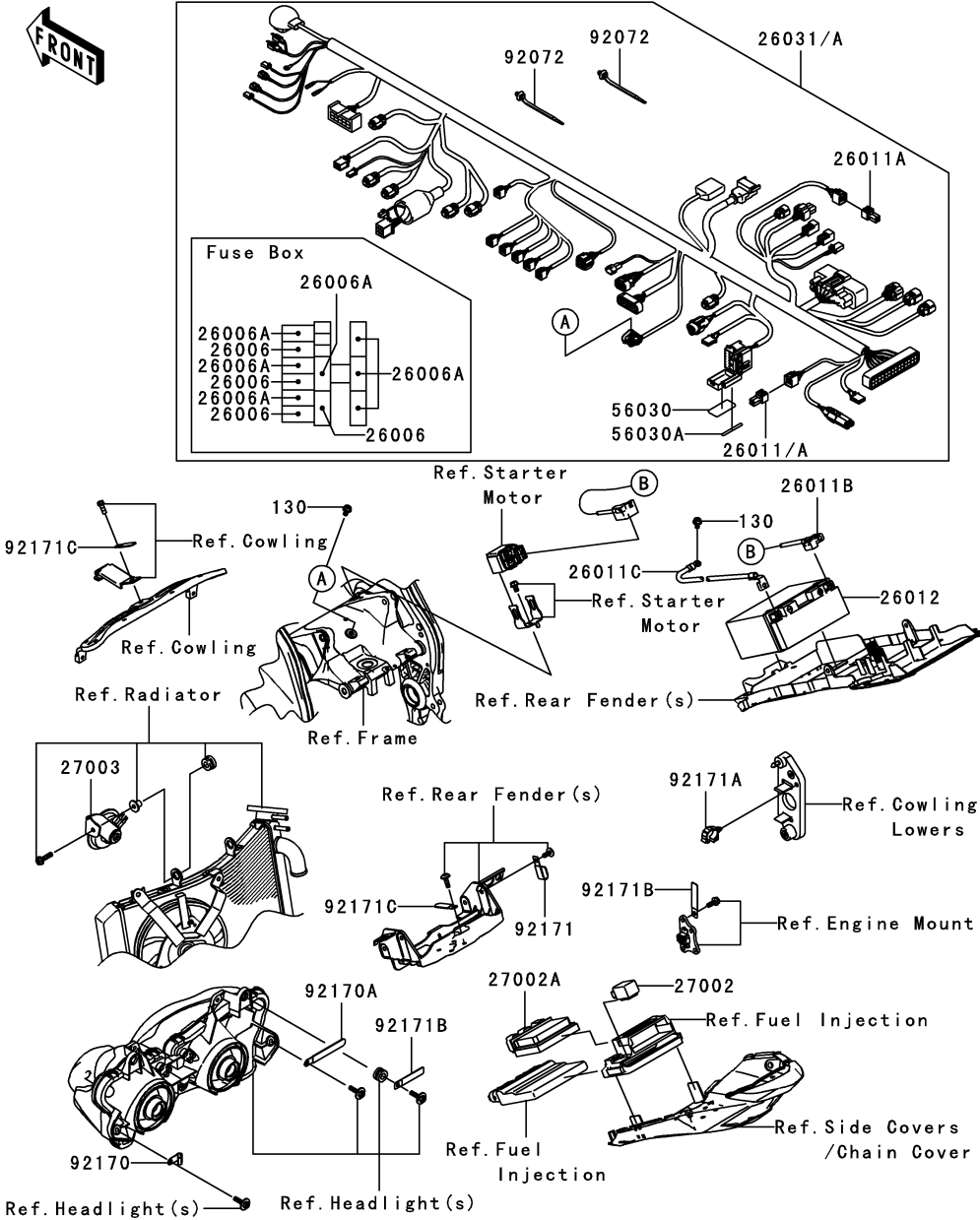

Ref. No.	Part No.	Description	Spec Code	Quantity-ZX1000		
				'08		
26006	26006-0001	FUSE,15A				4
26006A	26006-1078	FUSE,10A				7
26011	26011-0036	WIRE-LEAD				
		L-----	FR			1
26011A	26011-0082	WIRE-LEAD				
		L-----	FR			1
		L-----	UK,WV			2
26011B	26011-0167	WIRE-LEAD,BATTERY(+)				1
26011C	26011-0168	WIRE-LEAD,BATTERY(-)				1
26012	26012-0036	BATTERY,YT12B-BS,12V 12AH				1
26031	26031-0574	HARNES,MAIN				
		L-----	UK,WV			1
26031A	26031-0674	HARNES,MAIN				
		L-----	FR			1
27002	27002-0006	RELAY-ASSY,SIGNAL LAMP				1
27002A	27002-0007	RELAY-ASSY				1
27003	27003-0052	HORN				1
56030	56030-0185	LABEL,FUSE BOX				1
56030A	56030-0186	LABEL,FUSE BOX				1
92072	92072-1414	BAND				2
92170	92170-1900	CLAMP,HARNES				1
92170A	92170-1925	CLAMP				1
92171	92171-0305	CLAMP				1
92171A	92171-0316	CLAMP,BRAKE HOSE				1
92171B	92171-0652	CLAMP				2
92171C	92171-0779	CLAMP				2
130	130BA0610	BOLT-FLANGED,6X10				2

This catalog covers:

'08 ZX1000E8F Chassis

GRID NO.

G-9

This grid covers:

Ignition Switch

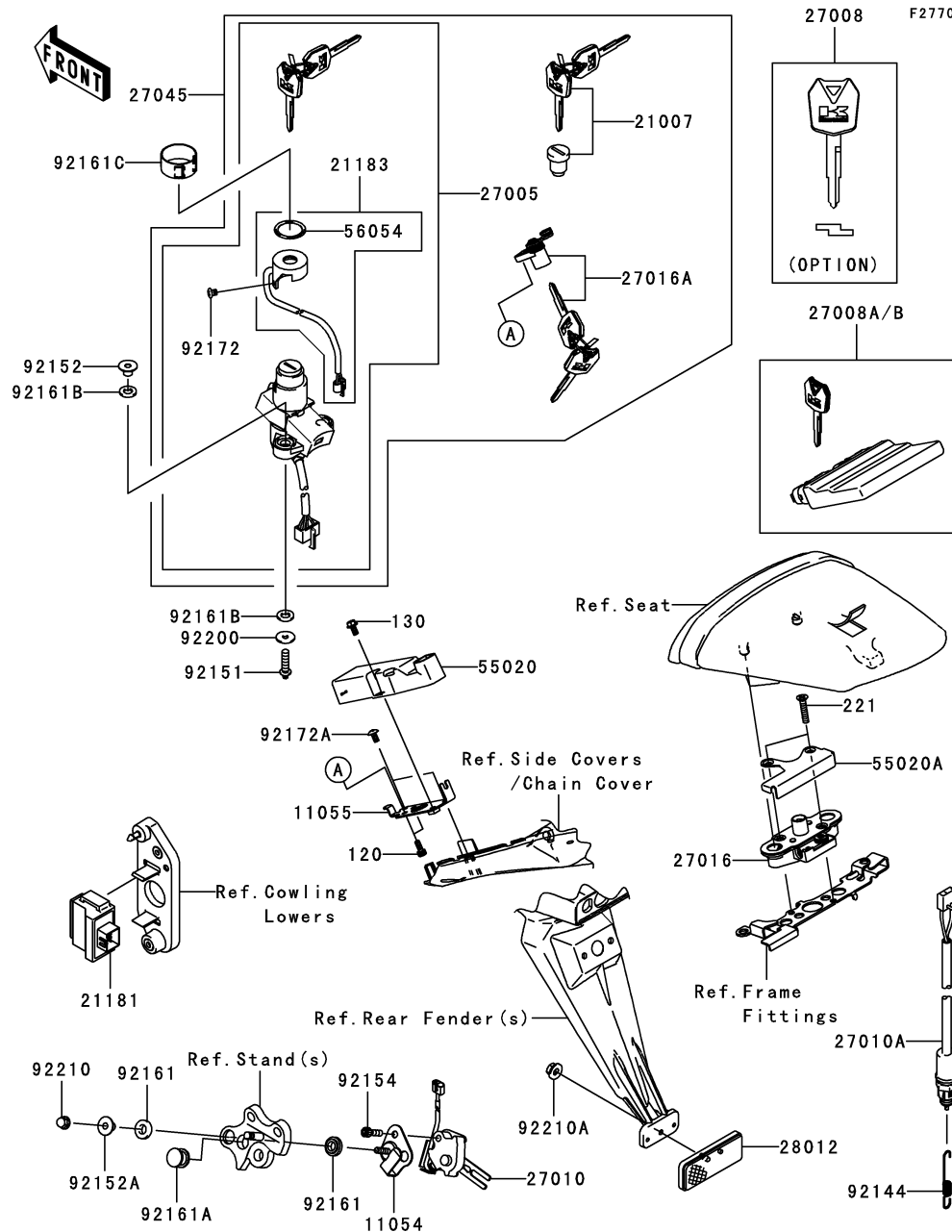

Ref. No.	Part No.	Description	Spec Code	Quantity-ZX1000		
				'08	E8F	
11054	11054-1904	BRACKET,SIDE STAND SWITCH			1	
11055	11055-0316	BRACKET,SEAT LOCK			1	
21007	21007-5056	ROTOR,LOCK,TANK CAP			1	
21181	21181-0004	AMPLIFIER,IMMOBI			1	
21183	21183-0004	ANTENNA,IMMOBI			1	
27005	27005-5145	SWITCH-ASSY-IGNITION			1	
27008	27008-0029	KEY-LOCK,BLANK,IMMOBI,SUB			1	
	(OPTION)					
27008A	27008-5047	MASTER KEY SET(BLANK),IMMOBI				
	L-----		UK,WV		1	
27008B	27008-5048	MASTER KEY SET(BLANK),IMMOBI				
	L-----		FR		1	
27010	27010-0064	SWITCH,SIDE STAND			1	
27010A	27010-1486	SWITCH,REAR BRAKE			1	
27016	27016-0003	LOCK-ASSY,SEAT STRIKER			1	
27016A	27016-5310	LOCK-ASSY,SEAT			1	
27045	27045-5388	SWITCH-ASSY			1	
28012	28012-1077	REFLECTOR-REFLEX			1	
55020	55020-0411	GUARD,SEAT LOCK			1	
55020A	55020-0447	GUARD,SEAT STRIKER			1	
56054	56054-0161	MARK,IMMOBI			1	
92144	92144-1139	SPRING,BRAKE LAMP SWITCH			1	
92151	92151-1946	BOLT,TORX,6X22			2	
92152	92152-0352	COLLAR			2	
92152A	92152-1074	COLLAR			1	
92154	92154-0031	BOLT,SOCKET,6X22			1	
92161	92161-0117	DAMPER			2	
92161A	92161-0118	DAMPER			1	
92161B	92161-0240	DAMPER,IGNITION SWITCH			4	
92161C	92161-0257	DAMPER,IGNITION SWITCH			1	
92172	92172-0188	SCREW,4X8			2	
92172A	92172-1061	SCREW,TAPPING,5X10			2	
92200	92200-0212	WASHER,6X20X1.6			2	
92210	92210-0003	NUT,CAP,6MM			1	
92210A	92210-0007	NUT,FLANGED,5MM			1	
120	120CB0512	BOLT-SOCKET,5X12			2	
130	130AA0510	BOLT-FLANGED,5X10			1	
221	221AB0635	SCREW-CSK-CROSS,6X35			2	

F2810

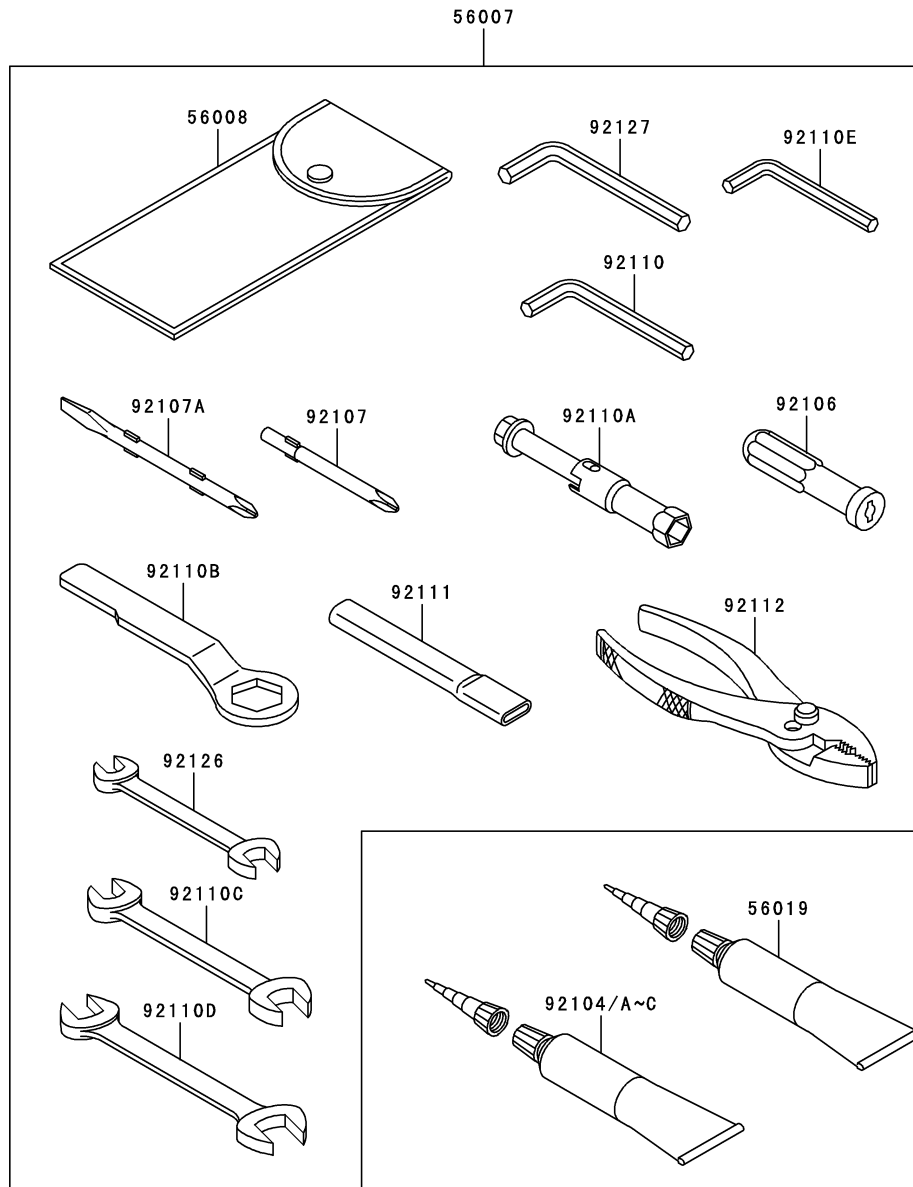

Ref. No.	Part No.	Description	Spec Code	Quantity-ZX1000			
				'08			
56007	56007-0051	TOOL-KIT					1
56008	56008-1075	BAG,TOOL					1
56019	56019-120	THREE BOND TB1211,HT/RS,WHITE					1
92104	92104-0002	GASKET-LIQUID,SUPER-X,NO.8008					1
92104A	92104-0004	GASKET-LIQUID,TB1211F					1
92104B	92104-1062	GASKET-LIQUID,BLACK TB1215B					1
92104C	92104-1064	GASKET-LIQUID,BLACK TB1216B					1
92106	92106-1001	GRIP-SCREW DRIVER					1
92107	92107-005	TOOL-DRIVER,#3PHILLIPS					1
92107A	92107-1051	TOOL-DRIVER,#2PHILLIPS&SLOT					1
92110	92110-1015	TOOL-WRENCH,ALLEN,5MM					1
92110A	92110-1132	TOOL-WRENCH,BOX,16MM					1
92110B	92110-1147	TOOL-WRENCH,BOX END,27MM					1
92110C	92110-1152	TOOL-WRENCH,OPEN END,10X12					1
92110D	92110-1153	TOOL-WRENCH,OPEN END,14X17					1
92110E	92110-3703	TOOL-WRENCH,ALLEN,4MM					1
92111	92111-1051	TOOL-BAR,BOX END WRENCH					1
92112	92112-1001	TOOL-PLIERS					1
92126	92126-004	TOOL-WRENCH,OPEN END,8X10					1
92127	92127-003	TOOL-WRENCH,ALLEN,6MM					1

This catalog covers:

'08 ZX1000E8F Chassis

GRID NO.

G-11

This grid covers:

Labels

F2860

Ref. No.	Part No.	Description	Spec Code	Quantity-ZX1000			
				'08			

56030	56030-1211	LABEL,GASOLINE		1
56031	56031-1441	LABEL-MANUAL,ENGLISH/FRENCH		1
		L-----FR,WV		1
56033	56033-0232	LABEL-MANUAL,DAILY SAFETY		1
56033A	56033-0234	LABEL-MANUAL,CHAIN		1
56053	56053-0270	LABEL-SPECIFICATION,TIRE&LOAD		1
56070	56070-1143	LABEL,UNLEADED PETROL ONLY		1

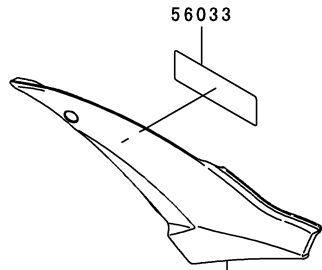
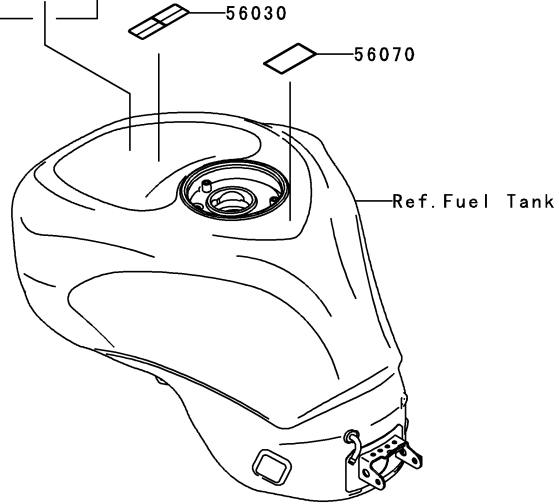
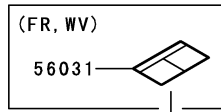

Ref. Side Covers/Chain Cover

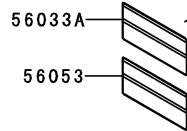
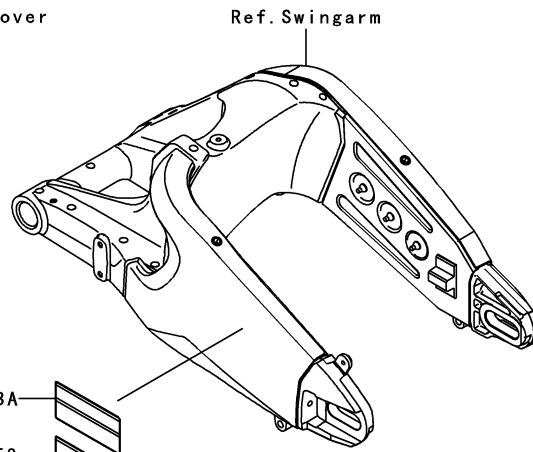

This catalog covers:

'08 ZX1000E8F Chassis

GRID NO.

G-12

This grid covers:

Decals(Green)

F2861

Ref. No.	Part No.	Description	Spec Code	Quantity-ZX1000			
				'08			
56054	56054-0164	MARK,FUEL TANK,LH,KAWASAKI					
56054A	56054-0165	MARK,FUEL TANK,RH,KAWASAKI					
56054B	56054-0166	MARK,TAIL COVER,ZX-10R					
56054C	56054-0167	MARK,UPP COWLING,NINJA					

56054	56054-0164	MARK,FUEL TANK,LH,KAWASAKI	1
56054A	56054-0165	MARK,FUEL TANK,RH,KAWASAKI	1
56054B	56054-0166	MARK,TAIL COVER,ZX-10R	2
56054C	56054-0167	MARK,UPP COWLING,NINJA	2

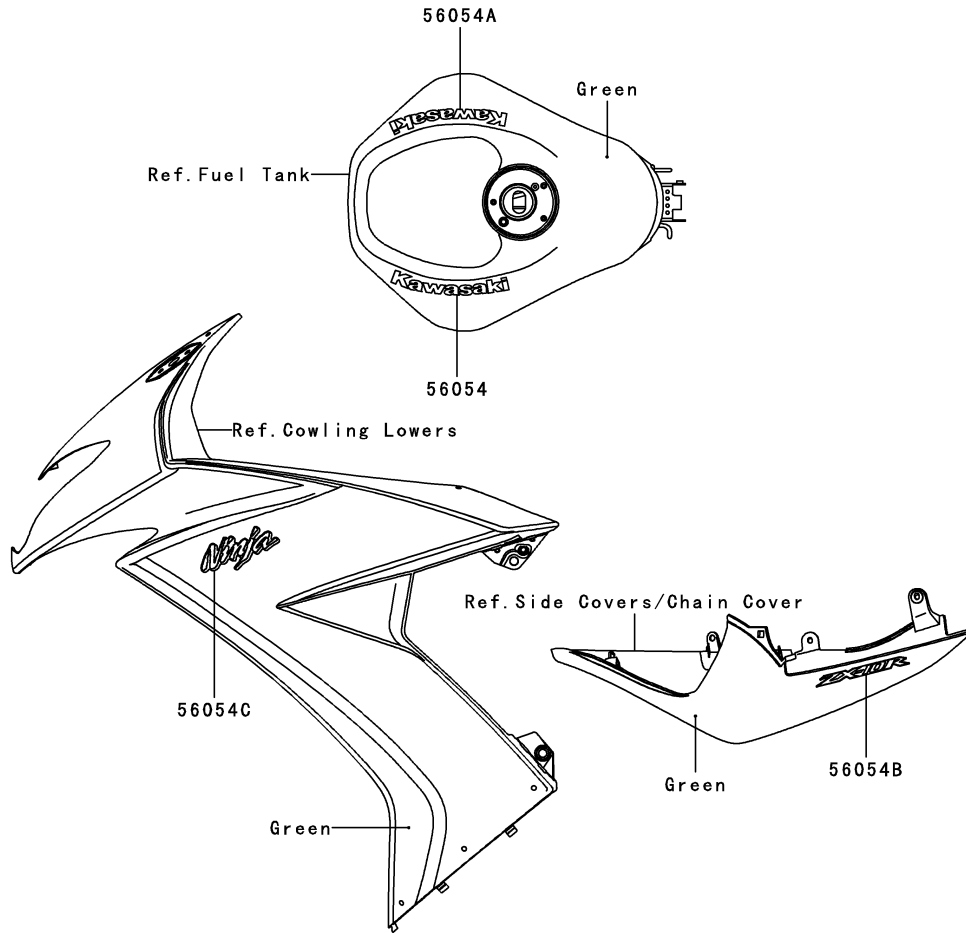

This catalog covers:

'08 ZX1000E8F Chassis

GRID NO.

G-13

This grid covers:

Decals(Black)

F2861A

Ref. No.	Part No.	Description	Spec Code	Quantity-ZX1000			
				'08			
56054	56054-0168	MARK,FUEL TANK,LH,KAWASAKI					
56054A	56054-0169	MARK,FUEL TANK,RH,KAWASAKI					
56054B	56054-0170	MARK,TAIL COVER,ZX-10R					
56054C	56054-0171	MARK,UPP COWLING,NINJA					

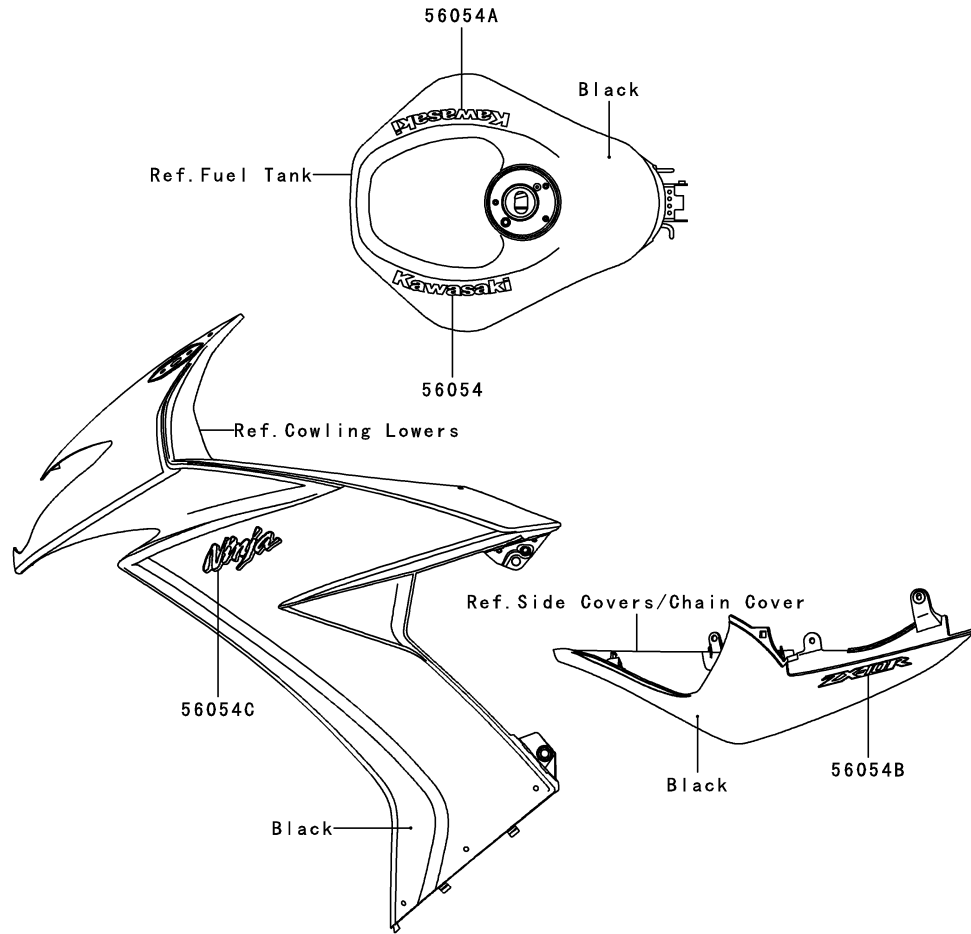

This catalog covers:

'08 ZX1000E8F Chassis

GRID NO.

G-14

This grid covers:

Decals(Orange)

F2861B

Ref. No.	Part No.	Description	Spec Code	Quantity-ZX1000			
				'08			
56054	56054-0164	MARK,FUEL TANK,LH,KAWASAKI					1
56054A	56054-0165	MARK,FUEL TANK,RH,KAWASAKI					1
56054B	56054-0167	MARK,UPP COWLING,NINJA					2
56054C	56054-0172	MARK,TAIL COVER,ZX-10R					2

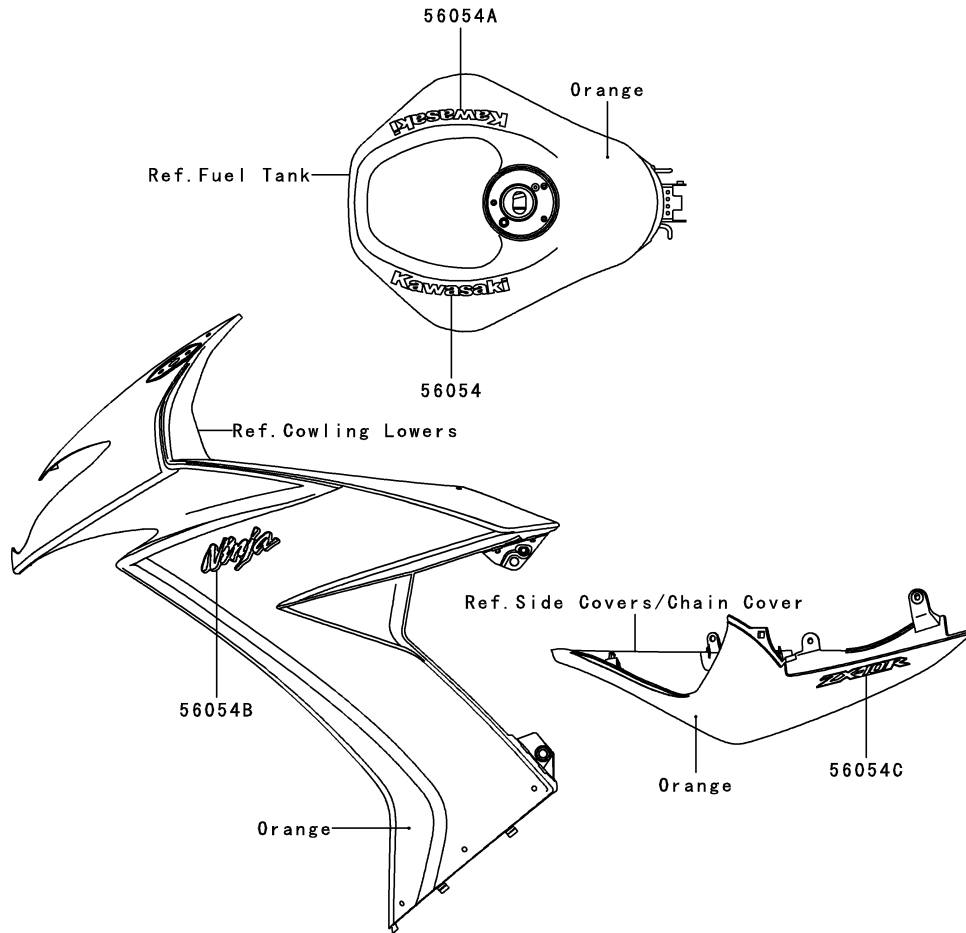

This catalog covers:

'08 ZX1000E8F Chassis

GRID NO.

H-3

This grid covers:

Cowling

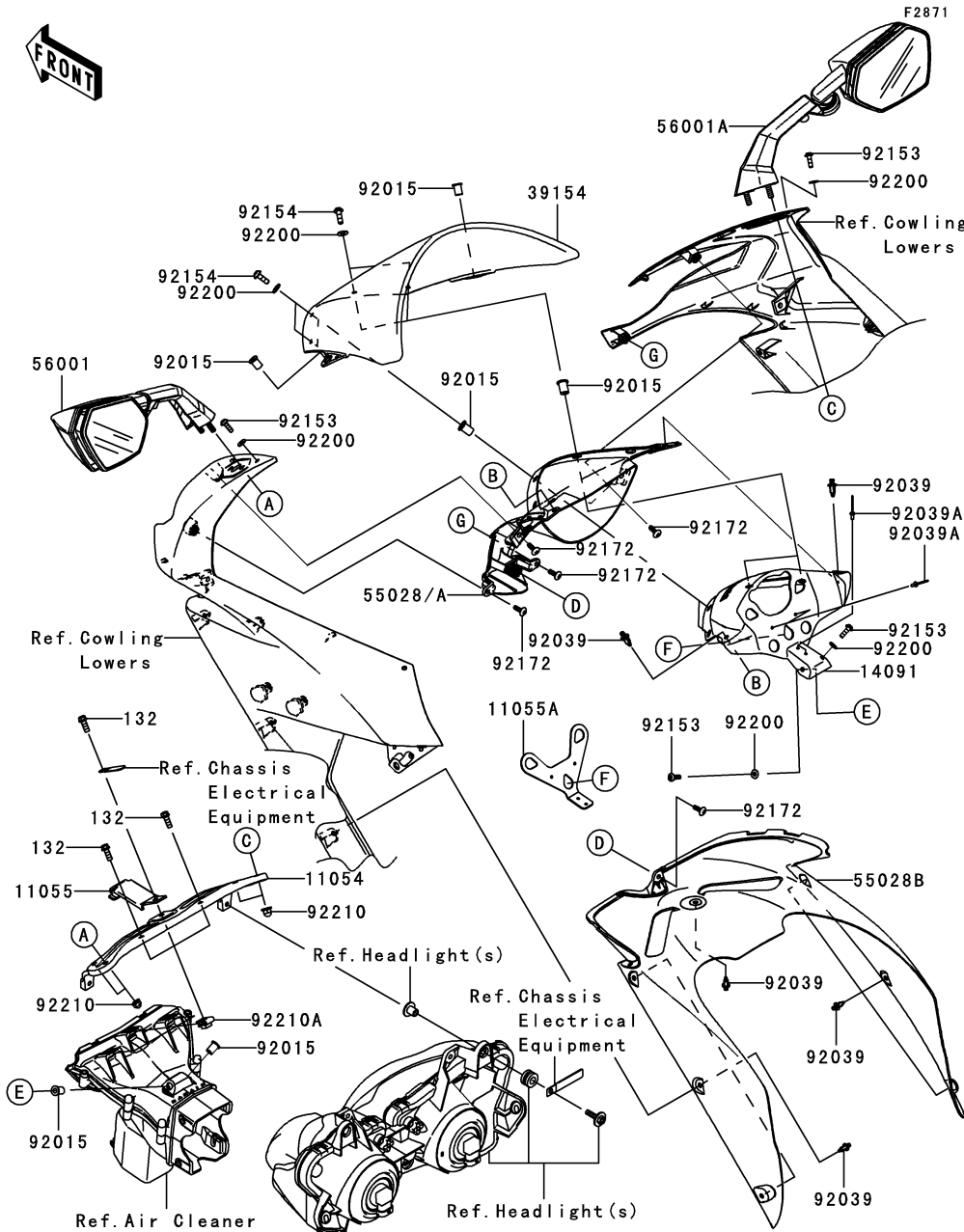

Ref. No.	Part No.	Description	Spec Code	Quantity-ZX1000		
				'08	E8F	
11054	11054-1905	BRACKET,MIRROR&METER STAY	1			
11055	11055-1026	BRACKET	1			
11055A	11055-1027	BRACKET	1			
14091	14091-0878-839	COVER,METER,S.BLACK	1			
39154	39154-0030	WINDSHIELD	1			
55028	55028-0228-11J	COWLING,UPP,CNT,F.S.BLACK	1			
55028A	55028-0228-17K	COWLING,UPP,CNT,M.D,BLACK	1			
55028B	55028-0264-839	COWLING,FR,S.BLACK	1			
56001	56001-0102	MIRROR-ASSY,LH	1			
56001A	56001-0103	MIRROR-ASSY,RH	1			
92015	92015-1757	NUT,WELL,5MM	8			
92039	92039-0068	RIVET	9			
92039A	92039-1234	RIVET	4			
92153	92153-1244	BOLT,SOCKET,5X16	4			
92154	92154-0026	BOLT,SOCKET,5X16	4			
92172	92172-0175	SCREW,TAPPING,5X16	5			
92200	92200-0006	WASHER,NYLONE,5.3X11.5X0.5	8			
92210	92210-0003	NUT,CAP,6MM	4			
92210A	92210-0130	NUT	3			
132	132BB0618	BOLT-FLANGED-SMALL,6X18	3			

This catalog covers:
'08 ZX1000E8F Chassis

GRID NO. **H-4** This grid covers:
Cowling Lowers

F2872

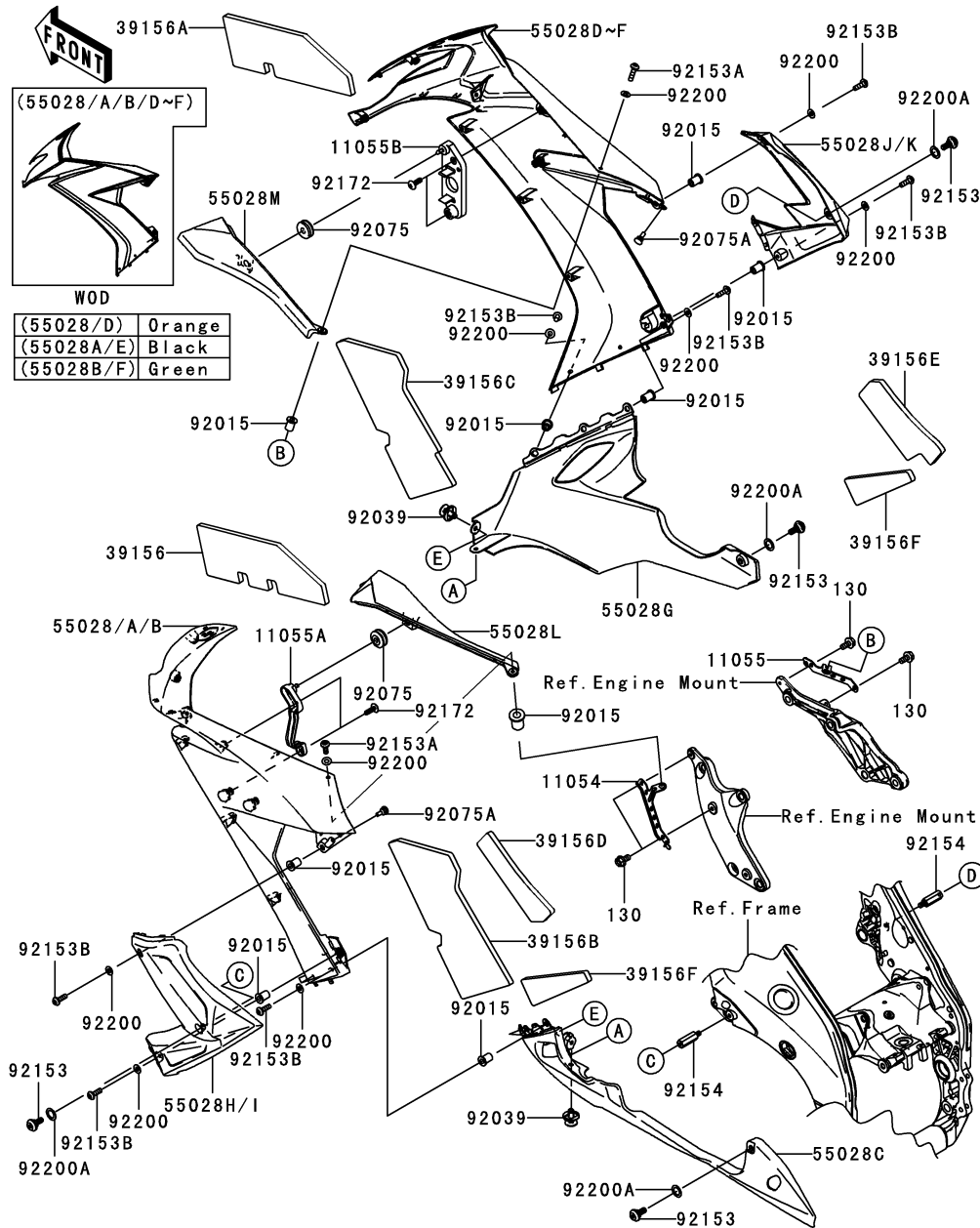

Ref. No.	Part No.	Description	Spec Code	Quantity-ZX1000	
				'08	E8F
11054	11054-1906	BRACKET		1	
11055	11055-0285	BRACKET		1	
11055A	11055-0317	BRACKET,INNER COWLING,LH		1	
11055B	11055-0318	BRACKET,INNER COWLING,RH		1	
39156	39156-0444	PAD,UPP COWLING,LH,UPP		1	
39156A	39156-0445	PAD,UPP COWLING,RH,UPP		1	
39156B	39156-0446	PAD,UPP COWLING,LH,LWR		1	
39156C	39156-0447	PAD,UPP COWLING,RH,LWR		1	
39156D	39156-0448	PAD,CNT COWLING,LH,UPP		1	
39156E	39156-0449	PAD,CNT COWLING,RH,UPP		1	
39156F	39156-0450	PAD,CNT COWLING,LH&RH,RR		2	
55028	55028-0170-17H	COWLING,UPP,LH,P.W.ORANGE		1	
55028A	55028-0170-17K	COWLING,UPP,LH,M.D.BLACK		1	
55028B	55028-0170-777	COWLING,UPP,LH,L.GREEN		1	
55028C	55028-0171-18T	COWLING,LWR,LH,F.S.BLACK		1	
55028D	55028-0172-17H	COWLING,UPP,RH,P.W.ORANGE		1	
55028E	55028-0172-17K	COWLING,UPP,RH,M.D.BLACK		1	
55028F	55028-0172-777	COWLING,UPP,RH,L.GREEN		1	
55028G	55028-0173-18T	COWLING,LWR,RH,F.S.BLACK		1	
55028H	55028-0174-11J	COWLING,CNT,LH,F.S.BLACK		1	
55028I	55028-0174-17K	COWLING,CNT,LH,M.D.BLACK		1	
55028J	55028-0175-11J	COWLING,CNT,RH,F.S.BLACK		1	
55028K	55028-0175-17K	COWLING,CNT,RH,M.D.BLACK		1	
55028L	55028-0204-6Z	COWLING,INNER,LH,F.BLACK		1	
55028M	55028-0205-6Z	COWLING,INNER,RH,F.BLACK		1	
92015	92015-1757	NUT,WELL,5MM		12	
92039	92039-0014	RIVET		2	
92075	92075-1067	DAMPER		2	
92075A	92075-1808	DAMPER		2	
92153	92153-0489	BOLT,SOCKET,6MM		4	
92153A	92153-0873	BOLT,SOCKET,5X20		2	
92153B	92153-1244	BOLT,SOCKET,5X16		10	
92154	92154-0091	BOLT,8MM		2	
92172	92172-0175	SCREW,TAPPING,5X16		4	
92200	92200-0006	WASHER,NYLONE,5.3X11.5X0.5		12	
92200A	92200-0157	WASHER,10.4X15.9X0.5		4	
130	130BB0612	BOLT-FLANGED,6X12		4	

This catalog covers:
'08 ZX1000E8F

GRID NO.

L-13

This grid covers:

Numerical Parts Index

Part No.	Grid No.	Part No.	Grid No.	Part No.	Grid No.	Part No.	Grid No.	Part No.	Grid No.	Part No.	Grid No.
11004-0081	B-3	11065-0225	B-5	130BB0514	C-10	13272-0505	F-12	18110-0098	B-7	26011-0082	G-8
11008-0130	B-3	11065-0282	C-9	130BB0518	B-8	13272-0576	C-4	21003-0072	C-14	26011-0167	G-8
11009-1145	D-7	11065-1247	B-4	130BB0518	D-7	13280-0272	B-5	21007-0117	C-14	26011-0168	G-8
11009-1325	F-11	11065-5001	F-11	130BB0520	F-5	13280-1160	F-9	21007-5056	G-9	26011-0203	D-4
11010-0138	B-5	12004-0035	B-9	130BB0612	H-4	132BB0612	D-7	21025-011	D-4	26012-0036	G-8
11010-0170	B-5	12005-0046	B-9	130BB0614	D-5	132BB0618	H-3	21039-1066	D-4	26031-0574	G-8
11012-1084	D-7	12009-0017	B-9	130BB0616	C-5	132BC0620	C-13	21040-1057	D-4	26031-0580	C-9
11013-0026	B-5	12011-1053	B-9	130BB0616	E-10	132BC0620	D-7	21066-0028	C-14	26031-0674	G-8
11051-1503	G-6	12021-0020	B-4	130BB0622	C-14	132BC0830	B-8	21163-0028	D-4	27002-0006	G-8
11053-0386	F-13	12032-0010	B-9	130BB0670	F-12	132BD0825	C-7	21171-0005	D-3	27002-0007	G-8
11053-1545	F-5	12046-0068	B-11	130BD0610	C-5	14001-0121	C-5	21174-0003	B-7	27003-0052	G-8
11054-0023-18R	F-10	12048-0030	B-11	130CA0616	G-6	14013-1051	C-5	21175-0158	C-12	27005-5145	G-9
11054-0488	B-3	12053-0041	B-11	130CB0618	F-10	14014-0012	C-5	21175-0190	C-12	27008-0029	G-9
11054-1901	E-10	12053-0050	B-11	13102-0018	B-13	14014-0021	C-5	21176-0026	C-12	27008-5047	G-9
11054-1903	F-10	12053-0062	B-11	13107-0060	C-13	14026-0054	C-7	21176-0042	C-5	27008-5048	G-9
11054-1904	G-9	12053-0089	C-7	13107-0192	D-4	14031-0045-11E	C-7	21176-0048	C-12	27010-0025	F-5
11054-1905	H-3	120CA0522	G-6	13107-0193	D-4	14032-0105	C-7	21176-0058	C-12	27010-0064	G-9
11054-1906	H-4	120CA0610	F-13	13107-0194	B-11	14037-0077	B-5	21176-0058	C-9	27010-1313	C-5
11054-1958	C-7	120CA0620	F-9	13127-0060	B-14	14044-0031	C-7	21176-0101	C-12	27010-1450	D-4
11054-1959	C-7	120CA0625	B-11	13128-0019	B-14	14073-0206	B-5	21176-0114	C-12	27010-1486	G-9
11054-1960	C-14	120CB0510	D-4	13140-0027	C-3	14073-0207	B-5	21176-0115	C-12	27010-1492	F-9
11055-0115	G-4	120CB0512	G-9	13140-0028	C-3	14073-0208	B-5	21176-1120	C-12	27012-0115	F-12
11055-0116	G-4	120CB0522	C-12	13144-0004	B-14	14073-0231	B-5	21181-0004	G-9	27012-0115	G-4
11055-0285	H-4	120CB0610	B-8	13145-0039	C-3	14073-0232	B-5	21183-0004	G-9	27016-0003	G-9
11055-0316	G-9	120CB0610	E-10	13151-0044	C-3	14073-0233	B-5	220AB0525	F-9	27016-5310	G-9
11055-0317	H-4	120CD0630	B-3	13159-1056	F-7	14091-0860	C-7	220AB0535	F-9	27045-5388	G-9
11055-0318	H-4	120Q0620	B-13	13159-1061	F-5	14091-0878-839	H-3	220AB0545	F-9	28012-1077	G-9
11055-0319	F-5	13001-0098	B-12	13161-0061	C-4	14091-0905	C-7	221AB0635	G-9	31064-0023	C-9
11055-0756	D-4	13002-0004	B-12	13165-0017	C-4	14091-0909	B-4	224AB0408	G-7	318L0800	E-6
11055-0871	F-13	13008-0005	B-12	13187-0006	B-13	14091-0915	B-7	224AB0412	F-7	32033-1535	C-13
11055-1011	E-5	13031-0108	B-12	13194-3704	D-4	14091-5430	F-14	23007-0101	G-5	32037-0013	E-5
11055-1026	H-3	13042-0029	F-9	13236-0103	F-5	16007-0003	B-9	23007-0102	G-7	32043-0059-18R	E-11
11055-1027	H-3	13070-0045	F-8	13236-0141	C-4	16014-0002	C-9	23007-0103	G-7	32052-0095	F-12
11055-1029	F-7	13078-0012	C-4	13236-0146	F-3	16021-0020	C-9	23007-0111	G-7	32065-0042	E-10
11055-1257	C-9	13087-0010	B-13	13236-0148	C-4	16065-0052	B-3	23007-0112	G-7	32085-0047	E-8
11060-1103	B-7	13087-0011	B-13	13239-0030	C-3	16073-0076	C-10	23008-0090	G-5	32099-0019	D-4
11060-1376	B-7	13088-0003	B-13	13242-0052	C-4	16073-3707	C-9	23016-0020	G-6	32099-0023	C-13
11060-1971	B-7	13088-0013	B-13	13251-0023-II	B-12	16085-0102	D-4	23025-0027	G-6	32099-1193	F-9
11061-0064	B-4	13089-0008	B-13	13262-0350	B-14	16097-0004	C-13	23026-0014	G-6	32160-0254-18R	E-3
11061-0177	C-7	13089-0009	B-13	13262-0615	B-14	16115-1009	C-7	23037-0145	G-7	32160-0255-18R	E-3
11061-0178	C-7	13089-1093	B-13	13262-0616	B-14	16126-0038	B-5	23037-0146	G-7	32160-0347	E-3
11061-0179	C-7	13091-1624	F-9	13262-0618	B-14	16126-1140	E-12	23040-0075	G-7	32190-0118	E-4
11061-0180	C-8	13091-1840	B-13	13262-0619	B-14	16130-1059	C-13	23040-0076	G-7	32190-0196	E-4
11061-0223	B-4	13095-0080	B-13	13262-0620	B-14	16142-0005	C-13	236C0410	F-9	32190-0328-18R	E-4
11061-0262	C-7	130AA0510	G-9	13262-0621	B-14	16146-0074-839	G-4	25009-004	G-6	33001-0130-18R	E-6
11061-0309	B-5	130AA0614	B-6	13262-0622	B-14	16154-0057	C-13	25023-5001	F-14	33032-0013	E-6
11061-0315	B-5	130BA0610	D-4	13262-0623	B-14	16163-0115	C-9	25031-0201	F-14	33040-0016	E-6
11061-0316	B-5	130BA0610	F-12	13262-0665	B-14	16181-0014	B-5	26006-0001	G-8	33040-1109	E-6
11061-0329	G-6	130BA0610	G-8	13271-0148	C-5	18091-0549	B-7	26006-1078	G-8	34024-0047-18R	E-11
11061-0336	C-7	130BA0616	F-13	13271-0594	C-5	180BA0614	F-3	26011-0036	G-8	34028-0092	E-8

This catalog covers:
'08 ZX1000E8F

GRID NO.

L-14

This grid covers:

Numerical Parts Index

Part No.	Grid No.	Part No.	Grid No.	Part No.	Grid No.	Part No.	Grid No.	Part No.	Grid No.	Part No.	Grid No.
34028-0093	E-8	39156-0446	H-4	43048-1100	F-6	482L5000	E-8	55020-0447	G-9	56054-0172	G-14
34028-0094	E-8	39156-0447	H-4	43049-0012	F-6	49002-0009	B-3	55020-0467	B-7	56054-0238	E-3
34028-0095	E-8	39156-0448	H-4	43049-0013	F-6	49006-1054	F-8	55020-0468	B-7	56054-0239	E-3
35004-0093-17H	E-9	39156-0449	H-4	43049-1004	F-6	49006-1095	F-8	55020-0488	B-7	56070-1143	G-11
35004-0093-17K	E-9	39156-0450	H-4	43049-1068	F-6	49006-1212	F-8	55028-0170-17H	H-4	59026-0031	D-3
35019-0060	E-10	39156-0451	F-12	43049-1097	F-8	49016-0023	G-5	55028-0170-17K	H-4	59051-0080	C-13
35023-0117-839	E-10	39156-0454	D-5	43049-1107	F-6	49016-0054	D-5	55028-0170-777	H-4	59051-0088	D-4
35023-0118-839	E-10	39156-0462	D-7	43056-1054	F-6	49016-1147	F-5	55028-0171-18T	H-4	59071-0062	C-10
35063-0226-11E	E-5	39162-0006	B-5	43056-1054	F-8	49033-0011	C-9	55028-0172-17H	H-4	59071-3752	C-9
35063-0227-11E	E-5	39178-0087	B-7	43056-1056	F-5	49033-0017	C-10	55028-0172-17K	H-4	59091-0007	B-7
35063-0444-11E	E-5	39192-0089	D-7	43057-003	F-6	49034-0020	C-8	55028-0172-777	H-4	59478-0006	C-10
35063-0445-11E	E-5	41009-0186	E-12	43057-003	F-8	49040-0030	C-11	55028-0173-18T	H-4	59502-0033	D-5
35063-0447	B-5	41009-0187	E-12	43057-1001	F-5	49044-0008	D-7	55028-0174-11J	H-4	600A0500	B-14
35063-0448	D-5	41046-0012	C-7	43059-1696	F-5	49047-0021	C-3	55028-0174-17K	H-4	600A0800	E-8
36001-0126-11J	G-4	41068-0040	E-14	43064-006	F-7	49047-0022	C-3	55028-0175-11J	H-4	601B6005UU	E-13
36001-0126-17K	G-4	41068-0049	E-13	43078-0040	F-7	49054-1067	D-7	55028-0175-17K	H-4	601B6204UU	E-14
36001-0127-11J	G-4	41073-0081-18F	E-14	43078-0050	D-7	49056-0024	C-9	55028-0204-6Z	H-4	601B6205UU	E-14
36001-0127-17K	G-4	41073-0081-19K	E-14	43078-1099	F-5	49056-0025	C-10	55028-0205-6Z	H-4	610A0406	C-3
36014-0038	G-4	41073-0084-18F	E-13	43080-0014-DJ	F-8	49062-0040	B-7	55028-0228-11J	H-3	610A0408	C-13
36040-0073-17H	G-4	41073-0084-19K	E-13	43080-0065-DJ	F-6	49065-0013	C-13	55028-0228-17K	H-3	670D1509	B-11
36040-0073-17K	G-4	41075-0007	E-12	43080-0066-DJ	F-6	49078-0022	B-9	55028-0264-839	H-3	670E5075	C-11
36040-0073-777	G-4	41075-0008	E-12	43082-0004	F-8	49078-0066	B-9	550AA2015	F-7	671B2560	E-14
36040-0074-17H	G-4	41075-0009	E-12	43082-0091	F-6	49085-1066	D-5	550D4035	E-14	671B2565	D-6
36040-0074-17K	G-4	41080-0040	F-8	43084-003	F-8	49091-0001	F-5	550S3025	E-5	671E2565	B-6
36040-0074-777	G-4	41080-0159-5C	F-6	43095-0348	F-5	49091-0001	F-7	551A0812	C-7	702A06750	F-12
36040-0075-17H	G-4	410AA0800	F-10	43095-0350	F-7	49118-0116	B-11	555A0316	D-4	92002-1323	F-5
36040-0075-17K	G-4	42033-0028	E-14	43095-0380	F-7	49118-0117	B-11	56001-0102	H-3	92004-0028	E-14
36040-0075-777	G-4	42036-1251	E-14	44008-0041-828	F-11	51044-0046	C-10	56001-0103	H-3	92004-1186	B-3
39007-0006	E-7	42036-1258	E-7	44013-0105-18R	F-11	51044-0047	C-11	56007-0051	G-10	92005-0010	D-7
39045-0035	B-5	42036-1341	E-6	44013-0106-18R	F-11	51049-0014	F-12	56008-1075	G-10	92005-0056	D-7
39061-0121	D-5	42036-1342	E-7	44023-0064	F-11	51085-5409-17H	F-12	56019-120	G-10	92005-0076	D-7
39062-0100	D-7	42036-1360	E-7	44026-0117	F-11	51085-5409-777	F-12	56030-0185	G-8	92005-0102	D-7
39062-0170	D-7	42041-0055	E-14	44037-0079	F-11	51085-5411-17K	F-12	56030-0186	G-8	92005-1238	C-5
39062-0228	D-7	42045-018	E-14	44039-0069-499	F-11	52005-1120	C-5	56030-1211	G-11	92009-1158	G-7
39062-0230	D-6	43010-1062	F-7	44071-0412	F-10	53003-0120-MA	F-13	56031-1441	G-11	92009-1164	F-14
39062-0236	D-6	43015-0097	F-5	44071-5076	F-11	53003-0121-MA	F-13	56033-0232	G-11	92009-1197	F-14
39062-0237	D-7	43015-0103	F-7	44071-5077	F-11	53065-0016-17H	F-13	56033-0234	G-11	92009-1360	C-5
39062-0256	D-7	43020-0010	F-5	45014-0189-23H	F-4	53065-0016-17K	F-13	56053-0270	G-11	92009-1481	B-7
39062-0260	D-7	43020-1094	F-7	46003-0144	F-9	53065-0016-777	F-13	56054-0161	G-9	92009-1499	B-5
39062-0267	D-7	43026-0009	F-7	46003-0145	F-9	53066-0188-MA	F-13	56054-0164	G-12	92009-1570	F-5
39067-0009	D-6	43026-1051	F-5	46019-0020	F-9	53066-0189-12Y	F-13	56054-0164	G-14	92009-1605	G-6
39076-0014	D-4	43027-1051	F-5	46075-0068	F-9	54010-0074	G-3	56054-0165	G-12	92009-1895	C-3
39111-0054	C-4	43027-1053	F-7	46076-0033	F-9	54010-0105	B-7	56054-0165	G-14	92009-1984	C-12
39111-0057	E-7	43028-1057	F-5	46091-0114	F-9	54010-0106	B-7	56054-0166	G-12	92015-1188	E-11
39130-1078	B-13	43028-1065	F-7	46091-0115	F-9	54011-0080	G-3	56054-0167	G-12	92015-1233	F-5
39130-1079	B-13	43034-0037	F-8	46092-0006	F-9	54012-0221	G-3	56054-0167	G-14	92015-1311	B-12
39154-0030	H-3	43034-1016	F-5	46102-0047	B-13	55020-0384	E-6	56054-0168	G-13	92015-1386	G-4
39156-0443	E-5	43044-0002	F-8	461K0500	D-4	55020-0411	G-9	56054-0169	G-13	92015-1402	B-7
39156-0444	H-4	43048-0003	F-8	480J1400	C-4	55020-0414	E-5	56054-0170	G-13	92015-1476	D-4
39156-0445	H-4	43048-0013	F-6	482L0100	E-8	55020-0415	E-5	56054-0171	G-13	92015-1487	D-5

This catalog covers:
'08 ZX1000E8F

GRID NO.

L-15

This grid covers:

Numerical Parts Index

Part No.	Grid No.	Part No.	Grid No.	Part No.	Grid No.	Part No.	Grid No.	Part No.	Grid No.	Part No.	Grid No.
92015-1757	B-5	92043-0028	E-8	92055-0145	F-11	92075-1634	D-7	92144-1854	B-13	92152-0105	E-14
92015-1757	G-4	92043-0062	B-11	92055-0156	B-5	92075-1808	F-13	92145-0055	C-9	92152-0134	C-12
92015-1757	G-6	92043-0104	F-7	92055-0170	C-10	92075-1808	H-4	92145-0220	B-13	92152-0153	B-14
92015-1757	H-3	92043-1264	B-3	92055-049	C-7	92075-1912	C-12	92145-0230	F-3	92152-0154	E-6
92015-1757	H-4	92043-1489	F-8	92055-091	C-3	92075-1927	F-13	92145-0325	B-13	92152-0188	B-7
92015-1795	F-11	92043-1506	C-5	92055-1141	C-7	92075-1983	F-12	92145-0580	F-6	92152-0206	E-14
92015-1881	E-5	92043-1595	E-8	92055-1251	F-5	92092-0003	F-4	92145-0603	E-8	92152-0237	B-7
92015-1963	B-14	92043-1654	C-3	92055-1251	F-7	92093-0058	F-11	92145-0629	C-4	92152-0240	E-13
92022-1132	D-4	92043-1676	C-4	92055-1276	D-4	92093-0098	B-5	92145-0631	C-4	92152-0242	E-13
92022-1299	F-11	92043-1690	C-5	92055-1352	B-4	92093-0108	B-5	92145-1286	F-9	92152-0286	B-7
92022-1405	F-14	92043-1709	F-6	92055-1370	D-4	92093-0109	B-5	92145-1319	E-8	92152-0289	E-13
92022-1601	F-7	92043-4009	B-4	92055-1408	C-7	92093-0110	B-5	92145-1414	C-3	92152-0352	G-9
92022-1827	C-4	92045-0003	B-14	92055-1503	C-13	92093-0111	B-5	92145-1490	C-4	92152-0363	E-6
92022-183	G-4	92045-0014	B-14	92055-1550	D-4	92104-0002	G-10	92150-1090	F-9	92152-0413	B-11
92022-304	C-5	92045-0017	E-6	92055-1551	D-4	92104-0004	G-10	92150-1162	C-6	92152-0617	G-6
92022-311	C-13	92045-0048	B-14	92055-1600	B-3	92104-1062	G-10	92150-1186	D-5	92152-0647	E-4
92022-3730	B-7	92045-1045	C-3	92055-1622	C-9	92104-1064	G-10	92150-1251	C-6	92152-0660	E-4
92026-0037	B-13	92045-1053	B-13	92055-1699	D-7	92106-1001	G-10	92150-1433	C-14	92152-0679	F-6
92026-0057	E-5	92045-1152	C-3	92057-0085	B-11	92107-005	G-10	92150-1673	C-4	92152-0718	C-14
92026-0119	B-13	92045-1384	E-3	92057-0140	E-14	92107-1051	G-10	92150-1717	C-14	92152-0720	C-4
92026-0125	F-11	92046-0004	D-4	92058-0015	E-14	92110-1015	G-10	92150-1771	F-6	92152-1074	D-5
92026-0129	E-5	92046-0008	E-6	92062-0004	C-5	92110-1132	G-10	92150-1771	F-8	92152-1074	G-9
92027-1018	F-10	92046-037	C-5	92065-097	C-12	92110-1147	G-10	92150-1779	B-11	92152-1182	F-12
92033-0034	F-5	92046-1010	C-7	92065-097	C-8	92110-1152	G-10	92150-1845	E-5	92152-1414	C-4
92033-025	B-14	92046-1263	B-13	92066-0003	C-5	92110-1153	G-10	92150-1969	D-4	92153-0360	F-6
92033-1037	B-14	92046-1272	E-7	92066-0016	B-3	92110-3703	G-10	92151-1118	D-3	92153-0393	F-7
92033-1041	E-6	92046-1273	E-7	92066-0016	C-5	92111-1051	G-10	92151-1219	G-4	92153-0410	F-12
92033-1043	E-14	92046-1291	B-14	92066-0067	C-7	92112-1001	G-10	92151-1223	C-6	92153-0410	F-5
92033-1054	B-12	92048-1053	B-14	92066-0071	E-3	92126-004	G-10	92151-1225	D-5	92153-0421	C-4
92033-1077	F-11	92049-0022	E-3	92066-0120	E-5	92127-003	G-10	92151-1226	C-4	92153-0422	E-10
92033-1186	F-5	92049-0050	E-13	92066-1012	C-5	92139-0032	B-12	92151-1241	G-5	92153-0422	E-6
92033-1186	F-7	92049-0072	F-11	92066-1110	C-5	92139-0033	B-12	92151-1289	F-8	92153-0438	E-4
92033-1249	B-14	92049-1056	E-14	92066-1174	C-8	92139-0034	B-12	92151-1389	C-5	92153-0439	E-4
92033-1305	C-5	92049-1223	E-7	92066-1211	B-5	92139-0036	B-14	92151-1521	C-6	92153-0446	C-4
92033-3731	D-4	92049-1225	E-7	92069-0007	G-5	92139-0037	B-14	92151-1523	F-9	92153-0447	C-6
92037-010	F-12	92049-1287	E-14	92069-0014	G-5	92139-0038	B-14	92151-1532	B-7	92153-0448	C-6
92037-147	B-5	92049-1314	E-6	92069-0020	G-7	92139-0066	B-14	92151-1654	E-5	92153-0454	B-3
92037-147	D-7	92049-1349	B-9	92069-1016	G-5	92139-0067	B-13	92151-1654	E-9	92153-0474	E-3
92037-1827	F-5	92049-1352	E-6	92069-1016	G-6	92139-0122	B-12	92151-1654	G-4	92153-0488	E-4
92039-0014	H-4	92049-1382	E-3	92070-0014	D-3	92139-0123	B-12	92151-1797	E-11	92153-0489	F-13
92039-0051	G-4	92049-1474	C-5	92071-1043	C-7	92139-0124	B-12	92151-1802	E-11	92153-0489	H-4
92039-0067	F-7	92049-1475	C-7	92071-1137	B-5	92139-0217	B-12	92151-1930	D-4	92153-0508	E-7
92039-0068	E-10	92049-1493	E-7	92072-0012	C-9	92072-0012	B-12	92151-1930	D-7	92153-0548	F-11
92039-0068	G-4	92049-1520	C-5	92072-1176	E-5	92139-0219	B-12	92151-1946	G-9	92153-0564	D-6
92039-0068	H-3	92055-0018	C-13	92072-1306	E-5	92143-1353	G-5	92152-0017	F-5	92153-0627	F-5
92039-1234	H-3	92055-0021	D-7	92072-1414	G-8	92143-1962	B-5	92152-0076	E-4	92153-0627	F-7
92042-007	B-3	92055-0053	B-11	92075-1067	H-4	92143-1962	D-7	92152-0088	E-14	92153-0640	D-7
92042-007	C-7	92055-0064	C-10	92075-1123	D-5	92144-1139	G-9	92152-0091	F-12	92153-0656	B-3
92042-030	C-13	92055-0069	D-7	92075-1123	F-12	92144-1719	F-8	92152-0092	G-6	92153-0661	C-13
92042-044	C-7	92055-0088	D-7	92075-161	F-5	92144-1818	E-11	92152-0103	F-9	92153-0690	C-7

This catalog covers:
'08 ZX1000E8F

GRID NO.
L-16

This grid covers:
Numerical Parts Index

Part No.	Grid No.	Part No.	Grid No.	Part No.	Grid No.	Part No.	Grid No.	Part No.	Grid No.	Part No.	Grid No.
92153-0702	B-7	92153-1735	C-3	92170-1900	G-8	92180-0116	B-9	92200-0051	B-14	92210-1101	C-4
92153-0713	E-4	92153-1884	F-11	92170-1925	G-8	92180-0117	B-9	92200-0078	B-7	92210-1150	E-7
92153-0736	E-6	92153-1890	F-6	92170-3729	D-6	92180-0118	B-9	92200-0081	E-3	92210-1365	E-4
92153-0764	C-7	92153-1933	E-3	92171-0179	D-7	92180-0119	B-9	92200-0114	B-3	99996-1358-17H	F-13
92153-0797	B-13	92153-1938	E-8	92171-0180	D-7	92180-0120	B-9	92200-0115	C-6	99996-1358-17K	F-13
92153-0809	B-12	92153-1948	B-7	92171-0292	B-7	92180-0121	B-9	92200-0138	B-14	99996-1358-777	F-13
92153-0815	E-4	92154-0026	H-3	92171-0305	G-8	92180-0122	B-9	92200-0157	H-4	99999-0148	C-9
92153-0816	B-7	92154-0031	G-9	92171-0316	G-8	92180-0123	B-9	92200-0164	G-7		
92153-0817	B-7	92154-0040	C-7	92171-0359	C-9	92180-0124	B-9	92200-0165	G-7		
92153-0817	F-7	92154-0062	B-11	92171-0391	B-6	92180-0125	B-9	92200-0174	C-4		
92153-0868	F-5	92154-0077	E-3	92171-0652	B-7	92180-0126	B-9	92200-0212	G-9		
92153-0873	H-4	92154-0080	B-7	92171-0652	D-7	92180-0127	B-9	92200-0238	D-4		
92153-0875	B-5	92154-0091	H-4	92171-0652	G-8	92180-0128	B-9	92200-0265	C-4		
92153-0893	B-3	92154-0093	C-7	92171-0675	G-3	92180-0129	B-9	92200-0279	F-3		
92153-0907	F-9	92154-0105	B-6	92171-0703	C-8	92180-0130	B-9	92200-0280	F-3		
92153-1010	C-7	92160-1167	F-14	92171-0719	D-7	92180-0131	B-9	92200-0281	E-3		
92153-1016	B-4	92160-1167	G-5	92171-0723	D-6	92180-0132	B-9	92200-0284	G-6		
92153-1086	C-13	92160-1613	G-4	92171-0776	F-7	92180-0133	B-9	92200-0293	F-10		
92153-1127	E-4	92161-0041	C-12	92171-0779	E-10	92180-0134	B-9	92200-0369	C-14		
92153-1228	F-11	92161-0041	C-9	92171-0779	G-8	92180-0135	B-9	92200-0420	F-11		
92153-1244	B-5	92161-0056	C-14	92171-1539	B-6	92180-0136	B-9	92200-0424	B-12		
92153-1244	G-4	92161-0070	C-13	92171-1566	C-7	92180-0137	B-9	92200-0443	F-11		
92153-1244	G-7	92161-0117	G-9	92171-1610	B-3	92180-0138	B-9	92200-1065	B-14		
92153-1244	H-3	92161-0118	G-9	92171-1668	B-7	92180-0139	B-10	92200-1260	B-13		
92153-1244	H-4	92161-0135	B-7	92171-1698	F-7	92180-0140	B-10	92200-1388	E-9		
92153-1267	F-5	92161-0149	F-13	92171-1699	F-7	92180-0141	B-10	92200-1487	B-13		
92153-1283	C-11	92161-0154	B-6	92171-1871	B-7	92180-0142	B-10	92200-1489	E-14		
92153-1284	B-4	92161-0191	G-6	92171-1875	B-7	92180-0143	B-10	92210-0003	G-9		
92153-1315	C-7	92161-0204	B-7	92172-0056	B-6	92180-0144	B-10	92210-0003	H-3		
92153-1318	E-4	92161-0240	G-9	92172-0064	C-10	92180-0145	B-10	92210-0006	F-9		
92153-1319	E-4	92161-0257	G-9	92172-0064	C-9	92180-0146	B-10	92210-0007	C-12		
92153-1328	E-4	92161-0301	G-4	92172-0065	C-9	92180-0147	B-10	92210-0007	F-5		
92153-1356	B-5	92161-0308	B-7	92172-0175	H-3	92180-0148	B-10	92210-0007	G-6		
92153-1356	G-4	92161-0317	G-6	92172-0175	H-4	92190-1185	F-3	92210-0007	G-9		
92153-1446	E-10	92161-0342	E-14	92172-0183	F-9	92191-0020	C-9	92210-0095	E-3		
92153-1518	F-5	92161-0518	F-12	92172-0188	G-9	92191-1001	E-11	92210-0096	E-3		
92153-1521	D-4	92161-0529	C-12	92172-0269	F-10	92192-0018	C-9	92210-0099	E-6		
92153-1545	E-7	92161-0627	F-13	92172-0337	B-6	92192-0033	B-6	92210-0121	B-7		
92153-1546	E-7	92161-0629	F-13	92172-0384	C-5	92192-0106	C-9	92210-0130	G-5		
92153-1547	E-7	92161-0658	B-7	92172-0393	C-9	92192-0156	B-6	92210-0130	H-3		
92153-1569	C-8	92161-0674	G-7	92172-1060	F-9	92192-0237	B-6	92210-0134	E-6		
92153-1570	C-6	92161-1177	G-4	92172-1061	G-9	92192-0527	B-6	92210-0152	B-13		
92153-1584	C-12	92161-1228	B-7	92180-0108	B-9	92192-0739	C-9	92210-0188	D-4		
92153-1616	F-12	92161-1300	C-4	92180-0109	B-9	92192-0740	C-9	92210-0276	E-14		
92153-1627	F-12	92161-1313	G-6	92180-0110	B-9	92192-0741	C-9	92210-0277	F-13		
92153-1630	E-5	92161-1330	F-12	92180-0111	B-9	92200-0006	H-3	92210-0320	E-6		
92153-1642	F-11	92170-1090	F-5	92180-0112	B-9	92200-0006	H-4	92210-0321	E-4		
92153-1669	C-4	92170-1091	F-5	92180-0113	B-9	92200-0043	E-8	92210-0321	E-7		
92153-1675	E-10	92170-1091	F-7	92180-0114	B-9	92200-0047	C-6	92210-0481	B-7		
92153-1675	G-4	92170-1493	D-7	92180-0115	B-9	92200-0050	B-14	92210-1100	C-4		

This catalog covers:

'08 ZX1000E8F

GRID NO.

B-16

This grid covers:

Part Name Index

Air Cleaner.....	B-5/B-6
Brake Pedal.....	F-3
Cables.....	G-3
Camshaft(s).....	B-11
Chain Cover.....	G-4
Chassis Electrical Equipment.....	G-8
Clutch.....	B-13
Cowling.....	H-3
Cowling Lowers.....	H-4
Crankcase.....	C-5
Crankcase Bolt Pattern.....	C-6
Crankshaft.....	B-12
Cylinder Head.....	B-3
Cylinder Head Cover.....	B-4
Decals(Black).....	G-13
Decals(Green).....	G-12
Decals(Orange).....	G-14
Engine Cover(s).....	C-7
Engine Mount.....	E-4
Footrests.....	E-8
Frame.....	E-3
Frame Fittings.....	E-5
Front Brake.....	F-6
Front Fender(s).....	E-9
Front Fork.....	F-11
Front Hub.....	E-13
Front Master Cylinder.....	F-5
Fuel Injection.....	C-12
Fuel Pump.....	C-11
Fuel Tank.....	F-12
Gear Change Drum.....	C-3
Gear Change Mechanism.....	C-4
Generator.....	C-14
Handlebar.....	F-9

Headlight(s).....	G-5
Ignition Switch.....	G-9
Ignition System.....	D-3
Labels.....	G-11
Meter(s).....	F-14
Muffler(s).....	B-7/B-8
Oil Cooler.....	D-6
Oil Pan.....	C-8
Oil Pump.....	C-13
Owner's Tools.....	G-10
Piston(s).....	B-12
Radiator.....	D-5
Rear Brake.....	F-8
Rear Fender(s).....	E-10
Rear Hub.....	E-14
Rear Master Cylinder.....	F-7
Seat.....	F-13
Shift Fork(s).....	C-3
Shock Absorber(s).....	F-4
Side Covers.....	G-4
Stand(s).....	E-11
Starter Motor.....	D-4
Steering Damper.....	F-10
Suspension.....	E-7
Swingarm.....	E-6
Taillight(s).....	G-6
Tensioner.....	B-11
Throttle.....	C-9
Tires.....	E-12
Top Feed Injector.....	C-10
Transmission.....	B-14
Turn Signals.....	G-7
Valve(s).....	B-10/B-9
Water Pipe.....	D-7

This catalog covers:

'08 ZX1000E8F

GRID NO.

C-16

This grid covers:

Part Name Index

Air Cleaner.....	B-5/B-6
Brake Pedal.....	F-3
Cables.....	G-3
Camshaft(s).....	B-11
Chain Cover.....	G-4
Chassis Electrical Equipment.....	G-8
Clutch.....	B-13
Cowling.....	H-3
Cowling Lowers.....	H-4
Crankcase.....	C-5
Crankcase Bolt Pattern.....	C-6
Crankshaft.....	B-12
Cylinder Head.....	B-3
Cylinder Head Cover.....	B-4
Decals(Black).....	G-13
Decals(Green).....	G-12
Decals(Orange).....	G-14
Engine Cover(s).....	C-7
Engine Mount.....	E-4
Footrests.....	E-8
Frame.....	E-3
Frame Fittings.....	E-5
Front Brake.....	F-6
Front Fender(s).....	E-9
Front Fork.....	F-11
Front Hub.....	E-13
Front Master Cylinder.....	F-5
Fuel Injection.....	C-12
Fuel Pump.....	C-11
Fuel Tank.....	F-12
Gear Change Drum.....	C-3
Gear Change Mechanism.....	C-4
Generator.....	C-14
Handlebar.....	F-9

Headlight(s).....	G-5
Ignition Switch.....	G-9
Ignition System.....	D-3
Labels.....	G-11
Meter(s).....	F-14
Muffler(s).....	B-7/B-8
Oil Cooler.....	D-6
Oil Pan.....	C-8
Oil Pump.....	C-13
Owner's Tools.....	G-10
Piston(s).....	B-12
Radiator.....	D-5
Rear Brake.....	F-8
Rear Fender(s).....	E-10
Rear Hub.....	E-14
Rear Master Cylinder.....	F-7
Seat.....	F-13
Shift Fork(s).....	C-3
Shock Absorber(s).....	F-4
Side Covers.....	G-4
Stand(s).....	E-11
Starter Motor.....	D-4
Steering Damper.....	F-10
Suspension.....	E-7
Swingarm.....	E-6
Taillight(s).....	G-6
Tensioner.....	B-11
Throttle.....	C-9
Tires.....	E-12
Top Feed Injector.....	C-10
Transmission.....	B-14
Turn Signals.....	G-7
Valve(s).....	B-10/B-9
Water Pipe.....	D-7

This catalog covers:

'08 ZX1000E8F

GRID NO.

D-16

This grid covers:

Part Name Index

Air Cleaner.....	B-5/B-6
Brake Pedal.....	F-3
Cables.....	G-3
Camshaft(s).....	B-11
Chain Cover.....	G-4
Chassis Electrical Equipment.....	G-8
Clutch.....	B-13
Cowling.....	H-3
Cowling Lowers.....	H-4
Crankcase.....	C-5
Crankcase Bolt Pattern.....	C-6
Crankshaft.....	B-12
Cylinder Head.....	B-3
Cylinder Head Cover.....	B-4
Decals(Black).....	G-13
Decals(Green).....	G-12
Decals(Orange).....	G-14
Engine Cover(s).....	C-7
Engine Mount.....	E-4
Footrests.....	E-8
Frame.....	E-3
Frame Fittings.....	E-5
Front Brake.....	F-6
Front Fender(s).....	E-9
Front Fork.....	F-11
Front Hub.....	E-13
Front Master Cylinder.....	F-5
Fuel Injection.....	C-12
Fuel Pump.....	C-11
Fuel Tank.....	F-12
Gear Change Drum.....	C-3
Gear Change Mechanism.....	C-4
Generator.....	C-14
Handlebar.....	F-9

Headlight(s).....	G-5
Ignition Switch.....	G-9
Ignition System.....	D-3
Labels.....	G-11
Meter(s).....	F-14
Muffler(s).....	B-7/B-8
Oil Cooler.....	D-6
Oil Pan.....	C-8
Oil Pump.....	C-13
Owner's Tools.....	G-10
Piston(s).....	B-12
Radiator.....	D-5
Rear Brake.....	F-8
Rear Fender(s).....	E-10
Rear Hub.....	E-14
Rear Master Cylinder.....	F-7
Seat.....	F-13
Shift Fork(s).....	C-3
Shock Absorber(s).....	F-4
Side Covers.....	G-4
Stand(s).....	E-11
Starter Motor.....	D-4
Steering Damper.....	F-10
Suspension.....	E-7
Swingarm.....	E-6
Taillight(s).....	G-6
Tensioner.....	B-11
Throttle.....	C-9
Tires.....	E-12
Top Feed Injector.....	C-10
Transmission.....	B-14
Turn Signals.....	G-7
Valve(s).....	B-10/B-9
Water Pipe.....	D-7

This catalog covers:

'08 ZX1000E8F

GRID NO.

E-16

This grid covers:

Part Name Index

Air Cleaner.....	B-5/B-6
Brake Pedal.....	F-3
Cables.....	G-3
Camshaft(s).....	B-11
Chain Cover.....	G-4
Chassis Electrical Equipment.....	G-8
Clutch.....	B-13
Cowling.....	H-3
Cowling Lowers.....	H-4
Crankcase.....	C-5
Crankcase Bolt Pattern.....	C-6
Crankshaft.....	B-12
Cylinder Head.....	B-3
Cylinder Head Cover.....	B-4
Decals(Black).....	G-13
Decals(Green).....	G-12
Decals(Orange).....	G-14
Engine Cover(s).....	C-7
Engine Mount.....	E-4
Footrests.....	E-8
Frame.....	E-3
Frame Fittings.....	E-5
Front Brake.....	F-6
Front Fender(s).....	E-9
Front Fork.....	F-11
Front Hub.....	E-13
Front Master Cylinder.....	F-5
Fuel Injection.....	C-12
Fuel Pump.....	C-11
Fuel Tank.....	F-12
Gear Change Drum.....	C-3
Gear Change Mechanism.....	C-4
Generator.....	C-14
Handlebar.....	F-9

Headlight(s).....	G-5
Ignition Switch.....	G-9
Ignition System.....	D-3
Labels.....	G-11
Meter(s).....	F-14
Muffler(s).....	B-7/B-8
Oil Cooler.....	D-6
Oil Pan.....	C-8
Oil Pump.....	C-13
Owner's Tools.....	G-10
Piston(s).....	B-12
Radiator.....	D-5
Rear Brake.....	F-8
Rear Fender(s).....	E-10
Rear Hub.....	E-14
Rear Master Cylinder.....	F-7
Seat.....	F-13
Shift Fork(s).....	C-3
Shock Absorber(s).....	F-4
Side Covers.....	G-4
Stand(s).....	E-11
Starter Motor.....	D-4
Steering Damper.....	F-10
Suspension.....	E-7
Swingarm.....	E-6
Taillight(s).....	G-6
Tensioner.....	B-11
Throttle.....	C-9
Tires.....	E-12
Top Feed Injector.....	C-10
Transmission.....	B-14
Turn Signals.....	G-7
Valve(s).....	B-10/B-9
Water Pipe.....	D-7

This catalog covers:

'08 ZX1000E8F

GRID NO.

F-16

This grid covers:

Part Name Index

Air Cleaner.....	B-5/B-6
Brake Pedal.....	F-3
Cables.....	G-3
Camshaft(s).....	B-11
Chain Cover.....	G-4
Chassis Electrical Equipment.....	G-8
Clutch.....	B-13
Cowling.....	H-3
Cowling Lowers.....	H-4
Crankcase.....	C-5
Crankcase Bolt Pattern.....	C-6
Crankshaft.....	B-12
Cylinder Head.....	B-3
Cylinder Head Cover.....	B-4
Decals(Black).....	G-13
Decals(Green).....	G-12
Decals(Orange).....	G-14
Engine Cover(s).....	C-7
Engine Mount.....	E-4
Footrests.....	E-8
Frame.....	E-3
Frame Fittings.....	E-5
Front Brake.....	F-6
Front Fender(s).....	E-9
Front Fork.....	F-11
Front Hub.....	E-13
Front Master Cylinder.....	F-5
Fuel Injection.....	C-12
Fuel Pump.....	C-11
Fuel Tank.....	F-12
Gear Change Drum.....	C-3
Gear Change Mechanism.....	C-4
Generator.....	C-14
Handlebar.....	F-9

Headlight(s).....	G-5
Ignition Switch.....	G-9
Ignition System.....	D-3
Labels.....	G-11
Meter(s).....	F-14
Muffler(s).....	B-7/B-8
Oil Cooler.....	D-6
Oil Pan.....	C-8
Oil Pump.....	C-13
Owner's Tools.....	G-10
Piston(s).....	B-12
Radiator.....	D-5
Rear Brake.....	F-8
Rear Fender(s).....	E-10
Rear Hub.....	E-14
Rear Master Cylinder.....	F-7
Seat.....	F-13
Shift Fork(s).....	C-3
Shock Absorber(s).....	F-4
Side Covers.....	G-4
Stand(s).....	E-11
Starter Motor.....	D-4
Steering Damper.....	F-10
Suspension.....	E-7
Swingarm.....	E-6
Taillight(s).....	G-6
Tensioner.....	B-11
Throttle.....	C-9
Tires.....	E-12
Top Feed Injector.....	C-10
Transmission.....	B-14
Turn Signals.....	G-7
Valve(s).....	B-10/B-9
Water Pipe.....	D-7

This catalog covers:

'08 ZX1000E8F

GRID NO.

G-16

This grid covers:

Part Name Index

Air Cleaner.....	B-5/B-6
Brake Pedal.....	F-3
Cables.....	G-3
Camshaft(s).....	B-11
Chain Cover.....	G-4
Chassis Electrical Equipment.....	G-8
Clutch.....	B-13
Cowling.....	H-3
Cowling Lowers.....	H-4
Crankcase.....	C-5
Crankcase Bolt Pattern.....	C-6
Crankshaft.....	B-12
Cylinder Head.....	B-3
Cylinder Head Cover.....	B-4
Decals(Black).....	G-13
Decals(Green).....	G-12
Decals(Orange).....	G-14
Engine Cover(s).....	C-7
Engine Mount.....	E-4
Footrests.....	E-8
Frame.....	E-3
Frame Fittings.....	E-5
Front Brake.....	F-6
Front Fender(s).....	E-9
Front Fork.....	F-11
Front Hub.....	E-13
Front Master Cylinder.....	F-5
Fuel Injection.....	C-12
Fuel Pump.....	C-11
Fuel Tank.....	F-12
Gear Change Drum.....	C-3
Gear Change Mechanism.....	C-4
Generator.....	C-14
Handlebar.....	F-9

Headlight(s).....	G-5
Ignition Switch.....	G-9
Ignition System.....	D-3
Labels.....	G-11
Meter(s).....	F-14
Muffler(s).....	B-7/B-8
Oil Cooler.....	D-6
Oil Pan.....	C-8
Oil Pump.....	C-13
Owner's Tools.....	G-10
Piston(s).....	B-12
Radiator.....	D-5
Rear Brake.....	F-8
Rear Fender(s).....	E-10
Rear Hub.....	E-14
Rear Master Cylinder.....	F-7
Seat.....	F-13
Shift Fork(s).....	C-3
Shock Absorber(s).....	F-4
Side Covers.....	G-4
Stand(s).....	E-11
Starter Motor.....	D-4
Steering Damper.....	F-10
Suspension.....	E-7
Swingarm.....	E-6
Taillight(s).....	G-6
Tensioner.....	B-11
Throttle.....	C-9
Tires.....	E-12
Top Feed Injector.....	C-10
Transmission.....	B-14
Turn Signals.....	G-7
Valve(s).....	B-10/B-9
Water Pipe.....	D-7

This catalog covers:

'08 ZX1000E8F

GRID NO.

H-16

This grid covers:

Part Name Index

Air Cleaner.....	B-5/B-6
Brake Pedal.....	F-3
Cables.....	G-3
Camshaft(s).....	B-11
Chain Cover.....	G-4
Chassis Electrical Equipment.....	G-8
Clutch.....	B-13
Cowling.....	H-3
Cowling Lowers.....	H-4
Crankcase.....	C-5
Crankcase Bolt Pattern.....	C-6
Crankshaft.....	B-12
Cylinder Head.....	B-3
Cylinder Head Cover.....	B-4
Decals(Black).....	G-13
Decals(Green).....	G-12
Decals(Orange).....	G-14
Engine Cover(s).....	C-7
Engine Mount.....	E-4
Footrests.....	E-8
Frame.....	E-3
Frame Fittings.....	E-5
Front Brake.....	F-6
Front Fender(s).....	E-9
Front Fork.....	F-11
Front Hub.....	E-13
Front Master Cylinder.....	F-5
Fuel Injection.....	C-12
Fuel Pump.....	C-11
Fuel Tank.....	F-12
Gear Change Drum.....	C-3
Gear Change Mechanism.....	C-4
Generator.....	C-14
Handlebar.....	F-9

Headlight(s).....	G-5
Ignition Switch.....	G-9
Ignition System.....	D-3
Labels.....	G-11
Meter(s).....	F-14
Muffler(s).....	B-7/B-8
Oil Cooler.....	D-6
Oil Pan.....	C-8
Oil Pump.....	C-13
Owner's Tools.....	G-10
Piston(s).....	B-12
Radiator.....	D-5
Rear Brake.....	F-8
Rear Fender(s).....	E-10
Rear Hub.....	E-14
Rear Master Cylinder.....	F-7
Seat.....	F-13
Shift Fork(s).....	C-3
Shock Absorber(s).....	F-4
Side Covers.....	G-4
Stand(s).....	E-11
Starter Motor.....	D-4
Steering Damper.....	F-10
Suspension.....	E-7
Swingarm.....	E-6
Taillight(s).....	G-6
Tensioner.....	B-11
Throttle.....	C-9
Tires.....	E-12
Top Feed Injector.....	C-10
Transmission.....	B-14
Turn Signals.....	G-7
Valve(s).....	B-10/B-9
Water Pipe.....	D-7