

This catalog covers:

'07~'08 ZR750 L7F/L8F

GRID NO.

A-1

This grid covers:

Title



PARTS CATALOG

'07~'08 ZR750 L7F/L8F

(Z750)

Publications	A-2
Model Identification	A-4
Engine	B-1
Chassis	E-1

© Kawasaki Heavy Industries, Ltd. 2007

Engine No. Location:

RH side crankcase

Year & Model

Color

'07 ZR750L7F

- 1. Atomic Silver (17M)
- 2. Candy Lime Green (17P)
- 3. Ebony (H8)

VIN No. Range

Engine No. Range

JKAZR750LLA000001 ~ 024000

ZR750JE000001 ~

'08 ZR750L8F

- 1. Ebony (H8)
- 2. Metallic Ocean Blue (726)
- 3. Pearl Wildfire Orange (17H)

JKAZR750LLA024001 ~

ZR750JE000001 ~

This catalog covers:

'07~'08 ZR750 L7F/L8F

GRID NO.

A-2

This grid covers:

Publications

Year & Model	Owner's Manual	A&P Manual		Service Manual		Microfiche
		General	Supplement	Basic	Supplement	
2007 ZR750L7F	99976-1306(EN/FR/GE) 99976-1362(IT/ES/NL) 99986-1357(English)	99939-1321-01		99924-1381-01		99912-1494-02
2008 ZR750L8F	99976-1409(EN/FR/GE) 99976-1410(IT/ES/NL) 99986-1436(English)	See above		99924-1381-02		99912-1494-03

This catalog covers:

'07~'08 ZR750 L7F/L8F

GRID NO.

A-4

This grid covers:

Model I.D. '07~'08 ZR750 L7F/L8F

ZR750L7F

Left Side View

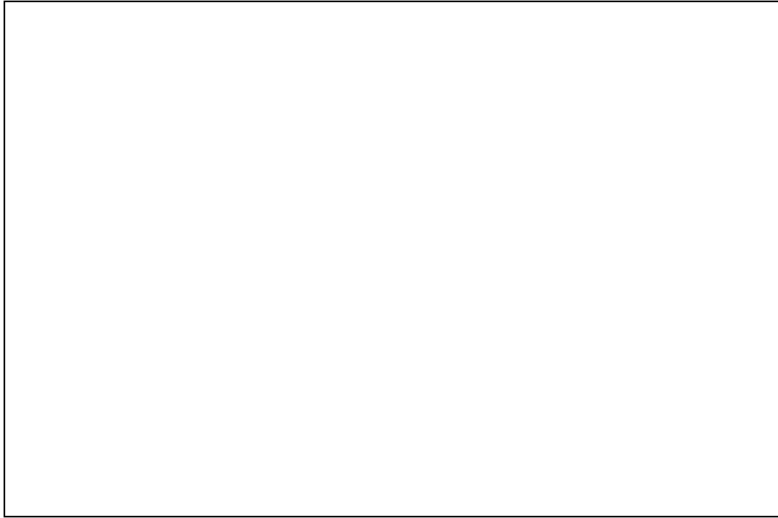

Right Side View

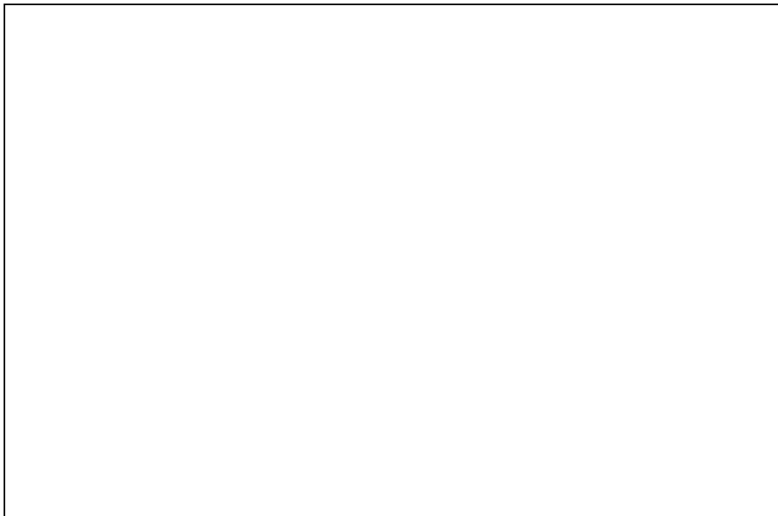

ZR750L8F

Left Side View

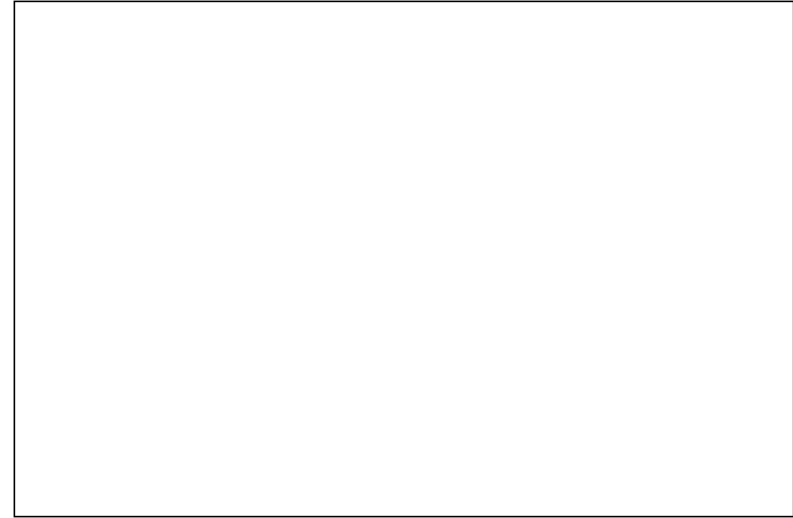

Right Side View

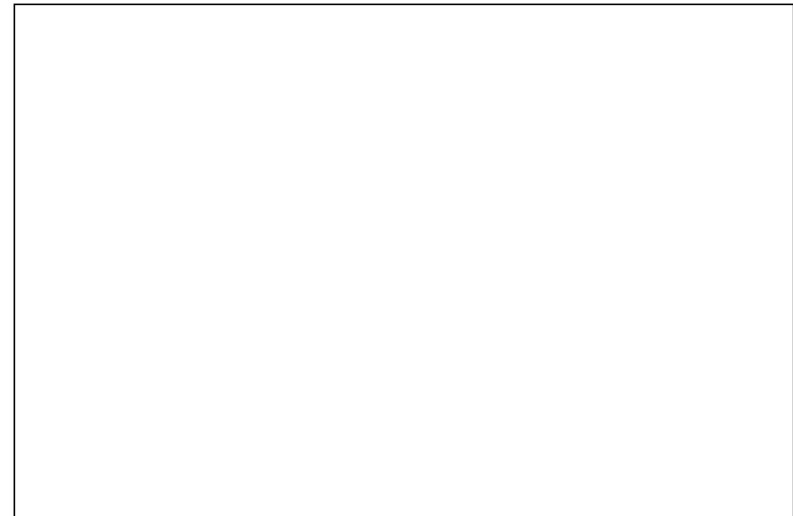

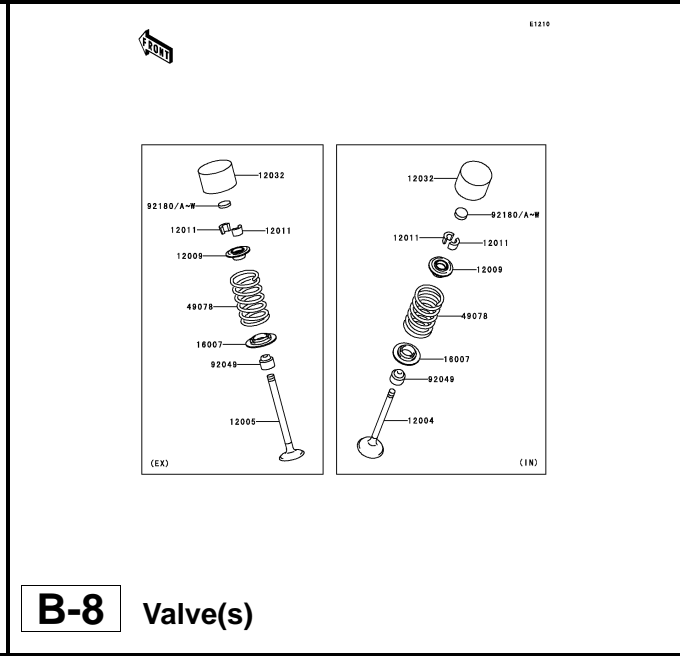
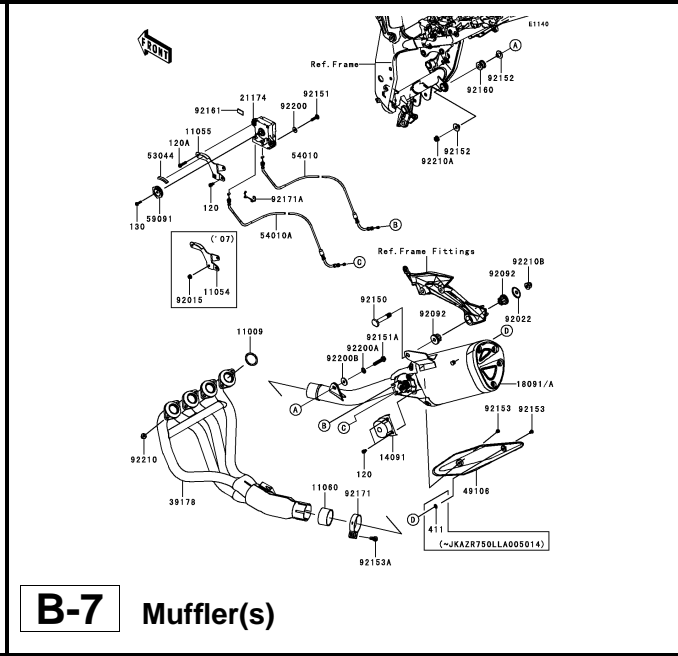
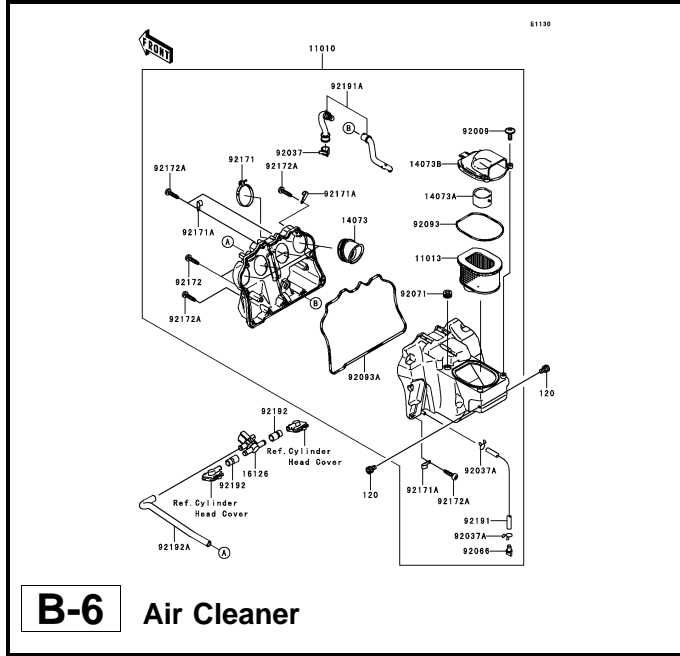
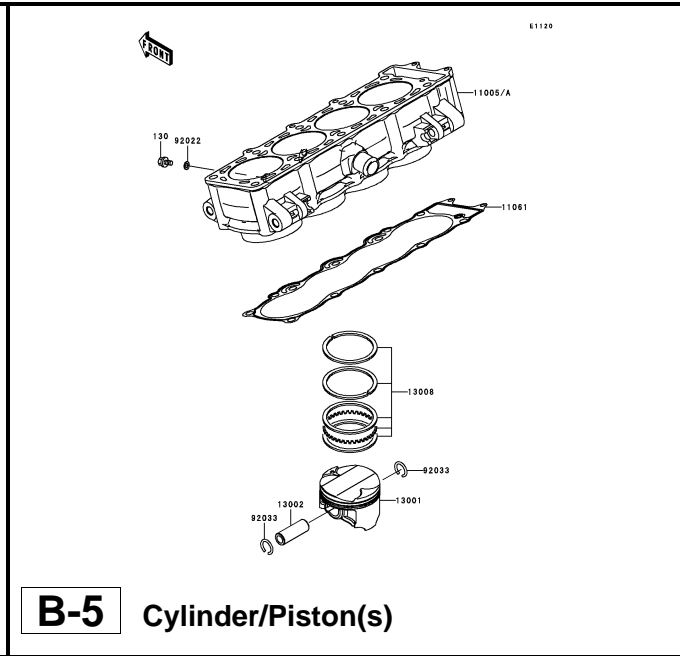
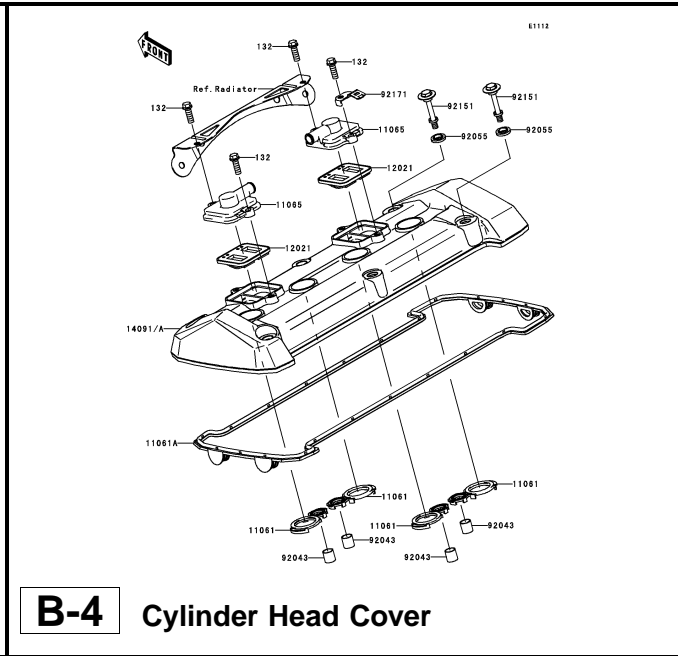
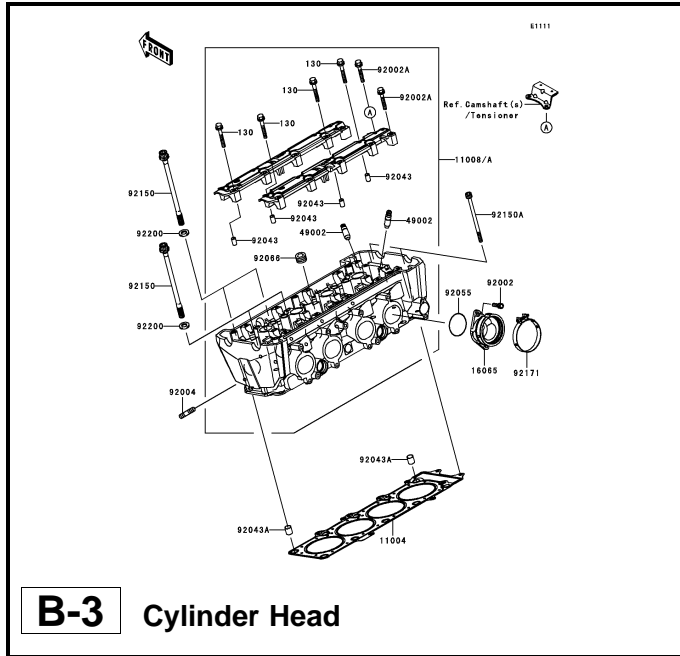

This catalog covers:

'07~'08 ZR750 L7F/L8F Engine

GRID NO.

B-2

This grid covers:

Pictorial Index

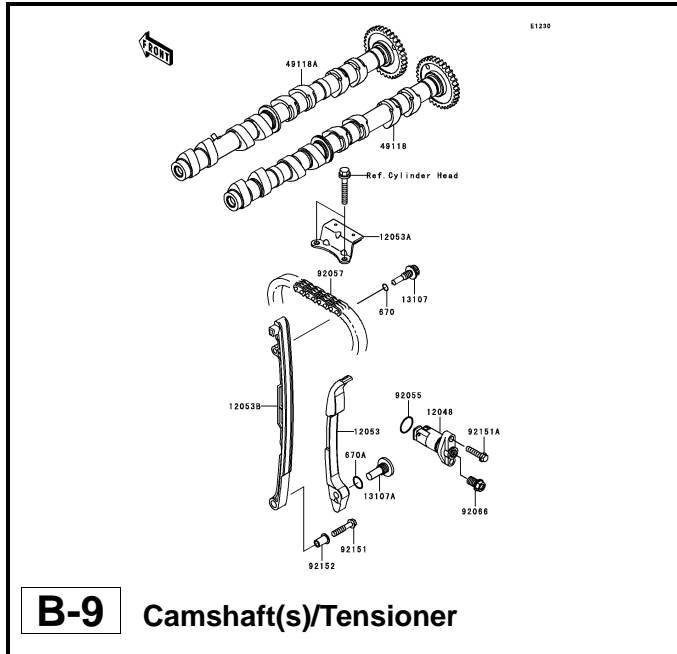

B-9 Camshaft(s)/Tensioner

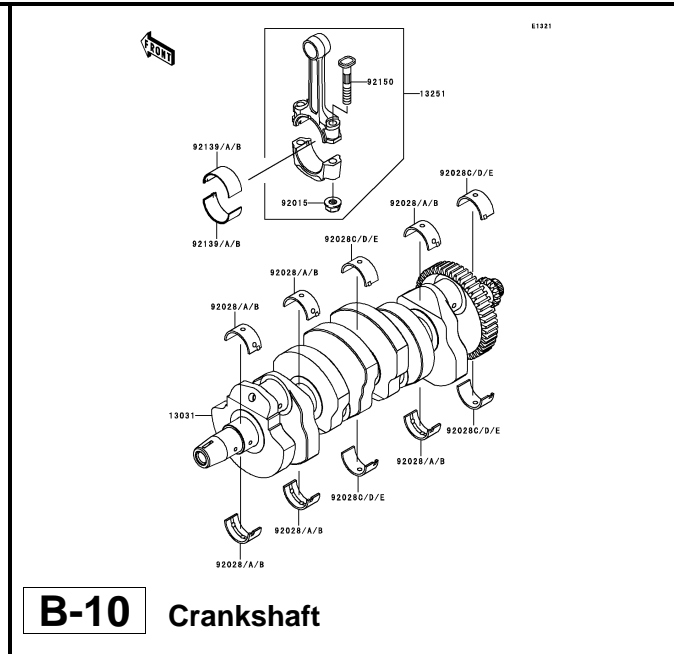

B-10 Crankshaft

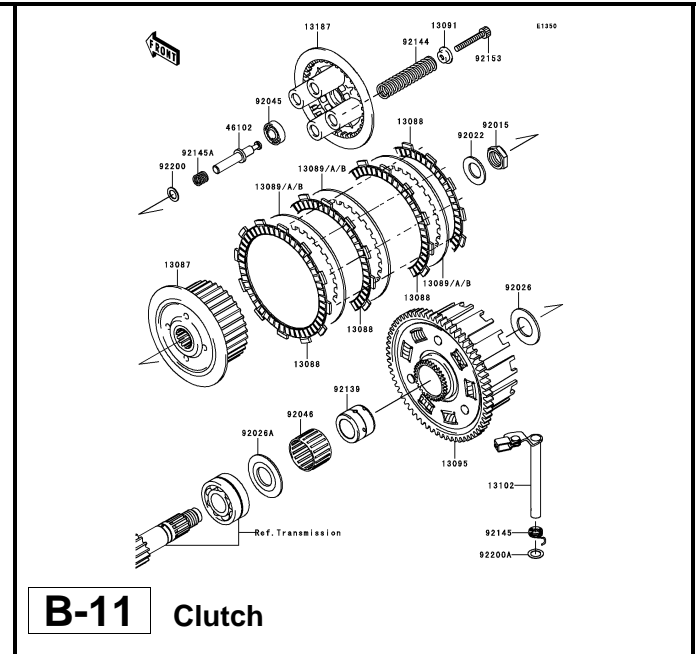

B-11 Clutch

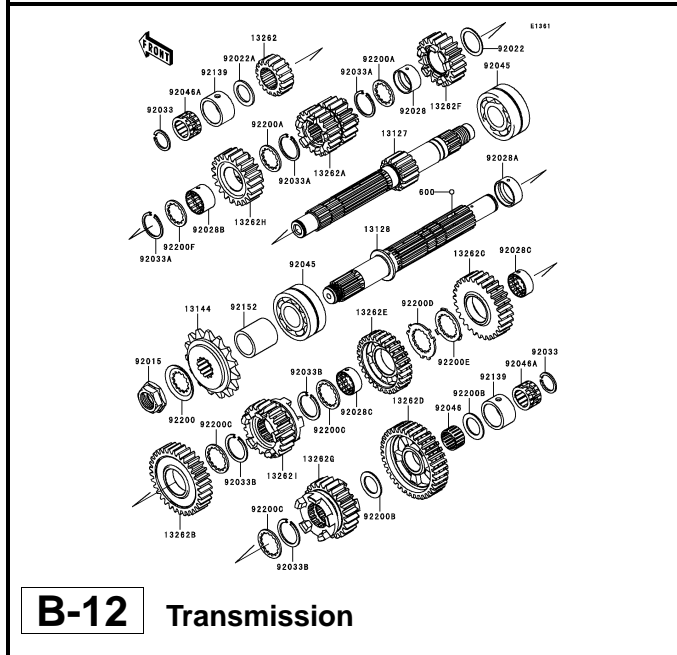

B-12 Transmission

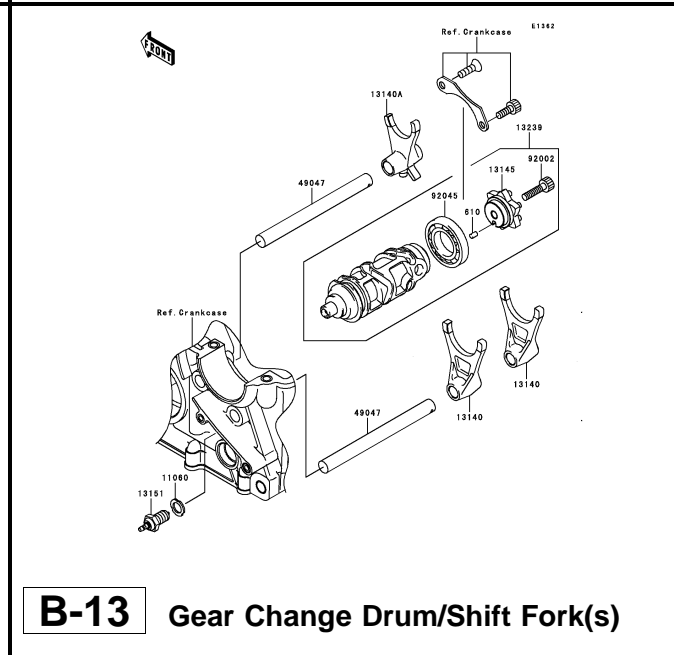

B-13 Gear Change Drum/Shift Fork(s)

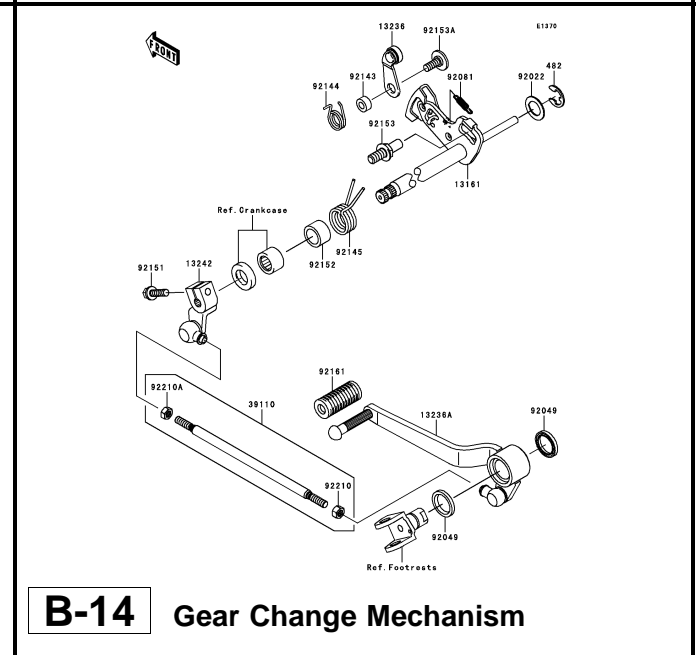

B-14 Gear Change Mechanism

This catalog covers:

'07~'08 ZR750 L7F/L8F Engine

GRID NO.

C-1

This grid covers:

Pictorial Index

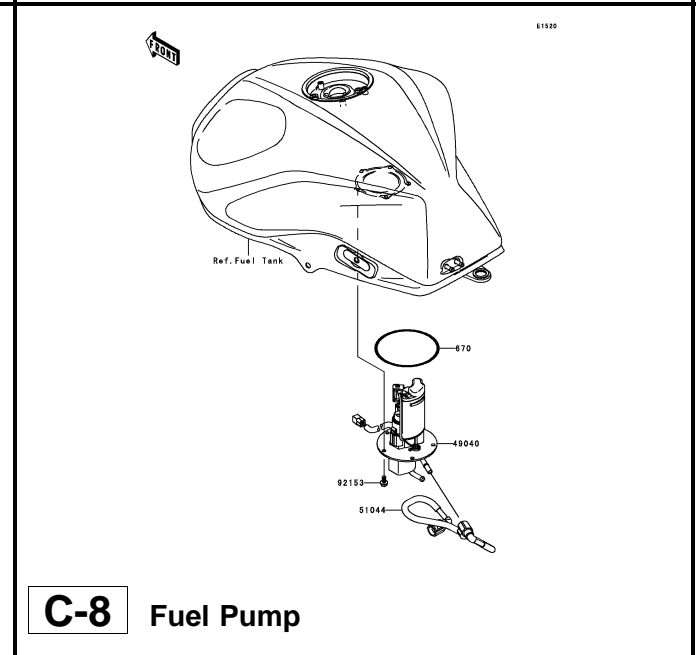
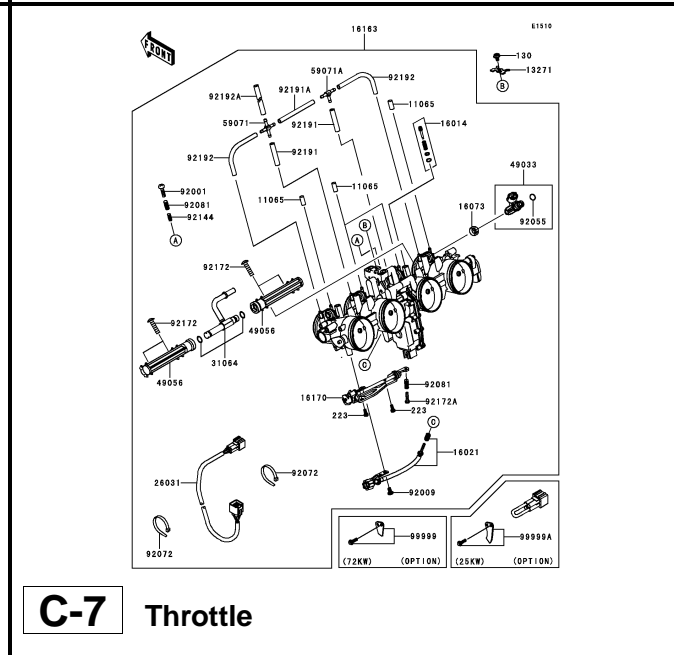
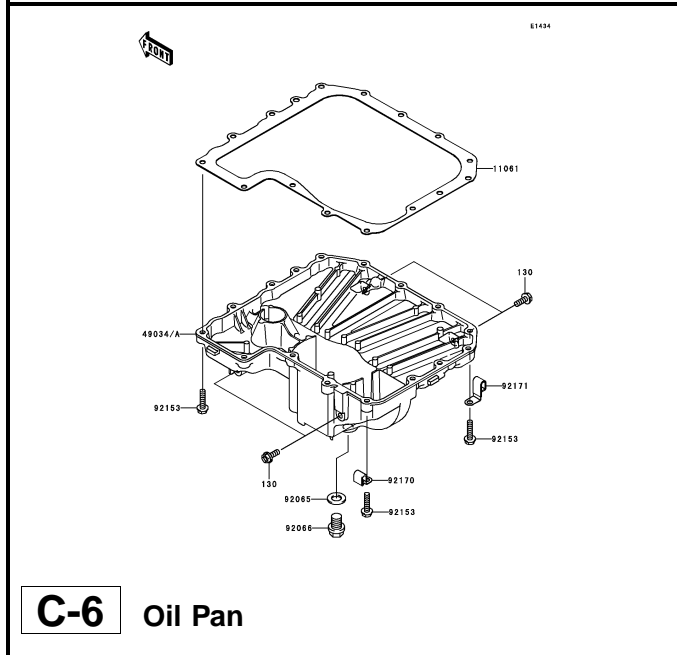
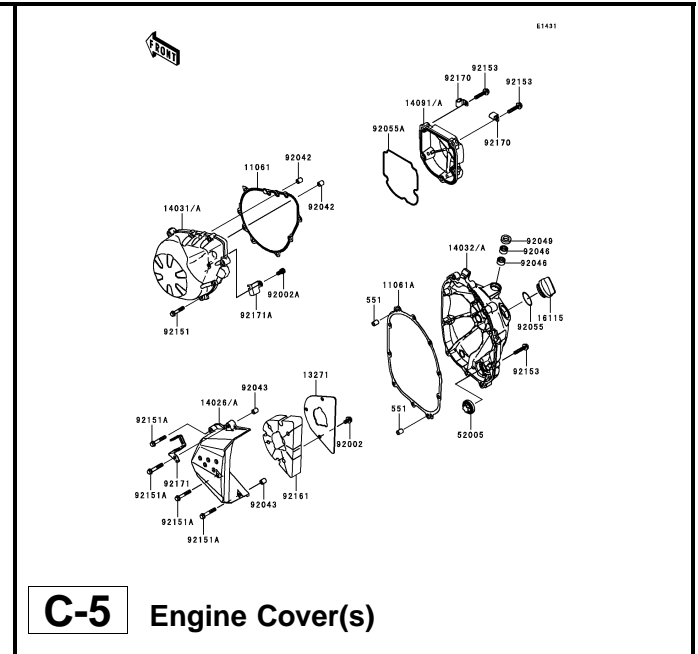
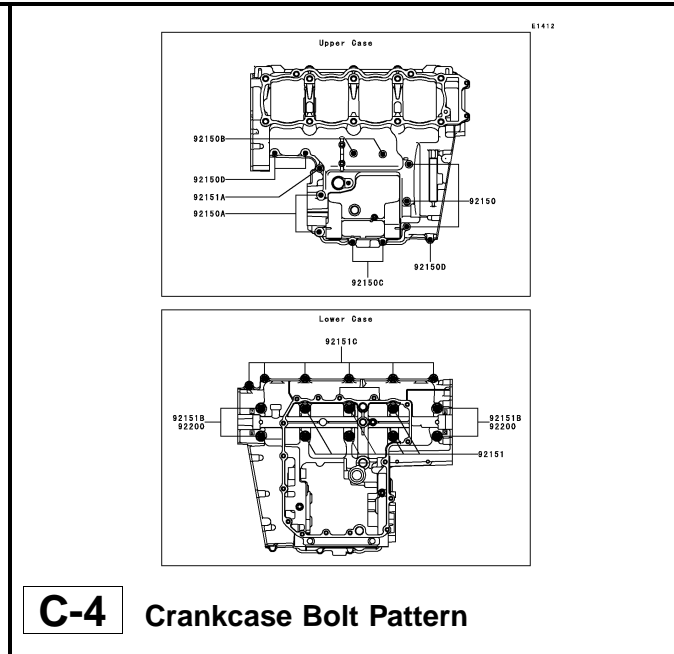
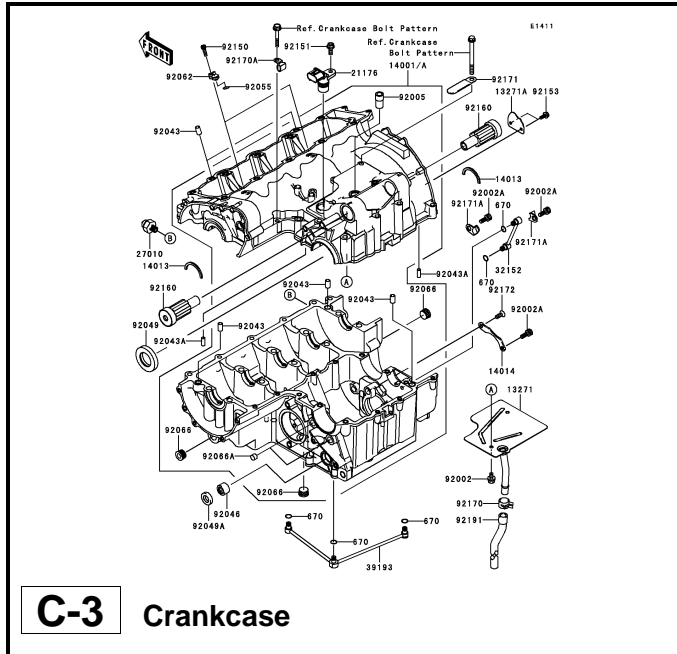

This catalog covers:

'07~'08 ZR750 L7F/L8F Engine

GRID NO.

D-1

This grid covers:

Pictorial Index

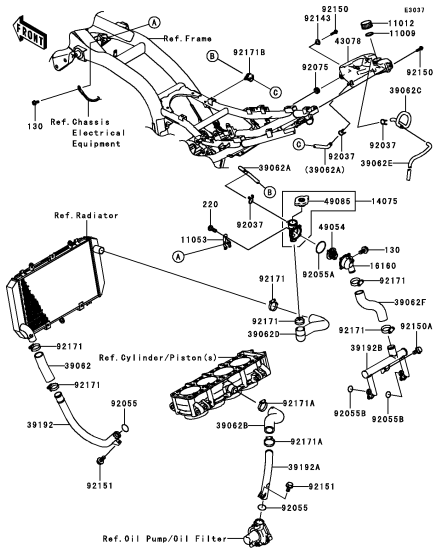

D-3 Water Pipe

This catalog covers:

'07~'08 ZR750 L7F/L8F Engine

GRID NO.

D-2

This grid covers:

Pictorial Index

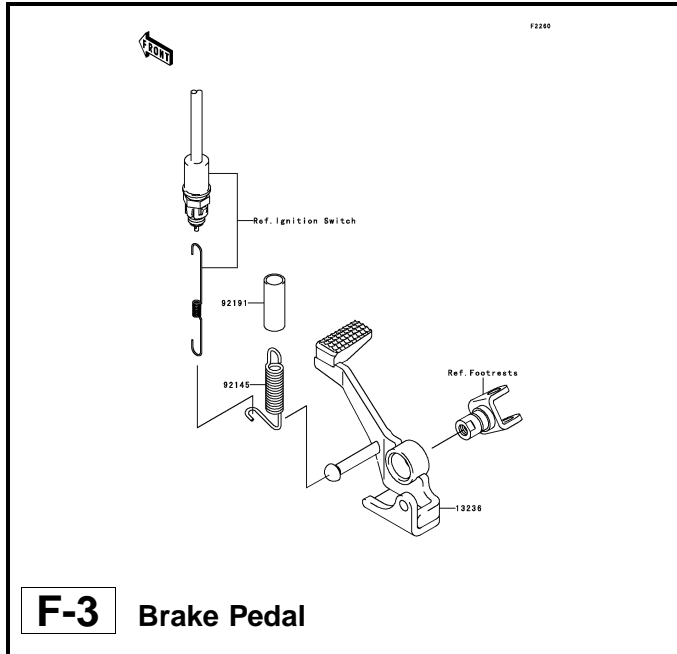

F-3 Brake Pedal

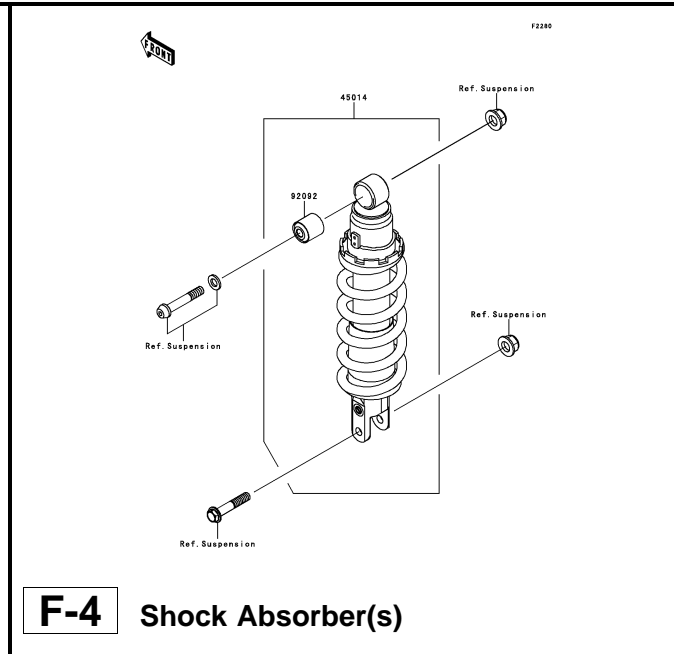

F-4 Shock Absorber(s)

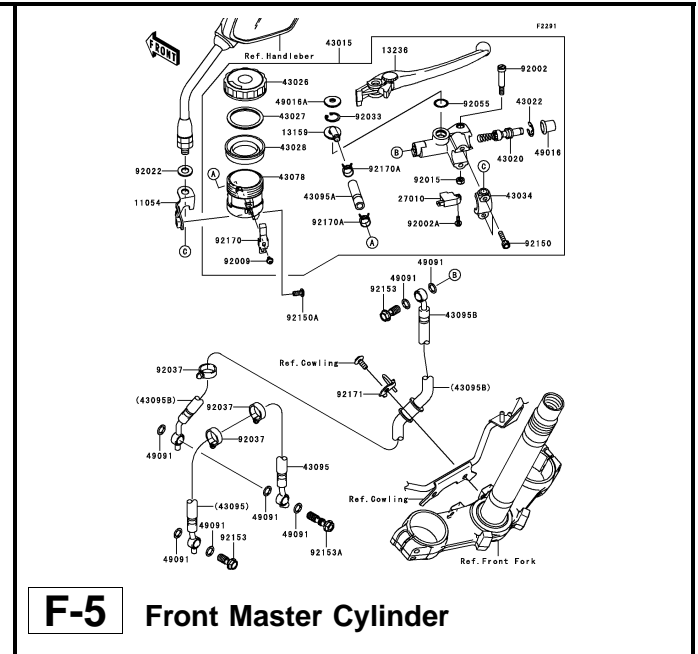

F-5 Front Master Cylinder

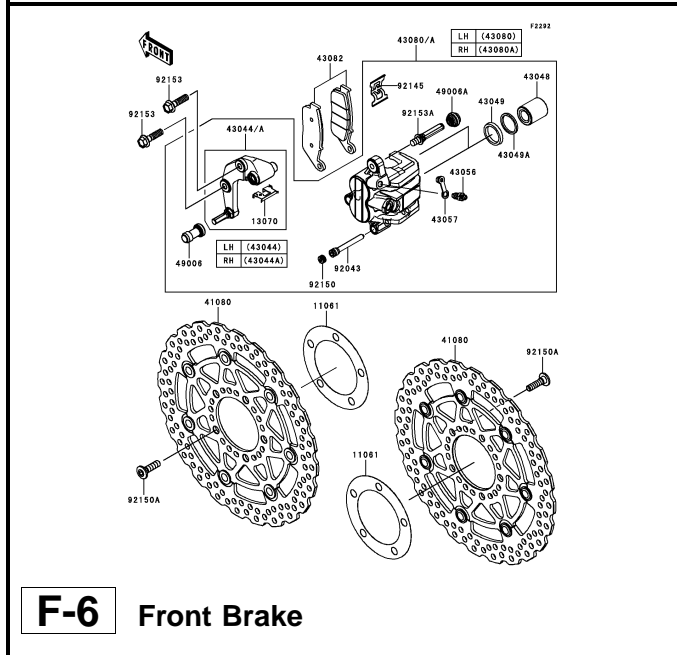

F-6 Front Brake

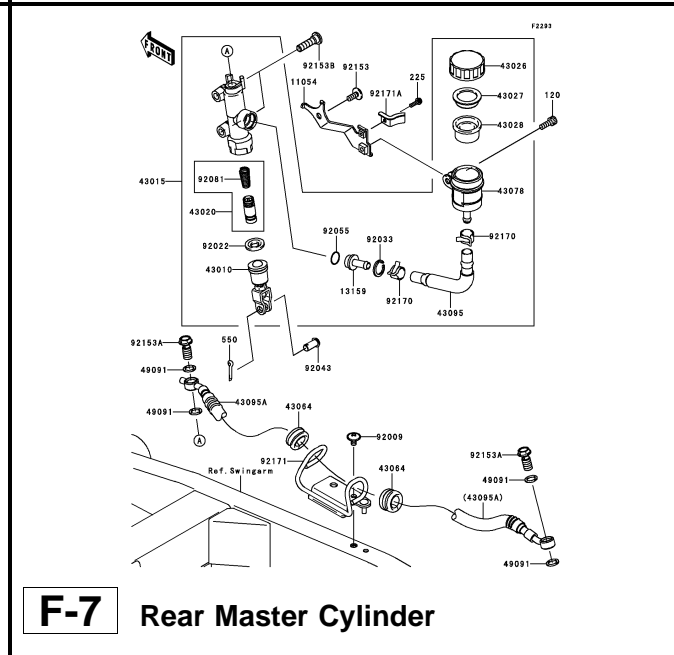

F-7 Rear Master Cylinder

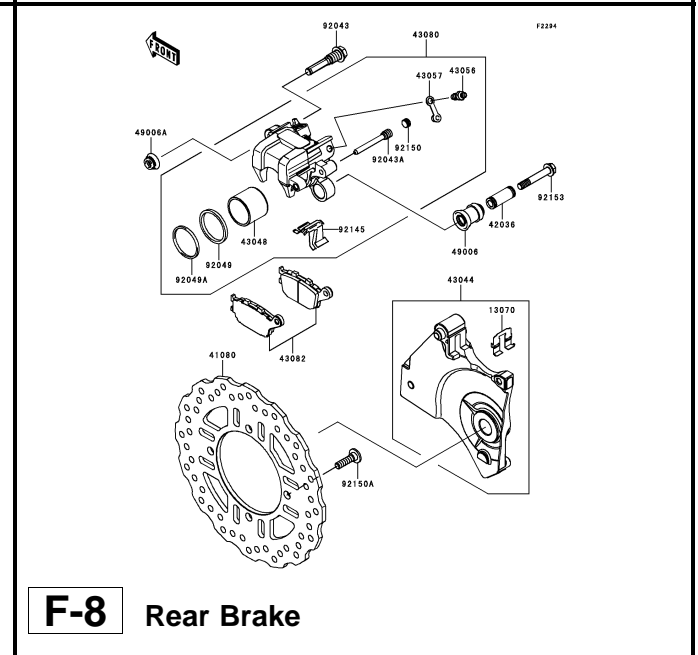

F-8 Rear Brake

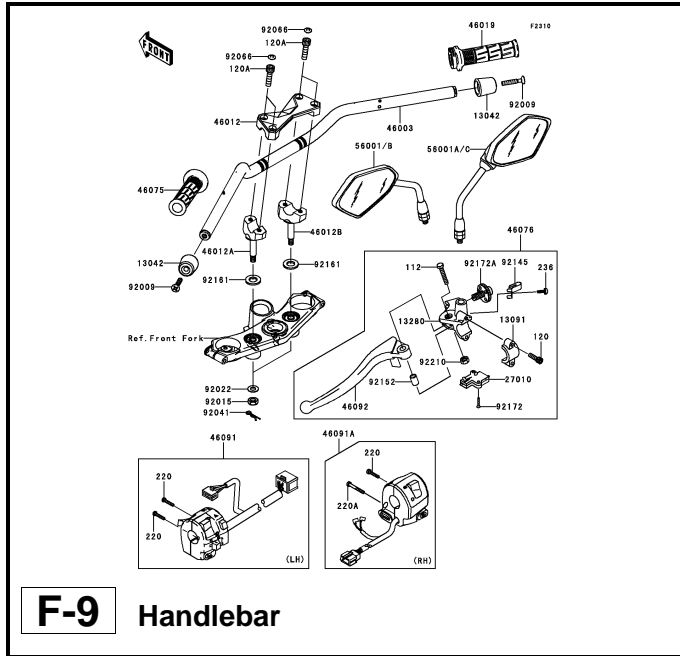

F-9 Handlebar

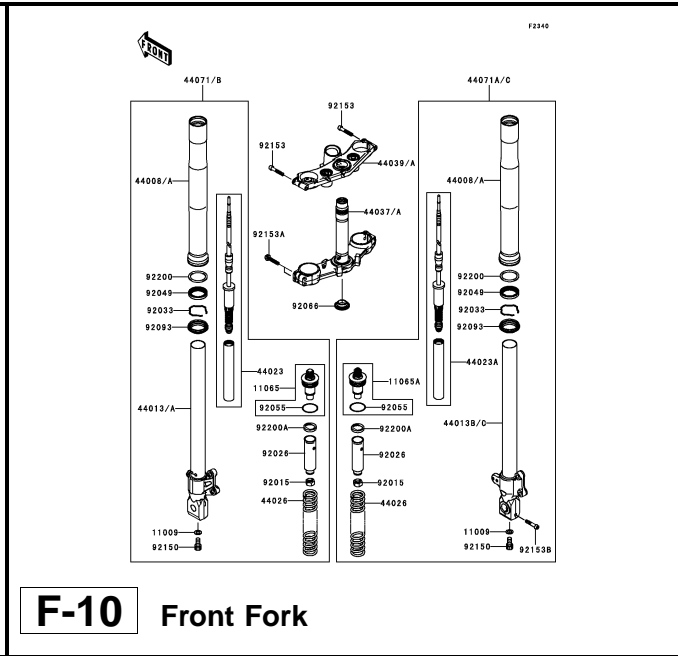

F-10 Front Fork

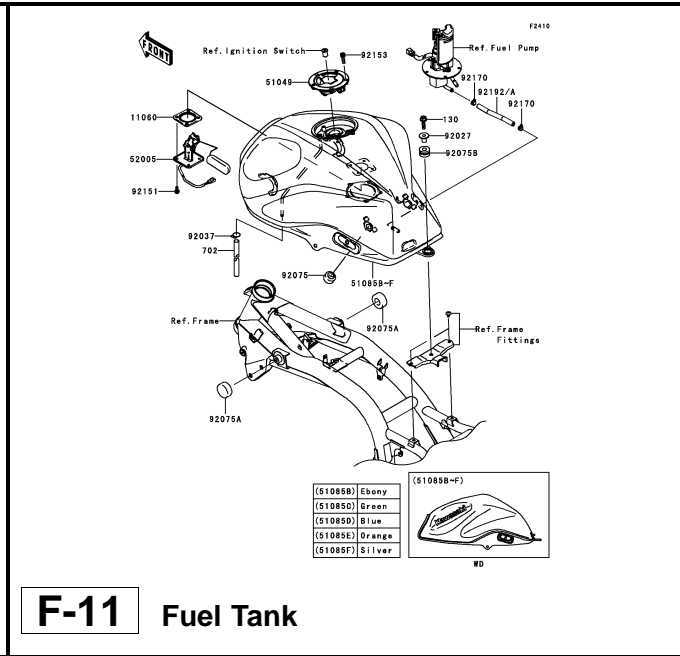

F-11 Fuel Tank

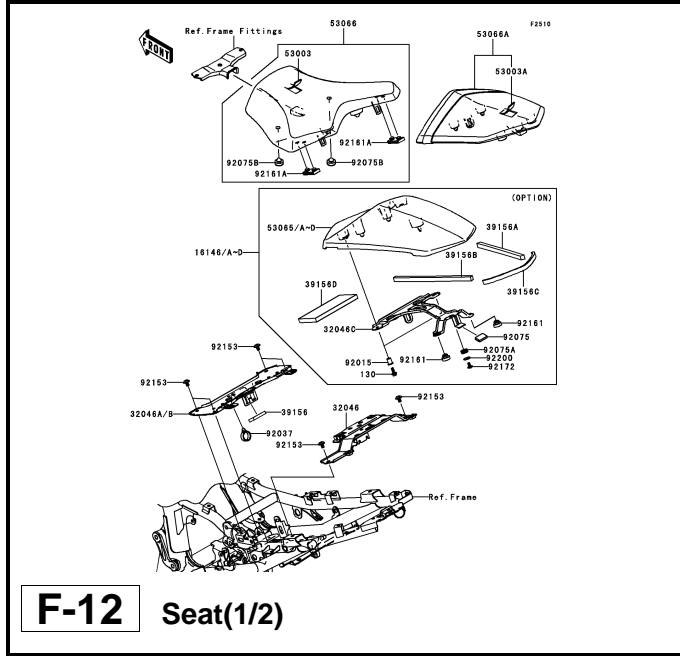

F-12 Seat(1/2)

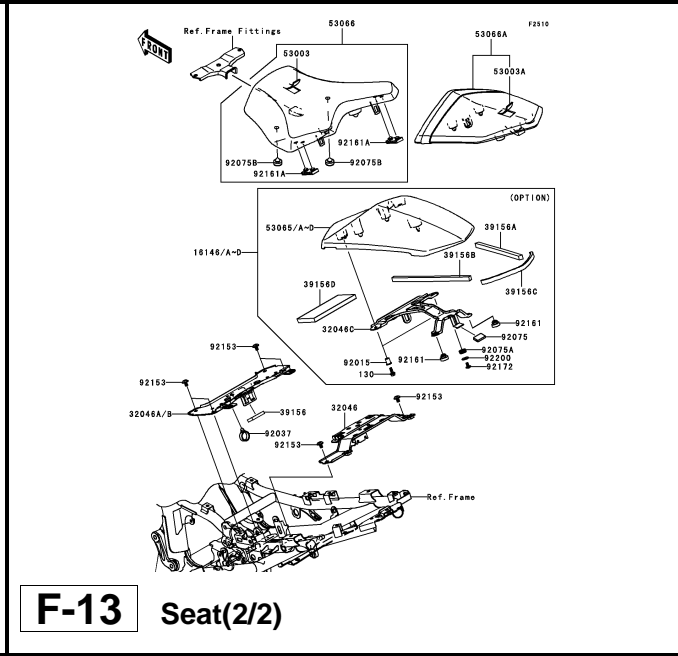

F-13 Seat(2/2)

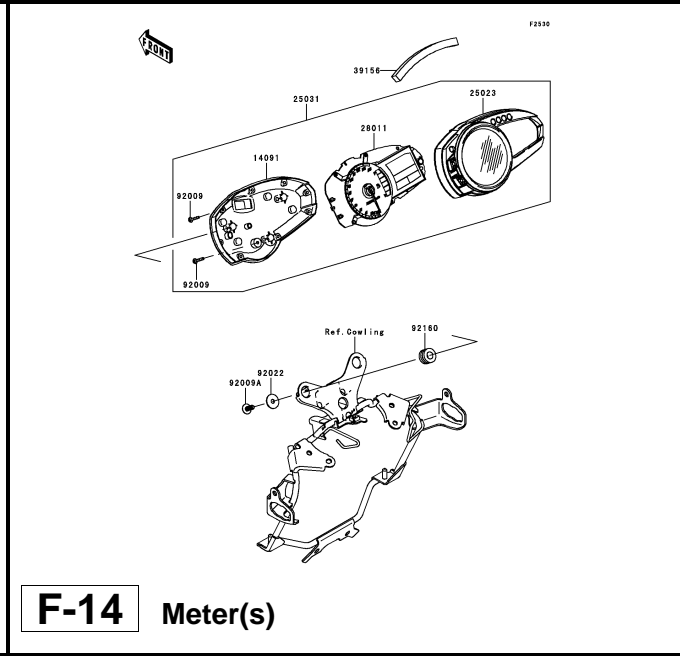

F-14 Meter(s)

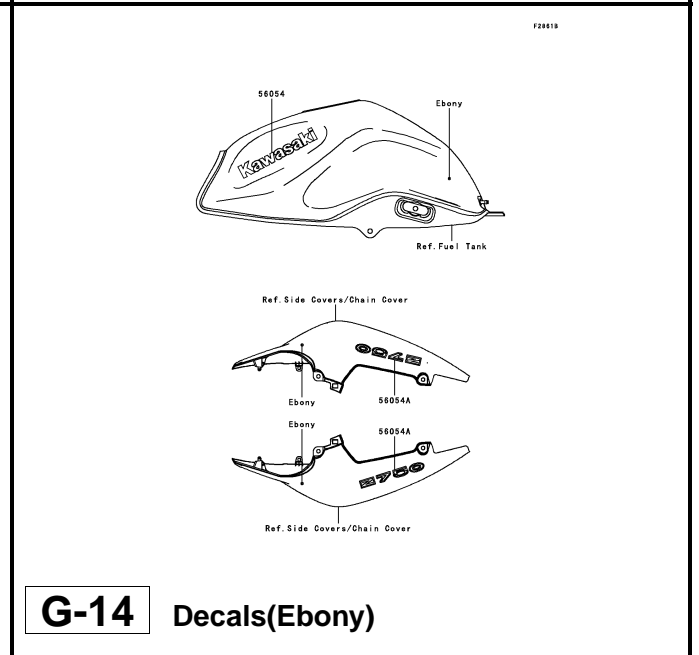
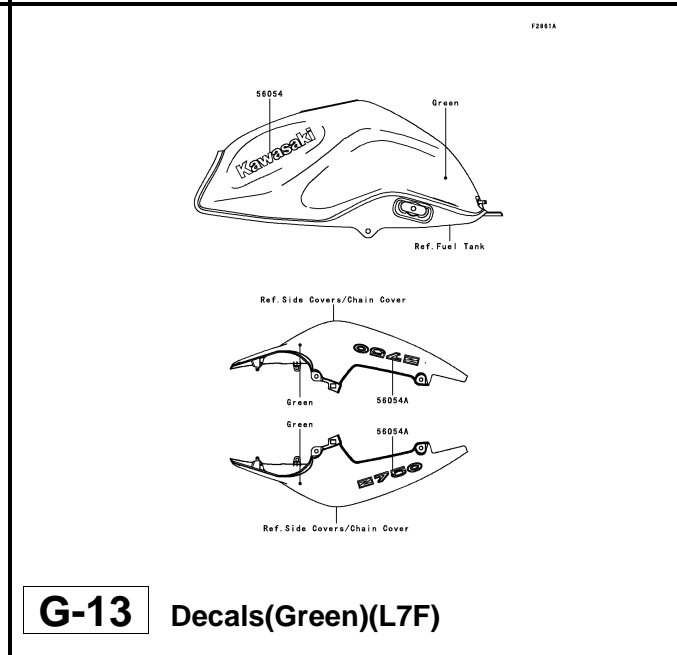
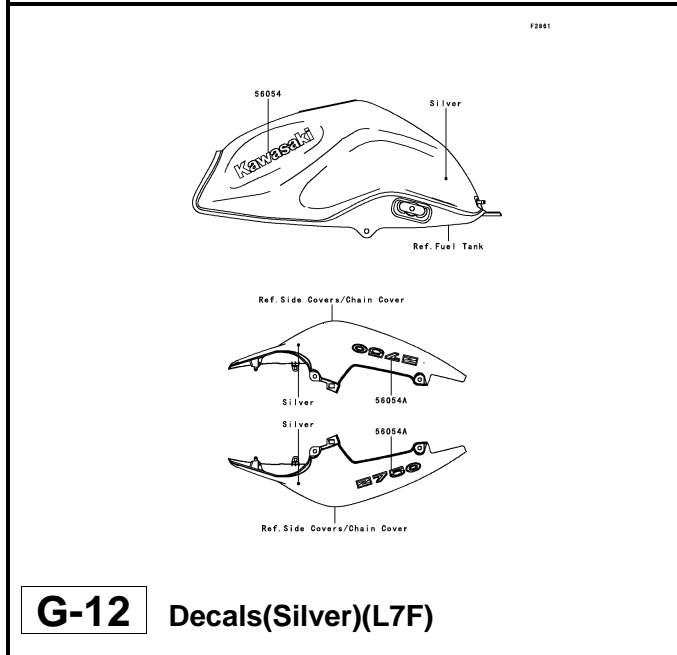
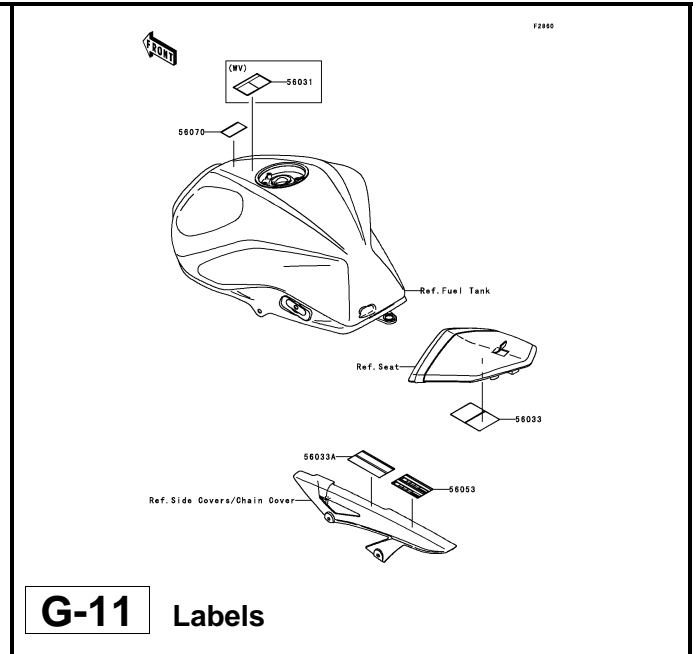
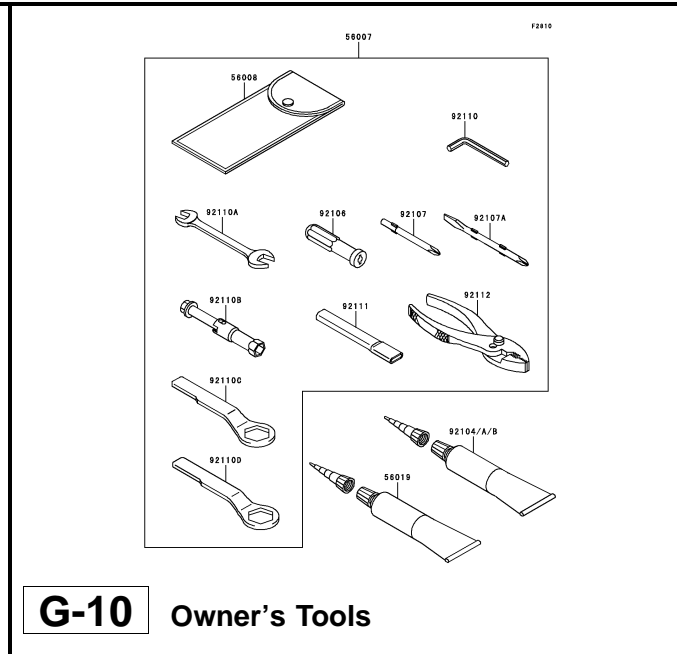
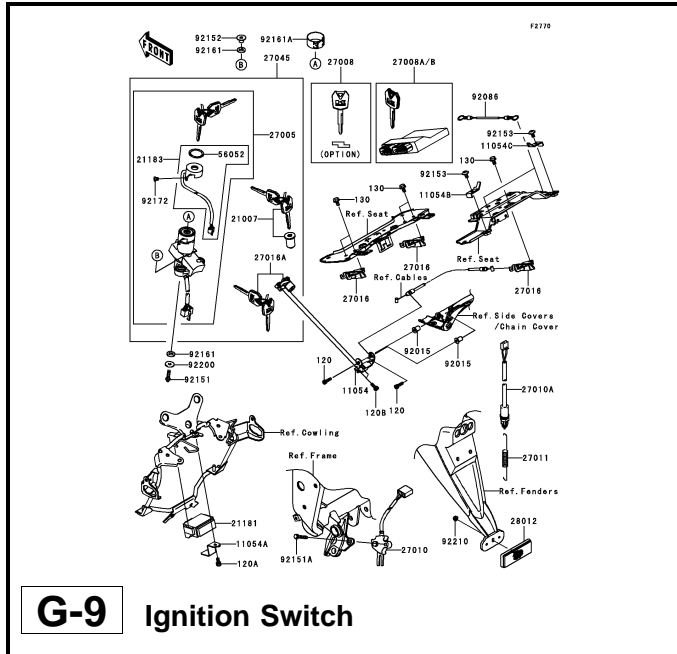

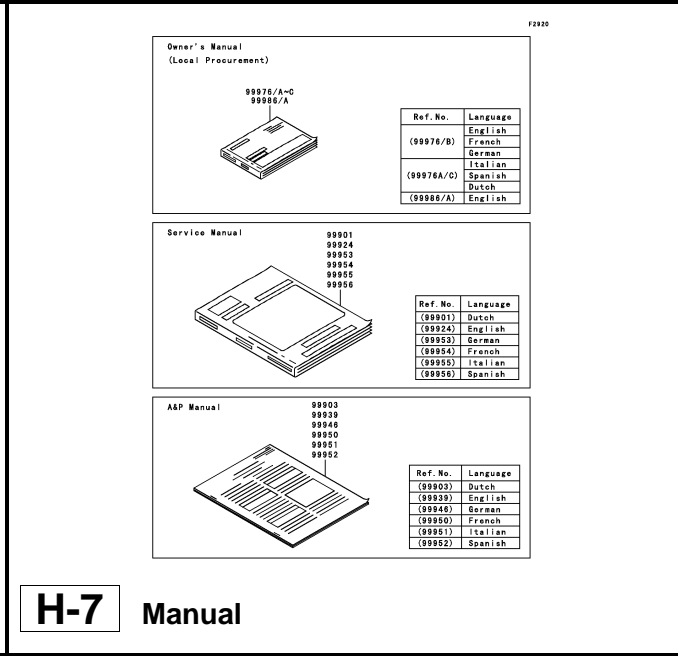
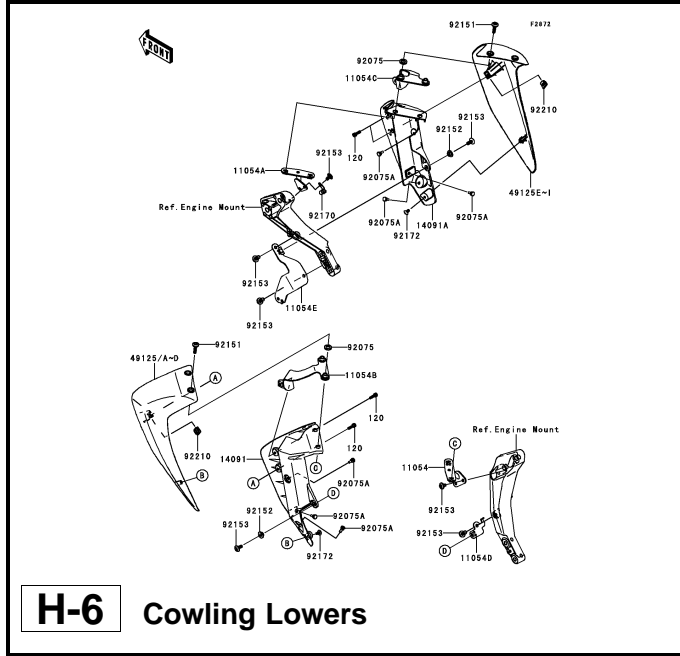
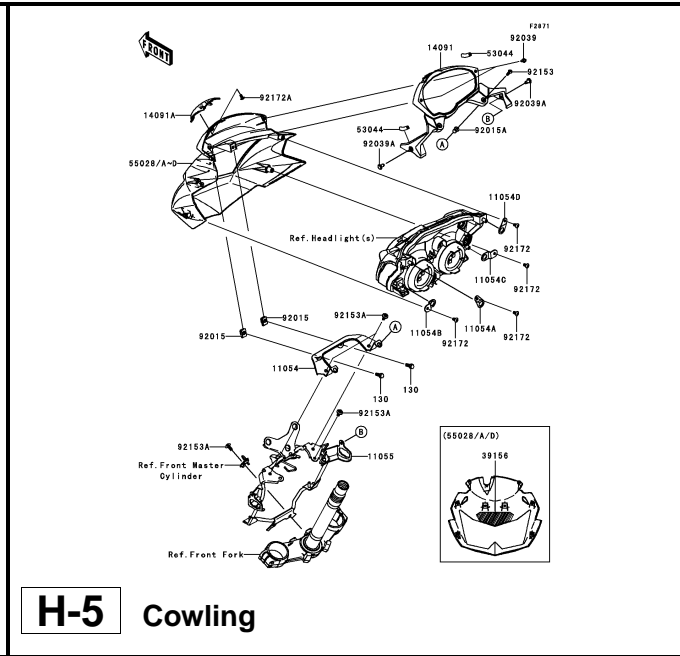
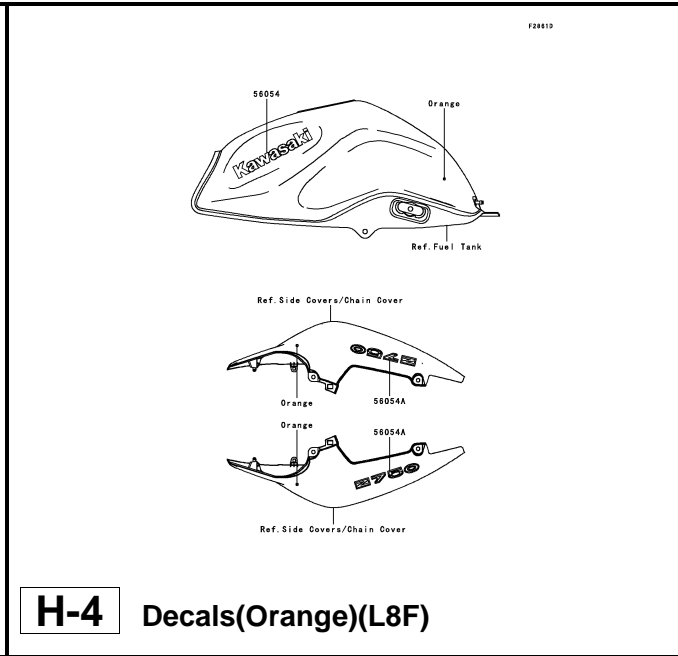
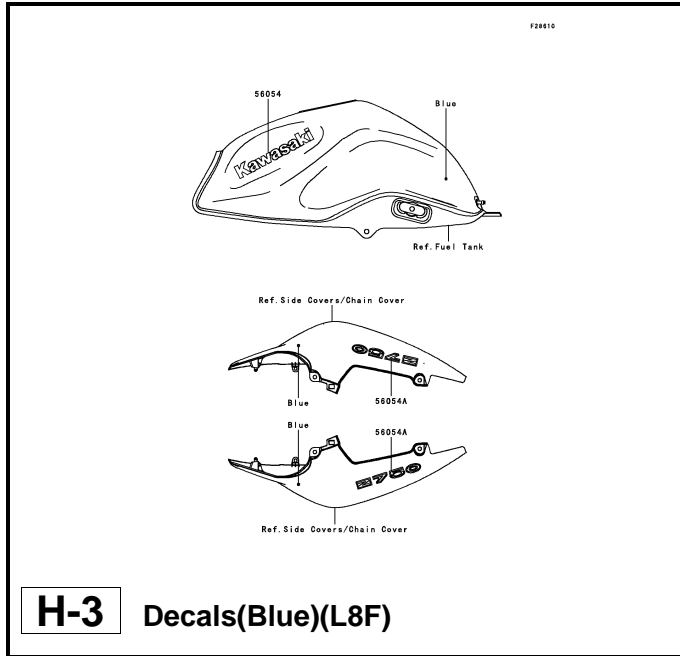

This catalog covers:

'07~'08 ZR750 L7F/L8F Chassis

GRID NO.

H-2

This grid covers:

Pictorial Index

This catalog covers:

'07~'08 ZR750 L7F/L8F Engine

GRID NO.

B-3

This grid covers:

Cylinder Head

E1111

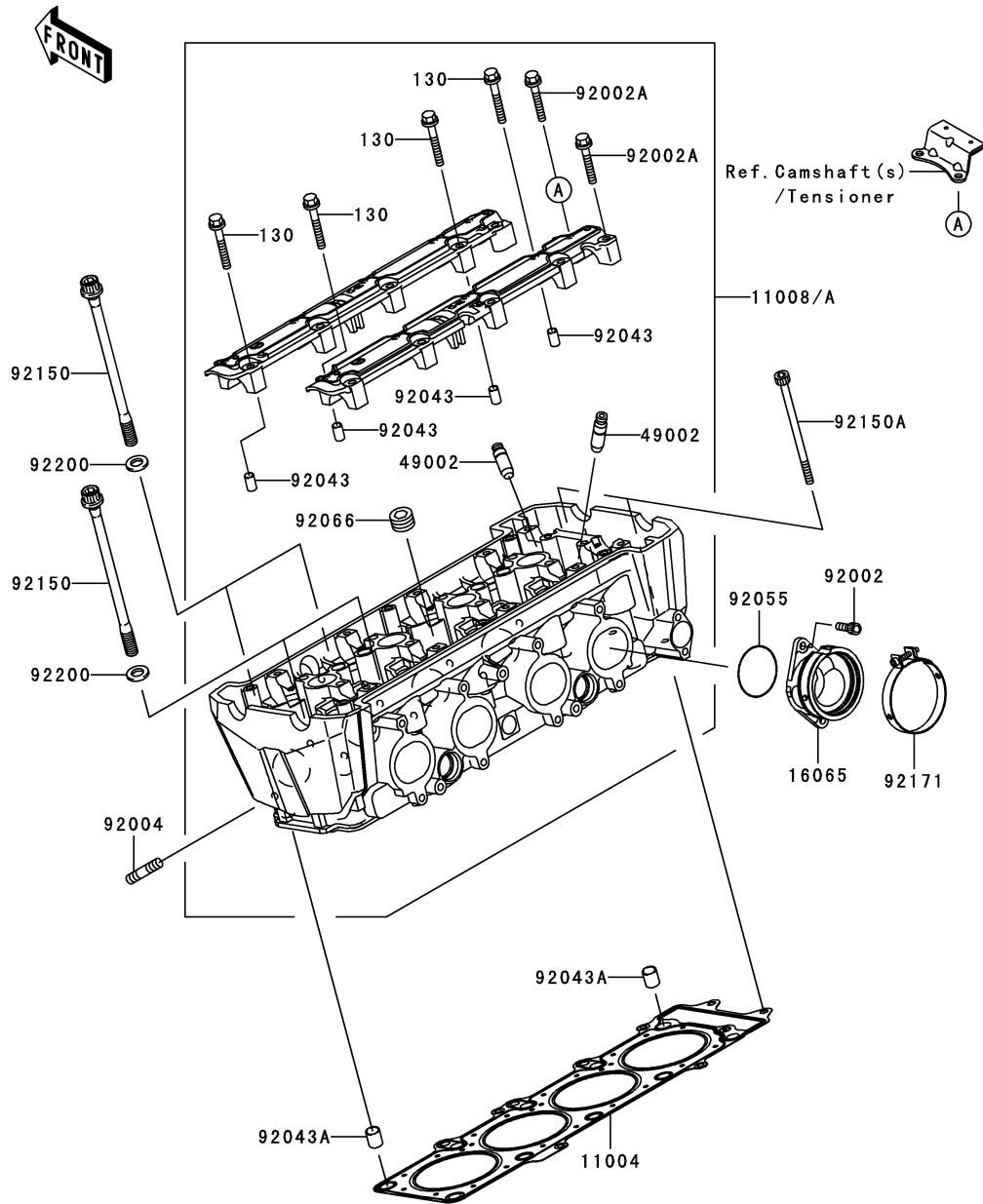

Ref. No.	Part No.	Description	Quantity-ZR750			
			'07	'08		
			L7F	L8F		
11004	11004-0074	GASKET-HEAD	1	1		
11008	11008-0093	HEAD-COMP-CYLINDER	1			
11008A	11008-0145	HEAD-COMP-CYLINDER		1		
16065	16065-0032	HOLDER-CARBURETOR	4	4		
49002	49002-1116	GUIDE-VALVE	AR	AR		
92002	92002-1143	BOLT,6X16	8	8		
92002A	92002-1756	BOLT,6X40	16	16		
92004	92004-0025	STUD,8X22	8	8		
92043	92043-1263	PIN,6.2X8X14	4	4		
92043A	92043-4009	PIN,10.1X12X14	2	2		
92055	92055-1401	RING-O,43.7X1.9	4	4		
92066	92066-0002	PLUG,PT1/2X12.5	5	5		
92150	92150-1368	BOLT,10X165	10	10		
92150A	92150-1755	BOLT,SOCKET,6X110	2	2		
92171	92171-1552	CLAMP	4	4		
92200	92200-0114	WASHER,10.5X19X2.3	10	10		
130	130P0645	BOLT-FLANGED,6X45	4	4		

This catalog covers:

'07~'08 ZR750 L7F/L8F Engine

GRID NO.

B-4

This grid covers:

Cylinder Head Cover

E1112

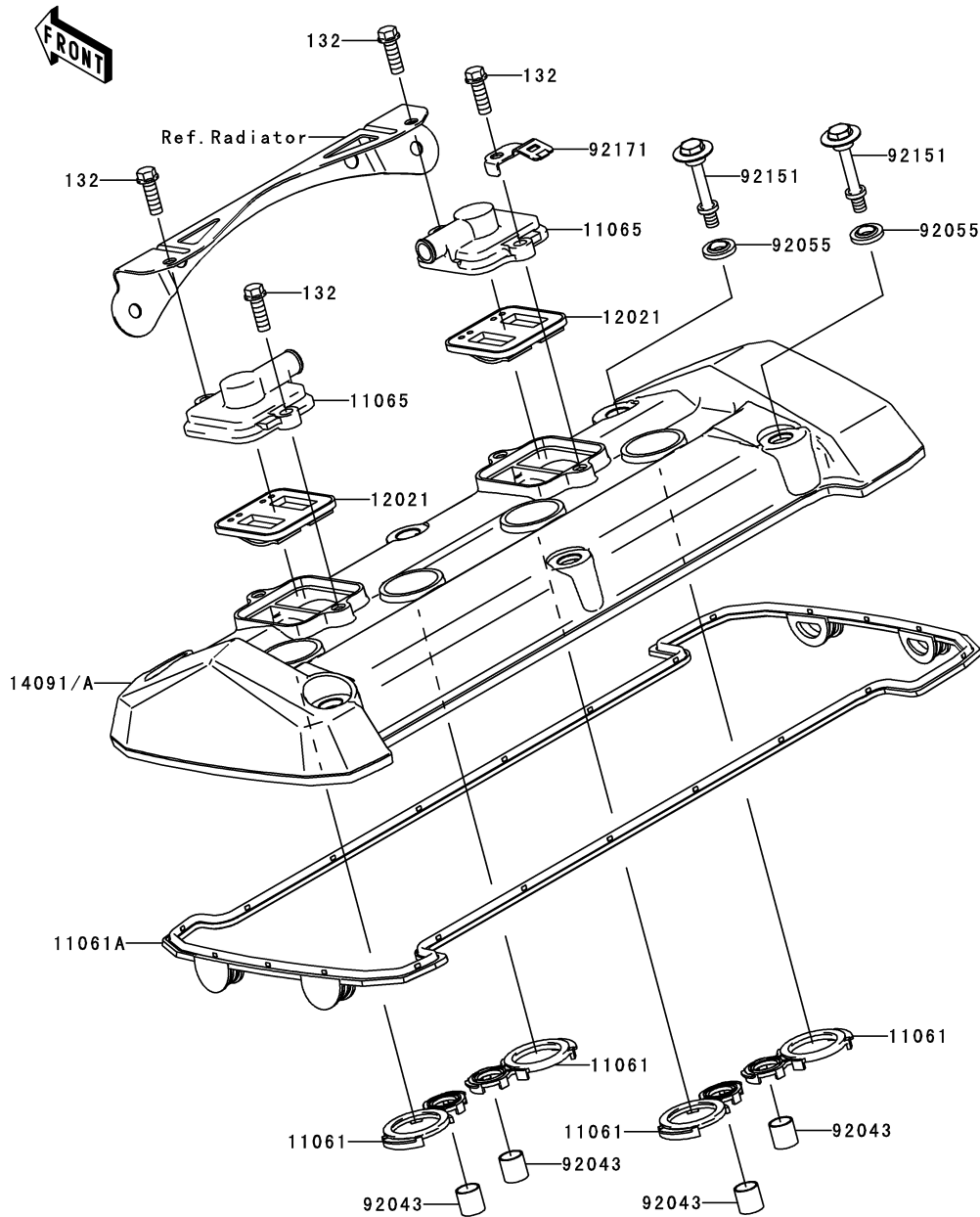

Ref. No.	Part No.	Description	Spec Code	Quantity-ZR750			
				'07	'08		
				L7F	L8F		
11061	11061-0104	GASKET,SPARK PLUG	4	4			
11061A	11061-0227	GASKET,HEAD COVER	1	1			
11065	11065-1247	CAP	2	2			
12021	12021-1130	VALVE-ASSY-REED	2	2			
14091	14091-0704	COVER,HEAD	1				
14091A	14091-0936	COVER,HEAD		1			
92043	92043-4009	PIN,10.1X12X14	4	4			
92055	92055-1352	RING-O,HEAD COVER BOLT	6	6			
92151	92151-1221	BOLT,HEAD COVER	6	6			
92171	92171-0920	CLAMP	1	1			
132	132G0618	BOLT-FLANGED-SMALL,6X18	4	4			

This catalog covers:

'07~'08 ZR750 L7F/L8F Engine

GRID NO.

B-5

This grid covers:

Cylinder/Piston(s)

E1120

Ref. No.	Part No.	Description	Spec Code	Quantity-ZR750			
				'07	'08		
				L7F	L8F		
11005	11005-0083	CYLINDER-ENGINE		1			
11005A	11005-0098	CYLINDER-ENGINE			1		
11061	11061-1168	GASKET,CYLINDER BASE		1	1		
13001	13001-0018	PISTON-ENGINE		4	4		
13002	13002-0022	PIN-PISTON		4	4		
13008	13008-0004	RING-SET-PISTON		4	4		
92022	92022-304	WASHER,6.2X11X1		1	1		
92033	92033-1099	RING-SNAP,20.5X1.2		8	8		
130	130Y0610	BOLT-FLANGED,6X10		1	1		

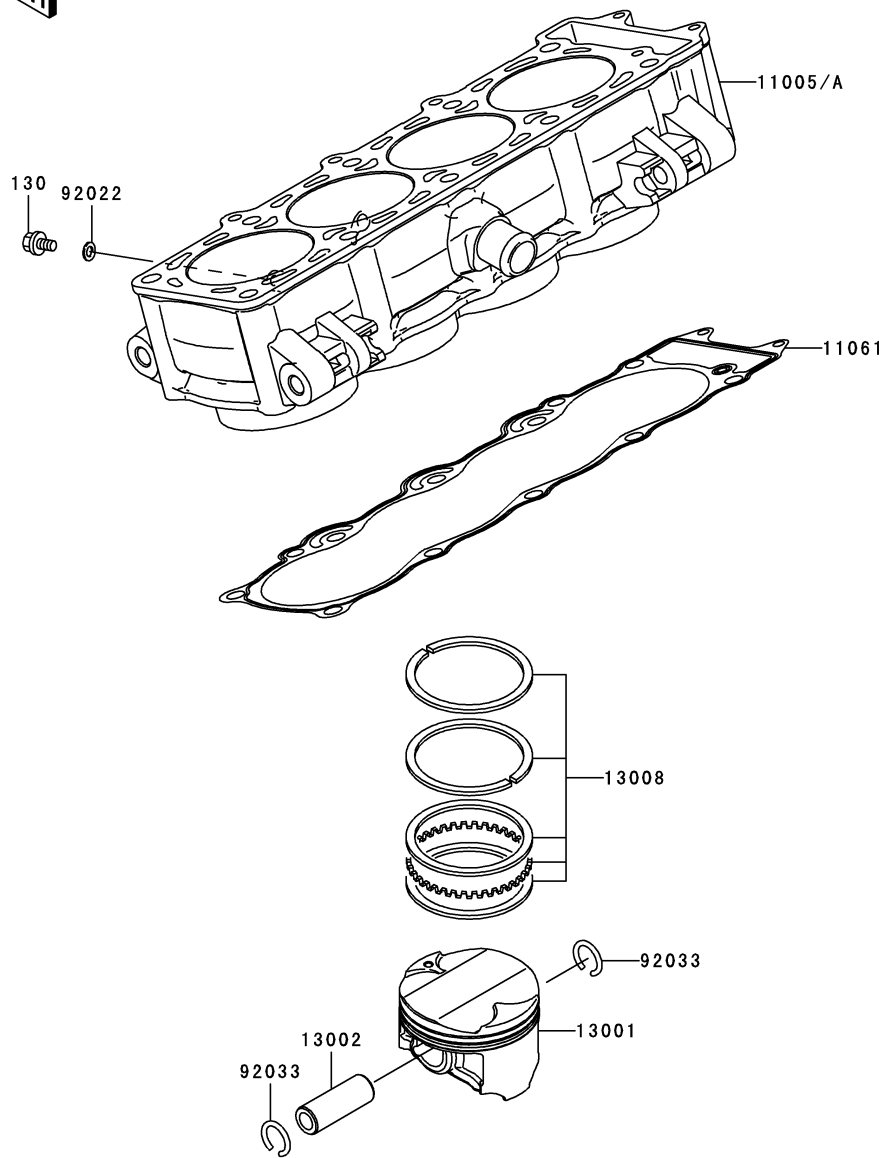

This catalog covers:

'07~'08 ZR750 L7F/L8F Engine

GRID NO.

B-6

This grid covers:

Air Cleaner

E1130

Ref. No.	Part No.	Description	Spec Code	Quantity-ZR750			
				'07	'08		
				L7F	L8F		
11010	11010-0126	FILTER-ASSY-AIR			1	1	
11013	11013-1302	ELEMENT-AIR FILTER			1	1	
14073	14073-0113	DUCT,FUNNEL			4	4	
14073A	14073-0157	DUCT,INTAKE			1	1	
14073B	14073-0164	DUCT,INTAKE TOP			1	1	
16126	16126-1437	VALVE,AIR SWITCHING			1	1	
92009	92009-1621	SCREW,6X16			2	2	
92037	92037-1460	CLAMP,HOSE CLIP			1	1	
92037A	92037-147	CLAMP,TUBE			2	2	
92066	92066-1211	PLUG,DRAIN			1	1	
92071	92071-2140	GROMMET			1	1	
92093	92093-0002	SEAL			1	1	
92093A	92093-0063	SEAL			1	1	
92171	92171-0815	CLAMP,OVAL,66MM			4	4	
92171A	92171-1539	CLAMP			3	3	
92172	92172-0009	SCREW,TAPPING,5X20			2	2	
92172A	92172-0056	SCREW-PAN-CROS,5X25			11	11	
92191	92191-0019	TUBE,7X10X320			1	1	
92191A	92191-1783	TUBE			1	1	
92192	92192-0033	TUBE,HEAD-ASV			2	2	
92192A	92192-0321	TUBE,ASV-A/C			1	1	
120	120CA0608	BOLT-SOCKET,6X8			2	2	

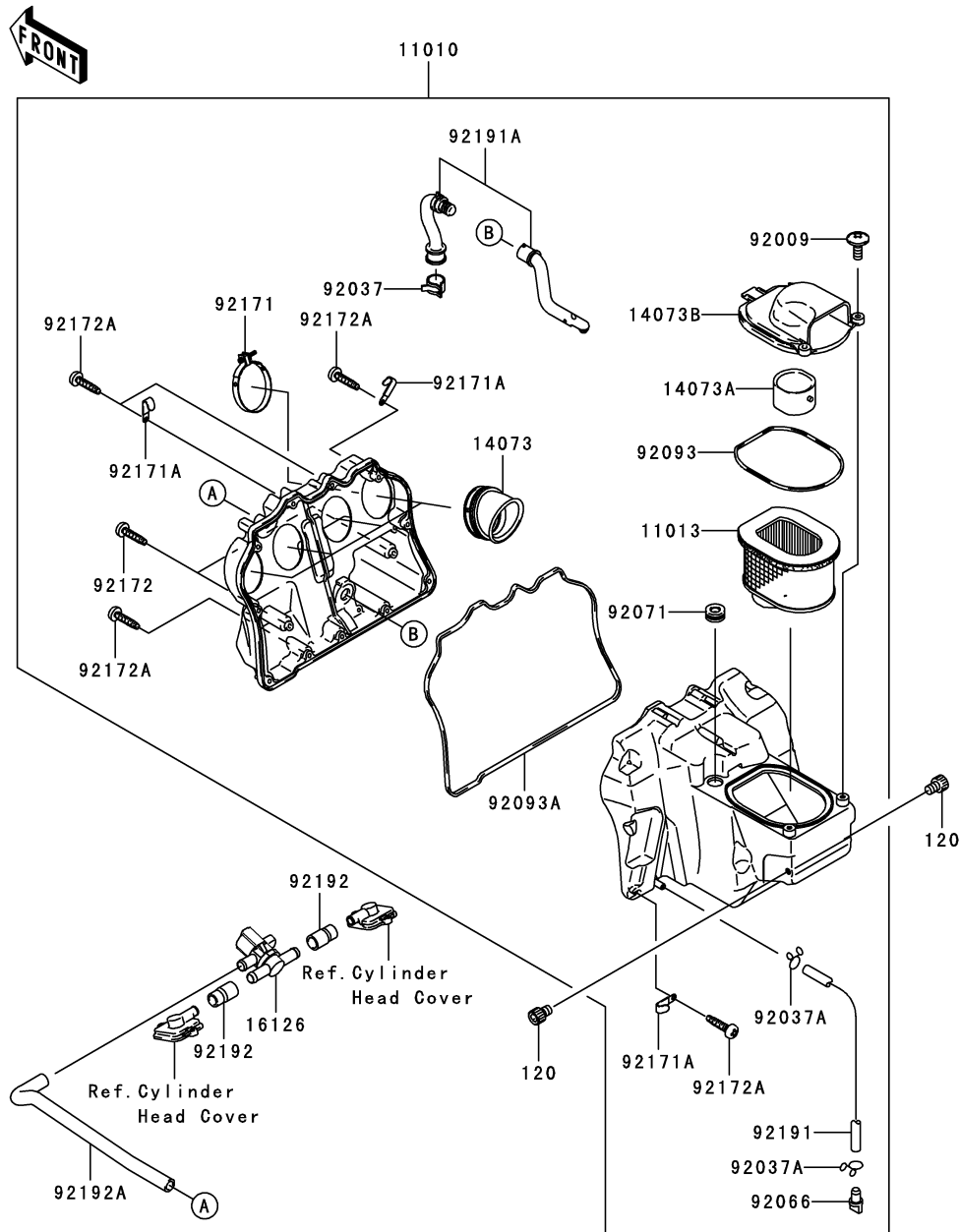

This catalog covers:

'07~'08 ZR750 L7F/L8F Engine

GRID NO.

B-7

This grid covers:

Muffler(s)

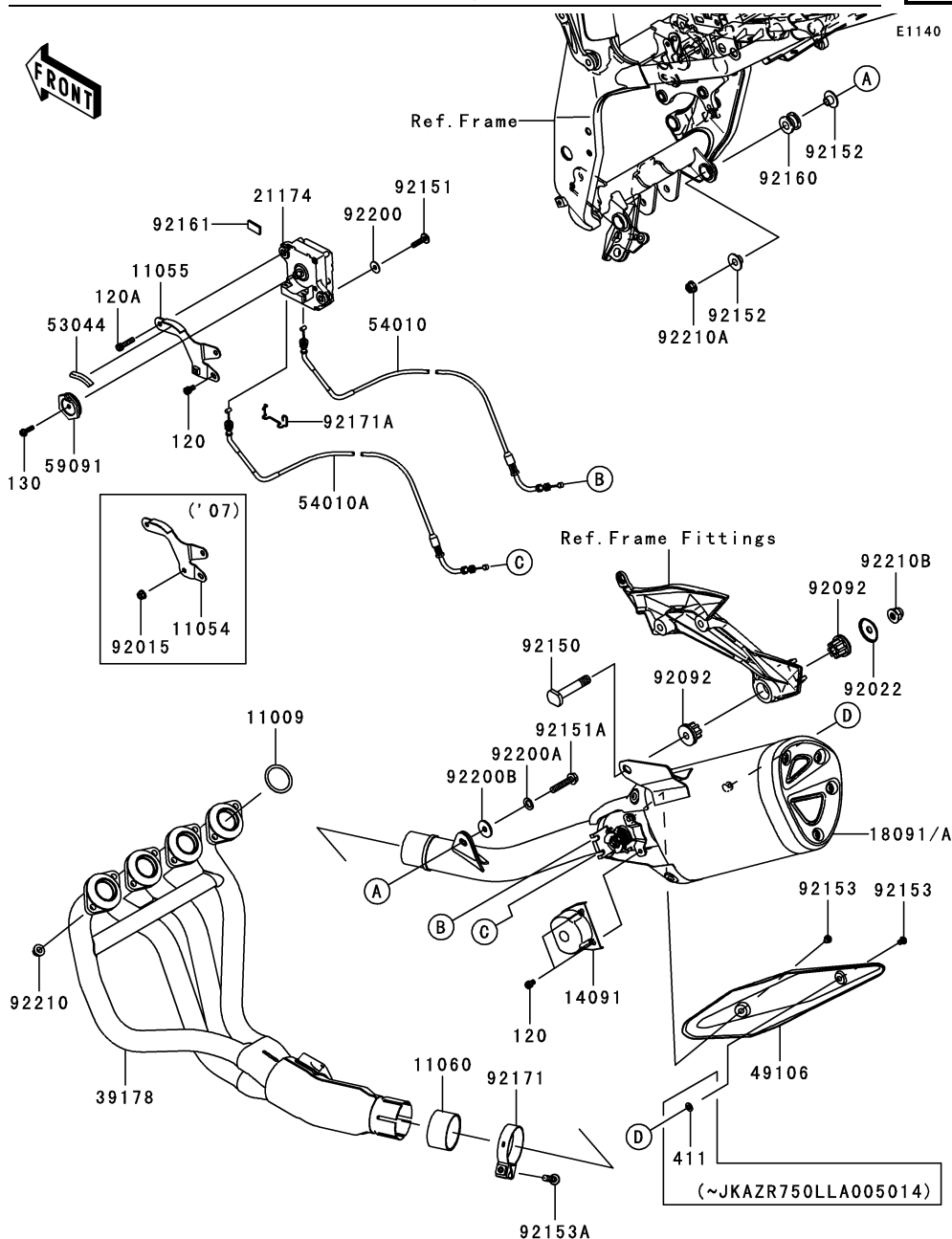

Ref. No.	Part No.	Description	Spec Code	Quantity-ZR750			
				'07	'08		
				L7F	L8F		
11009	11009-1856	GASKET,EXHAUST PIPE HOLDER	4	4			
11054	11054-1974	BRACKET,MOTOR	1				
11055	11055-0341	BRACKET,MOTOR		1			
11060	11060-1330	GASKET,EXHAUST PIPE HOLDER	1	1			
14091	14091-0712	COVER,PULLEY	1	1			
18091	18091-0474	BODY-COMP-MUFFLER	1				
	(JKAZR750LLA005014)						
18091A	18091-0483	BODY-COMP-MUFFLER	1	1			
	(JKAZR750LLA005015 -)						
21174	21174-0003	MOTOR-ELECTRIC	1	1			
39178	39178-0097	MANIFOLD-COMP-EXHAUST	1	1			
49106	49106-0069	COVER-MUFFLER	1	1			
53044	53044-0012	TRIM,L=40	1	1			
54010	54010-0083	CABLE,OPEN,WHITE NUT	1	1			
54010A	54010-0084	CABLE,CLOSE,BLACK NUT	1	1			
59091	59091-0007	PULLEY	1	1			
92015	92015-1367	NUT,FLANGED,6MM	1				
92022	92022-289	WASHER	1	1			
92092	92092-1087	BUSHING-RUBBER,MUFFLER	2	2			
92150	92150-1792	BOLT,10X55	1	1			
92151	92151-1611	BOLT,SOCKET,6X25	1	1			
92151A	92151-2130	BOLT,FLANGED,8X40	1	1			
92152	92152-0188	COLLAR	2	2			
92153	92153-0578	BOLT,6X8	2	2			
92153A	92153-0702	BOLT,8X45	1	1			
92160	92160-1116	DAMPER,MUFFLER MOUNT	1	1			
92161	92161-1170	DAMPER	1	1			
92171	92171-0133	CLAMP	1	1			
92171A	92171-0292	CLAMP	1	1			
92200	92200-0078	WASHER	1	1			
92200A	92200-0400	WASHER,10X18X1.2	1	1			
92200B	92200-3780	WASHER,8X26X2.3	1	1			
92210	92210-0121	NUT,8MM	8	8			
92210A	92210-0159	NUT,FLANGED,LOCK,8MM	1	1			
92210B	92210-1121	NUT,CAP,10MM	1	1			
120	120CB0610	BOLT-SOCKET,6X10	3	3			
120A	120W0625	BOLT-SOCKET,6X25	1	1			
130	130L0518	BOLT-FLANGED,5X18	1	1			
411	411S0600	WASHER-PLAIN,6MM	1				
	(JKAZR750LLA005014)						

This catalog covers:

'07~'08 ZR750 L7F/L8F Engine

GRID NO.

B-8

This grid covers:

Valve(s)

E1210

Ref. No.	Part No.	Description	Spec Code	Quantity-ZR750			
				'07	'08		
				L7F	L8F		
12004	12004-0005	VALVE-INTAKE	8	8			
12005	12005-0010	VALVE-EXHAUST	8	8			
12009	12009-0001	RETAINER-VALVE SPRING	16	16			
12011	12011-1052	COLLET	32	32			
12032	12032-0008	TAPPET	16	16			
16007	16007-1227	SEAT-SPRING	16	16			
49078	49078-0023	SPRING-ENGINE VALVE	16	16			
92049	92049-1308	SEAL-OIL, VALVE GUIDE	16	16			
92180	92180-0276	SHIM, T=3.225	AR	AR			
92180A	92180-0277	SHIM, T=3.275	AR	AR			
92180B	92180-0278	SHIM, T=3.325	AR	AR			
92180C	92180-1014	SHIM, T=2.50	16	16			
92180D	92180-1016	SHIM, T=2.55	AR	AR			
92180E	92180-1018	SHIM, T=2.60	AR	AR			
92180F	92180-1020	SHIM, T=2.65	AR	AR			
92180G	92180-1022	SHIM, T=2.70	AR	AR			
92180H	92180-1024	SHIM, T=2.75	AR	AR			
92180I	92180-1026	SHIM, T=2.80	AR	AR			
92180J	92180-1028	SHIM, T=2.85	AR	AR			
92180K	92180-1030	SHIM, T=2.90	AR	AR			
92180L	92180-1032	SHIM, T=2.95	AR	AR			
92180M	92180-1034	SHIM, T=3.00	AR	AR			
92180N	92180-1036	SHIM, T=3.05	AR	AR			
92180O	92180-1038	SHIM, T=3.10	AR	AR			
92180P	92180-1040	SHIM, T=3.15	AR	AR			
92180Q	92180-1042	SHIM, T=3.20	AR	AR			
92180R	92180-1044	SHIM, T=3.25	AR	AR			
92180S	92180-1046	SHIM, T=3.30	AR	AR			
92180T	92180-1048	SHIM, T=3.35	AR	AR			
92180U	92180-1050	SHIM, T=3.40	AR	AR			
92180V	92180-1052	SHIM, T=3.45	AR	AR			
92180W	92180-1054	SHIM, T=3.50	AR	AR			

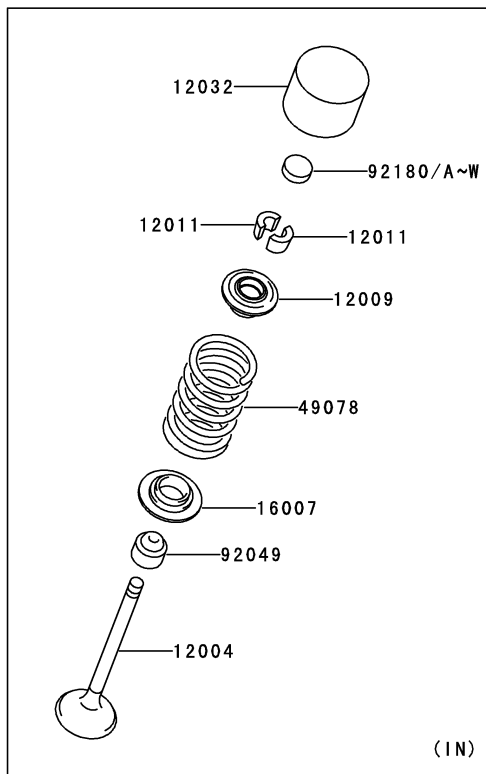
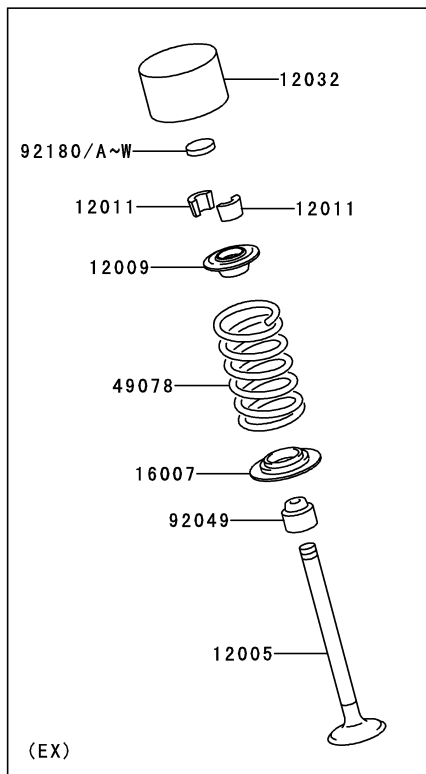

This catalog covers:

'07~'08 ZR750 L7F/L8F Engine

GRID NO.

B-9

This grid covers:

Camshaft(s)/Tensioner

E1230

Ref. No.	Part No.	Description	Spec Code	Quantity-ZR750			
				'07	'08		
				L7F	L8F		
12048	12048-0035	TENSIONER-ASSY		1	1		
12053	12053-1399	GUIDE-CHAIN,RR		1	1		
12053A	12053-1473	GUIDE-CHAIN,UPP		1	1		
12053B	12053-1478	GUIDE-CHAIN,FR		1	1		
13107	13107-0157	SHAFT,CHAIN GUIDE		1	1		
13107A	13107-1376	SHAFT		1	1		
49118	49118-0089	CAMSHAFT-COMP,INTAKE		1	1		
49118A	49118-0090	CAMSHAFT-COMP,EXHAUST		1	1		
92055	92055-086	RING-O,18.8X1.9		1	1		
92057	92057-1453	CHAIN,CAM,92RH2015-126M		1	1		
92066	92066-3780	PLUG		1	1		
92151	92151-1134	BOLT,6X30		1	1		
92151A	92151-1930	BOLT,FLANGED-SMALL,6X25		2	2		
92152	92152-1167	COLLAR		1	1		
670	670D1509	O RING,9MM		1	1		
670A	670D2014	O RING,14MM		1	1		

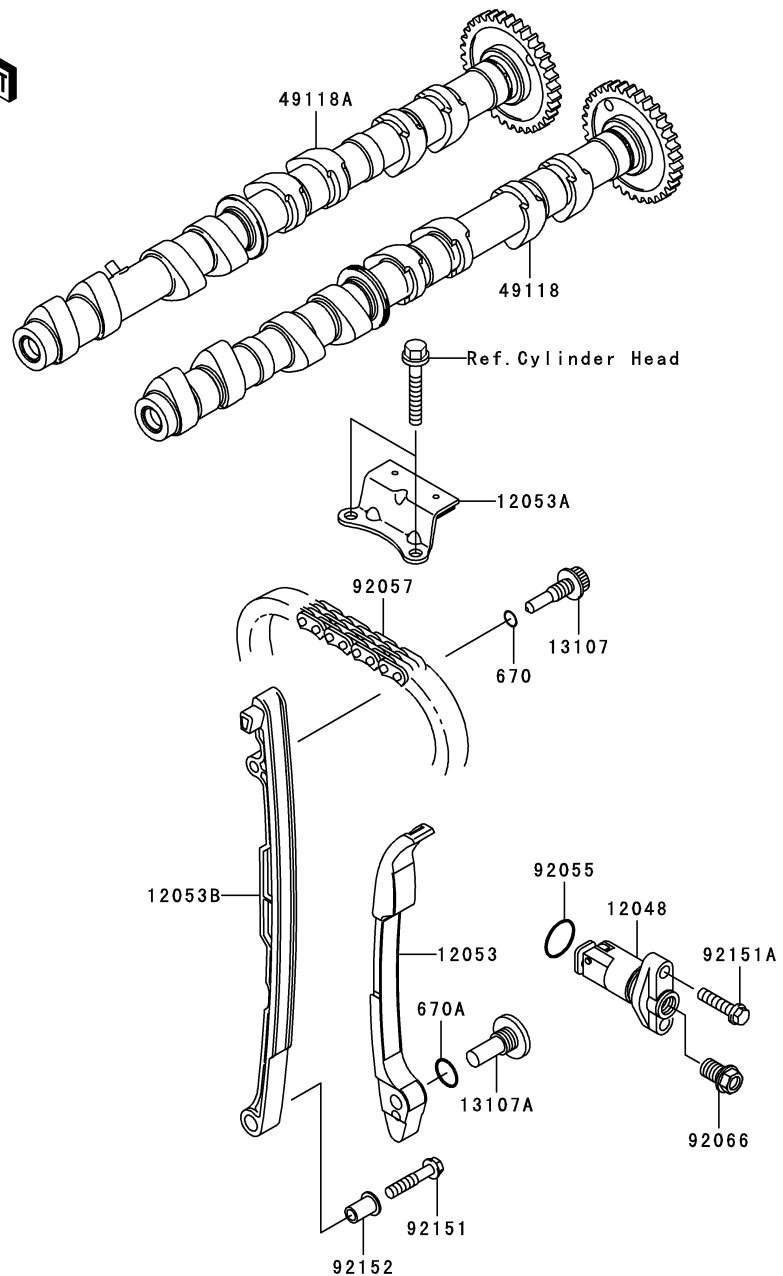

This catalog covers:

'07~'08 ZR750 L7F/L8F Engine

GRID NO.

B-10

This grid covers:

Crankshaft

E1321

Ref. No.	Part No.	Description	Spec Code	Quantity-ZR750			
				'07	'08		
				L7F	L8F		
13031	13031-0088	CRANKSHAFT-COMP		1	1		
13251	13251-1145-II	ROD-ASSY-CONNECTING,II		4	4		
92015	92015-1311	NUT,FLANGED,8MM		8	8		
92028	92028-1827	BUSHING,CRANK,BLUE		6	6		
92028A	92028-1828	BUSHING,CRANK,BLACK		AR	AR		
92028B	92028-1829	BUSHING,CRANK,BROWN		AR	AR		
92028C	92028-1866	BUSHING,CRANK,BLUE		4	4		
92028D	92028-1867	BUSHING,CRANK,BLACK		AR	AR		
92028E	92028-1868	BUSHING,CRANK,BROWN		AR	AR		
92139	92139-1108	BUSHING,CONNECTING ROD,BLUE		8	8		
92139A	92139-1109	BUSHING,CONNECTING ROD,BLACK		AR	AR		
92139B	92139-1110	BUSHING,CONNECTING ROD,BROWN		AR	AR		
92150	92150-1216	BOLT,CONNECTING ROD,8MM		8	8		

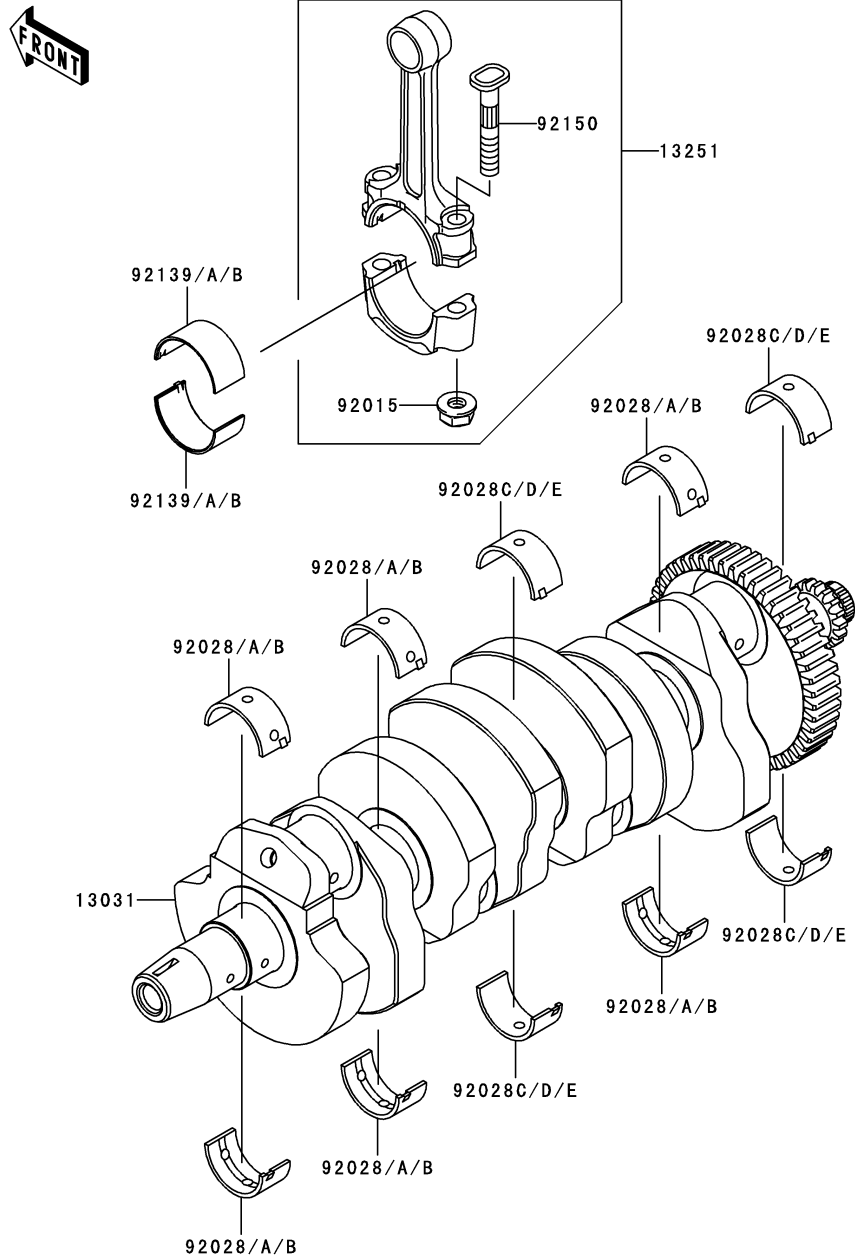

This catalog covers:

'07~'08 ZR750 L7F/L8F Engine

GRID NO.

B-11

This grid covers:

Clutch

E1350

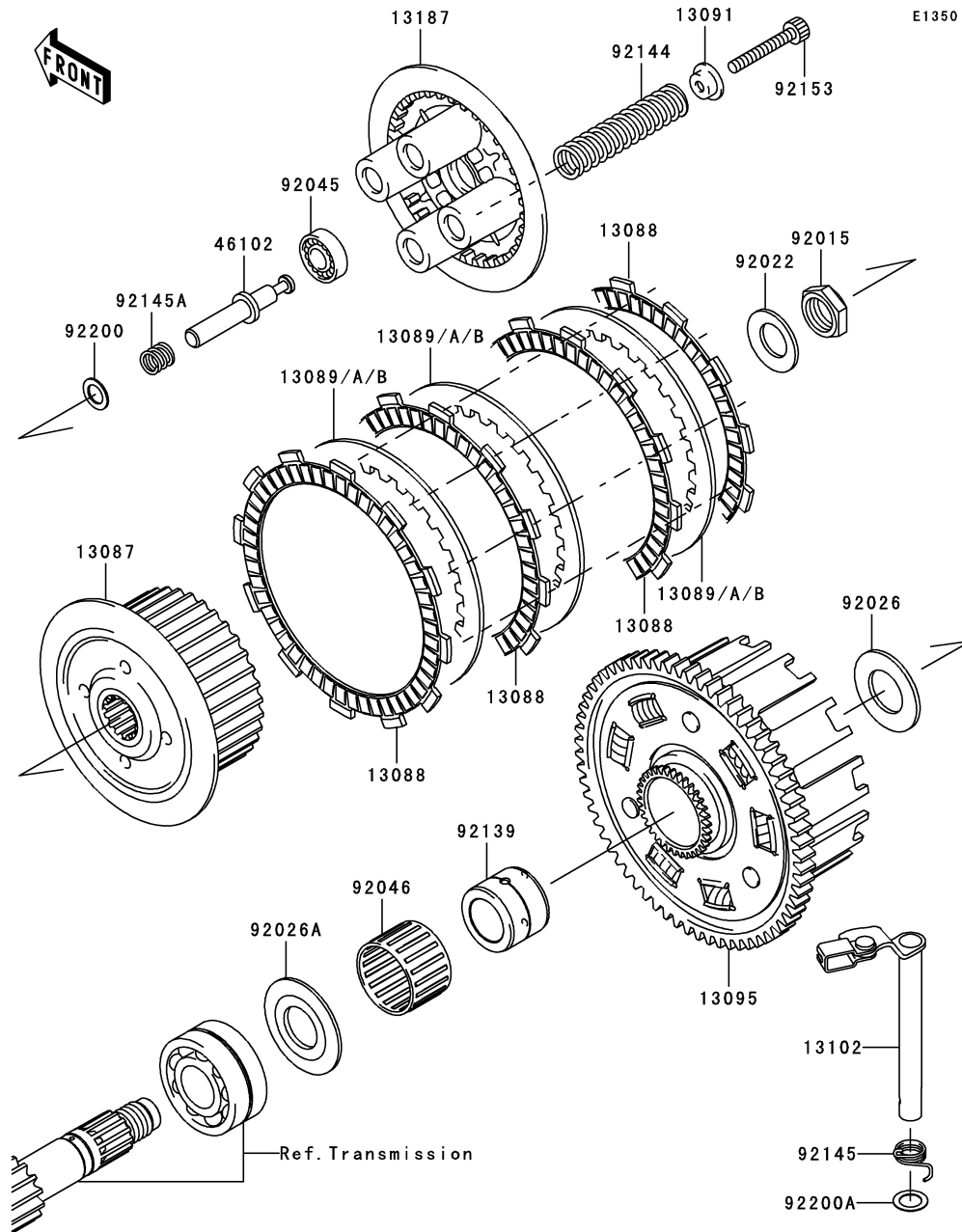

Ref. No.	Part No.	Description	Spec Code	Quantity-ZR750			
				'07	'08		
				L7F	L8F		
13087	13087-0006	HUB-CLUTCH	1	1			
13088	13088-1124	PLATE-FRICTION	9	9			
13089	13089-013	PLATE-CLUTCH,T=1.6	8	8			
13089A	13089-1073	PLATE-CLUTCH,T=2.0	AR	AR			
13089B	13089-1126	PLATE-CLUTCH,T=1.4	AR	AR			
13091	13091-1041	HOLDER,CLUTCH SPRING	4	4			
13095	13095-0070	HOUSING-COMP-CLUTCH	1	1			
13102	13102-0007	RELEASE-COMP-CLUTCH	1	1			
13187	13187-0003	PLATE-CLUTCH OPERATING	1	1			
46102	46102-0102	ROD	1	1			
92015	92015-1555	NUT,20MM	1	1			
92022	92022-1868	WASHER,20.3X36X3.7	1	1			
92026	92026-022	SPACER,25.5X47X2.5	1	1			
92026A	92026-1497	SPACER	1	1			
92045	92045-1235	BEARING-BALL,6001C3ML01	1	1			
92046	92046-1263	BEARING-NEEDLE,K38X43X28.8X	1	1			
92139	92139-0067	BUSHING,25X38X29.05	1	1			
92144	92144-1898	SPRING,CLUTCH,WHITE	4	4			
92145	92145-0066	SPRING,CLUTCH RELEASE	1	1			
92145A	92145-1159	SPRING,ROD	1	1			
92153	92153-0332	BOLT	4	4			
92200	92200-1423	WASHER,11.2X18X0.5	1	1			
92200A	92200-1487	WASHER,12X18.5X0.5	1	1			

This catalog covers:

'07~'08 ZR750 L7F/L8F Engine

GRID NO.

B-12

This grid covers:

Transmission

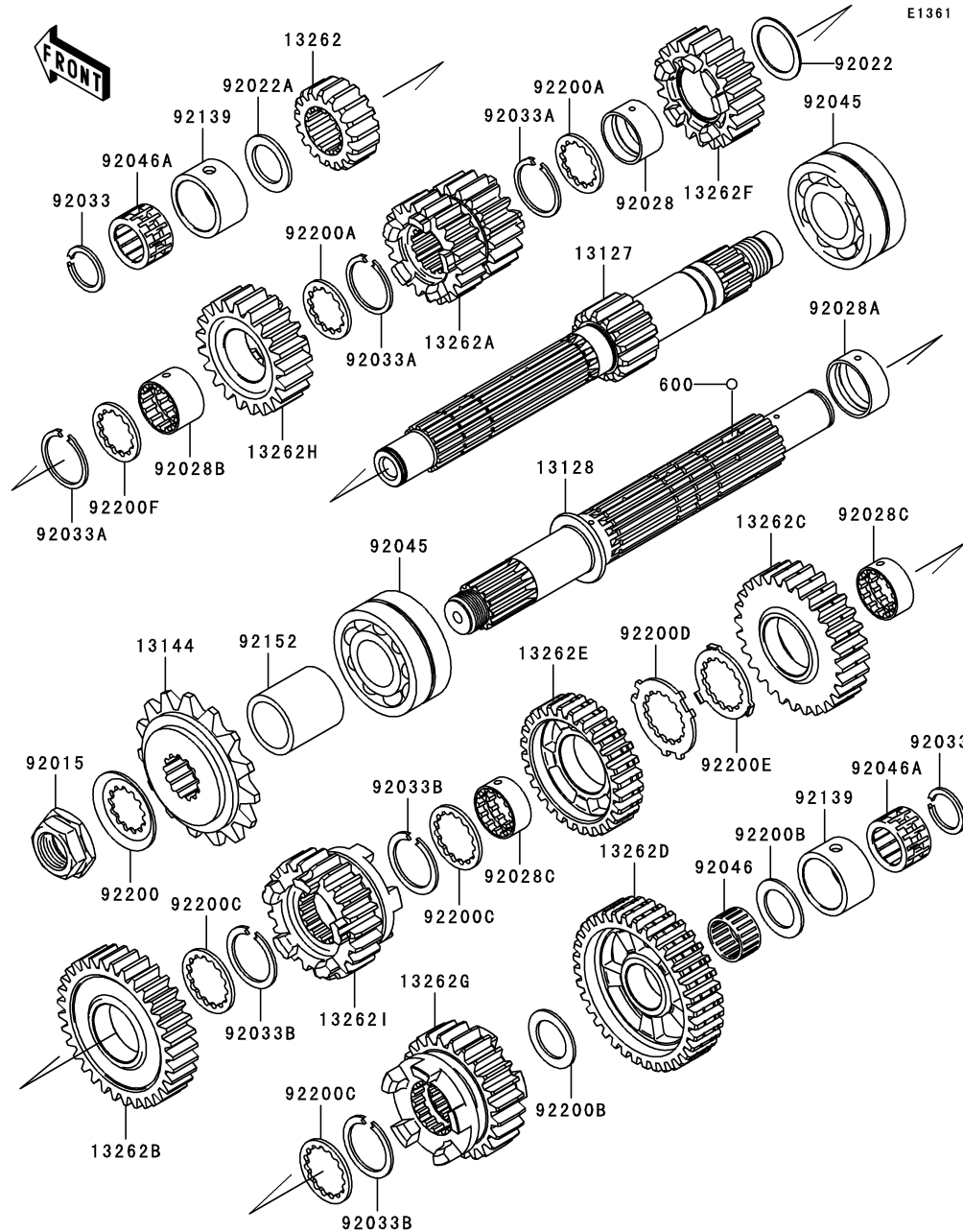

E1361

Ref. No.	Part No.	Description	Spec Code	Quantity-ZR750			
				'07	'08		
				L7F	L8F		
13127	13127-0008	SHAFT-TRANSMISSION INPUT,14T	1	1			
13128	13128-0005	SHAFT-TRANSMISSION OUTPUT	1	1			
13144	13144-0007	SPROCKET-OUTPUT,15T	1	1			
13262	13262-0064	GEAR,INPUT 2ND,17T	1	1			
13262A	13262-0065	GEAR,INPUT 3RD&4TH,18T&21T	1	1			
13262B	13262-0069	GEAR,OUTPUT 2ND,33T	1	1			
13262C	13262-0070	GEAR,OUTPUT 3RD,28T	1	1			
13262D	13262-0160	GEAR,OUTPUT LOW,36T	1	1			
13262E	13262-0162	GEAR,OUTPUT 4TH,28T	1	1			
13262F	13262-0163	GEAR,INPUT 5TH,20T	1	1			
13262G	13262-0164	GEAR,OUTPUT 5TH,24T	1	1			
13262H	13262-0550	GEAR,INPUT TOP,21T	1	1			
13262I	13262-0551	GEAR,OUTPUT TOP,23T	1	1			
92015	92015-1963	NUT,20MM	1	1			
92022	92022-1109	WASHER,25.3X33X1	1	1			
92022A	92022-112	WASHER,20.5X30X1,STEEL	1	1			
92028	92028-1735	BUSHING,INPUT 5TH GEAR	1	1			
92028A	92028-1739	BUSHING,OUTPUT,2ND	1	1			
92028B	92028-1915	BUSHING,INPUT TOP GEAR	1	1			
92028C	92028-1968	BUSHING,OUTPUT,3RD&4TH	2	2			
92033	92033-015	RING-SNAP,20MM	2	2			
92033A	92033-026	RING-SNAP,24MM	3	3			
92033B	92033-1249	RING-SNAP,T=1.5	3	3			
92045	92045-0003	BEARING-BALL,DAC2557NSSH	2	2			
92046	92046-1219	BEARING-NEEDLE,K20X24X13	1	1			
92046A	92046-1303	BEARING-NEEDLE,PK20X27X17X3	2	2			
92139	92139-1090	BUSHING,27X34X18.6	2	2			
92152	92152-0177	COLLAR,SPROCKET	1	1			
92200	92200-1065	WASHER	1	1			
92200A	92200-1239	WASHER,25.2X31.0X1.5	2	2			
92200B	92200-1375	WASHER,20.5X31X1.5	2	2			
92200C	92200-1457	WASHER,T=2.0	3	3			
92200D	92200-1522	WASHER,25.8X40.5X1.5	1	1			
92200E	92200-1523	WASHER,25.2X37.0X1.0	1	1			
92200F	92200-1524	WASHER,INPUT	1	1			
600	600A0500	BALL-STEEL,5/32"	3	3			

This catalog covers:

'07~'08 ZR750 L7F/L8F Engine

GRID NO.

B-13

This grid covers:

Gear Change Drum/Shift Fork(s)

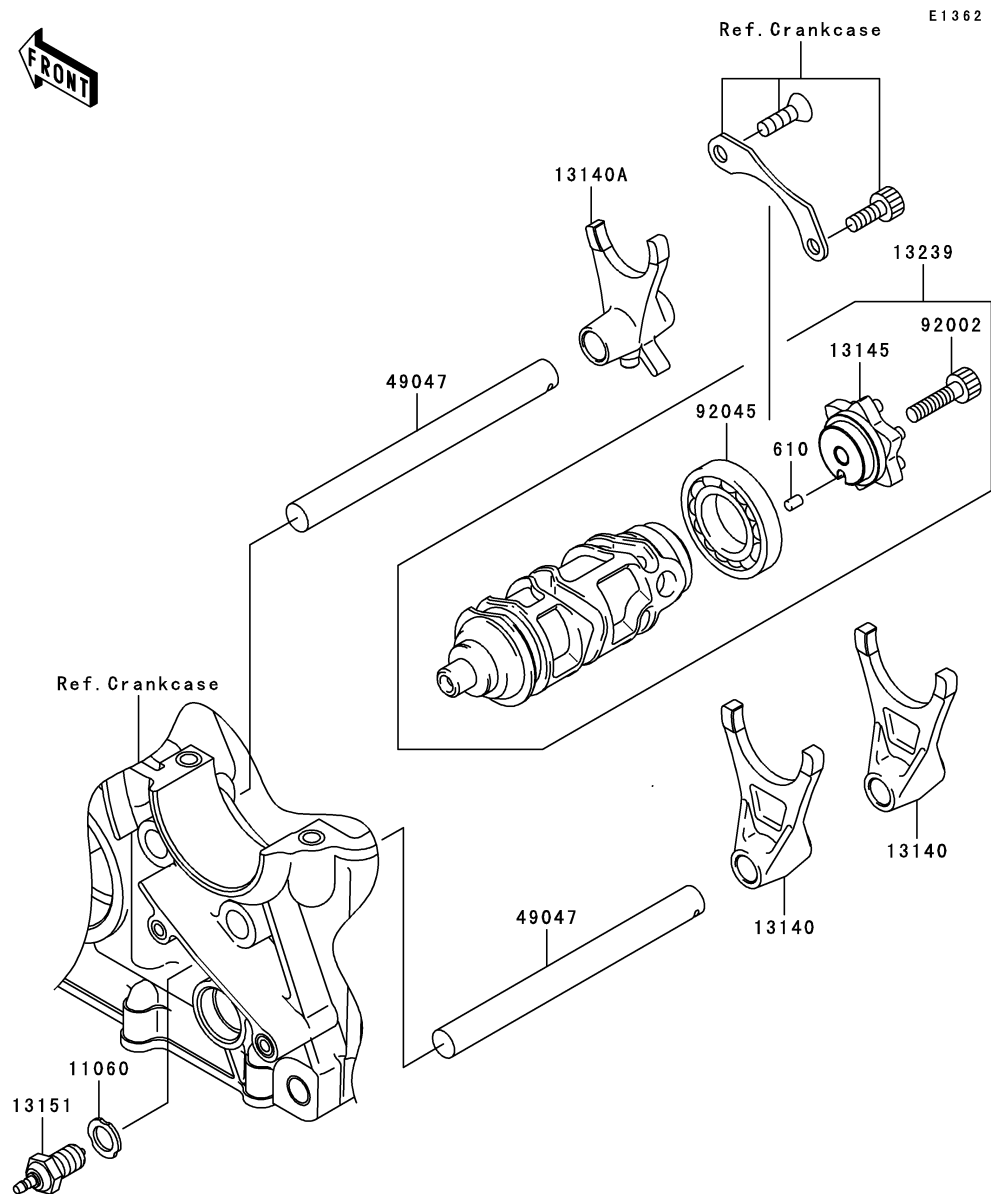

Ref. No.	Part No.	Description	Quantity-ZR750			
			'07	'08		
			L7F	L8F		
11060	11060-1676	GASKET,10.5X16X1.5	1	1		
13140	13140-1266	FORK-SHIFT,OUTPUT	2	2		
13140A	13140-1267	FORK-SHIFT,INPUT	1	1		
13145	13145-0032	CAM-CHANGE DRUM	1	1		
13151	13151-1085	SWITCH-COMP	1	1		
13239	13239-0026	DRUM-ASSY-CHANGE	1	1		
49047	49047-0010	ROD-SHIFT	2	2		
92002	92002-1696	BOLT,SOCKET,6X25	1	1		
92045	92045-1045	BEARING-BALL,16005(NTN)	1	1		
610	610A0406	ROLLER,4X6	1	1		

This catalog covers:

'07~'08 ZR750 L7F/L8F Engine

GRID NO.

B-14

This grid covers:

Gear Change Mechanism



E1370

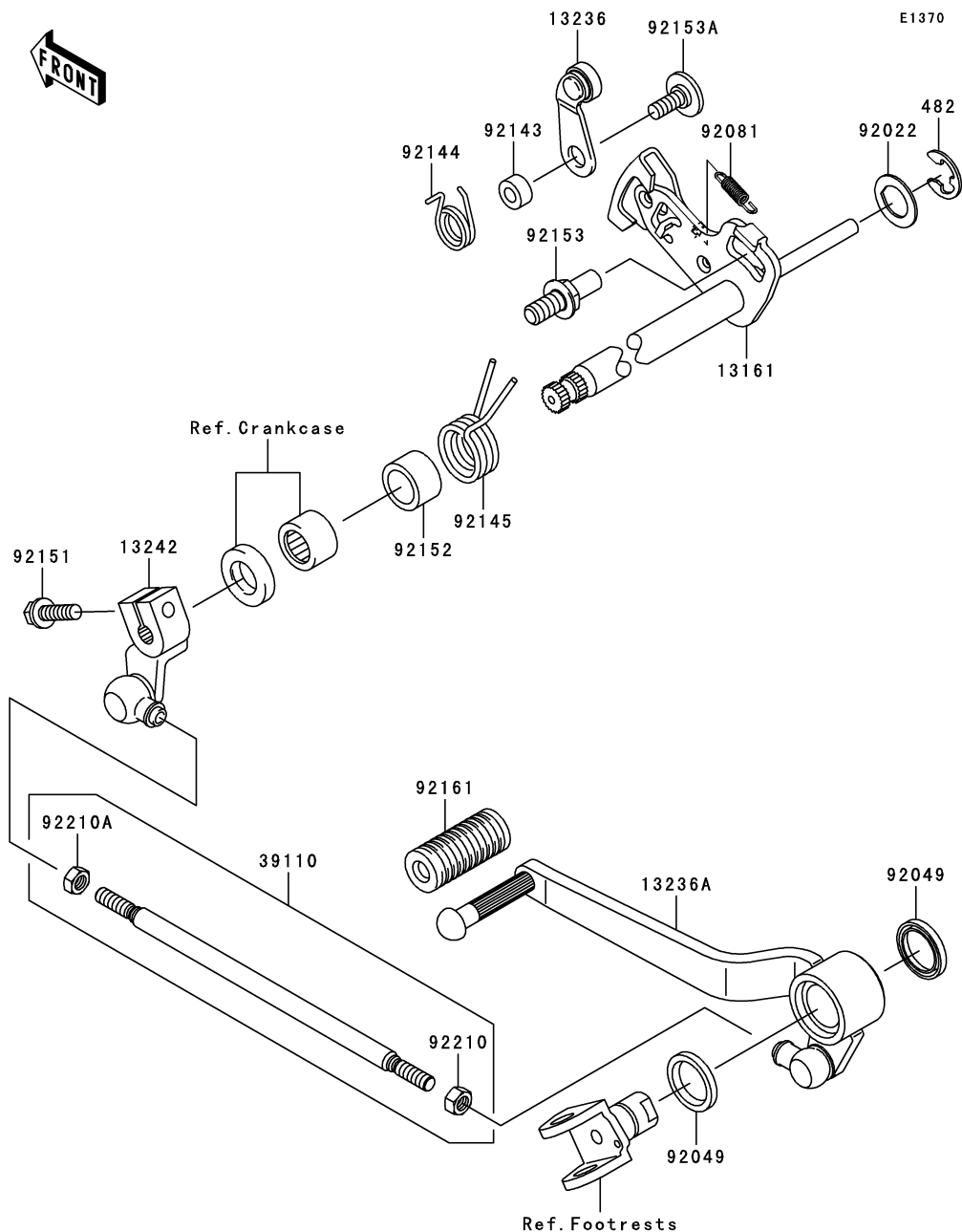

Ref. No.	Part No.	Description	Quantity-ZR750			
			'07	'08		
			L7F	L8F		
13161	13161-0057	LEVER-COMP-CHANGE SHAFT	1	1		
13236	13236-0106	LEVER-COMP,POSITION	1	1		
13236A	13236-0142	LEVER-COMP,CHANGE PEDAL	1	1		
13242	13242-1395	LEVER-ASSY-CHANGE	1	1		
39110	39110-0021	ROD-ASSY-TIE	1	1		
92022	92022-1628	WASHER,CHANGE SHAFT	1	1		
92049	92049-1492	SEAL-OIL	2	2		
92081	92081-1708	SPRING,PAWL RETURN	1	1		
92143	92143-1595	COLLAR	1	1		
92144	92144-1523	SPRING,GEAR POSITION	1	1		
92145	92145-1122	SPRING	1	1		
92151	92151-1226	BOLT,FLANGED,6X20	1	1		
92152	92152-1383	COLLAR,14.2X19.9X12.0	1	1		
92153	92153-0421	BOLT,RETURN SPRING	1	1		
92153A	92153-1505	BOLT,6X20	1	1		
92161	92161-1300	DAMPER,CHANGE PEDAL	1	1		
92210	92210-1100	NUT,6MM	1	1		
92210A	92210-1101	NUT,LEFT HANDED,6MM	1	1		
482	482J0200	CIRCLIP-TYPE-E,12MM	1	1		

This catalog covers:

'07~'08 ZR750 L7F/L8F Engine

GRID NO.

C-3

This grid covers:

Crankcase

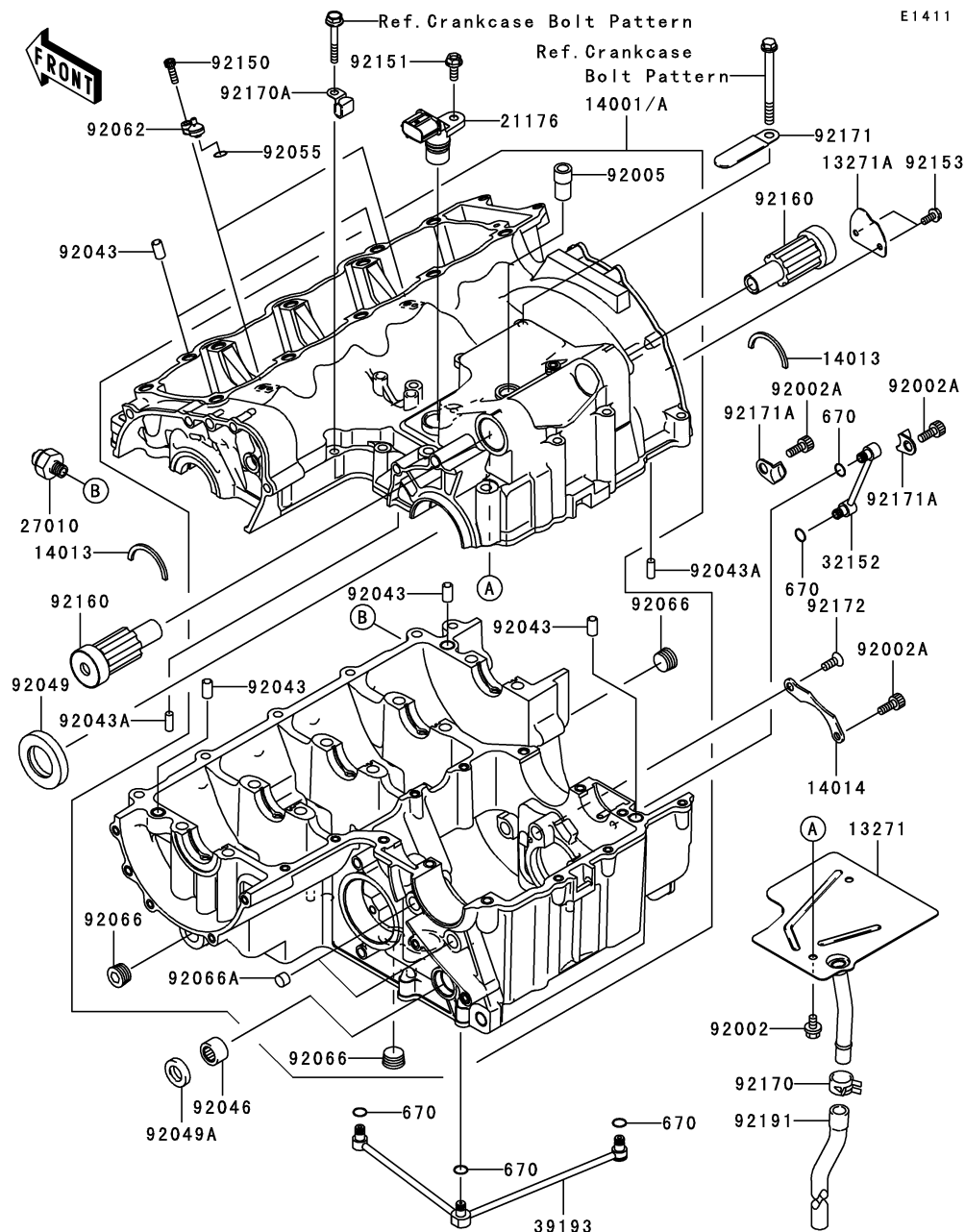

E1411

Ref. No.	Part No.	Description	Quantity-ZR750			
			'07	'08		
			L7F	L8F		
13271	13271-0747	PLATE,BREATHER	1	1		
13271A	13271-0748	PLATE,BREATHER SIDE	1	1		
14001	14001-0117	SET-CRANKCASE	1			
14001A	14001-0131	SET-CRANKCASE		1		
14013	14013-1051	RING-POSITION	2	2		
14014	14014-0027	PLATE-POSITION	1	1		
21176	21176-0054	SENSOR,SPEED	1	1		
27010	27010-1313	SWITCH,OIL PRESSURE	1	1		
32152	32152-1545	PIPE,RH,L=76.8	1	1		
39193	39193-0014	PIPE-OIL	1	1		
92002	92002-1449	BOLT,6X10	2	2		
92002A	92002-1778	BOLT,SOCKET,6X16	3	3		
92005	92005-1238	FITTING,BREATHER	1	1		
92043	92043-1037	PIN,DOWEL,10X14	5	5		
92043A	92043-1690	PIN,6X16	2	2		
92046	92046-037	BEARING-NEEDLE,7E-HK1412	1	1		
92049	92049-1474	SEAL-OIL,TC32578	1	1		
92049A	92049-1520	SEAL-OIL,TC14245	1	1		
92055	92055-1343	RING-O,5.5X1.5	2	2		
92062	92062-1092	NOZZLE,OIL JET	2	2		
92066	92066-0003	PLUG,PT3/8X10	3	3		
92066A	92066-1110	PLUG	2	2		
92150	92150-1019	BOLT,SOCKET,5X20	2	2		
92151	92151-1774	BOLT,FLANGED,6X16	1	1		
92153	92153-0753	BOLT,FLANGED,5X12	2	2		
92160	92160-1868	DAMPER	2	2		
92170	92170-1118	CLAMP	1	1		
92170A	92170-1577	CLAMP	1	1		
92171	92171-0092	CLAMP	1	1		
92171A	92171-0302	CLAMP,OIL PIPE	2	2		
92172	92172-0090	SCREW,6X16	1	1		
92191	92191-1776	TUBE,BREATHER	1	1		
670	670D1505	O RING	5	5		

This catalog covers:

'07~'08 ZR750 L7F/L8F Engine

GRID NO.

C-4

This grid covers:

Crankcase Bolt Pattern

E1412

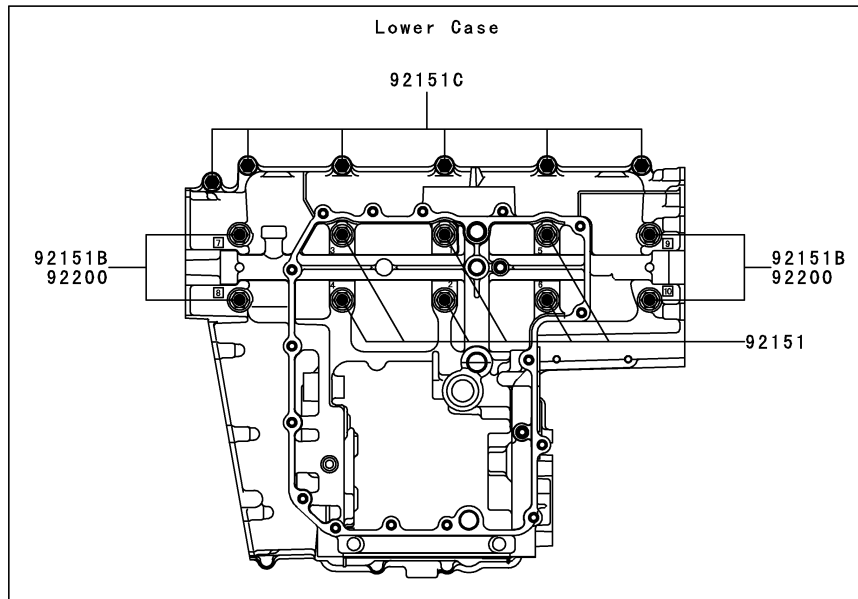
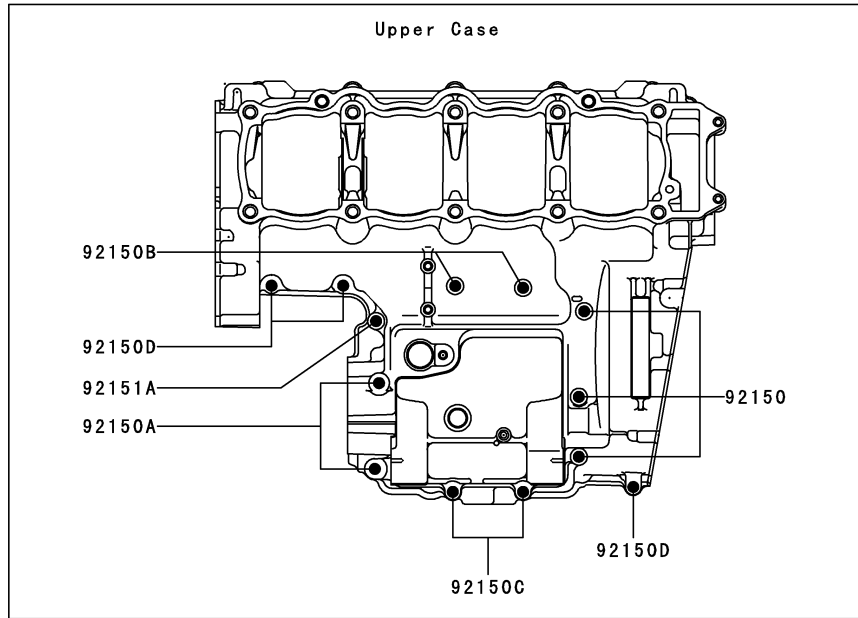

Ref. No.	Part No.	Description	Quantity-ZR750			
			'07	'08		
			L7F	L8F		
92150	92150-1251	BOLT,FLANGED,7X85	3	3		
92150A	92150-1483	BOLT,8X70	2	2		
92150B	92150-1548	BOLT,6X60	2	2		
92150C	92150-1622	BOLT,6X90	2	2		
92150D	92150-1794	BOLT,6X40	3	3		
92151	92151-1222	BOLT,9X81	6	6		
92151A	92151-1223	BOLT,FLANGED,7X50	1	1		
92151B	92151-1378	BOLT,FLANGED,9X95	4	4		
92151C	92151-1539	BOLT,FLANGED,7X45	6	6		
92200	92200-0115	WASHER,9.2X19X23	4	4		

This catalog covers:

'07~'08 ZR750 L7F/L8F Engine

GRID NO.

C-5

This grid covers:

Engine Cover(s)

E1431

Ref. No.	Part No.	Description	Spec Code	Quantity-ZR750			
				'07	'08		
				L7F	L8F		
11061	11061-0294	GASKET,GENERATOR COVER		1	1		
11061A	11061-1166	GASKET,CLUTCH COVER		1	1		
13271	13271-1997	PLATE		1	1		
14026	14026-0053	COVER-CHAIN		1			
14026A	14026-0060	COVER-CHAIN			1		
14031	14031-0060	COVER-GENERATOR		1			
14031A	14031-0092	COVER-GENERATOR			1		
14032	14032-0106	COVER-CLUTCH		1			
14032A	14032-0113	COVER-CLUTCH			1		
14091	14091-0657	COVER,PULSE		1			
14091A	14091-0937	COVER,PULSE			1		
16115	16115-1009	CAP-OIL FILLER		1	1		
52005	52005-1120	GAUGE		1	1		
92002	92002-1449	BOLT,6X10		3	3		
92002A	92002-1796	BOLT,SOCKET,6X12		1	1		
92042	92042-007	PIN,DOWEL,6.3X8X14		2	2		
92043	92043-1263	PIN,6.2X8X14		2	2		
92046	92046-1010	BEARING-NEEDLE,HK1210		2	2		
92049	92049-1475	SEAL-OIL,CLUTCH RELEASE		1	1		
92055	92055-049	RING-O,31.7X2.4		1	1		
92055A	92055-1570	RING-O,PULSE COVER		1	1		
92151	92151-1134	BOLT,6X30		8	8		
92151A	92151-1135	BOLT,6X35		4	4		
92153	92153-1574	BOLT-FLANGED,6X30		15	15		
92161	92161-0492	DAMPER		1	1		
92170	92170-1577	CLAMP		2	2		
92171	92171-0067	CLAMP		1	1		
92171A	92171-0708	CLAMP		1	1		
551	551A0814	PIN-DOWEL,8X14		2	2		

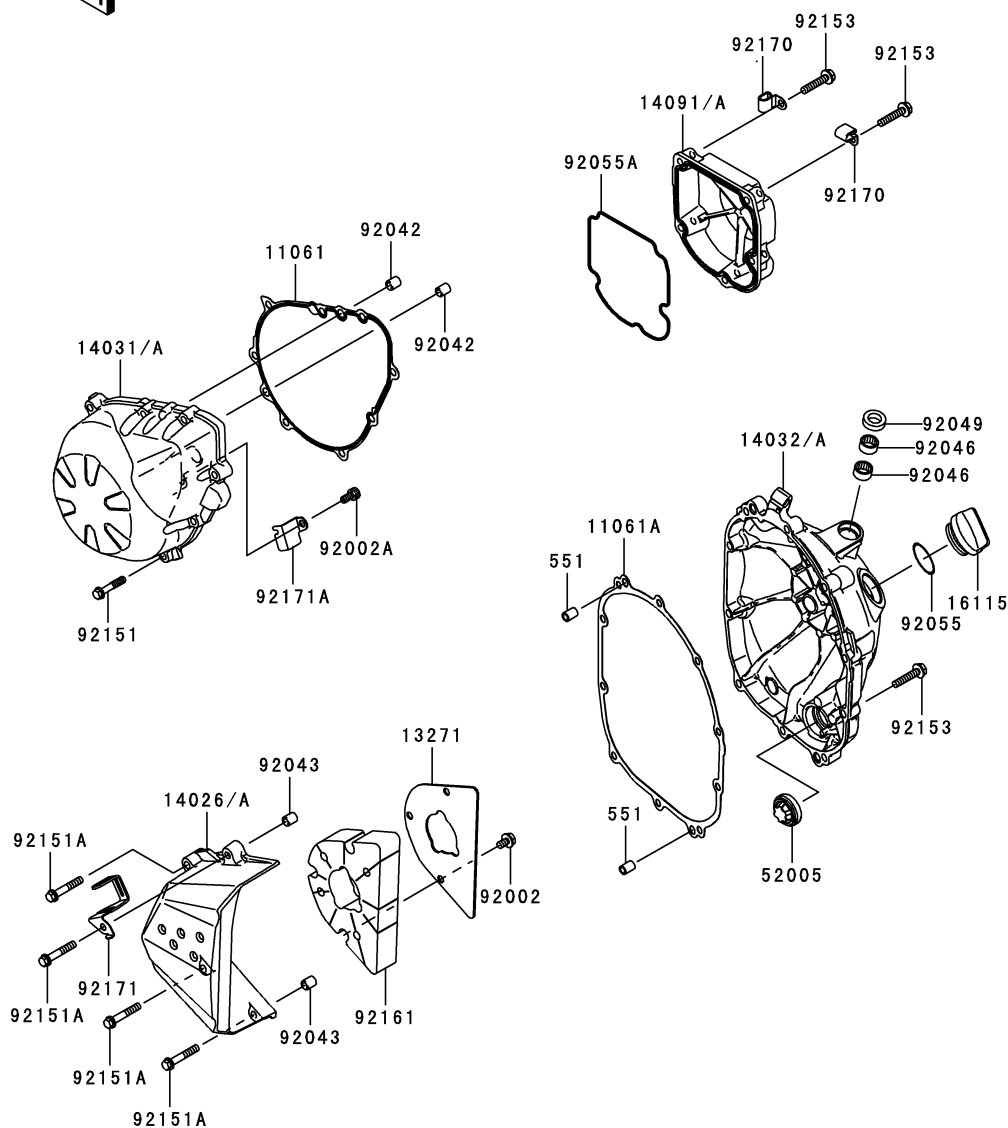

This catalog covers:

'07~'08 ZR750 L7F/L8F Engine

GRID NO.

C-6

This grid covers:

Oil Pan

E1434

Ref. No.	Part No.	Description	Spec Code	Quantity-ZR750			
				'07	'08		
				L7F	L8F		
11061	11061-1167	GASKET,OIL PAN	1	1			
49034	49034-0025	PAN-OIL	1				
49034A	49034-0029	PAN-OIL		1			
92065	92065-097	GASKET,12X22X2	1	1			
92066	92066-1174	PLUG,OIL DRAIN,12X15	1	1			
92153	92153-1569	BOLT-FLANGED,6X25	16	16			
92170	92170-1577	CLAMP	1	1			
92171	92171-0926	CLAMP	1	1			
130	130J0616	BOLT-FLANGED,6X16	4	4			

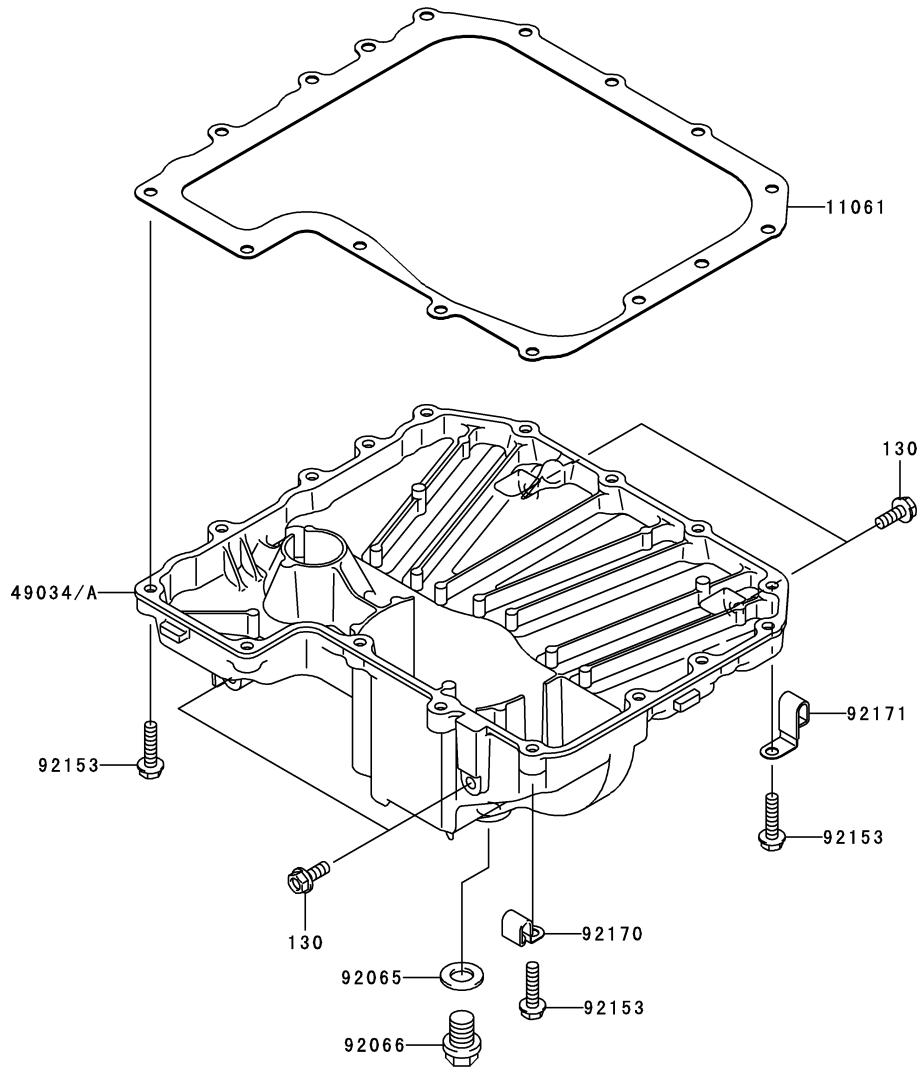

This catalog covers:

'07~'08 ZR750 L7F/L8F Engine

GRID NO.

C-7

This grid covers:

Throttle

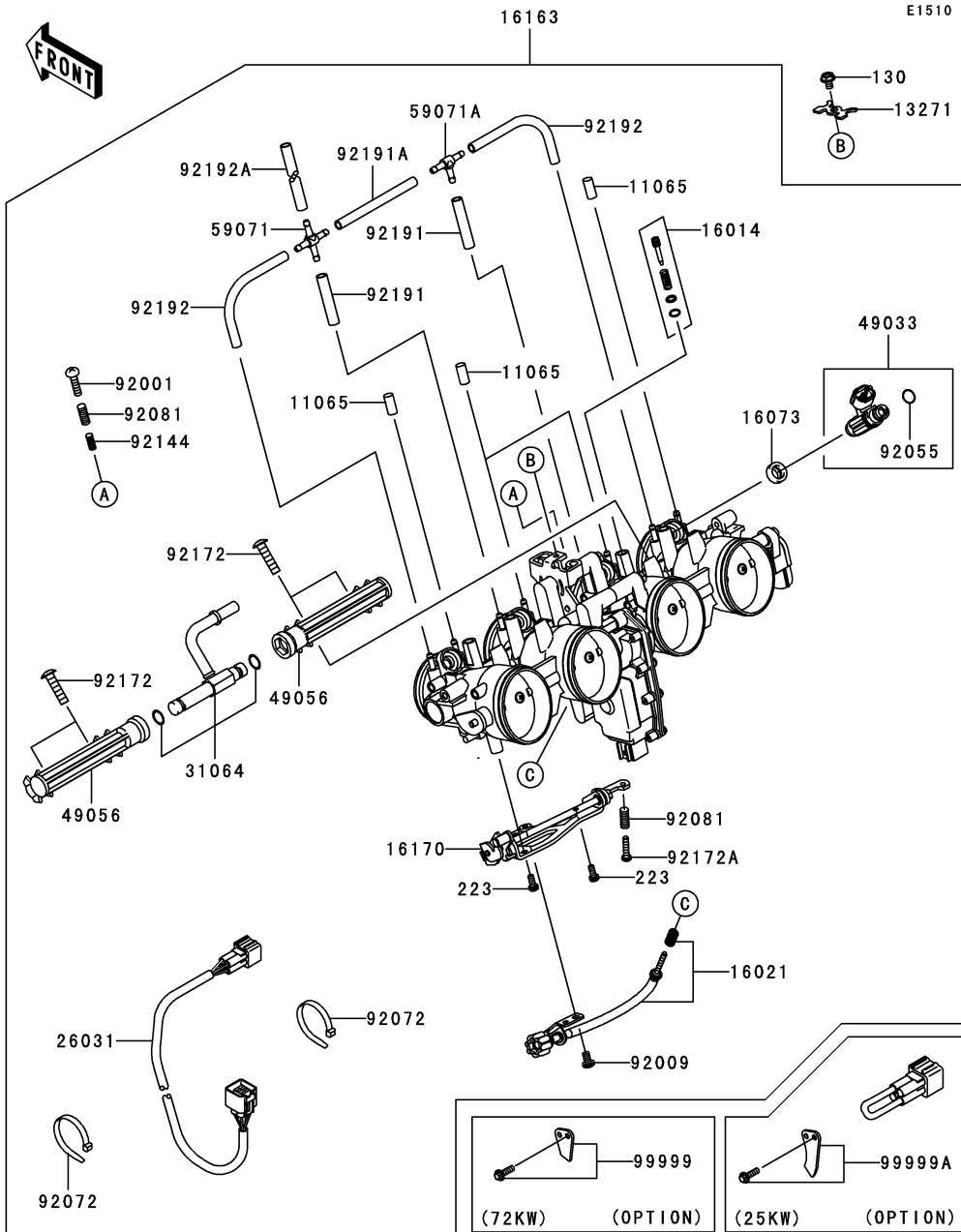

Ref. No.	Part No.	Description	Spec Code	Quantity-ZR750			
				'07	'08		
				L7F	L8F		
11065	11065-0018	CAP	4	4			
13271	13271-0056	PLATE	1	1			
16014	16014-0002	SCREW-PILOT AIR	4	4			
16021	16021-0017	SCREW-THROTTLE STOP	1	1			
16073	16073-3707	INSULATOR	4	4			
16163	16163-0081	THROTTLE-ASSY,TTK32	1	1			
16170	16170-0005	LINK-ASSY	1	1			
26031	26031-0313	HARNESS	1	1			
31064	31064-0101	PIPE-COMP,FUEL	1	1			
49033	49033-0013	NOZZLE-INJECTION	4	4			
49056	49056-0001	PIPE-INJECTION	2	2			
59071	59071-0014	JOINT,4WAY	1	1			
59071A	59071-3752	JOINT,3WAY,T	1	1			
92001	92001-1998	BOLT,THROTTLE ADJUST	1	1			
92009	92009-1502	SCREW,5X10	1	1			
92055	92055-1622	RING-O,INJECTION NOZZLE	4	4			
92072	92072-0012	BAND,SUB-HARNESS	2	2			
92081	92081-1620	SPRING	2	2			
92144	92144-1451	SPRING	1	1			
92172	92172-0064	SCREW,PIPE INJECTION	4	4			
92172A	92172-0065	SCREW,THROTTLE SYNCRO	1	1			
92191	92191-0025	TUBE,3X7X30	2	2			
92191A	92191-0036	TUBE,3X7X82	1	1			
92192	92192-0018	TUBE,3X7X95	2	2			
92192A	92192-0019	TUBE,3X7X170	1	1			
99999	99999-0111	KIT,.72KW	1	1			
	(OPTION)						
99999A	99999-0112	KIT,.25KW	1	1			
	(OPTION)						
130	130G0508	BOLT-FLANGED,5X8	1	1			
223	223D0410	SCREW-PAN-WS-CROS,4X10	2	2			

This catalog covers:

'07~'08 ZR750 L7F/L8F Engine

GRID NO.

C-8

This grid covers:

Fuel Pump

E1520

Ref. No.	Part No.	Description	Spec Code	Quantity-ZR750			
				'07	'08		
				L7F	L8F		
49040	49040-0018	PUMP-FUEL		1	1		
51044	51044-0042	TUBE-ASSY,FUEL		1	1		
92153	92153-1283	BOLT,FLANGED,6X12		5	5		
670	670E5075	O RING		1	1		

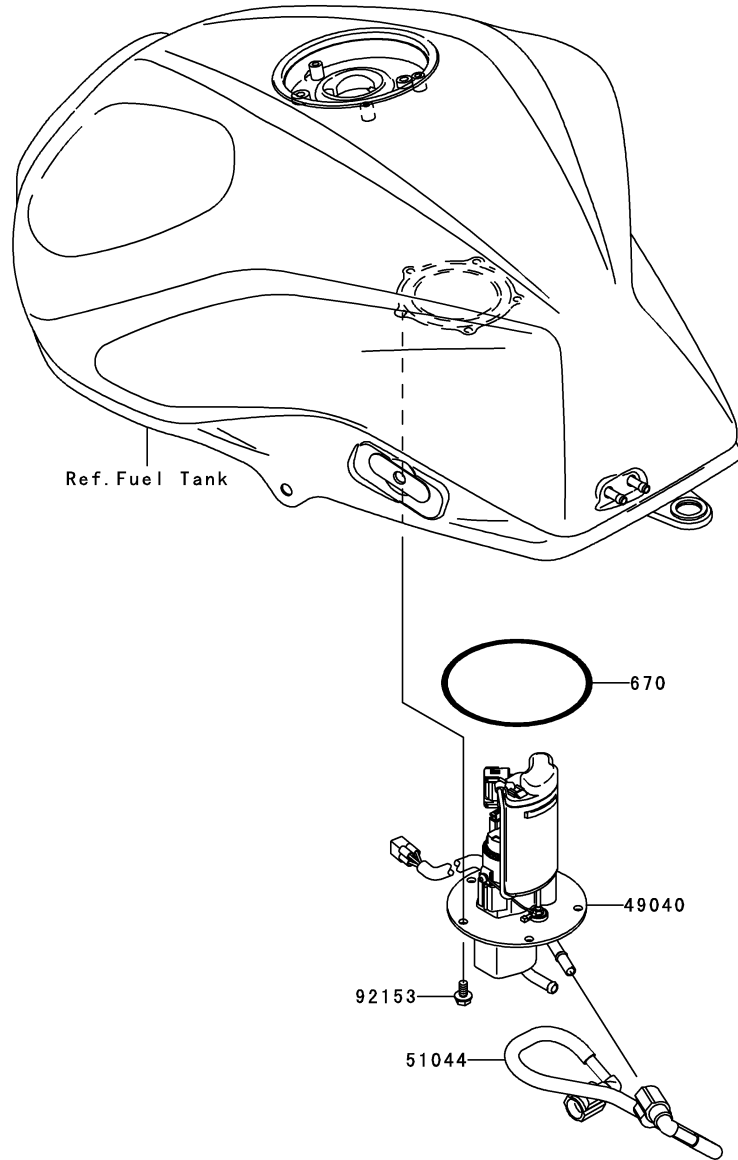

This catalog covers:

'07~'08 ZR750 L7F/L8F Engine

GRID NO.

C-9

This grid covers:

Fuel Injection

E1530

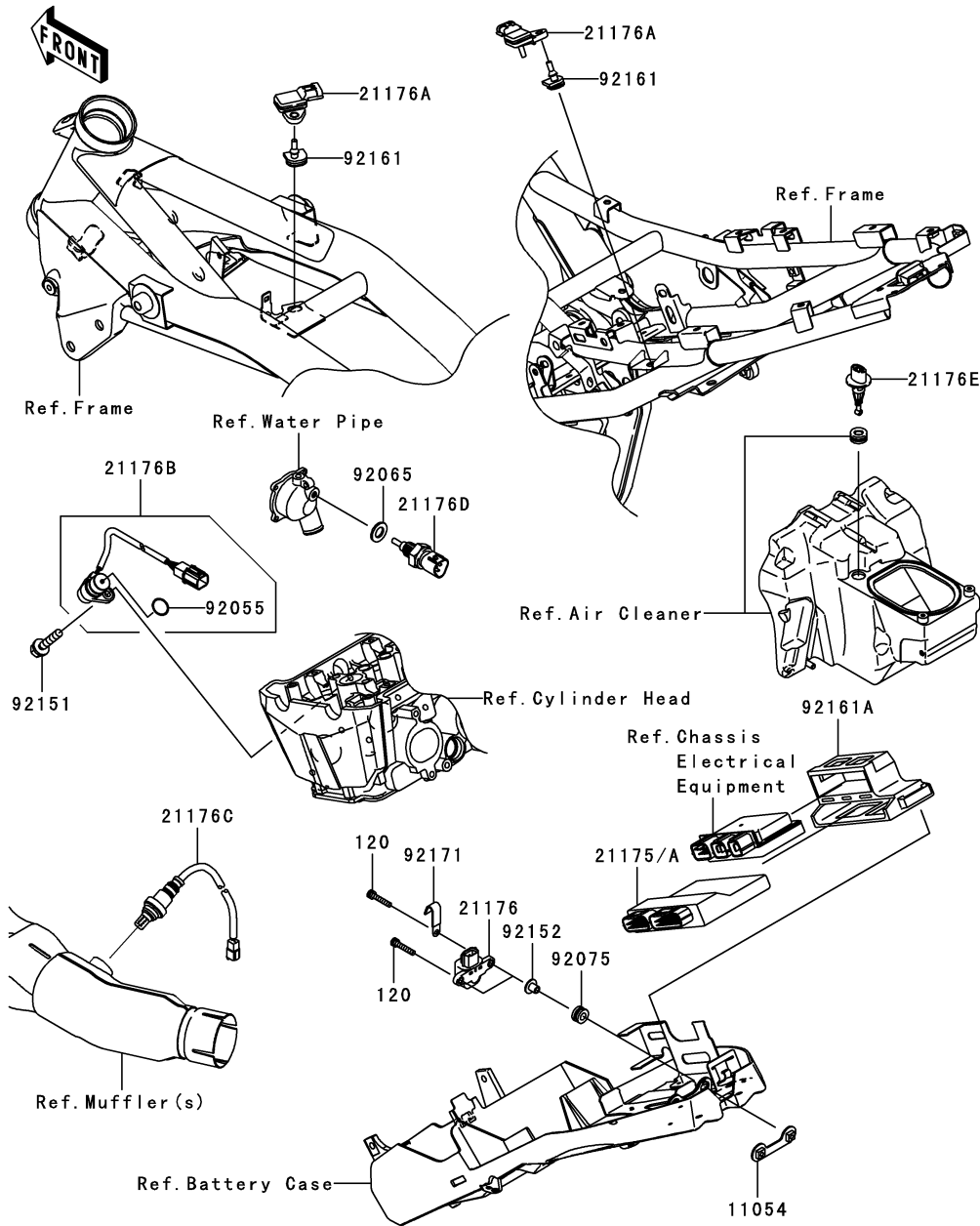

Ref. No.	Part No.	Description	Spec Code	Quantity-ZR750			
				'07	'08		
				L7F	L8F		
11054	11054-1892	BRACKET		1	1		
21175	21175-0098	CONTROL UNIT-ELECTRONIC		1			
21175A	21175-0173	CONTROL UNIT-ELECTRONIC			1		
21176	21176-0026	SENSOR,VEHICLE-DOWN		1	1		
21176A	21176-0058	SENSOR,PRESSURE		2	2		
21176B	21176-0064	SENSOR,CAM		1	1		
21176C	21176-0085	SENSOR,OXYGEN		1	1		
21176D	21176-1120	SENSOR,WATER TEMP		1	1		
21176E	21176-2106	SENSOR,AIR TEMP		1	1		
92055	92055-1639	RING-O		1	1		
92065	92065-097	GASKET,12X22X2		1	1		
92075	92075-1912	DAMPER		2	2		
92151	92151-1774	BOLT,FLANGED,6X16		1	1		
92152	92152-0134	COLLAR		2	2		
92161	92161-0041	DAMPER		2	2		
92161A	92161-0356	DAMPER		1	1		
92171	92171-1539	CLAMP		1	1		
120	120P0525	BOLT-SOCKET,5X25		2	2		

This catalog covers:

'07~'08 ZR750 L7F/L8F Engine

GRID NO.

C-10

This grid covers:

Oil Pump

E1710

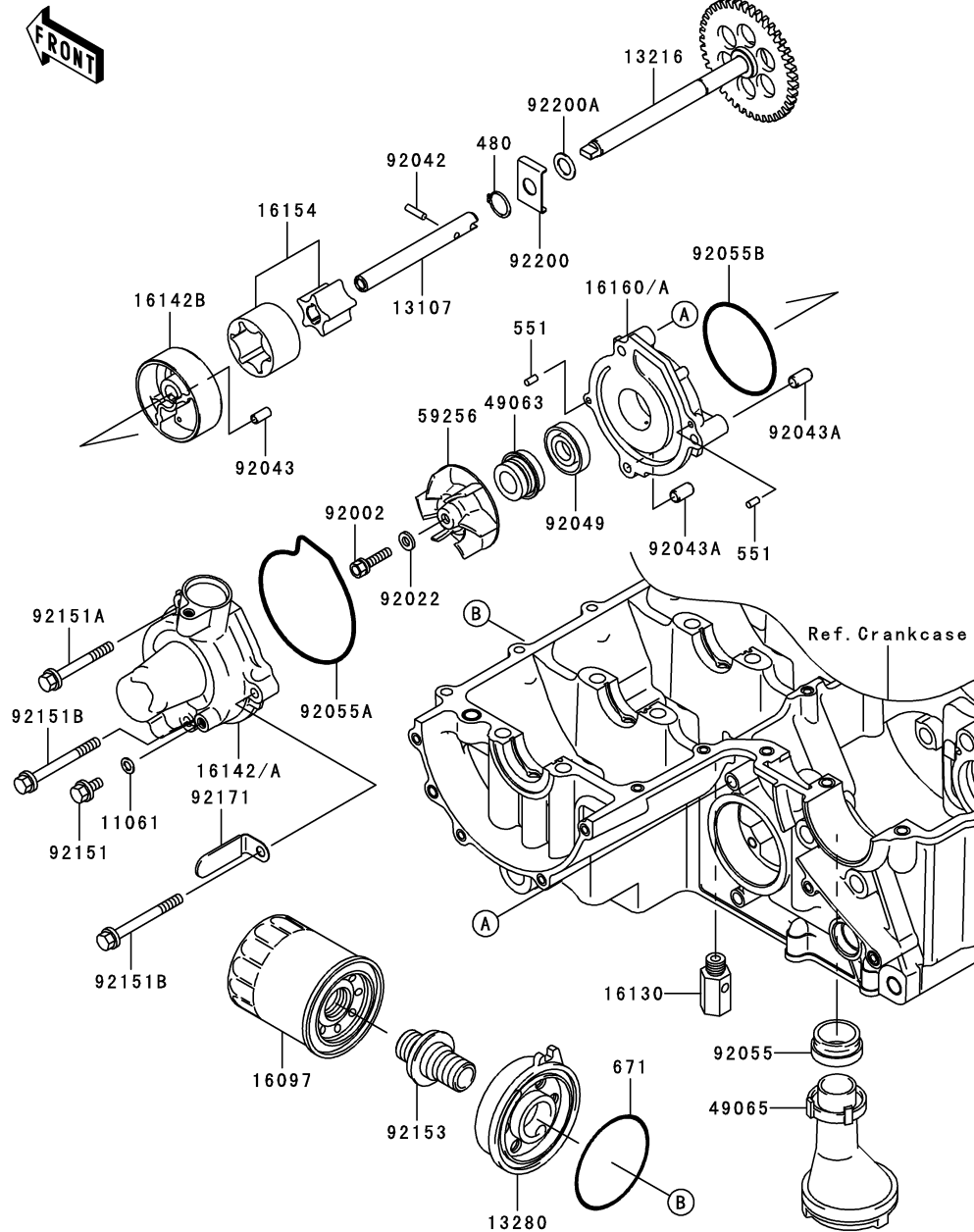

Ref. No.	Part No.	Description	Spec Code	Quantity-ZR750			
				'07	'08		
				L7F	L8F		
11061	11061-0107	GASKET	1	1			
13107	13107-0046	SHAFT,OIL PUMP	1	1			
13216	13216-0020	GEAR-COMPOIL PUMP,41T	1	1			
13280	13280-0022	HOLDER	1	1			
16097	16097-0004	FILTER-ASSY-OIL	1	1			
16130	16130-1058	VALVE-ASSY-RELIEF	1	1			
16142	16142-0037	COVER-PUMP	1				
16142A	16142-0054	COVER-PUMP		1			
16142B	16142-1146	COVER-PUMP,OIL	1	1			
16154	16154-0057	ROTOR-PUMP	1	1			
16160	16160-0136	BODY,OIL PUMP	1				
16160A	16160-0152	BODY,OIL PUMP		1			
49063	49063-1055	SEAL-MECHANICAL,WATER	1	1			
49065	49065-1078	FILTER-OIL	1	1			
59256	59256-1074	IMPELLER	1	1			
92002	92002-1154	BOLT,6X22	1	1			
92022	92022-077	WASHER,6.1X12X1	1	1			
92042	92042-030	PIN,DOWEL,4X13.8	1	1			
92043	92043-1262	PIN,4.2X6X12	1	1			
92043A	92043-1263	PIN,6.2X8X14	2	2			
92049	92049-1336	SEAL-OIL,SC 11 28.55 5	1	1			
92055	92055-1503	RING-O,OIL FILTER	1	1			
92055A	92055-1571	RING-O,WATER PUMP COVER	1	1			
92055B	92055-3018	RING-O,59.6X2.4	1	1			
92151	92151-1133	BOLT,6X12	1	1			
92151A	92151-1234	BOLT,6X50	1	1			
92151B	92151-1235	BOLT,6X60	2	2			
92153	92153-0424	BOLT	1	1			
92171	92171-1420	CLAMP	1	1			
92200	92200-0366	WASHER	1	1			
92200A	92200-1009	WASHER	1	1			
480	480J1100	CIRCLIP-TYPE-C,11MM	1	1			
551	551A0408	PIN-DOWEL,4X8	2	2			
671	671B2565	O RING,65MM	1	1			

This catalog covers:

'07~'08 ZR750 L7F/L8F Engine

GRID NO.

C-11

This grid covers:

Generator

E1810

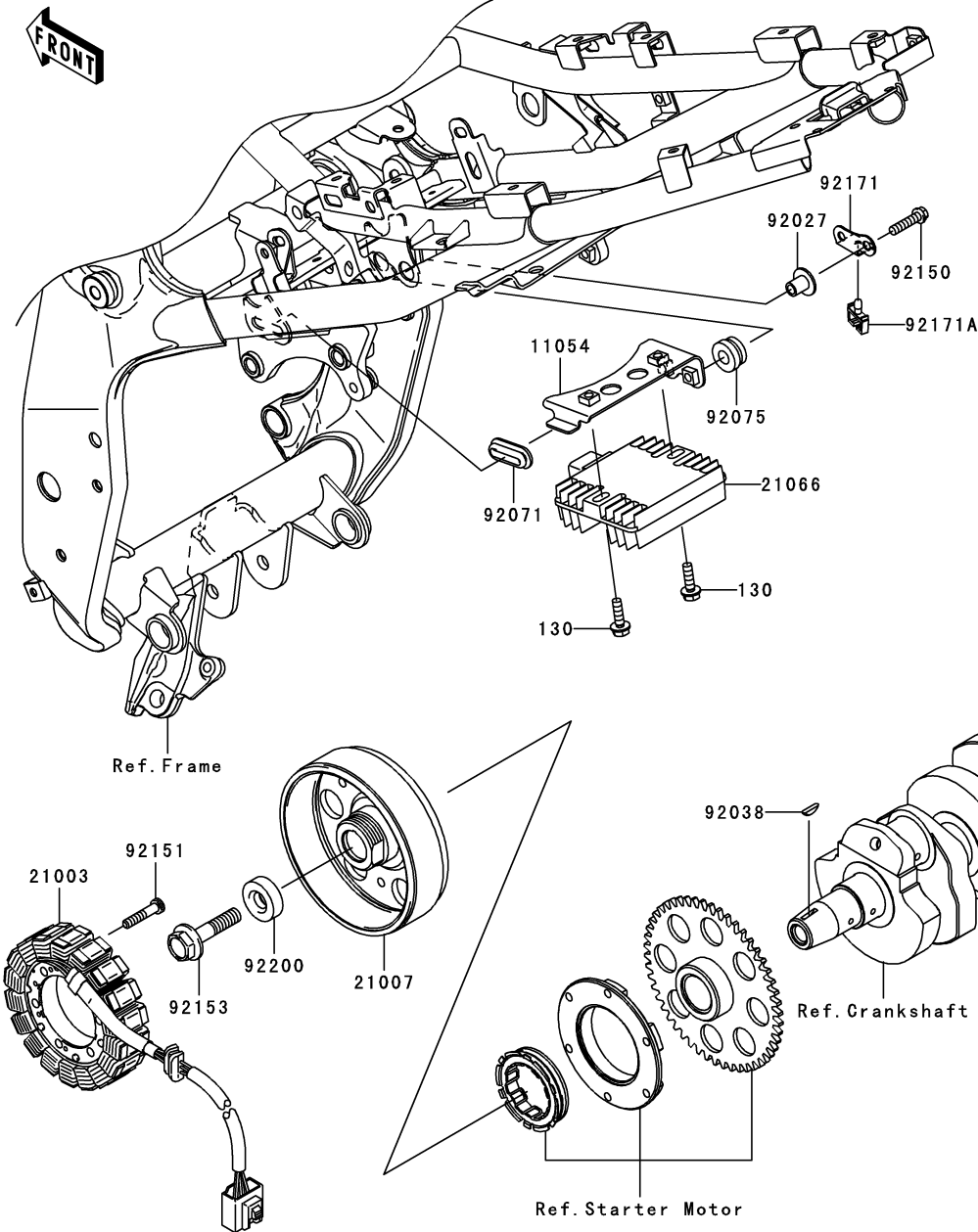

Ref. No.	Part No.	Description	Spec Code	Quantity-ZR750			
				'07	'08		
				L7F	L8F		
11054	11054-0875	BRACKET,REGULATOR	1	1			
21003	21003-0046	STATOR	1	1			
21007	21007-0021	ROTOR	1	1			
21066	21066-1127	REGULATOR-VOLTAGE	1	1			
92027	92027-1920	COLLAR,L=14.1	2	2			
92038	92038-1060	KEY	1	1			
92071	92071-1187	GROMMET	1	1			
92075	92075-1123	DAMPER,RUBBER	2	2			
92150	92150-1779	BOLT,FLANGED-SMALL,6X25	2	2			
92151	92151-1626	BOLT,6X30	4	4			
92153	92153-1855	BOLT,12X40	1	1			
92171	92171-0930	CLAMP	1	1			
92171A	92171-0931	CLAMP	1	1			
92200	92200-0369	WASHER,12X34X9	1	1			
130	130L0620	BOLT-FLANGED,6X20	2	2			

This catalog covers:

'07~'08 ZR750 L7F/L8F Engine

GRID NO.

C-12

This grid covers:

Ignition System

E1830

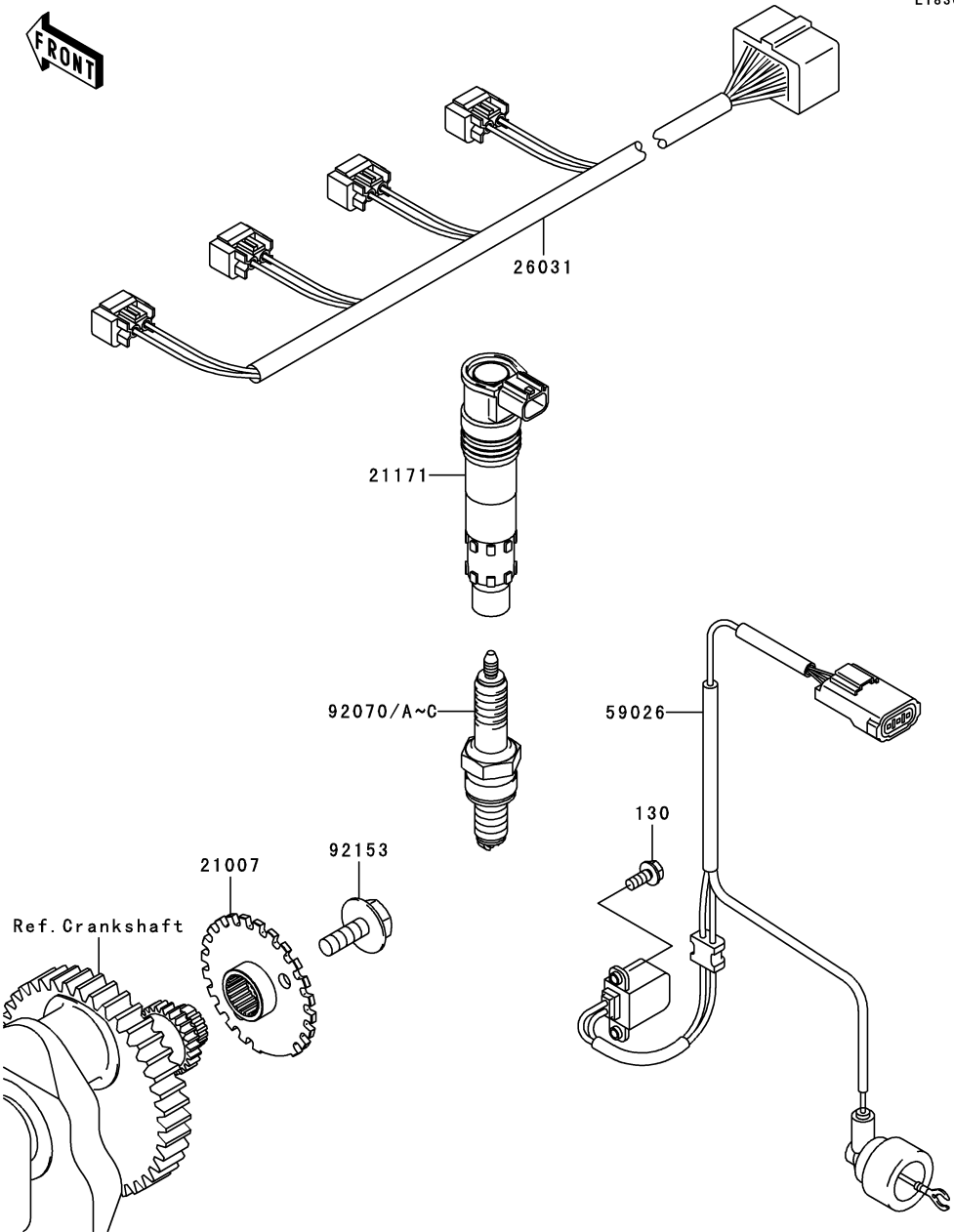

Ref. No.	Part No.	Description	Spec Code	Quantity-ZR750			
				'07	'08		
				L7F	L8F		
21007	21007-0081	ROTOR	1	1			
21171	21171-1286	COIL-ASSY-IGNITION	4	4			
26031	26031-0541	HARNESS,E/G SUB	1	1			
59026	59026-0014	COIL-PULSING	1	1			
92070		PLUG-SPARK,U27ETR(ND) (LOCAL PROCUREMENT ITEM)	4	4			
92070A		PLUG-SPARK,U24ETR(ND) (LOCAL PROCUREMENT ITEM) (OPTION)	4	4			
92070B	92070-1264	PLUG-SPARK,CR9EK(NGK)	4	4			
92070C	92070-1265	PLUG-SPARK,CR8EK(NGK) (OPTION)	4	4			
92153	92153-0549	BOLT,FLANGED,8X23	1	1			
130	130G0512	BOLT-FLANGED,5X12	2	2			

This catalog covers:

'07~'08 ZR750 L7F/L8F Engine

GRID NO.

C-13

This grid covers:

Starter Motor

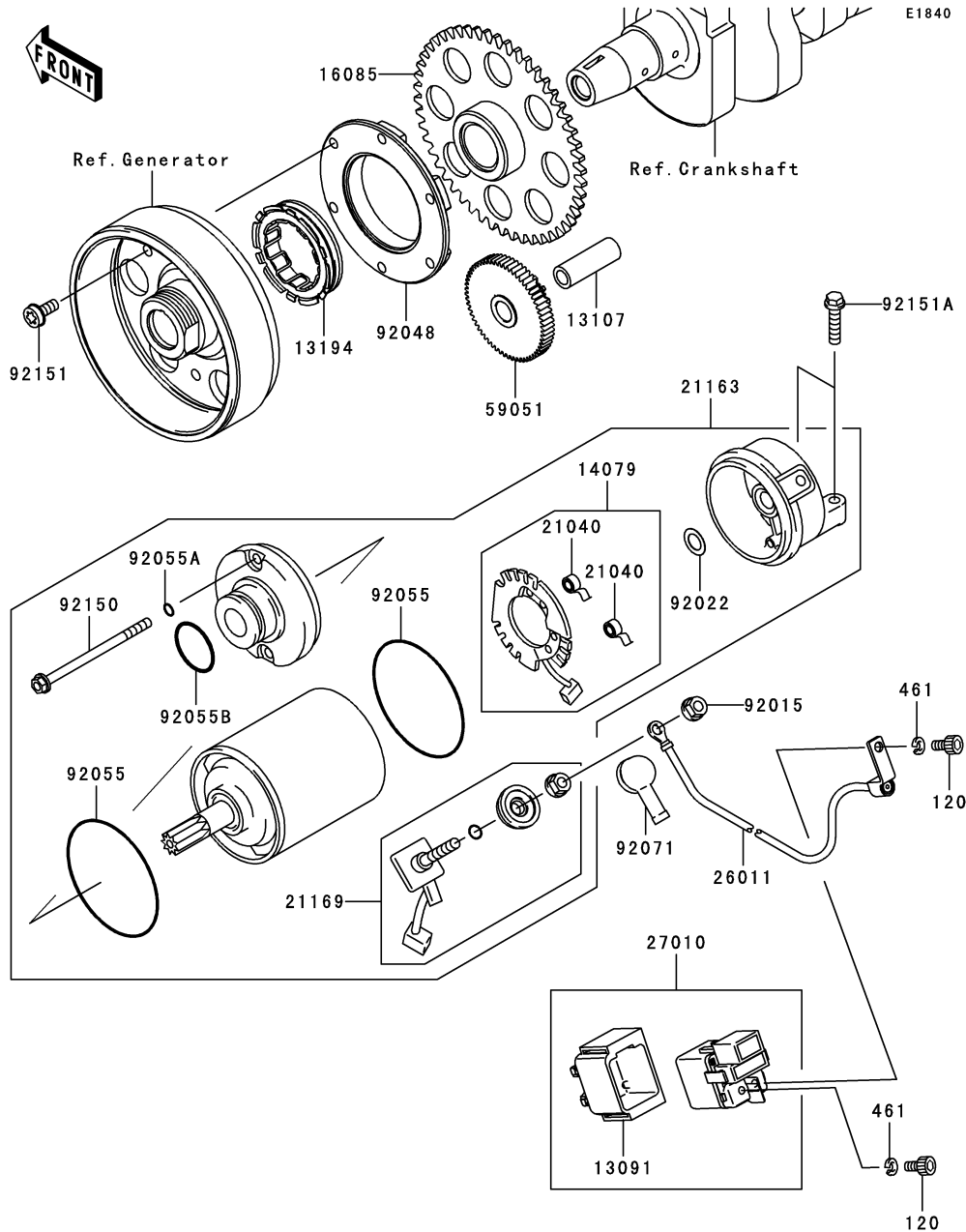

Ref. No.	Part No.	Description	Spec Code	Quantity-ZR750			
				'07	'08		
				L7F	L8F		
13091	13091-1992	HOLDER		1	1		
13107	13107-1377	SHAFT,IDLER GEAR		1	1		
13194	13194-1096	CLUTCH-ONEWAY		1	1		
14079	14079-0009	HOLDER-ASSY,STARTER		1	1		
16085	16085-1303	GEAR,CLUTCH ONEWAY		1	1		
21040	21040-0001	SPRING-BRUSH		2	2		
21163	21163-0024	STARTER-ELECTRIC		1	1		
21169	21169-1058	TERMINAL,STARTER		1	1		
26011	26011-0121	WIRE-LEAD		1	1		
27010	27010-1376	SWITCH,MAGNETIC		1	1		
59051	59051-0037	GEAR-SPUR,IDLER		1	1		
92015	92015-1623	NUT		1	1		
92022	92022-2200	WASHER		1	1		
92048	92048-1114	RACE,CLUTCH ONEWAY		1	1		
92055	92055-1260	RING-O,62MM		2	2		
92055A	92055-1261	RING-O,4.5MM		2	2		
92055B	92055-1262	RING-O,24.4X3.1		1	1		
92071	92071-1120	GROMMET,STARTER TERMINAL		1	1		
92150	92150-1237	BOLT		2	2		
92151	92151-1335	BOLT,6X14		6	6		
92151A	92151-1930	BOLT,FLANGED-SMALL,6X25		2	2		
120	120S0510	BOLT-SOCKET,5X10		2	2		
461	461K0500	WASHER-SPRING,5MM,BLACK		2	2		

This catalog covers:

'07~'08 ZR750 L7F/L8F Engine

GRID NO.

C-14

This grid covers:

Radiator

E3032

Ref. No.	Part No.	Description	Spec Code	Quantity-ZR750				
				'07	'08			
				L7F	L8F			
11054	11054-0646	BRACKET			1	1		
35063	35063-0321	STAY			1	1		
39060	39060-0034	RADIATOR			1	1		
49016	49016-0032	COVER-SEAL,HOT WIND			1	1		
59502	59502-0025	FAN-ASSY			1	1		
92002	92002-1086	BOLT,FLANGED,6X25			3	3		
92015	92015-1487	NUT			3	3		
92039	92039-0014	RIVET			2	2		
92039A	92039-0027	RIVET			2	2		
92075	92075-1123	DAMPER,RUBBER			3	3		
92150	92150-1186	BOLT,6X12			3	3		
92152	92152-1074	COLLAR			3	3		
92153	92153-1584	BOLT-FLANGED,6X16			1	1		

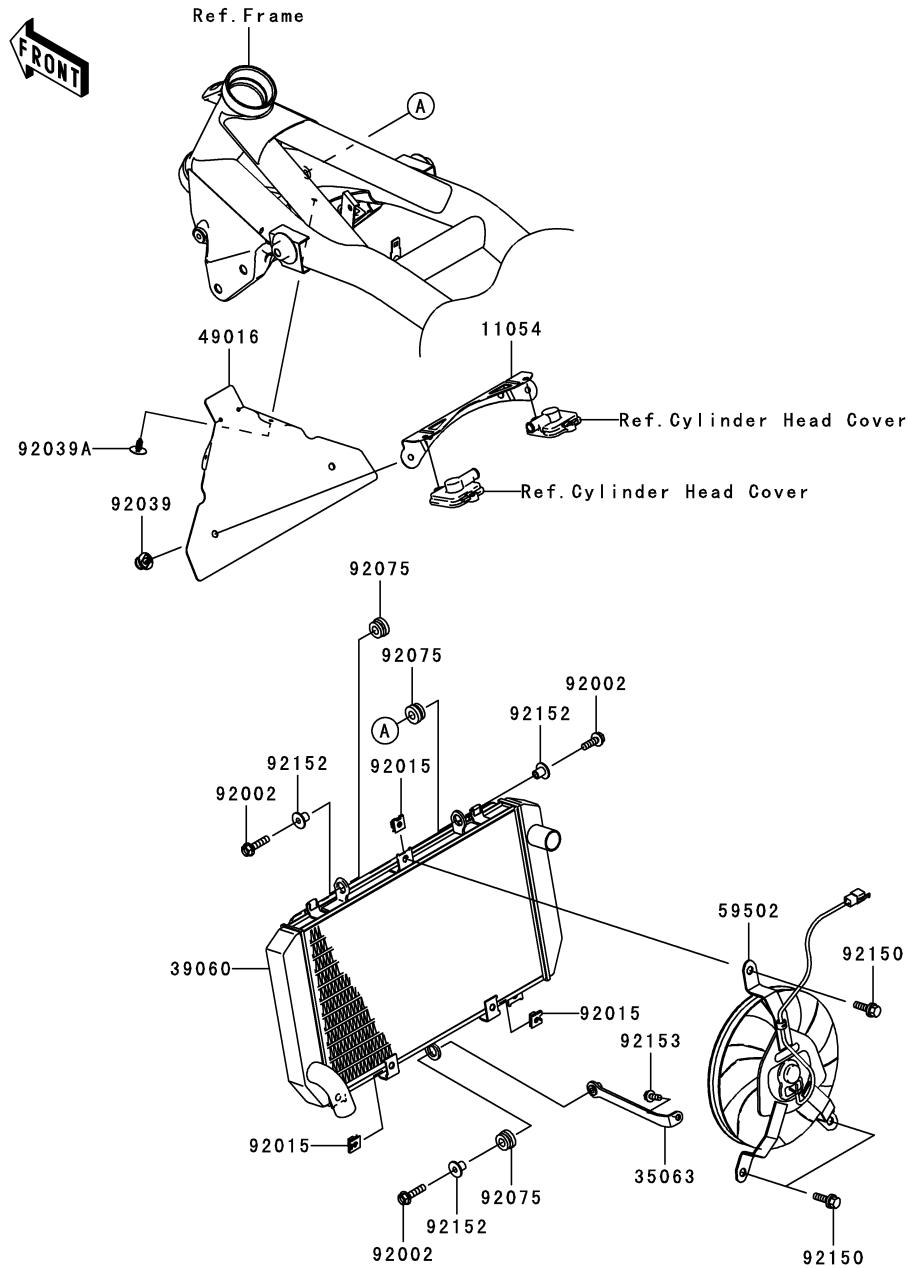

This catalog covers:

'07~'08 ZR750 L7F/L8F Engine

GRID NO.

D-3

This grid covers:

Water Pipe

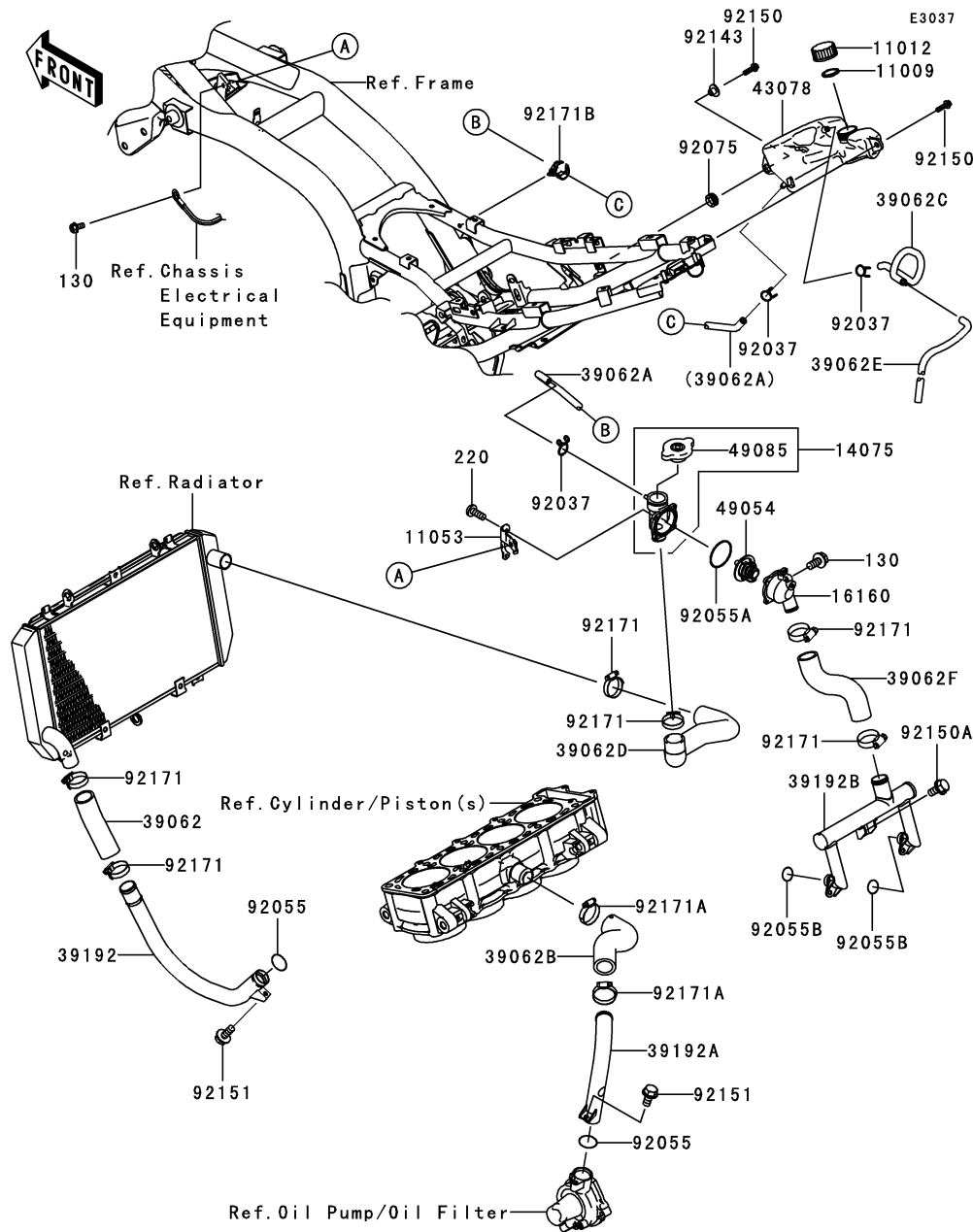

Ref. No.	Part No.	Description	Quantity-ZR750			
			'07	'08		
			L7F	L8F		
11009	11009-1145	GASKET,RESERVOIR TANK CAP	1	1		
11012	11012-1084	CAP	1	1		
11053	11053-1070	BRACKET,THERMOSTAT	1	1		
14075	14075-0001	CAP-ASSY	1	1		
16160	16160-0039	BODY,LWR	1	1		
39062	39062-0190	HOSE-COOLING,RAD-PIPE	1	1		
39062A	39062-0207	HOSE-COOLING,RESERVOIR	1	1		
39062B	39062-0208	HOSE-COOLING,PUMP-CYLINDER	1	1		
39062C	39062-0213	HOSE-COOLING,OVER FLOW	1	1		
39062D	39062-0234	HOSE-COOLING,THERMO-RAD	1	1		
39062E	39062-1226	HOSE-COOLING	1	1		
39062F	39062-1916	HOSE-COOLING,HEAD-THERMO	1	1		
39192	39192-0049	PIPE-WATER	1	1		
39192A	39192-0071	PIPE-WATER	1	1		
39192B	39192-1151	PIPE-WATER	1	1		
43078	43078-0033	RESERVOIR	1	1		
49054	49054-1067	THERMOSTAT	1	1		
49085	49085-1066	CAP-ASSY-PRESSURE	1	1		
92037	92037-147	CLAMP,TUBE	3	3		
92055	92055-0114	RING-O,20.8X2.4	2	2		
92055A	92055-112	RING-O,53.5X2.6	1	1		
92055B	92055-1350	RING-O,18.54X2.6	2	2		
92075	92075-1634	DAMPER	1	1		
92143	92143-1962	COLLAR	1	1		
92150	92150-1633	BOLT,FLANGED,6X20	2	2		
92150A	92150-1841	BOLT,FLANGED-SMALL,6X12	3	3		
92151	92151-1997	BOLT,6X12	2	2		
92171	92171-0179	CLAMP	6	6		
92171A	92171-0180	CLAMP	2	2		
92171B	92171-0864	CLAMP	1	1		
130	130J0612	BOLT-FLANGED,6X12	2	2		
220	220D0514	SCREW-PAN-CROS,5X14	4	4		

This catalog covers:

'07~'08 ZR750 L7F/L8F Chassis

GRID NO.

E-3

This grid covers:

Frame

F2120

Ref. No.	Part No.	Description	Spec Code	Quantity-ZR750			
				'07	'08		
				L7F	L8F		
32160	32160-0263-11E	FRAME-COMP,F.S.BLACK		1			
32160A	32160-0263-18R	FRAME-COMP,BLACK			1		
39156	39156-0292	PAD		1	1		
39156A	39156-0318	PAD		1			
39156B	39156-0343	PAD			1		
53044	53044-0018	TRIM		1	1		
92045	92045-1384	BEARING-BALL,SF07A17PX1V1		2	2		
92049	92049-0022	SEAL-OIL,DS35X55X4		1	1		
92049A	92049-1483	SEAL-OIL,MX043N2		1	1		
92066	92066-0071	PLUG		1	1		
92153	92153-0474	BOLT,26MM		1	1		
92200	92200-0081	WASHER,27X42X2.3		1	1		
92200A	92200-0281	WASHER		1	1		
92210	92210-0062	NUT,STEERING STEM 35MM		1	1		
92210A	92210-0077	NUT,STEERING STEM,35MM		1	1		

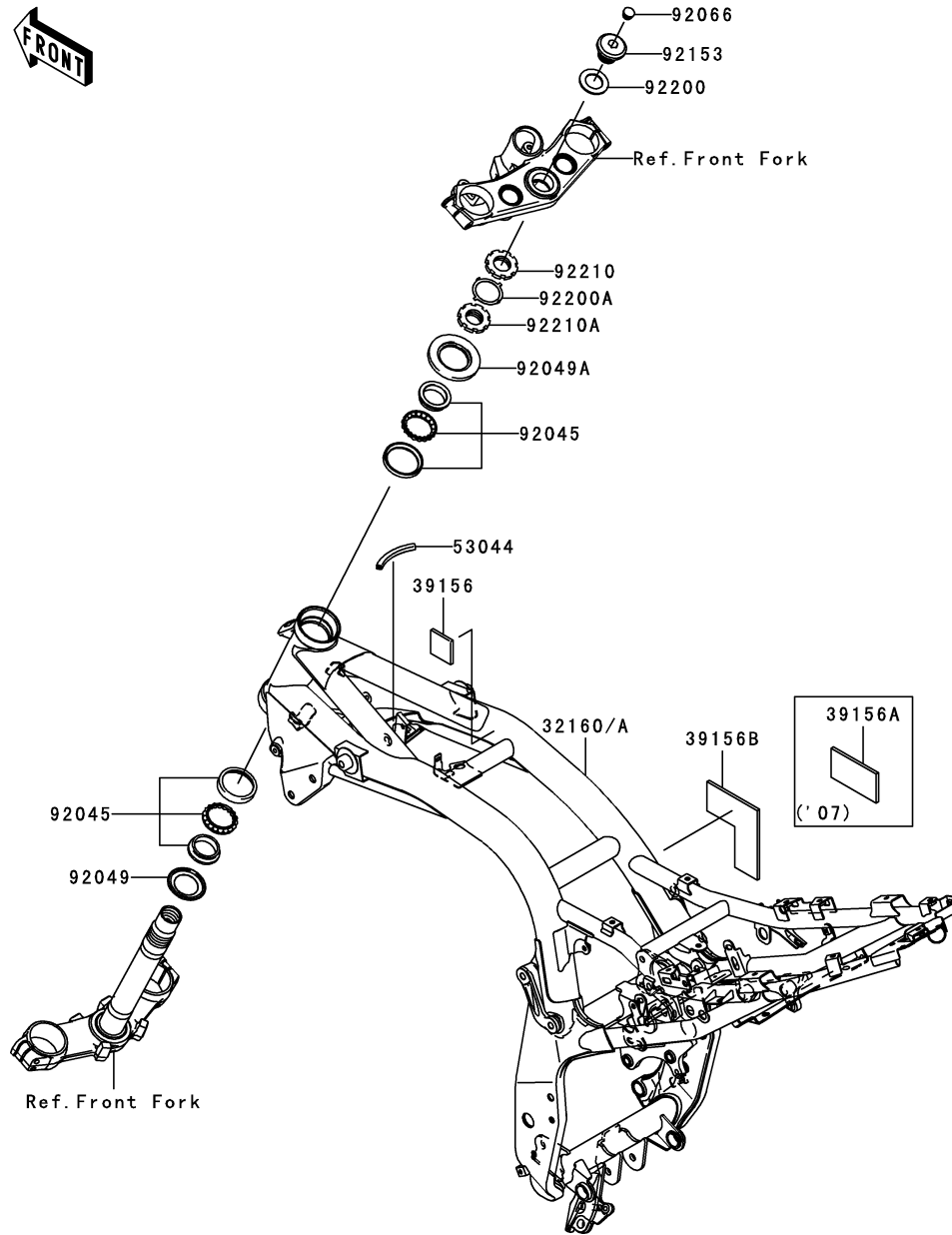

This catalog covers:

'07~'08 ZR750 L7F/L8F Chassis

GRID NO.

E-4

This grid covers:

Engine Mount

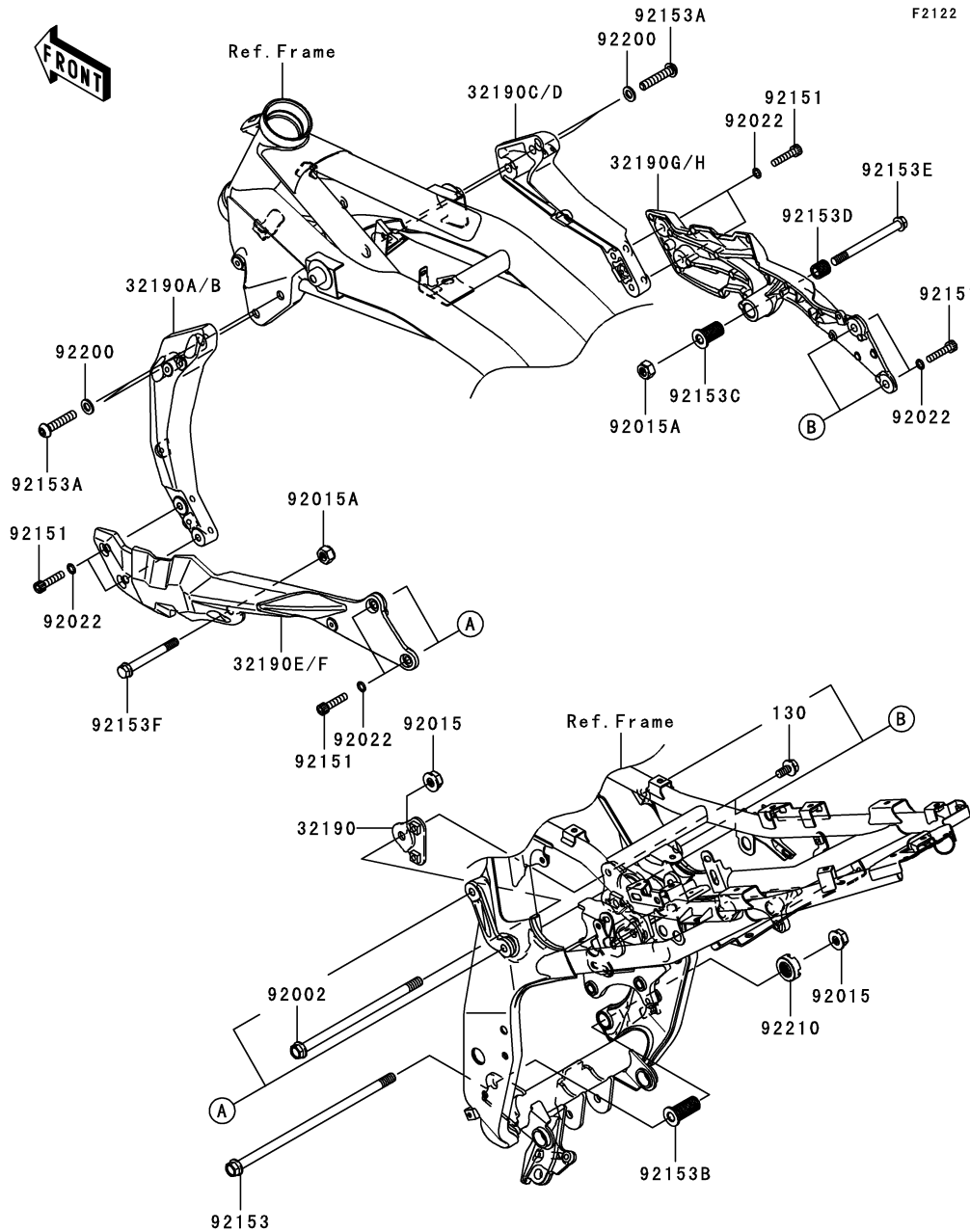

F2122

Ref. No.	Part No.	Description	Spec Code	Quantity-ZR750			
				'07	'08		
				L7F	L8F		
32190	32190-0009	BRACKET-ENGINE,RR,RH,UPP		1	1		
32190A	32190-0248-18R	BRACKET-ENGINE,FR,LH,BLACK			1		
32190B	32190-0248-7C	BRACKET-ENGINE,FR,LH,SILVER		1			
32190C	32190-0249-18R	BRACKET-ENGINE,FR,RH,BLACK				1	
32190D	32190-0249-7C	BRACKET-ENGINE,FR,RH,SILVER		1			
32190E	32190-0250-18R	BRACKET-ENGINE,RR,LH,BLACK					1
32190F	32190-0250-7C	BRACKET-ENGINE,RR,LH,SILVER		1			
32190G	32190-0251-18R	BRACKET-ENGINE,RR,RH,BLACK					1
32190H	32190-0251-7C	BRACKET-ENGINE,RR,RH,SILVER		1			
92002	92002-1337	BOLT,10X183		1	1		
92015	92015-1180	NUT,FLANGED,10MM		2	2		
92015A	92015-1189	NUT,LOCK,10MM,BLACK		2	2		
92022	92022-1028	WASHER,8.5X13X1		8	8		
92151	92151-1535	BOLT,SOCKET,8X35		8	8		
92153	92153-0559	BOLT,FLANGED,10X240		1	1		
92153A	92153-0858	BOLT,SOCKET,10X50		4	4		
92153B	92153-1098	BOLT,ENGINE MOUNT,18MM		1	1		
92153C	92153-1818	BOLT,ENGINE MOUNT,18MM		1	1		
92153D	92153-1819	BOLT,ENGINE MOUNT,18MM		1	1		
92153E	92153-1820	BOLT,FLANGED,10X113		1	1		
92153F	92153-1899	BOLT,FLANGED,10X85		1	1		
92200	92200-1042	WASHER,10.5X19X2.3		4	4		
92210	92210-1203	NUT,18MM		1	1		
130	130J0816	BOLT-FLANGED,8X16		2	2		

This catalog covers:

'07~'08 ZR750 L7F/L8F Chassis

GRID NO.

E-5

This grid covers:

Frame Fittings

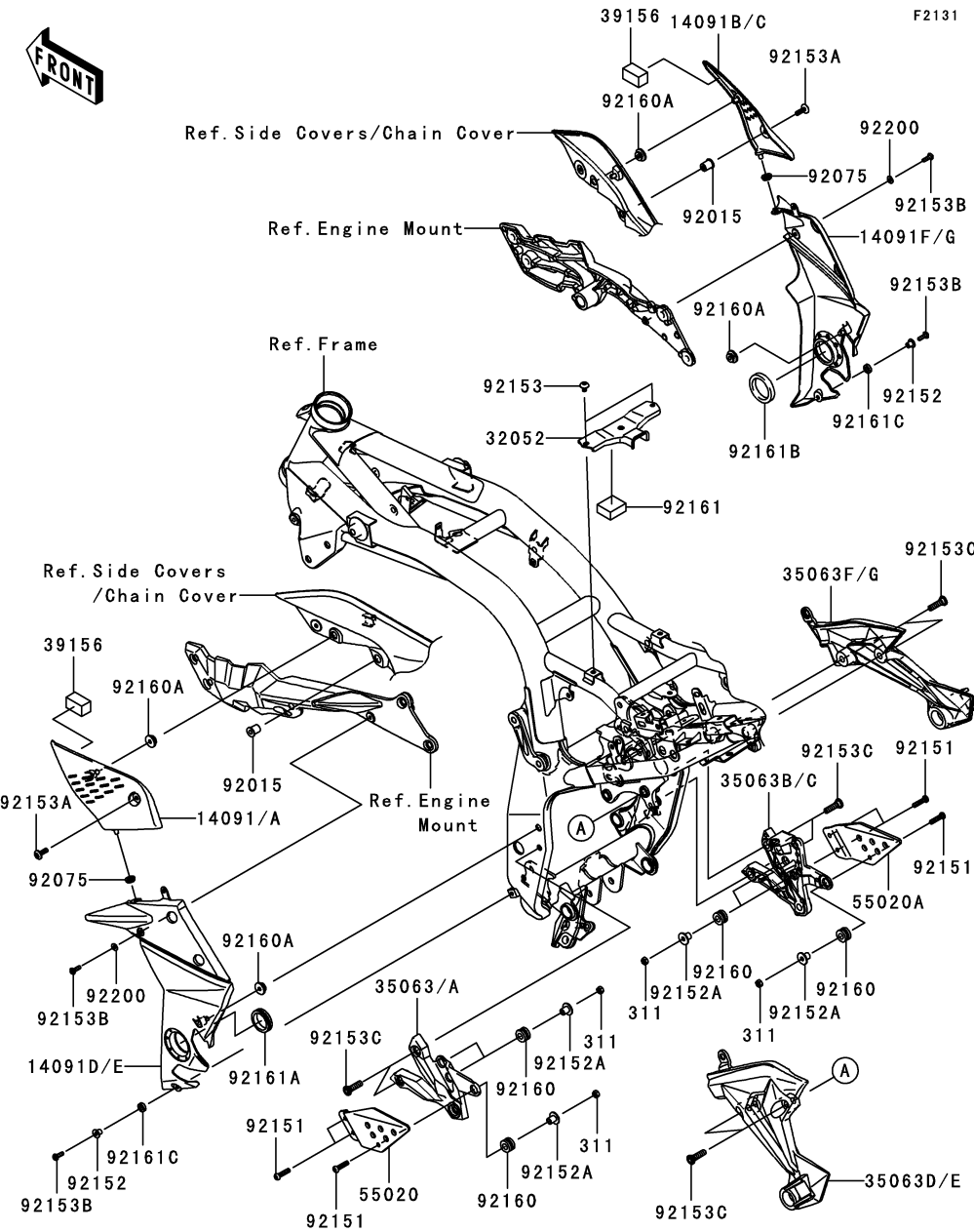

Ref. No.	Part No.	Description	Spec Code	Quantity-ZR750			
				'07	'08		
				L7F	L8F		
14091	14091-0689-18T	COVER,AIR CLEANER,LH,BLACK		1			
14091A	14091-0689-7C	COVER,AIR CLEANER,LH,SILVER		1			
14091B	14091-0690-18T	COVER,AIR CLEANER,RH,BLACK			1		
14091C	14091-0690-7C	COVER,AIR CLEANER,RH,SILVER		1			
14091D	14091-0815-18T	COVER,PIVOT,LH,BLACK			1		
14091E	14091-0815-7C	COVER,PIVOT,LH,SILVER		1			
14091F	14091-0816-18T	COVER,PIVOT,RH,BLACK			1		
14091G	14091-0816-7C	COVER,PIVOT,RH,SILVER		1			
32052	32052-0068	BRACKET-TANK		1	1		
35063	35063-0299-18R	STAY,FR,LH,BLACK			1		
35063A	35063-0299-458	STAY,FR,LH,P,SILVER		1			
35063B	35063-0300-18R	STAY,FR,RH,BLACK			1		
35063C	35063-0300-458	STAY,FR,RH,P,SILVER		1			
35063D	35063-0301-11E	STAY,RR,LH,F,S,BLACK		1			
35063E	35063-0301-18R	STAY,RR,LH,BLACK			1		
35063F	35063-0302-11E	STAY,RR,RH,F,S,BLACK		1			
35063G	35063-0302-18R	STAY,RR,RH,BLACK			1		
39156	39156-0345	PAD		2	2		
55020	55020-0237	GUARD,FRONT STEP STAY,LH		1	1		
55020A	55020-0238	GUARD,FRONT STEP STAY,RH		1	1		
92015	92015-1700	NUT		2	2		
92075	92075-1011	DAMPER		2	2		
92151	92151-1924	BOLT,SOCKET,6X25		6	6		
92152	92152-0600	COLLAR		2	2		
92152A	92152-1074	COLLAR		6	6		
92153	92153-0410	BOLT,SOCKET,6X10		2	2		
92153A	92153-0816	BOLT,6X18		2	2		
92153B	92153-1244	BOLT,SOCKET,5X16		4	4		
92153C	92153-1624	BOLT,SOCKET,8X30		8	8		
92160	92160-1167	DAMPER		6	6		
92160A	92160-1613	DAMPER		4	4		
92161	92161-0063	DAMPER		1	1		
92161A	92161-0147	DAMPER		1	1		
92161B	92161-0148	DAMPER		1	1		
92161C	92161-0533	DAMPER		2	2		
92200	92200-0006	WASHER,NYLONE,5.3X11.5X0.5		2	2		
311	311AA0600	NUT-HEX,6MM		6	6		

This catalog covers:

'07~'08 ZR750 L7F/L8F Chassis

GRID NO.

E-6

This grid covers:

Battery Case

F2132

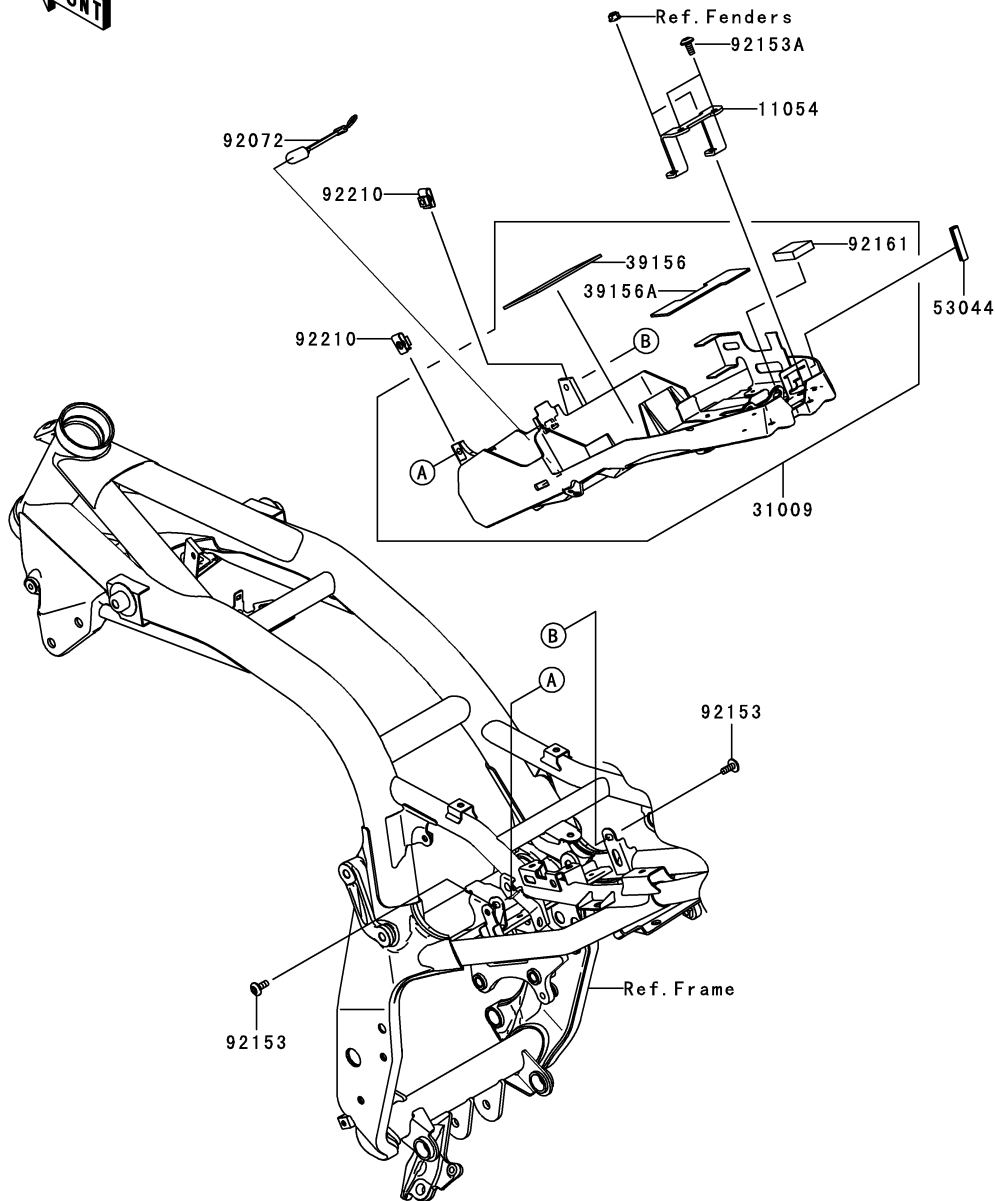

Ref. No.	Part No.	Description	Quantity-ZR750			
			'07	'08		
			L7F	L8F		
11054	11054-0751	BRACKET,BATTERY CASE,RR	1	1		
31009	31009-0004	CASE-COMP-BATTERY	1	1		
39156	39156-0288	PAD	1	1		
39156A	39156-0317	PAD	1	1		
53044	53044-0012	TRIM,L=40	1	1		
92072	92072-0090	BAND,U LOCK	1	1		
92153	92153-1526	BOLT,SOCKET,6X16	2	2		
92153A	92153-1612	BOLT,SOCKET,6X14	2	2		
92161	92161-0281	DAMPER	1	1		
92210	92210-0318	NUT	2	2		

This catalog covers:

'07~'08 ZR750 L7F/L8F Chassis

GRID NO.

E-7

This grid covers:

Swingarm

F2141

Ref. No.	Part No.	Description	Spec Code	Quantity-ZR750			
				'07	'08		
				L7F	L8F		
11065	11065-0055	CAP,CHAIN ADJUSTER		2	2		
33001	33001-0103-11E	ARM-COMP-SWING,F.S.BLACK		1			
33001A	33001-0103-18R	ARM-COMP-SWING,BLACK			1		
33032	33032-0005	SHAFT-SWING ARM		1	1		
33040	33040-0009	ADJUSTER-CHAIN,OUTER,LH		1	1		
33040A	33040-0012	ADJUSTER-CHAIN,INNER		2	2		
33040B	33040-1143	ADJUSTER-CHAIN,OUTER,RH		1	1		
42036	42036-1264	SLEEVE,SWING ARM,L=237		1	1		
55020	55020-0061	GUARD,CHAIN		1	1		
92015	92015-1724	NUT,FLANGED,20MM		1	1		
92022	92022-1582	WASHER,8.5X16X1.2		2	2		
92033	92033-1041	RING-SNAP,42MM		1	1		
92045	92045-0017	BEARING-BALL,6004UL11		1	1		
92046	92046-0008	BEARING-NEEDLE,7E-HVS 28X34X17		2	2		
92049	92049-1181	SEAL-OIL		1	1		
92049A	92049-1380	SEAL-OIL,MHA 35 42 5.7F		1	1		
92151	92151-1149	BOLT,SOCKET,6X18		1	1		
92152	92152-0136	COLLAR,SWING ARM PIVOT,RH		1	1		
92171	92171-0141	CLAMP		1	1		
92210	92210-0116	NUT,8MM		2	2		
92210A	92210-0117	NUT,8MM		2	2		
92210B	92210-1347	NUT,28X1.0		1	1		
92210C	92210-1397	NUT,POP,6MM,L=15		1	1		
130	130L0612	BOLT-FLANGED,6X12		1	1		

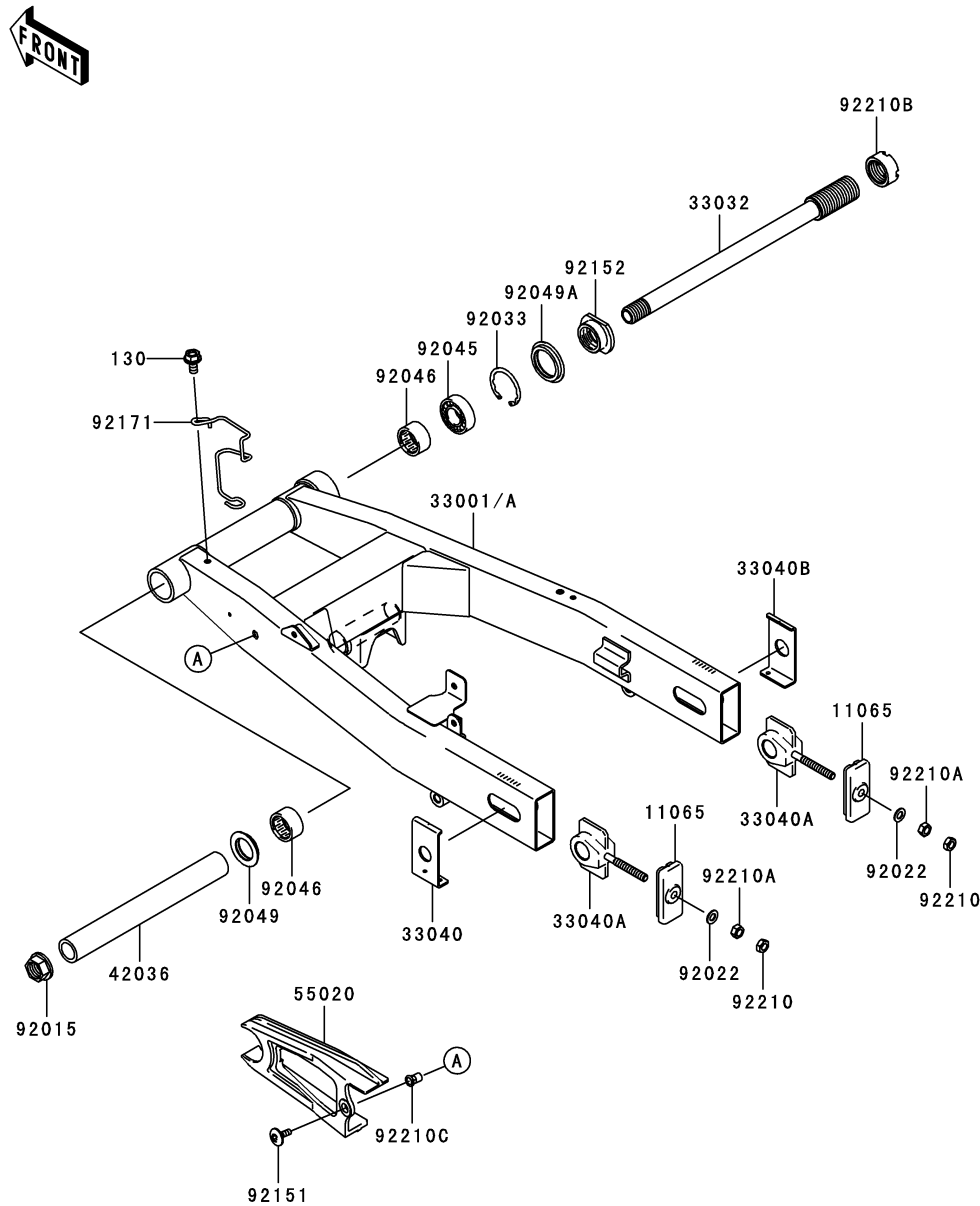

This catalog covers:

'07~'08 ZR750 L7F/L8F Chassis

GRID NO.

E-8

This grid covers:

Suspension

F2150

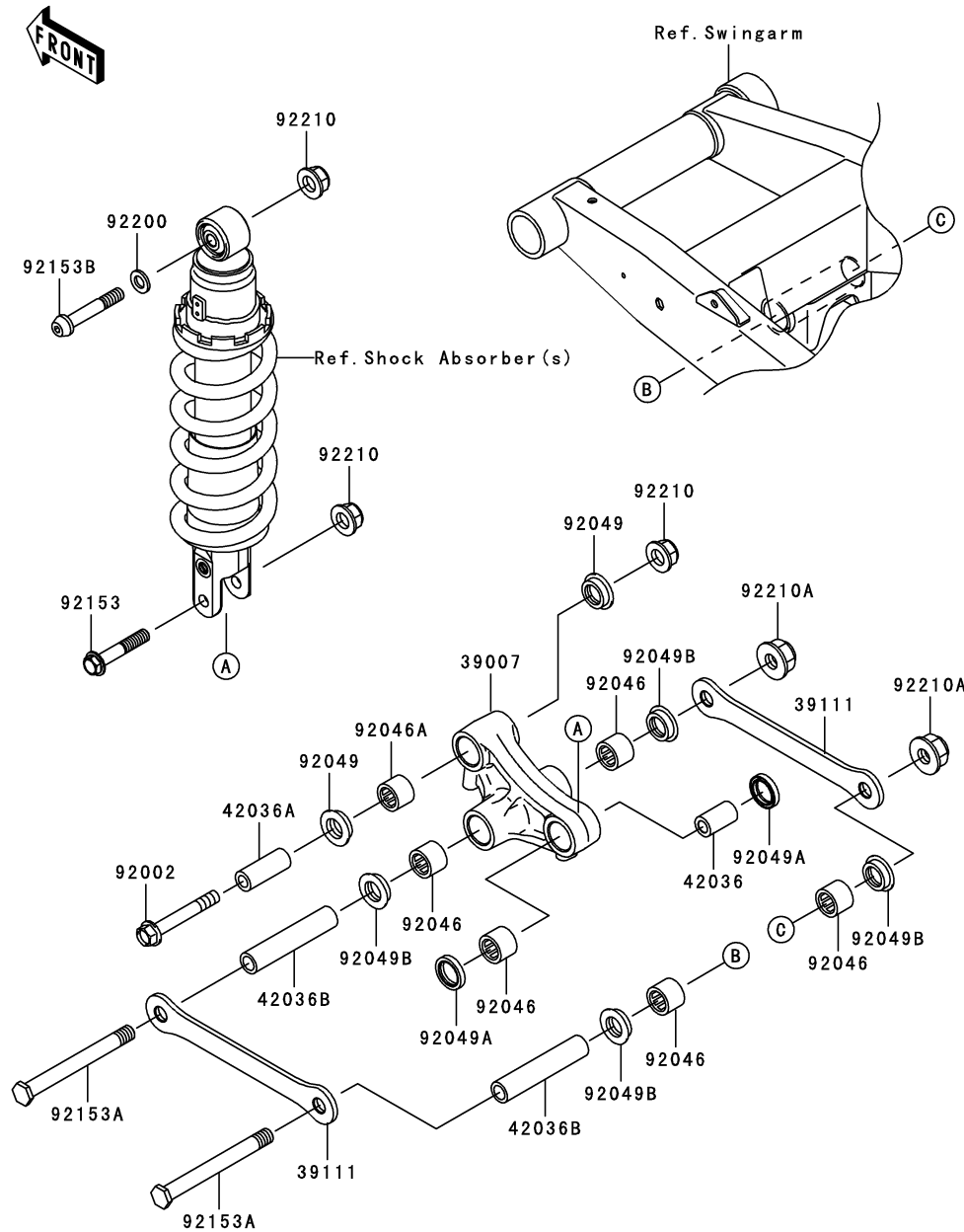

Ref. No.	Part No.	Description	Quantity-ZR750			
			'07	'08		
			L7F	L8F		
39007	39007-0006	ARM-SUSP,UNI TRAK	1	1		
39111	39111-0050	ROD-TIE,SUSPENSION	2	2		
42036	42036-1258	SLEEVE,10.1X18X30	1	1		
42036A	42036-1342	SLEEVE,10.1X17X44.5	1	1		
42036B	42036-1360	SLEEVE,12.1X18X90	2	2		
92002	92002-1183	BOLT,10X70	1	1		
92046	92046-1272	BEARING-NEEDLE,SFYZM182417	5	5		
92046A	92046-1273	BEARING-NEEDLE,SFYZM172425	1	1		
92049	92049-1223	SEAL-OIL,MHA17245.7F	2	2		
92049A	92049-1225	SEAL-OIL,MHA18244	2	2		
92049B	92049-1493	SEAL-OIL,KCR MF018N1	4	4		
92153	92153-1546	BOLT,FLANGED,10X55	1	1		
92153A	92153-1662	BOLT,12X114	2	2		
92153B	92153-1837	BOLT,SOCKET,10X60	1	1		
92200	92200-1042	WASHER,10.5X19X2.3	1	1		
92210	92210-0321	NUT,LOCK,FLANGED,10MM	3	3		
92210A	92210-1150	NUT,LOCK,FLANGED,12MM	2	2		

This catalog covers:

'07~'08 ZR750 L7F/L8F Chassis

GRID NO.

E-9

This grid covers:

Footrests

F2160

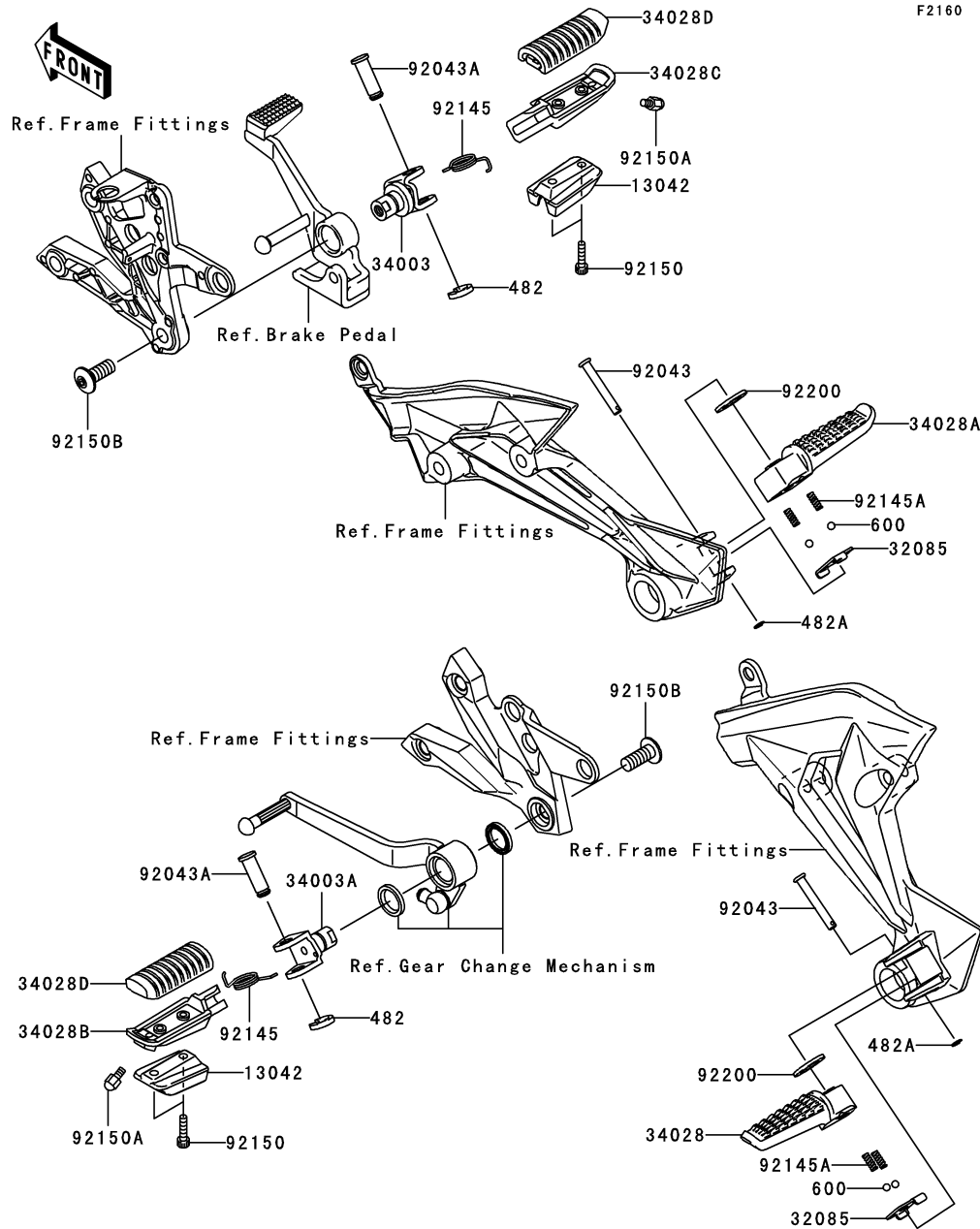

Ref. No.	Part No.	Description	Spec Code	Quantity-ZR750			
				'07	'08		
				L7F	L8F		
13042	13042-0022	WEIGHT,STEP	2	2			
32085	32085-0047	STOPPER,REAR STEP	2	2			
34003	34003-0025	HOLDER-STEP,FR,RH	1	1			
34003A	34003-1474	HOLDER-STEP	1	1			
34028	34028-0004	STEP,RR,LH	1	1			
34028A	34028-0005	STEP,RR,RH	1	1			
34028B	34028-1428	STEP,FR,LH	1	1			
34028C	34028-1429	STEP,FR,RH	1	1			
34028D	34028-1430	STEP,FR,RUBBER	2	2			
92043	92043-1595	PIN,6X40	2	2			
92043A	92043-1641	PIN,12X37	2	2			
92145	92145-0360	SPRING,STEP RETURN,LH	2	2			
92145A	92145-1319	SPRING	4	4			
92150	92150-1019	BOLT,SOCKET,5X20	4	4			
92150A	92150-1114	BOLT,BANK SENSOR	2	2			
92150B	92150-1268	BOLT,SOCKET,10X25	2	2			
92200	92200-0043	WASHER,16X26X2.3	2	2			
482	482L0100	CIRCLIP-TYPE-E,10MM	2	2			
482A	482L5000	CIRCLIP-TYPE-E,5MM	2	2			
600	600A0800	BALL-STEEL,1/4"	4	4			

This catalog covers:

'07~'08 ZR750 L7F/L8F Chassis

GRID NO.

E-10

This grid covers:

Fenders

F2170

Ref. No.	Part No.	Description	Spec Code	Quantity-ZR750			
				'07	'08		
				L7F	L8F		
11054	11054-1921	BRACKET,FLAP,LH	1	1			
11054A	11054-1922	BRACKET,FLAP,RH	1	1			
32065	32065-0002	BRACKET-FENDER,LH	1	1			
32065A	32065-0003	BRACKET-FENDER,RH	1	1			
35004	35004-0024-H8	FENDER-FRONT,EBONY	1	1			
35004A	35004-0024-17H	FENDER-FRONT,P.ORANGE		1			
35004B	35004-0024-17M	FENDER-FRONT,SILVER	1				
35004C	35004-0024-17P	FENDER-FRONT,C.L.GREEN	1				
35004D	35004-0024-726	FENDER-FRONT,M.O.BLUE		1			
35019	35019-0047	FLAP	1	1			
39156	39156-0284	PAD	2	2			
39156A	39156-0285	PAD	2	2			
92015	92015-1603	NUT,LOCK,FLANGED,6MM	2	2			
92039	92039-1286	RIVET	2	2			
92152	92152-0577	COLLAR	2	2			
92153	92153-0589	BOLT,FLANGED,6X14	4	4			
92153A	92153-1267	BOLT,SOCKET,6X23	4	4			
92153B	92153-1612	BOLT,SOCKET,6X14	2	2			
92153C	92153-1873	BOLT,6X35	2	2			
92160	92160-1278	DAMPER	2	2			
92200	92200-1388	WASHER,6.5X14X1	4	4			

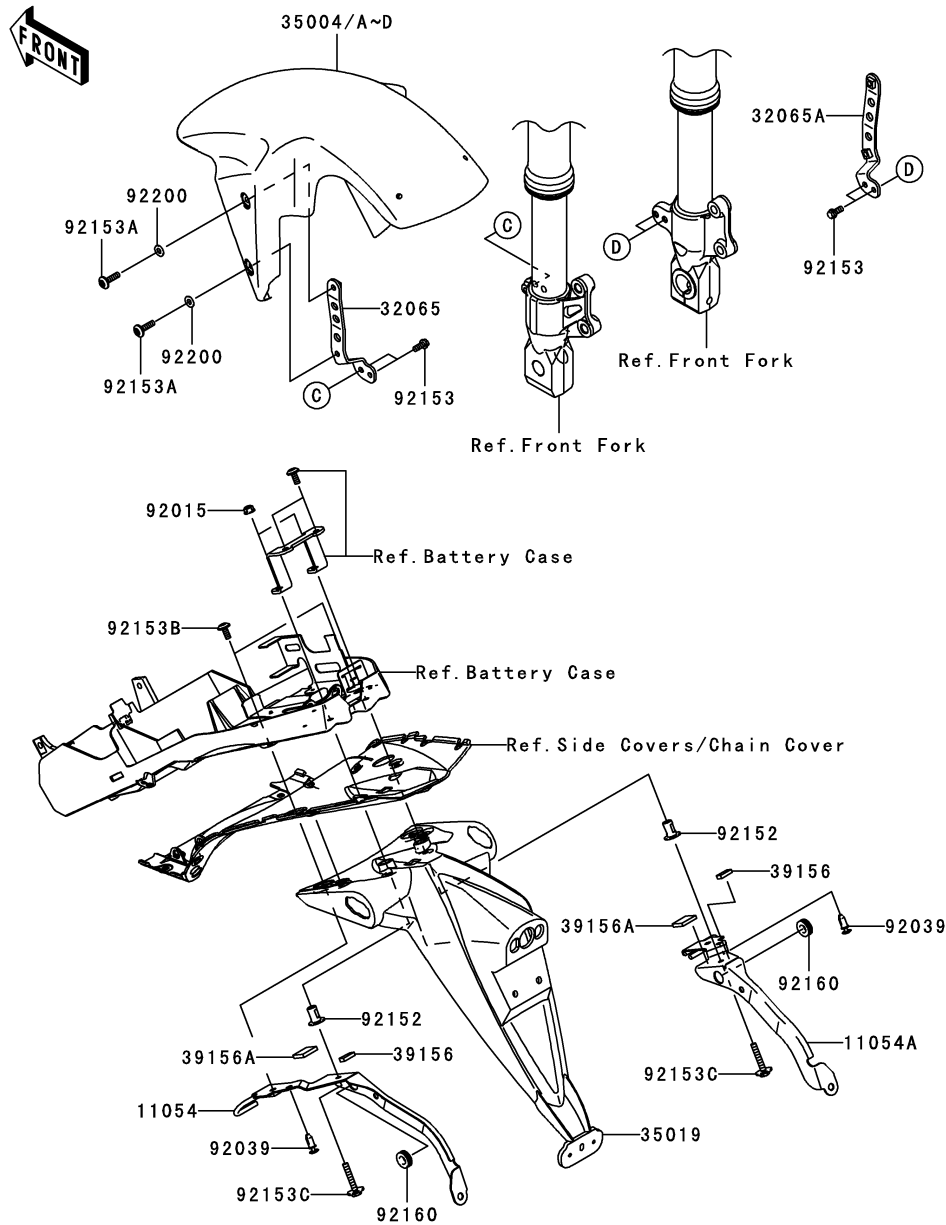

This catalog covers:

'07~'08 ZR750 L7F/L8F Chassis

GRID NO.

E-11

This grid covers:

Stand(s)



F2190

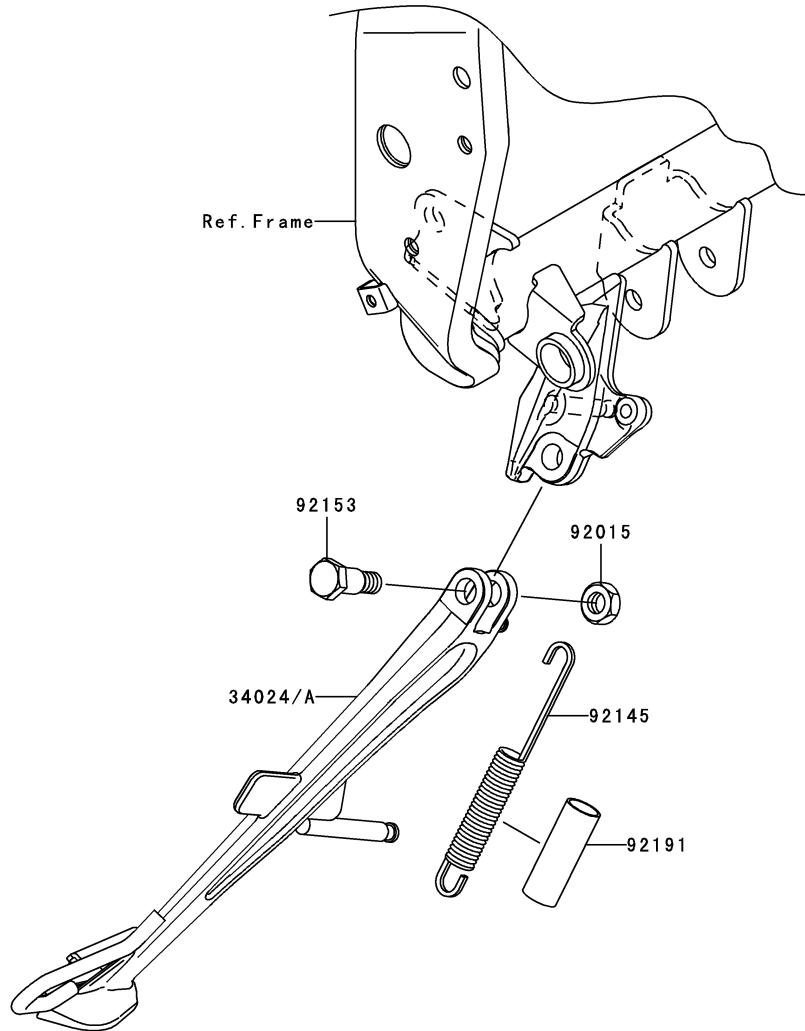

Ref. No.	Part No.	Description	Spec Code	Quantity-ZR750			
				'07	'08		
				L7F	L8F		
34024	34024-0056-11E	STAND-SIDE,F.S.BLACK		1			
34024A	34024-0058-18R	STAND-SIDE,BLACK			1		
92015	92015-1188	NUT,LOCK,10MM,BLACK		1	1		
92145	92145-0515	SPRING,SIDE STAND		1	1		
92153	92153-1871	BOLT,SIDE STAND,10MM		1	1		
92191	92191-1001	TUBE,13X16X60		1	1		

This catalog covers:

'07~'08 ZR750 L7F/L8F Chassis

GRID NO.

E-12

This grid covers:

Tires

F2210

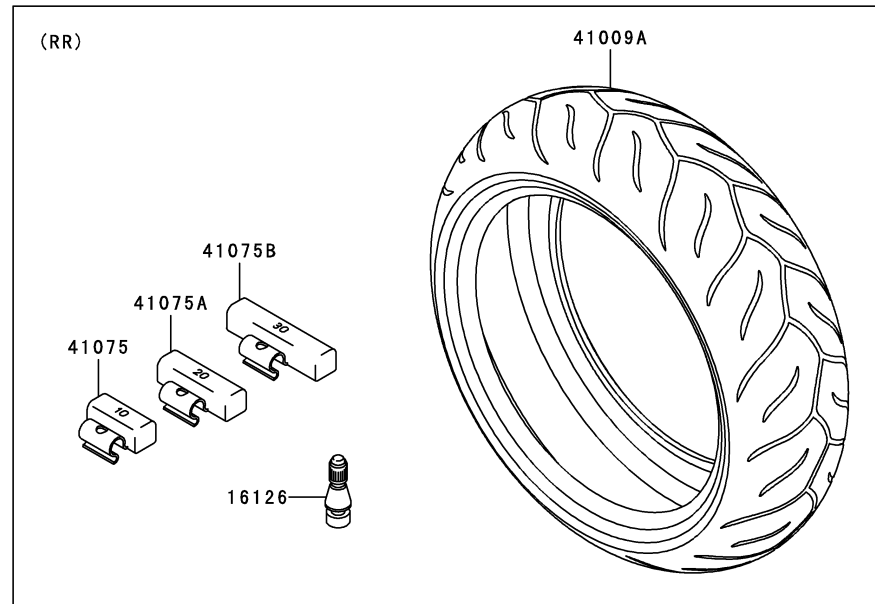
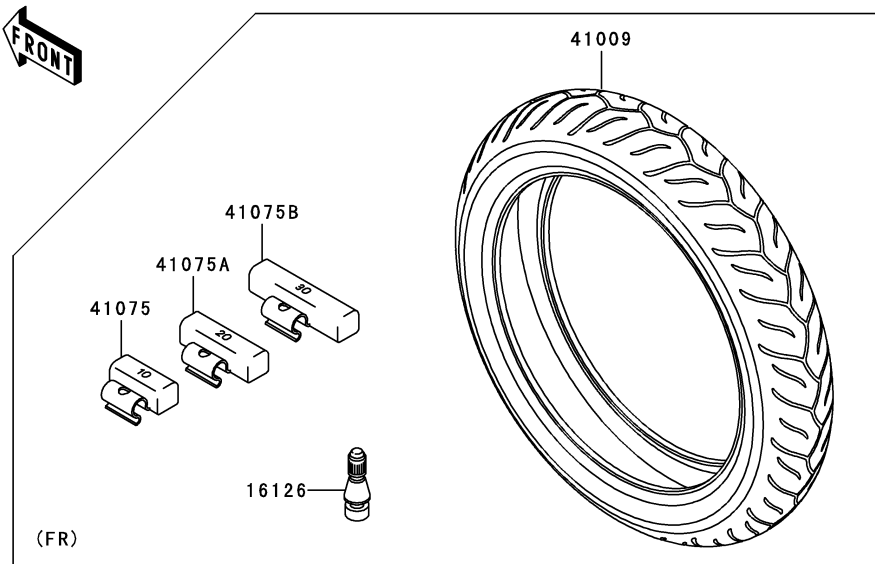

Ref. No.	Part No.	Description	Spec Code	Quantity-ZR750			
				'07	'08		
				L7F	L8F		
16126	16126-1140	VALVE,TIRE		2	2		
41009	41009-0173	TIRE,FR,120/70ZR17(58W)		1	1		
41009A	41009-0174	TIRE,RR,180/55ZR17(73W)		1	1		
41075	41075-0007	BALANCER-WHEEL,10G,SILVER		AR	AR		
41075A	41075-0008	BALANCER-WHEEL,20G,SILVER		AR	AR		
41075B	41075-0009	BALANCER-WHEEL,30G,SILVER		AR	AR		

This catalog covers:

'07~'08 ZR750 L7F/L8F Chassis

GRID NO.

E-13

This grid covers:

Front Hub

F2230

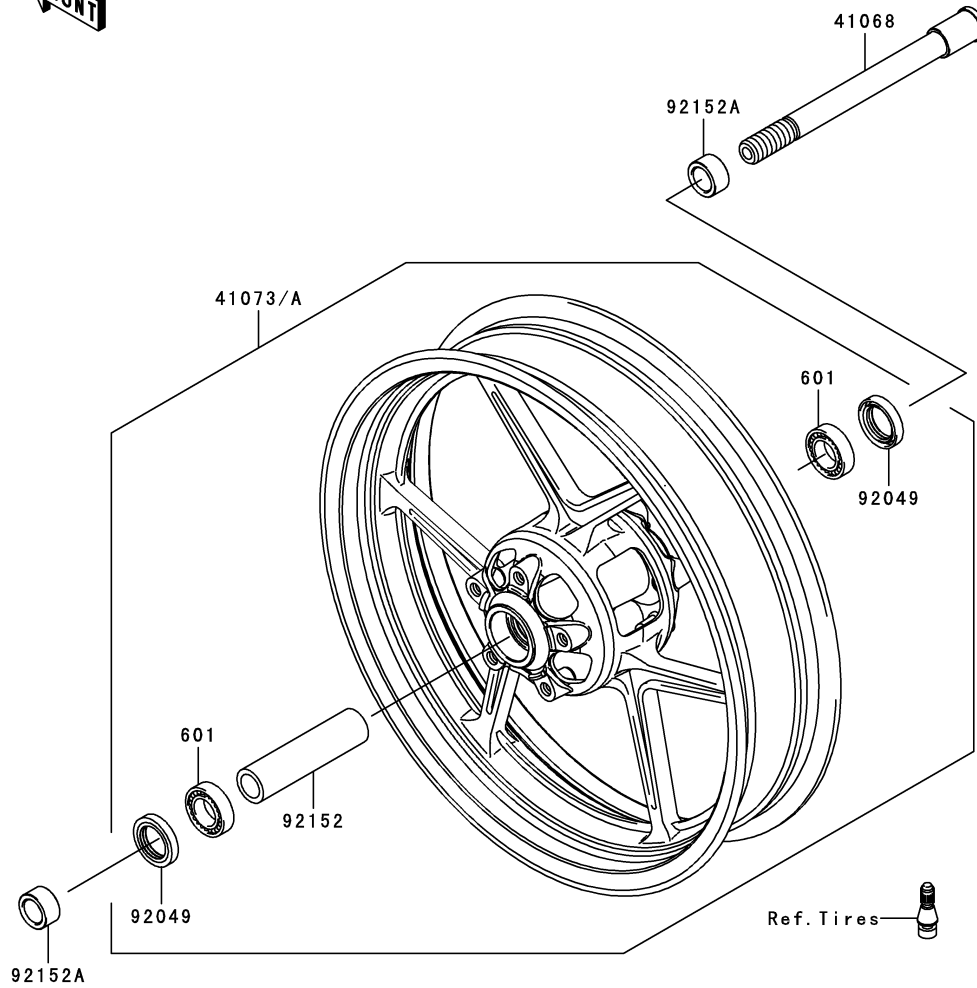

Ref. No.	Part No.	Description	Quantity-ZR750			
			'07	'08		
			L7F	L8F		
41068	41068-0038	AXLE,FR	1	1		
41073	41073-0053-R2	WHEEL-ASSY,FR,BLACK	1	1		
41073A	41073-0053-795	WHEEL-ASSY,FR,M.F.SILVER	1	1		
92049	92049-1057	SEAL-OIL,BJN30427-C3	2	2		
92152	92152-0087	COLLAR,FR HUB,L=115	1	1		
92152A	92152-0310	COLLAR,FR AXLE,L=15.5	2	2		
601	601B6004UU	BEARING-BALL,#6004UUC3	2	2		

This catalog covers:

'07~'08 ZR750 L7F/L8F Chassis

GRID NO.

E-14

This grid covers:

Rear Hub

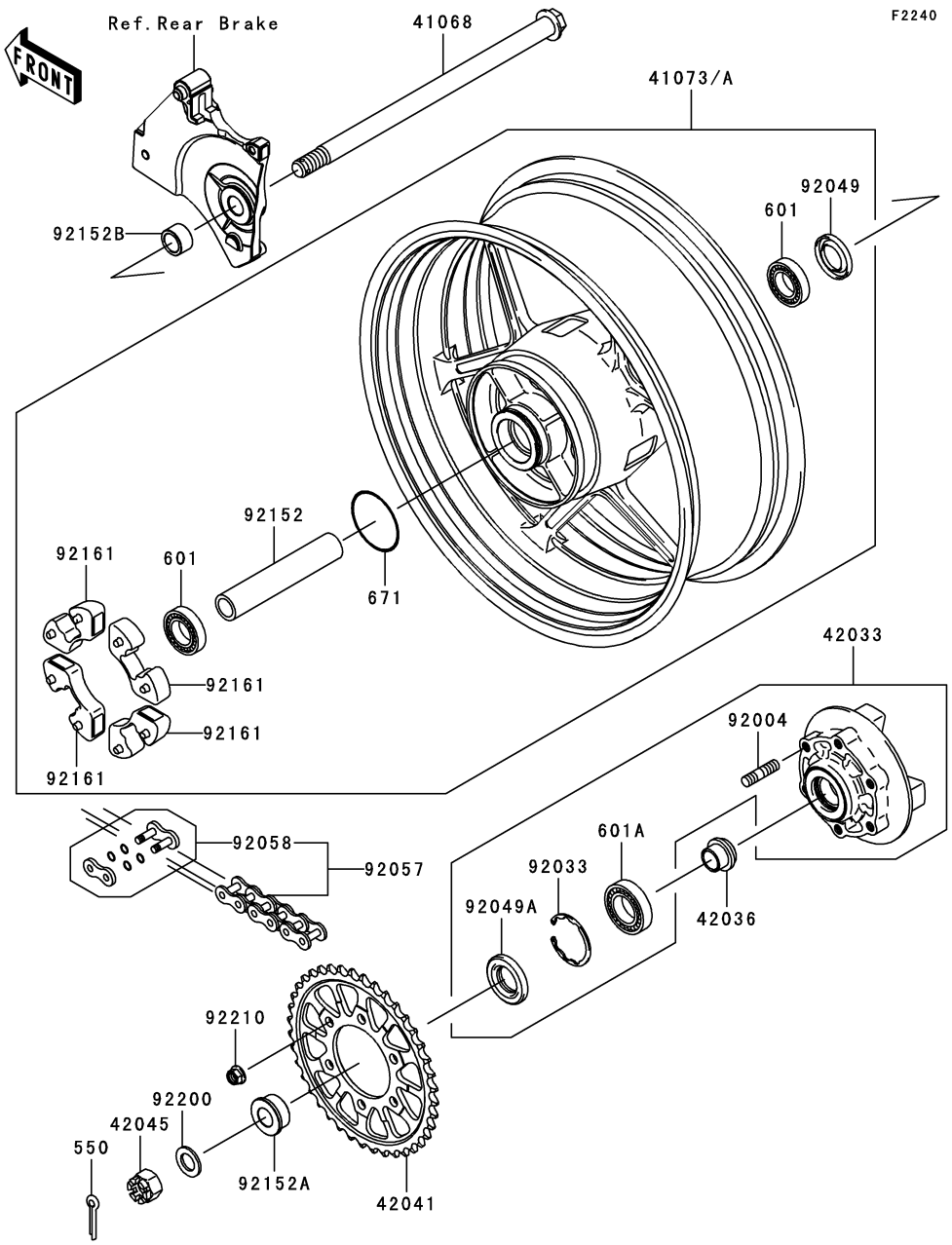

F2240

Ref. No.	Part No.	Description	Spec Code	Quantity-ZR750			
				'07	'08		
				L7F	L8F		
41068	41068-0023	AXLE,RR	1	1			
41073	41073-0115-R2	WHEEL-ASSY,RR,BLACK	1	1			
41073A	41073-0115-795	WHEEL-ASSY,RR,M.F.P.SILVER	1	1			
42033	42033-0003	COUPLING-ASSY,RR HUB	1	1			
42036	42036-1251	SLEEVE,RR HUB,L=23	1	1			
42041	42041-0017	SPROCKET-HUB,43T	1	1			
42045	42045-018	NUT,CASTLE,18MM	1	1			
92004	92004-0028	STUD,10X19	6	6			
92033	92033-1043	RING-SNAP,52MM	1	1			
92049	92049-1056	SEAL-OIL,BJN28475	1	1			
92049A	92049-1287	SEAL-OIL	1	1			
92057	92057-0129	CHAIN,DRIVE,EK520MVXL1X112L	1	1			
92058	92058-0007	JOINT-CHAIN,DRIVE	1	1			
92152	92152-0070	COLLAR,RR HUB,L=150	1	1			
92152A	92152-0118	COLLAR,RR AXLE,LH,L=18	1	1			
92152B	92152-0559	COLLAR,RR AXLE,RH,L=16.4	1	1			
92161	92161-0342	DAMPER,SHOCK,RR HUB	4	4			
92200	92200-1489	WASHER,19X32X2.6	1	1			
92210	92210-0276	NUT,LOCK,FLANGED,10MM	6	6			
550	550D4035	PIN-COTTER,4.0X35	1	1			
601	601B6204UU	BEARING-BALL,6204UUC3	2	2			
601A	601B6205UU	BEARING-BALL	1	1			
671	671B2560	O RING,60MM	1	1			

This catalog covers:

'07~'08 ZR750 L7F/L8F Chassis

GRID NO.

F-3

This grid covers:

Brake Pedal

F2260

Ref. No.	Part No.	Description	Spec Code	Quantity-ZR750			
				'07	'08		
				L7F	L8F		
13236	13236-0143	LEVER-COMP,BRAKE PEDAL		1	1		
92145	92145-0435	SPRING,BRAKE PEDAL RETURN		1	1		
92191	92191-1739	TUBE,12X15X40		1	1		

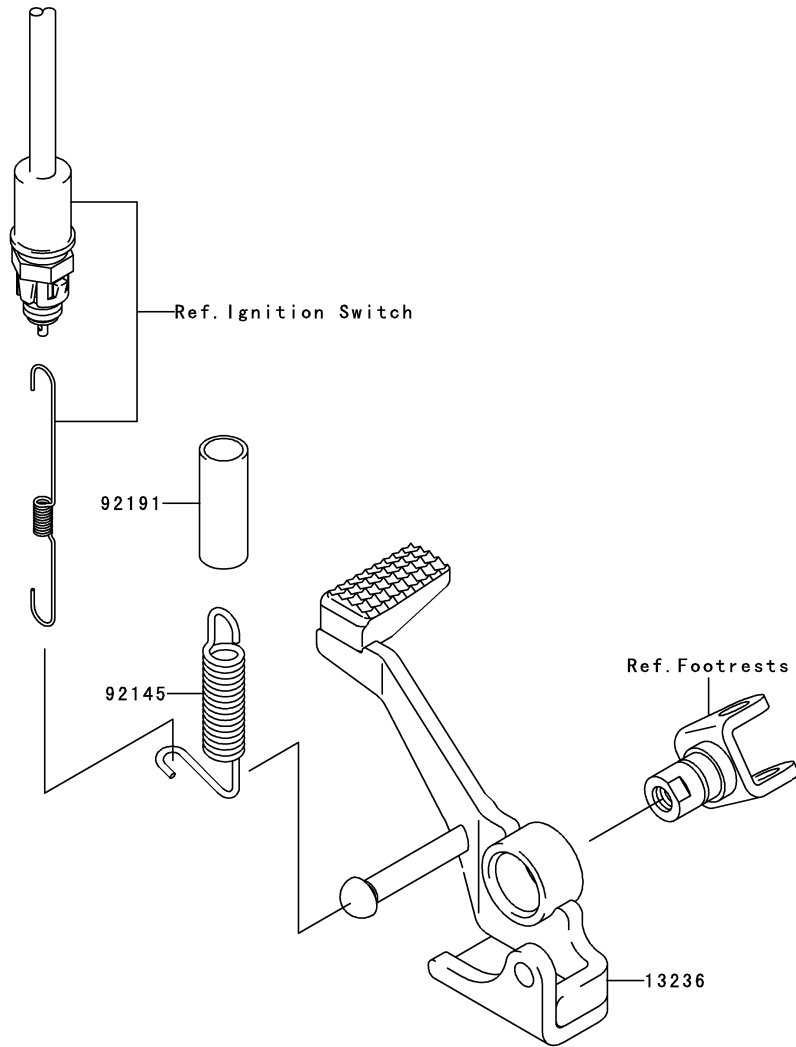

This catalog covers:

'07~'08 ZR750 L7F/L8F Chassis

GRID NO.

F-4

This grid covers:

Shock Absorber(s)

F2280

Ref. No.	Part No.	Description	Spec Code	Quantity-ZR750			
				'07	'08		
45014	45014-0195-23A	SHOCKABSORBER,SPG SIL+BODY BLK		1	1		
92092	92092-1058	BUSHING-RUBBER		1	1		

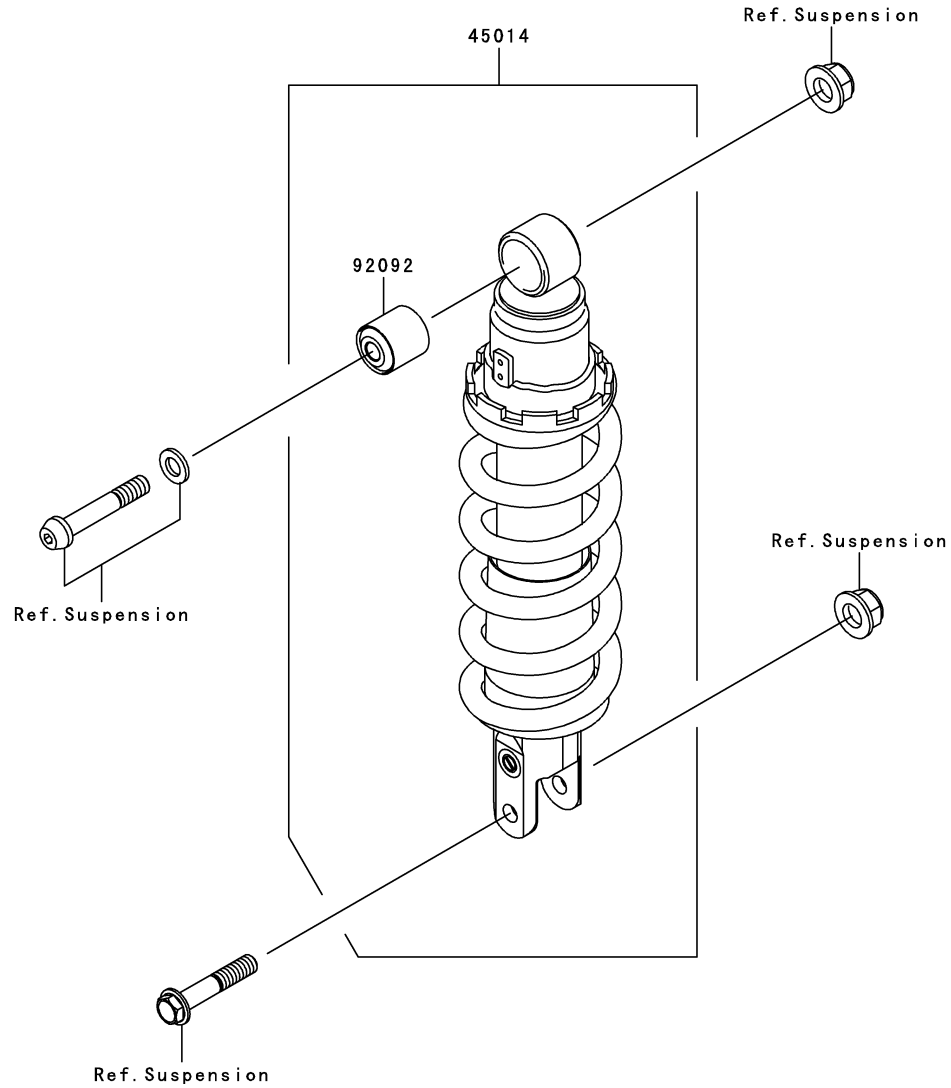

This catalog covers:

'07~'08 ZR750 L7F/L8F Chassis

GRID NO.

F-5

This grid covers:

Front Master Cylinder

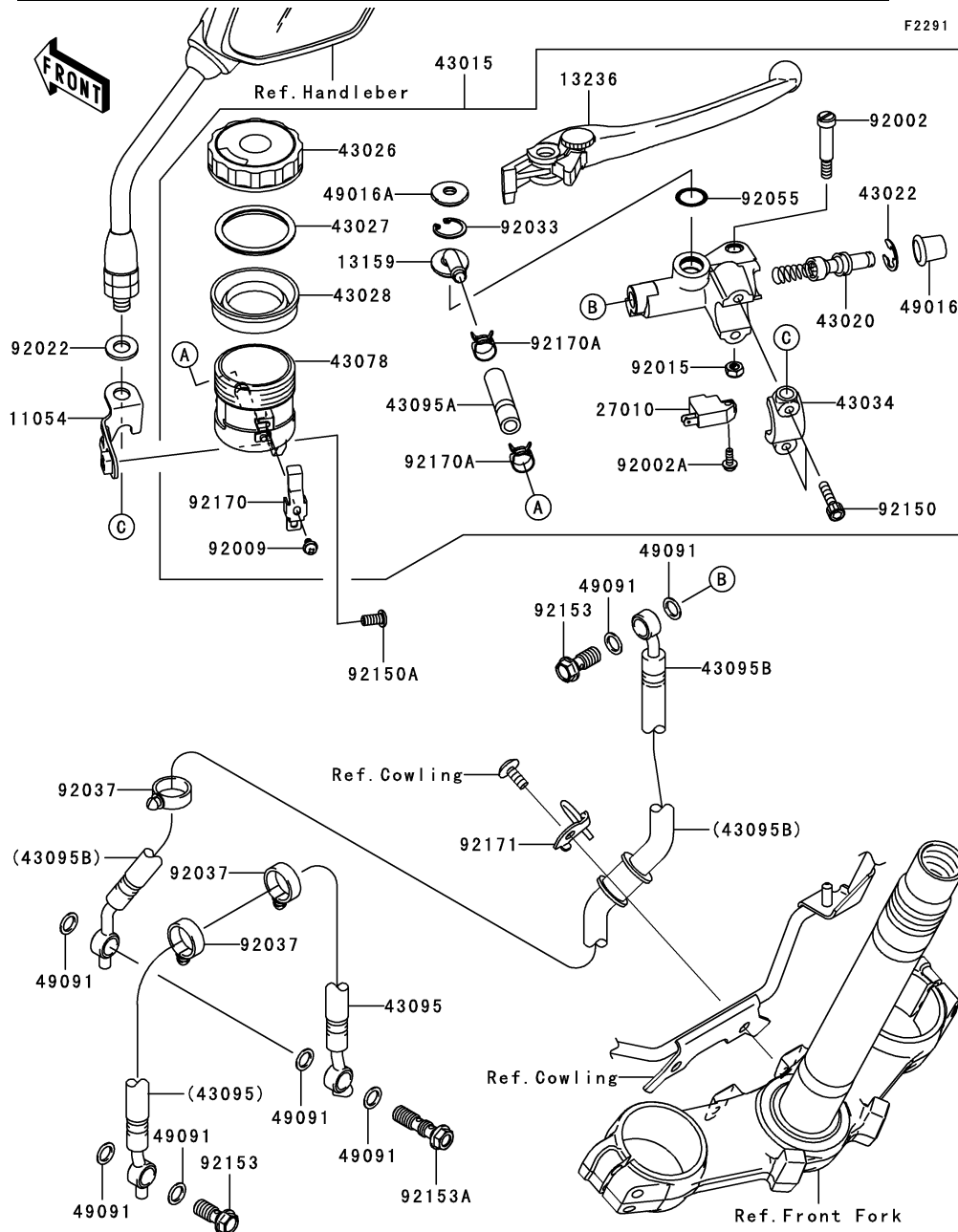

Ref. No.	Part No.	Description	Spec Code	Quantity-ZR750			
				'07	'08		
				L7F	L8F		
11054	11054-1909	BRACKET,RESERVOIR TANK,FR	1	1			
13159	13159-1061	CONNECTOR	1	1			
13236	13236-0140	LEVER-COMP,FRONT BRAKE	1	1			
27010	27010-0025	SWITCH,BRAKE	1	1			
43015	43015-0105	CYLINDER-ASSY-MASTER,FR	1	1			
43020	43020-0008	PISTON-COMP-BRAKE	1	1			
43022	43022-1010	STOPPER-BRAKE,PISTON	1	1			
43026	43026-1051	CAP-BRAKE	1	1			
43027	43027-1051	PLATE-DIAPHRAGM	1	1			
43028	43028-1057	DIAPHRAGM,MASTER CYLINDER	1	1			
43034	43034-1163	HOLDER-BRAKE,MASTER CYLINDER	1	1			
43078	43078-1099	RESERVOIR	1	1			
43095	43095-0363	HOSE-BRAKE,FR	1	1			
43095A	43095-0366	HOSE-BRAKE,FR MASTER CYLINDER	1	1			
43095B	43095-0370	HOSE-BRAKE,FR	1	1			
49016	49016-1044	COVER-SEAL,MASTER CYLINDER	1	1			
49016A	49016-1147	COVER-SEAL	1	1			
49091	49091-0001	WASHER-SEAL,10.1X14.5X1.5	7	7			
92002	92002-1322	BOLT,LEVER SET,BLACK	1	1			
92002A	92002-1323	BOLT,SCREW,4X12	1	1			
92009	92009-1570	SCREW	1	1			
92015	92015-1233	NUT,FLANGED,6MM,BLACK	1	1			
92022	92022-3742	WASHER,10.2X20X1.5	1	1			
92033	92033-1186	RING-SNAP,20.5MM	1	1			
92037	92037-1827	CLAMP,HOSE	3	3			
92055	92055-1251	RING-O,MASTER CYLINDER	1	1			
92150	92150-1328	BOLT	2	2			
92150A	92150-1836	BOLT,SOCKET,6X14	1	1			
92153	92153-1419	BOLT,OIL,L=23	2	2			
92153A	92153-1438	BOLT,OIL,L=37	1	1			
92170	92170-1090	CLAMP	1	1			
92170A	92170-1091	CLAMP,HOSE	2	2			
92171	92171-1667	CLAMP,BRAKE HOSE	1	1			

This catalog covers:

'07~'08 ZR750 L7F/L8F Chassis

GRID NO.

F-6

This grid covers:

Front Brake

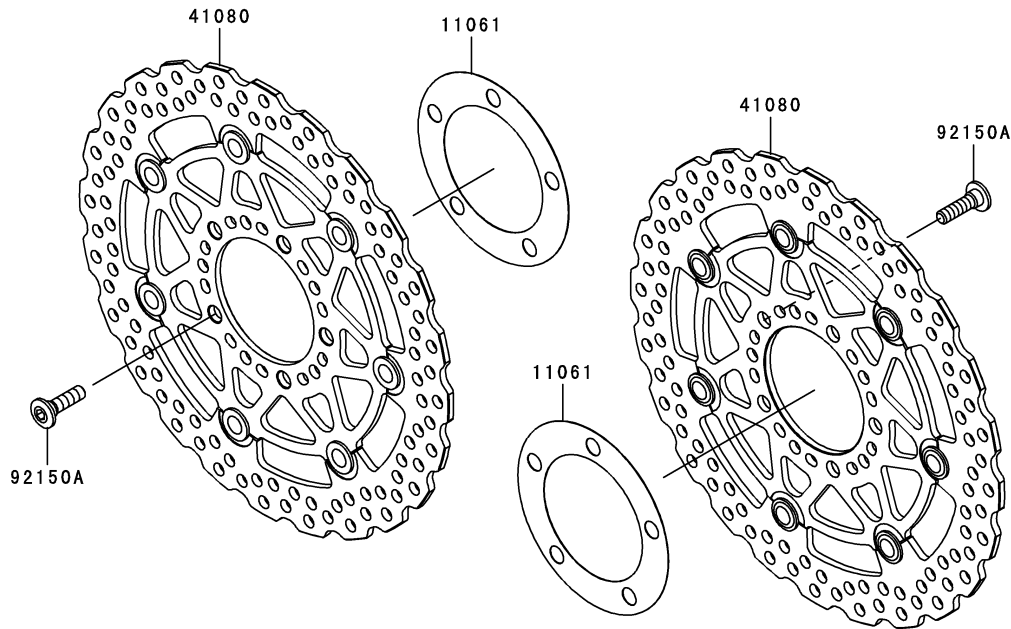
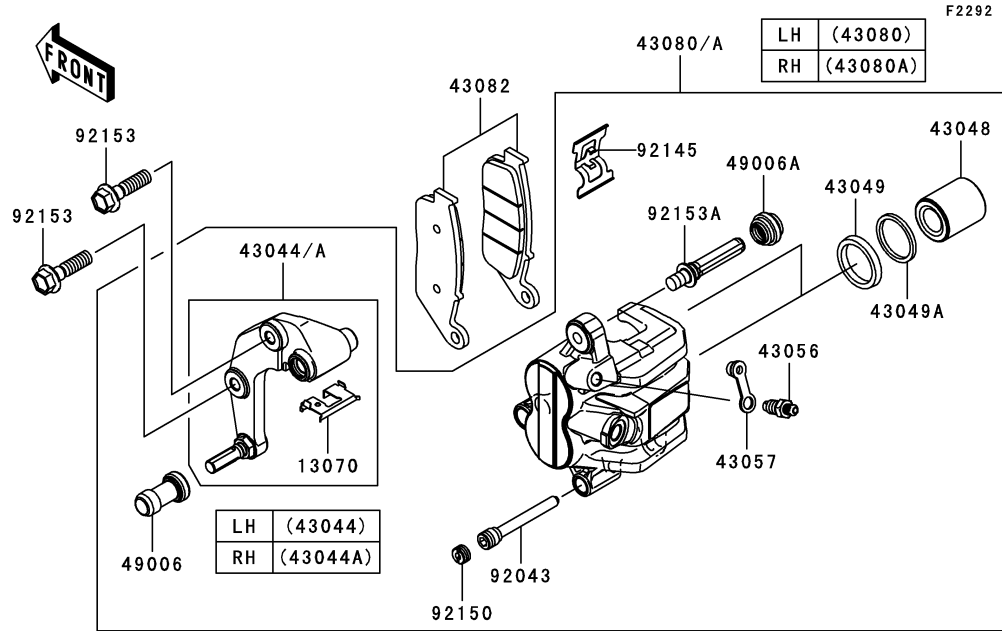

Ref. No.	Part No.	Description	Spec Code	Quantity-ZR750			
				'07	'08		
				L7F	L8F		
11061	11061-0029	GASKET,DISC PLATE	2	2			
13070	13070-0077	GUIDE,BRAKE PAD	2	2			
41080	41080-0103-111	DISC,FR,BLACK+DISC SILVER	2	2			
43044	43044-0024	HOLDER-COMP-CALIPER,FR,LH	1	1			
43044A	43044-0025	HOLDER-COMP-CALIPER,FR,RH	1	1			
43048	43048-1068	PISTON-CALIPER	4	4			
43049	43049-1060	PACKING,PISTON SEAL	4	4			
43049A	43049-1061	PACKING,PISTON SEAL	4	4			
43056	43056-1055	BREATHER	2	2			
43057	43057-1001	CAP-BREATHER	2	2			
43080	43080-0054-DJ	CALIPER-SUB-ASSY,FR,LH,BLACK	1	1			
43080A	43080-0055-DJ	CALIPER-SUB-ASSY,FR,RH,BLACK	1	1			
43082	43082-0079	PAD-ASSY-BRAKE	2	2			
49006	49006-1088	BOOT,CALIPER	2	2			
49006A	49006-1242	BOOT,CALIPER	2	2			
92043	92043-1520	PIN,HANGER	2	2			
92145	92145-0524	SPRING,PAD	2	2			
92150	92150-1692	BOLT,PLUG	2	2			
92150A	92150-1771	BOLT,SOCKET,8X30	10	10			
92153	92153-1089	BOLT,FLANGED,8X30	4	4			
92153A	92153-1872	BOLT	2	2			

This catalog covers:

'07~'08 ZR750 L7F/L8F Chassis

GRID NO.

F-7

This grid covers:

Rear Master Cylinder

F2293

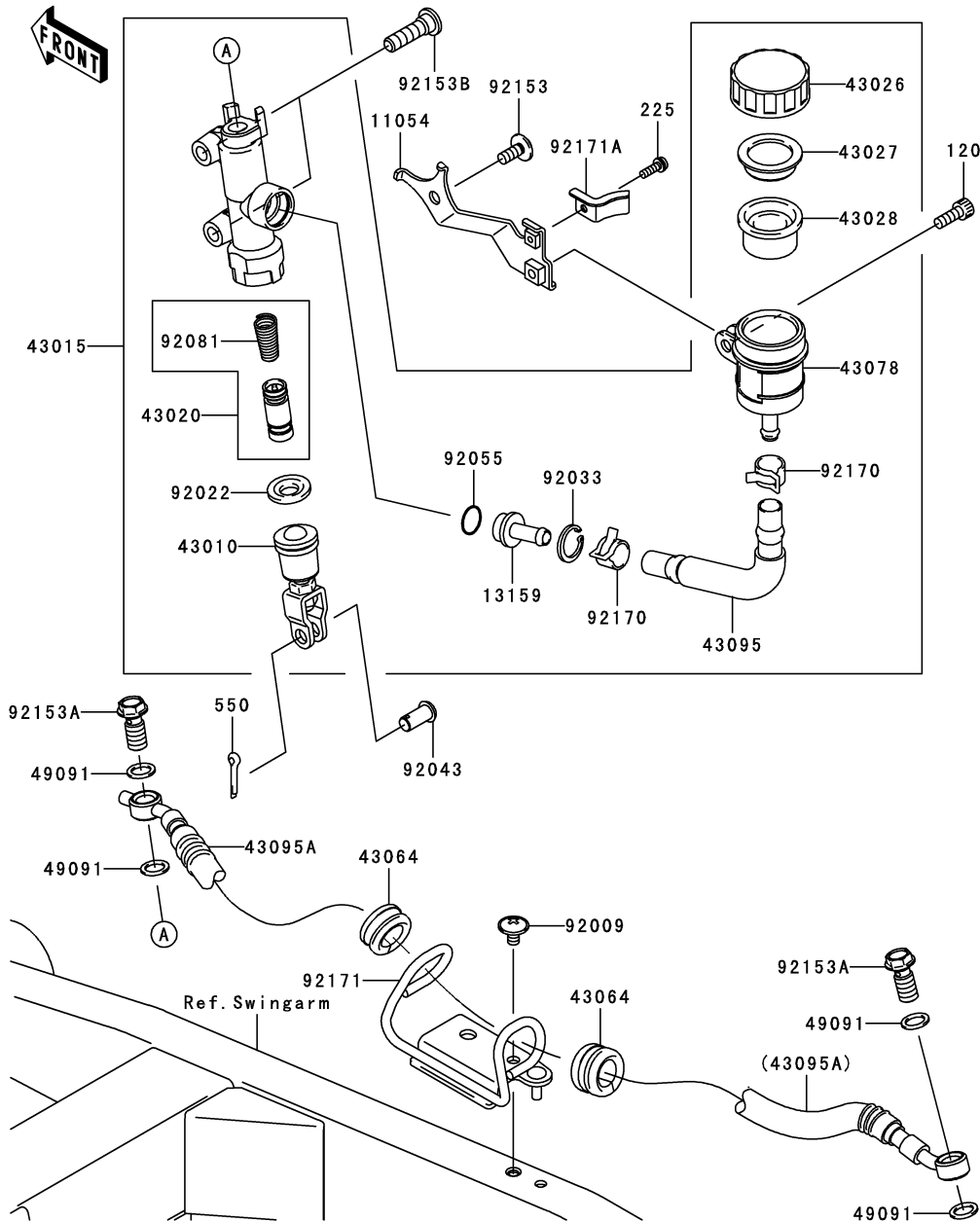

Ref. No.	Part No.	Description	Spec Code	Quantity-ZR750			
				'07	'08		
				L7F	L8F		
11054	11054-1887	BRACKET,RESERVOIR TANK,RR	1	1			
13159	13159-1065	CONNECTOR	1	1			
43010	43010-1062	ROD-ASSY-BRAKE	1	1			
43015	43015-0083	CYLINDER-ASSY-MASTER,RR	1	1			
43020	43020-1057	PISTON-COMP-BRAKE	1	1			
43026	43026-0009	CAP-BRAKE	1	1			
43027	43027-1053	PLATE-DIAPHRAGM	1	1			
43028	43028-1065	DIAPHRAGM	1	1			
43064	43064-007	GROMMET,HOSE CLAMP	2	2			
43078	43078-0040	RESERVOIR	1	1			
43095	43095-0342	HOSE-BRAKE,RR MASTER CYLINDER	1	1			
43095A	43095-0371	HOSE-BRAKE,RR	1	1			
49091	49091-0001	WASHER-SEAL,10.1X14.5X1.5	4	4			
92009	92009-1661	SCREW,6X10	1	1			
92022	92022-1601	WASHER,CIRCRIP	1	1			
92033	92033-1186	RING-SNAP,20.5MM	1	1			
92043	92043-0104	PIN,8X17	1	1			
92055	92055-1251	RING-O,MASTER CYLINDER	1	1			
92081	92081-1737	SPRING,MASTER CYLINDER	1	1			
92153	92153-1361	BOLT,SOCKET,6X14	1	1			
92153A	92153-1419	BOLT,OIL,L=23	2	2			
92153B	92153-1624	BOLT,SOCKET,8X30	2	2			
92170	92170-1091	CLAMP,HOSE	2	2			
92171	92171-0489	CLAMP,BRAKE HOSE	1	1			
92171A	92171-0776	CLAMP,RESERVOIR TANK	1	1			
120	120CA0616	BOLT-SOCKET,6X16	1	1			
225	225F0412	SCREW-PAN-WSP-CROS,4X12	1	1			
550	550AA2015	PIN-COTTER,2.0X15	1	1			

This catalog covers:

'07~'08 ZR750 L7F/L8F Chassis

GRID NO.

F-8

This grid covers:

Rear Brake

F2294

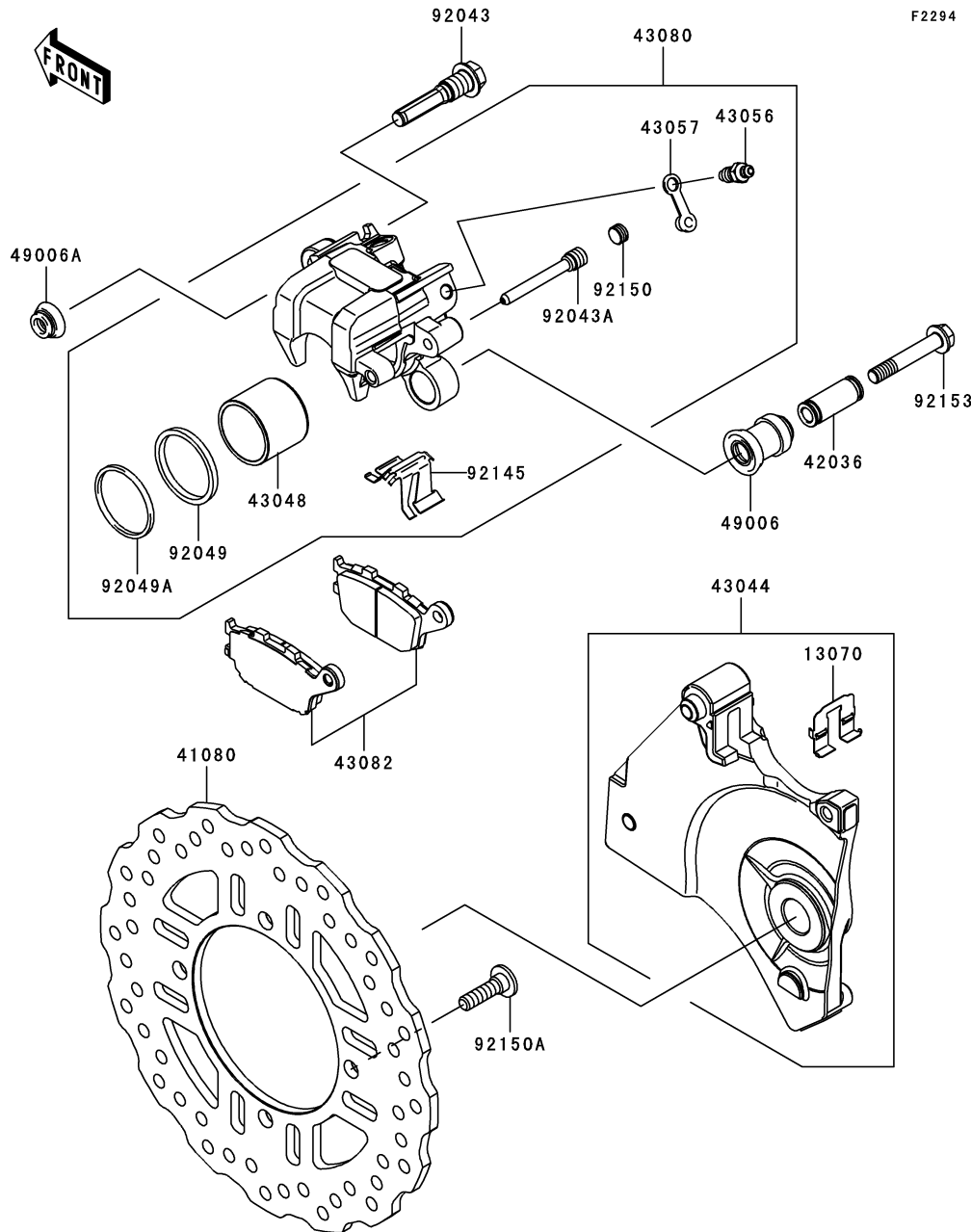

Ref. No.	Part No.	Description	Quantity-ZR750			
			'07	'08		
			L7F	L8F		
13070	13070-0076	GUIDE,BRAKE PAD	1	1		
41080	41080-0089	DISC,RR	1	1		
42036	42036-0050	SLEEVE	1	1		
43044	43044-0014	HOLDER-COMP-CALIPER,RR	1	1		
43048	43048-0008	PISTON-CALIPER	1	1		
43056	43056-1055	BREATHER	1	1		
43057	43057-1001	CAP-BREATHER	1	1		
43080	43080-0050-DJ	CALIPER-SUB-ASSY,RR,BLACK	1	1		
43082	43082-0073	PAD-ASSY-BRAKE	1	1		
49006	49006-0058	BOOT	1	1		
49006A	49006-1242	BOOT,CALIPER	1	1		
92043	92043-0137	PIN	1	1		
92043A	92043-1520	PIN,HANGER	1	1		
92049	92049-1449	SEAL-OIL	1	1		
92049A	92049-1450	SEAL-OIL	1	1		
92145	92145-0493	SPRING,PAD	1	1		
92150	92150-1692	BOLT,PLUG	1	1		
92150A	92150-1771	BOLT,SOCKET,8X30	4	4		
92153	92153-1826	BOLT,FLANGED	1	1		

This catalog covers:

'07~'08 ZR750 L7F/L8F Chassis

GRID NO.

F-9

This grid covers:

Handlebar

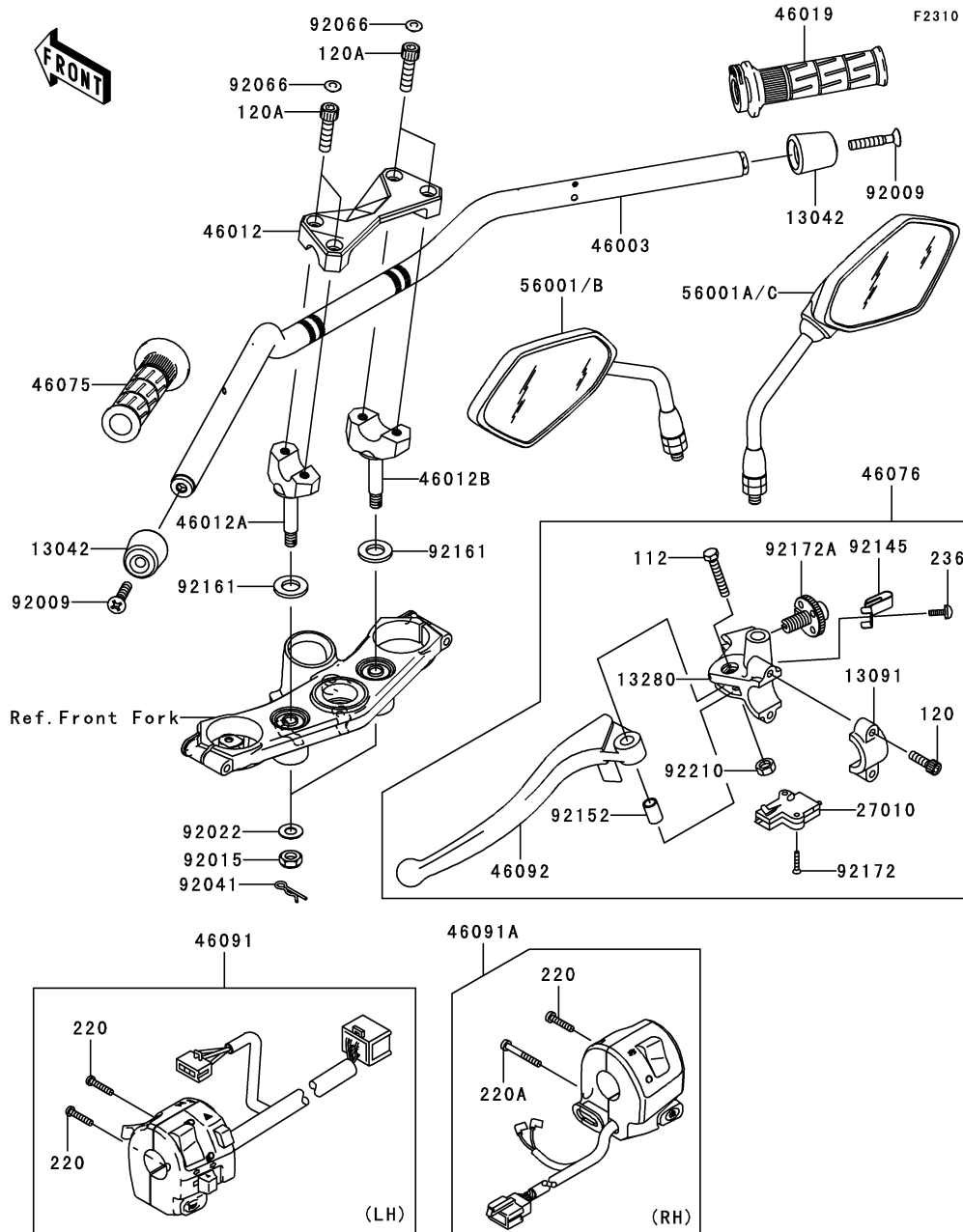

Ref. No.	Part No.	Description	Spec Code	Quantity-ZR750			
				'07	'08		
				L7F	L8F		
13042	13042-1005	WEIGHT,HANDLE	2	2			
13091	13091-1624	HOLDER,CLUTCH LEVER	1	1			
13280	13280-0017	HOLDER,CLUTCH LEVER	1	1			
27010	27010-1094	SWITCH,CLUTCH,BLACK	1	1			
46003	46003-0139-4P	HANDLE,M.F.GRAYSTONE	1	1			
46012	46012-1338	HOLDER-HANDLE,UPP	1	1			
46012A	46012-1339	HOLDER-HANDLE,LWR,LH	1	1			
46012B	46012-1340	HOLDER-HANDLE,LWR,RH	1	1			
46019	46019-0001	GRIP-ASSY,THROTTLE	1	1			
46075	46075-1144	GRIP,LH	1	1			
46076	46076-0005	LEVER-ASSY-GRIP,CLUTCH	1	1			
46091	46091-0118	HOUSING-ASSY-CONTROL,LH	1	1			
46091A	46091-1891	HOUSING-ASSY-CONTROL,RH	1	1			
46092	46092-0003	LEVER-GRIP,CLUTCH	1	1			
56001	56001-0053	MIRROR-ASSY,LH	1				
56001A	56001-0054	MIRROR-ASSY,RH	1				
56001B	56001-0117	MIRROR-ASSY,LH		1			
56001C	56001-0118	MIRROR-ASSY,RH		1			
92009	92009-1257	SCREW,8X45	2	2			
92015	92015-1962	NUT,LOCK,10MM	2	2			
92022	92022-1088	WASHER,10.2X28X2	2	2			
92041	92041-1060	COTTER,8MM	2	2			
92066	92066-1216	PLUG	4	4			
92145	92145-1286	SPRING	1	1			
92152	92152-0103	COLLAR	1	1			
92161	92161-0037	DAMPER	2	2			
92172	92172-0183	SCREW,3X16	2	2			
92172A	92172-1060	SCREW,ADJUST NUT	1	1			
92210	92210-0006	NUT,LOCK,6MM	1	1			
112	112J0630	BOLT-UPSET,6X30	1	1			
120	120S0620	BOLT-SOCKET,6X20	2	2			
120A	120S0830	BOLT-SOCKET,8X30	4	4			
220	220C0525	SCREW-PAN-CROS,5X25	3	3			
220A	220C0540	SCREW-PAN-CROS,5X40	1	1			
236	236C0410	SCREW-PAN-WSP-CROS,4X10	1	1			

This catalog covers:

'07~'08 ZR750 L7F/L8F Chassis

GRID NO.

F-10

This grid covers:

Front Fork

F2340

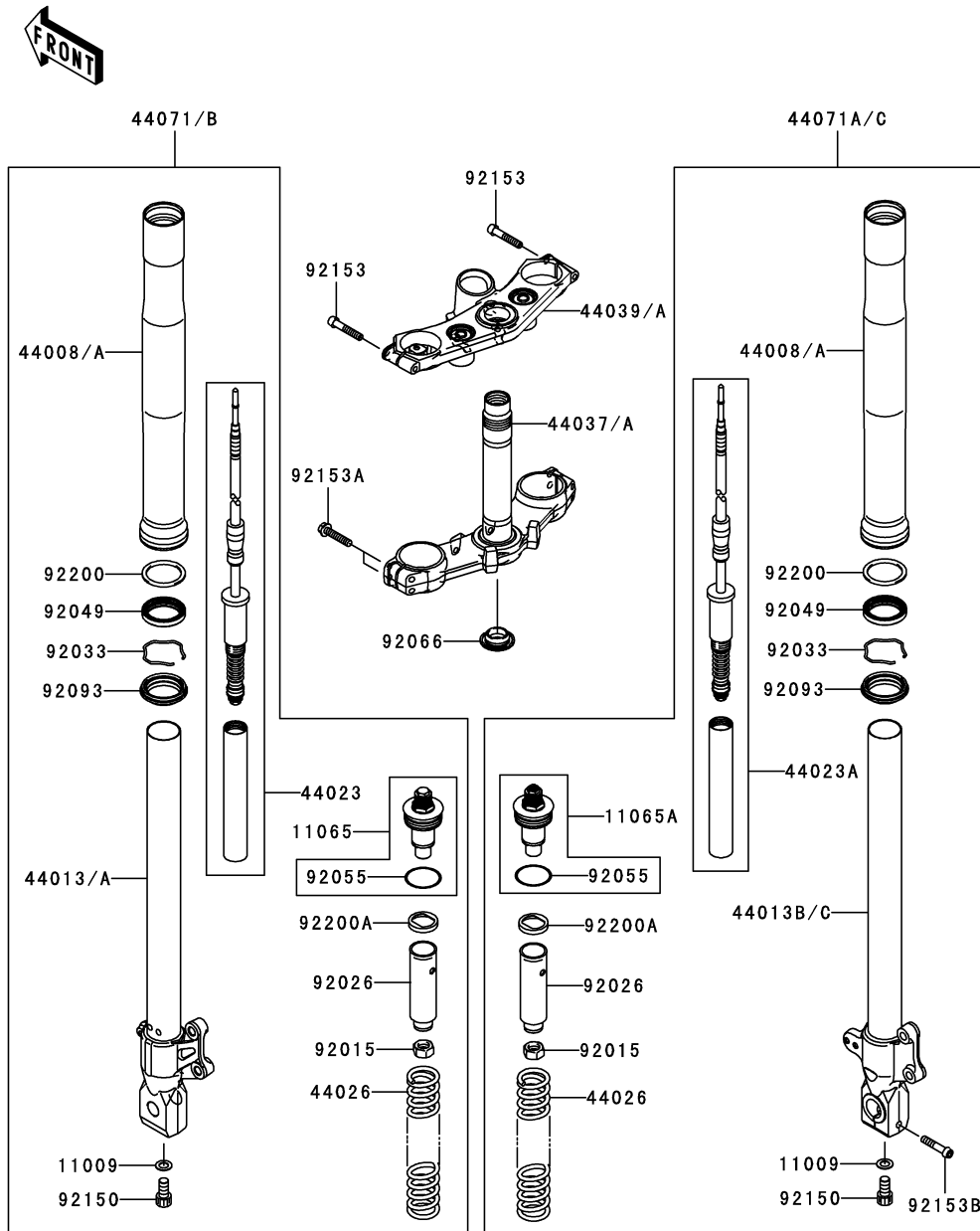

Ref. No.	Part No.	Description	Spec Code	Quantity-ZR750			
				'07	'08		
				L7F	L8F		
11009	11009-1127	GASKET,FORK CYLINDER BOLT	2	2			
11065	11065-0188-499	CAP,FORK BOLT,LH,A.BLACK	1	1			
11065A	11065-0189-499	CAP,FORK BOLT,RH,A.BLACK	1	1			
44008	44008-0030-KX	PIPE-FORK OUTER,SILVER		2			
44008A	44008-0030-499	PIPE-FORK OUTER,A.BLACK	2	2			
44013	44013-0084-18R	PIPE-FORK INNER,LH,BLACK			1		
44013A	44013-0084-21	PIPE-FORK INNER,LH,F.BLACK	1	1			
44013B	44013-0085-18R	PIPE-FORK INNER,RH,BLACK			1		
44013C	44013-0085-21	PIPE-FORK INNER,RH,F.BLACK	1	1			
44023	44023-0053	CYLINDER-SET-FORK,LH	1	1			
44023A	44023-0054	CYLINDER-SET-FORK,RH	1	1			
44026	44026-0102	SPRING-FRONT FORK	2	2			
44037	44037-0066-11E	HOLDER-FORK UNDER,F.S.BLACK	1	1			
44037A	44037-0066-18R	HOLDER-FORK UNDER,BLACK			1		
44039	44039-0057-11E	HOLDER-FORK UPPER,F.S.BLACK	1	1			
44039A	44039-0057-18R	HOLDER-FORK UPPER,BLACK			1		
44071	44071-5044	DAMPER-ASSY,FORK,LH,BLACK	1	1			
44071A	44071-5045	DAMPER-ASSY,FORK,RH,BLACK	1	1			
44071B	44071-5061	DAMPER-ASSY,FORK,LH,SILVER			1		
44071C	44071-5062	DAMPER-ASSY,FORK,RH,SILVER			1		
92015	92015-1795	NUT	2	2			
92026	92026-0045	SPACER,FORK	2	2			
92033	92033-1036	RING-SNAP	2	2			
92049	92049-0073	SEAL-OIL	2	2			
92055	92055-1333	RING-O,FORK,AIR TUBE	2	2			
92066	92066-0032	PLUG	1	1			
92093	92093-1472	SEAL,FORK OUTER TUBE	2	2			
92150	92150-1398	BOLT,12X22	2	2			
92153	92153-0425	BOLT	2	2			
92153A	92153-0484	BOLT,FLANGED,8X40	4	4			
92153B	92153-0506	BOLT,SOCKET,8X40	1	1			
92200	92200-0001	WASHER	2	2			
92200A	92200-0085	WASHER	2	2			

This catalog covers:

'07~'08 ZR750 L7F/L8F Chassis

GRID NO.

F-11

This grid covers:

Fuel Tank

F2410

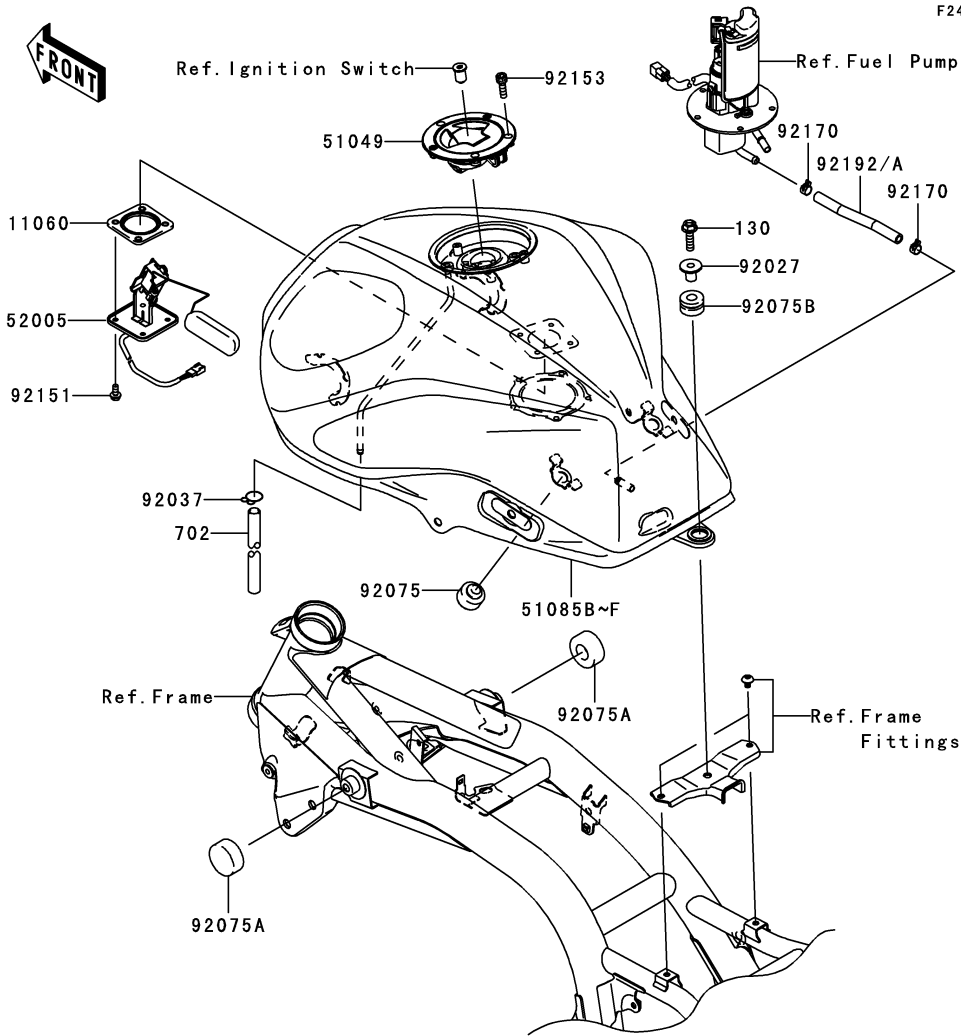

Ref. No.	Part No.	Description	Quantity-ZR750			
			'07	'08		
			L7F	L8F		
11060	11060-1952	GASKET,FUEL GAUGE	1	1		
51049	51049-0012	CAP-TANK,FUEL	1	1		
51085B	51085-5249-H8	TANK-COMP-FUEL,EBONY	1	1		
51085C	51085-5249-17P	TANK-COMP-FUEL,C.L.GREEN	1			
51085D	51085-5249-726	TANK-COMP-FUEL,M.O.BLUE		1		
51085E	51085-5251-17H	TANK-COMP-FUEL,P.ORANGE		1		
51085F	51085-5251-17M	TANK-COMP-FUEL,SILVER	1			
52005	52005-0025	GAUGE,FUEL	1	1		
92027	92027-1780	COLLAR,L=19.3	1	1		
92037	92037-010	CLAMP,TUBE	1	1		
92075	92075-015	DAMPER	2	2		
92075A	92075-101	DAMPER,FUEL TANK	2	2		
92075B	92075-1736	DAMPER	1	1		
92151	92151-1599	BOLT,5X12	4	4		
92153	92153-1616	BOLT,SOCKET,5X16	3	3		
92170	92170-1492	CLAMP	2	2		
92192	92192-0479	TUBE,FUEL	1			
92192A	92192-0593	TUBE,FUEL		1		
130	130G0830	BOLT-FLANGED,8X30	1	1		
702	702A06750	TUBE-RUBBER,6X9X750	1	1		

(51085B)	Ebony
(51085C)	Green
(51085D)	Blue
(51085E)	Orange
(51085F)	Silver

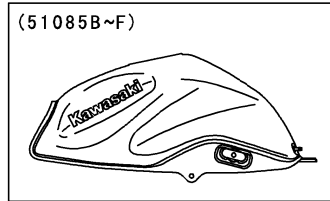

WD

This catalog covers:

'07~'08 ZR750 L7F/L8F Chassis

GRID NO.

F-12

This grid covers:

Seat(1/2)

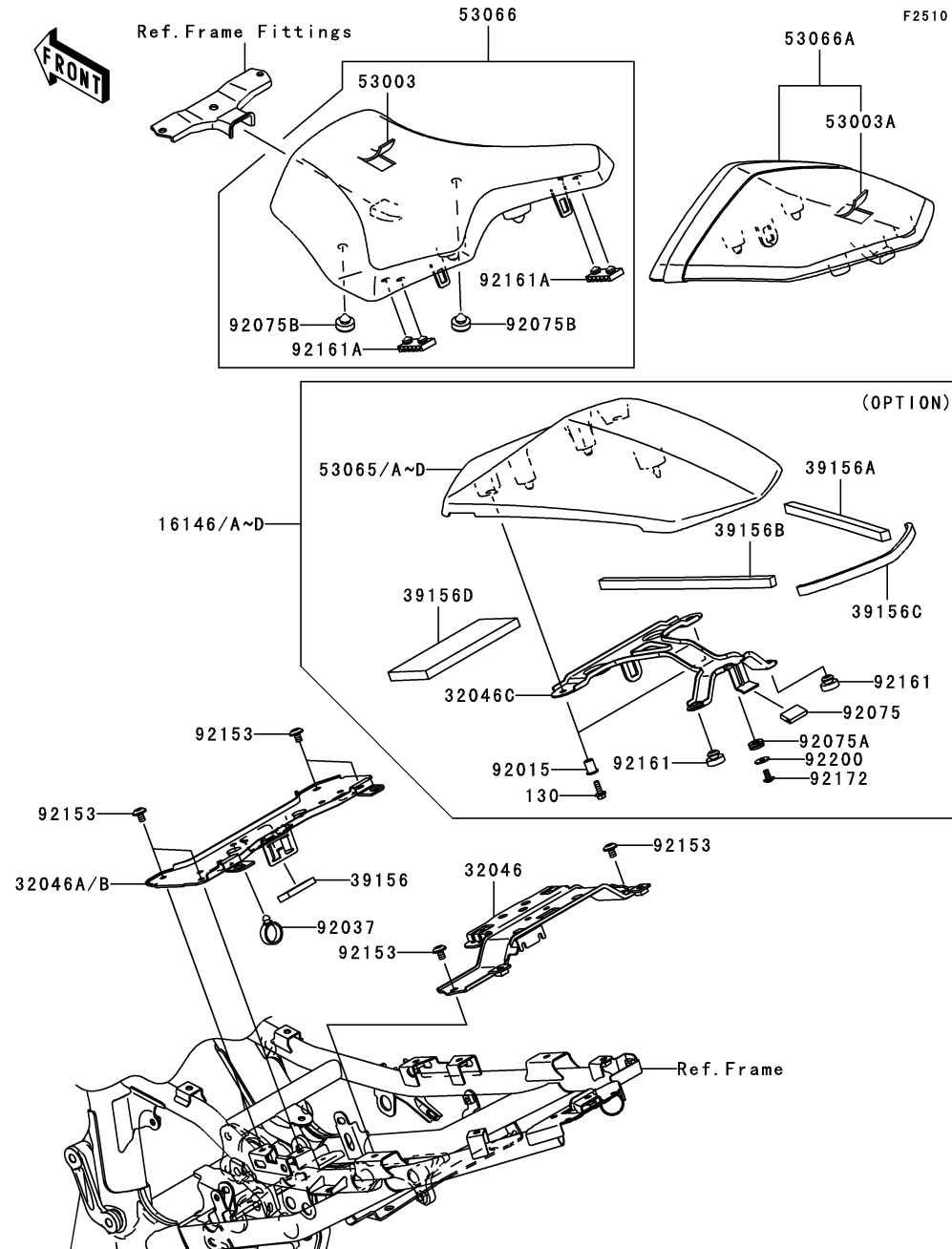

Ref. No.	Part No.	Description	Spec Code	Quantity-ZR750			
				'07	'08		
				L7F	L8F		
16146	16146-0075-H8 (OPTION)	COVER-ASSY,SINGLE SEAT,EBONY		1	1		
16146A	16146-0075-17H (OPTION)	COVER-ASSY,SINGLE SEAT,ORANGE			1		
16146B	16146-0075-17M (OPTION)	COVER-ASSY,SINGLE SEAT,SILVER		1			
16146C	16146-0075-17P (OPTION)	COVER-ASSY,SINGLE SEAT,GREEN		1			
16146D	16146-0075-726 (OPTION)	COVER-ASSY,SINGLE SEAT,BLUE			1		
32046	32046-0114	BRACKET-SEAT,RR		1	1		
32046A	32046-0117	BRACKET-SEAT,FR		1			
32046B	32046-0118	BRACKET-SEAT,FR			1		
32046C	32046-0120 (OPTION)	BRACKET-SEAT		1	1		
39156	39156-0320	PAD		1	1		
39156A	39156-0415 (OPTION)	PAD,SEAT COVER,RH		1	1		
39156B	39156-0416 (OPTION)	PAD,SEAT COVER,LH		1	1		
39156C	39156-0417 (OPTION)	PAD,SEAT COVER,RR		1	1		
39156D	39156-0419 (OPTION)	PAD,SEAT COVER,FR		1	1		
53003	53003-0095-MA	LEATHER,FRONT SEAT,BLACK		1	1		
53003A	53003-0096-MA	LEATHER,REAR SEAT,BLACK		1	1		
53065	53065-0015-H8 (OPTION)	COVER SEAT,EBONY		1	1		
53065A	53065-0015-17H (OPTION)	COVER SEAT,P.ORANGE			1		
53065B	53065-0015-17M (OPTION)	COVER SEAT,SILVER		1			
53065C	53065-0015-17P (OPTION)	COVER SEAT,C.L.GREEN		1			
53065D	53065-0015-726 (OPTION)	COVER SEAT,M.O.BLUE			1		
53066	53066-0138-MA	SEAT-ASSY,FR,BLACK		1	1		
53066A	53066-0139-12Y	SEAT,RR,LEATHER BLK+BAND BLK		1	1		
92015	92015-1757 (OPTION)	NUT,WELL,5MM		2	2		
92037	92037-1827	CLAMP,HOSE		1	1		
92075	92075-1446 (OPTION)	DAMPER		1	1		

This catalog covers:

'07~'08 ZR750 L7F/L8F Chassis

GRID NO.

F-13

This grid covers:

Seat(2/2)

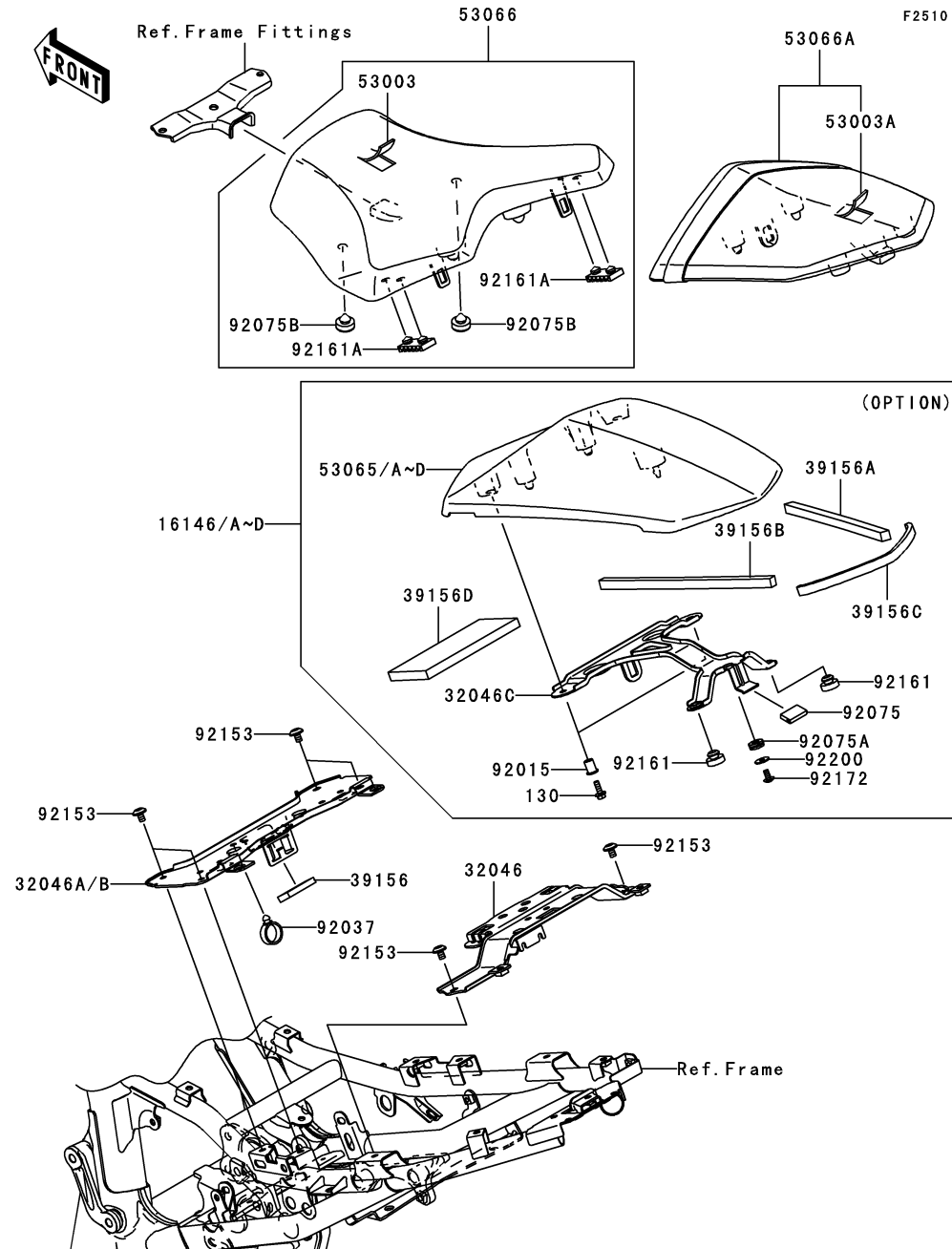

Ref. No.	Part No.	Description	Spec Code	Quantity-ZR750			
				'07	'08		
				L7F	L8F		
92075A	92075-161 (OPTION)	DAMPER		1	1		
92075B	92075-1927	DAMPER		2	2		
92153	92153-1612	BOLT, SOCKET, 6X14		6	6		
92161	92161-0046 (OPTION)	DAMPER		2	2		
92161A	92161-0149	DAMPER, SEAT		2	2		
92172	92172-1061 (OPTION)	SCREW, TAPPING, 5X10		1	1		
92200	92200-0288 (OPTION)	WASHER		1	1		
130	130BA0514 (OPTION)	BOLT-FLANGED, 5X14		2	2		

This catalog covers:

'07~'08 ZR750 L7F/L8F Chassis

GRID NO.

F-14

This grid covers:

Meter(s)

F2530

Ref. No.	Part No.	Description	Spec Code	Quantity-ZR750			
				'07	'08		
				L7F	L8F		
14091	14091-0711	COVER,METER,LWR		1	1		
25023	25023-0027	COVER-METER CASE,UPP		1	1		
25031	25031-0145	METER-ASSY,TACHO&LCD		1	1		
28011	28011-0076	METER,TACHO&LCD		1	1		
39156	39156-0344	PAD		1	1		
92009	92009-1164	SCREW,TAPPING,3X16		9	9		
92009A	92009-1197	SCREW,TAPPING,5X14		3	3		
92022	92022-1405	WASHER,5.5X20X1.2		3	3		
92160	92160-1167	DAMPER		3	3		

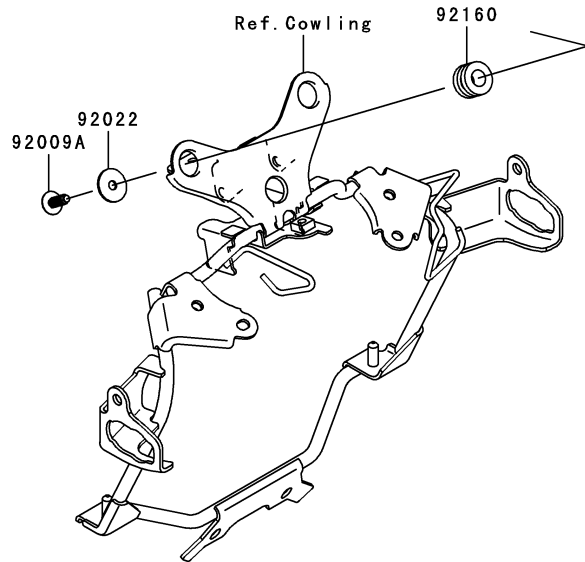
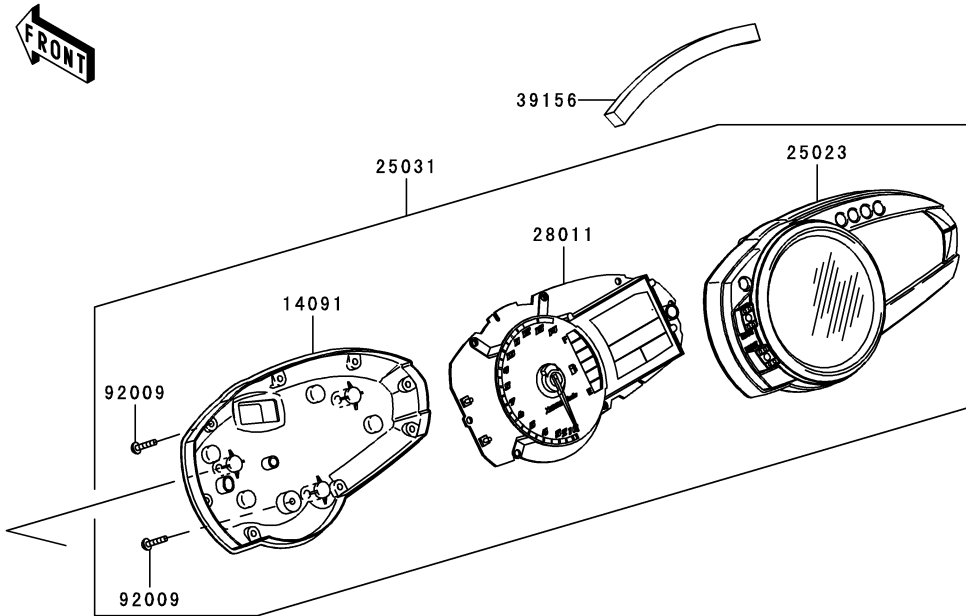

This catalog covers:

'07~'08 ZR750 L7F/L8F Chassis

GRID NO.

G-3

This grid covers:

Cables

F2540

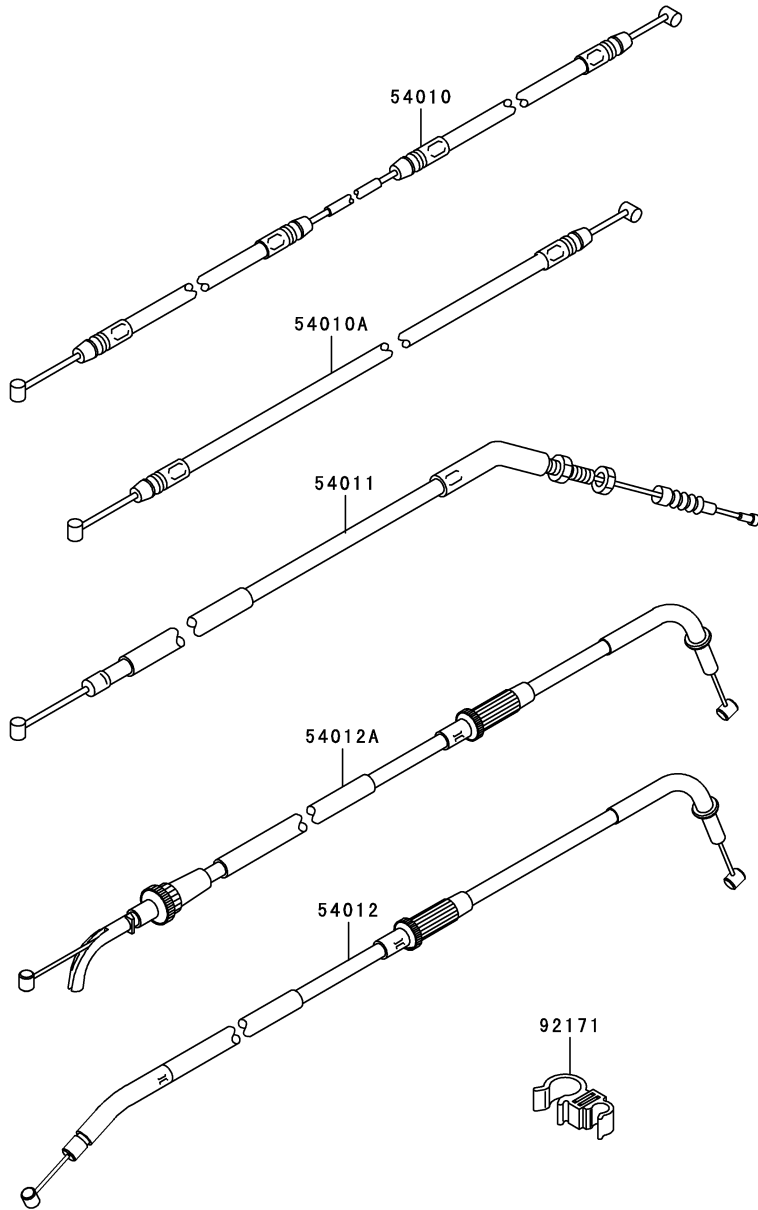

Ref. No.	Part No.	Description	Quantity-ZR750			
			'07	'08		
			L7F	L8F		
54010	54010-0047	CABLE,SEAT LOCK,FR	1	1		
54010A	54010-0048	CABLE,SEAT LOCK,RR	1	1		
54011	54011-1424	CABLE-CLUTCH	1	1		
54012	54012-0068	CABLE-THROTTLE,CLOSING	1	1		
54012A	54012-0118	CABLE-THROTTLE,OPENING	1	1		
92171	92171-1666	CLAMP	1	1		

This catalog covers:

'07~'08 ZR750 L7F/L8F Chassis

GRID NO.

G-4

This grid covers:

Side Covers/Chain Cover

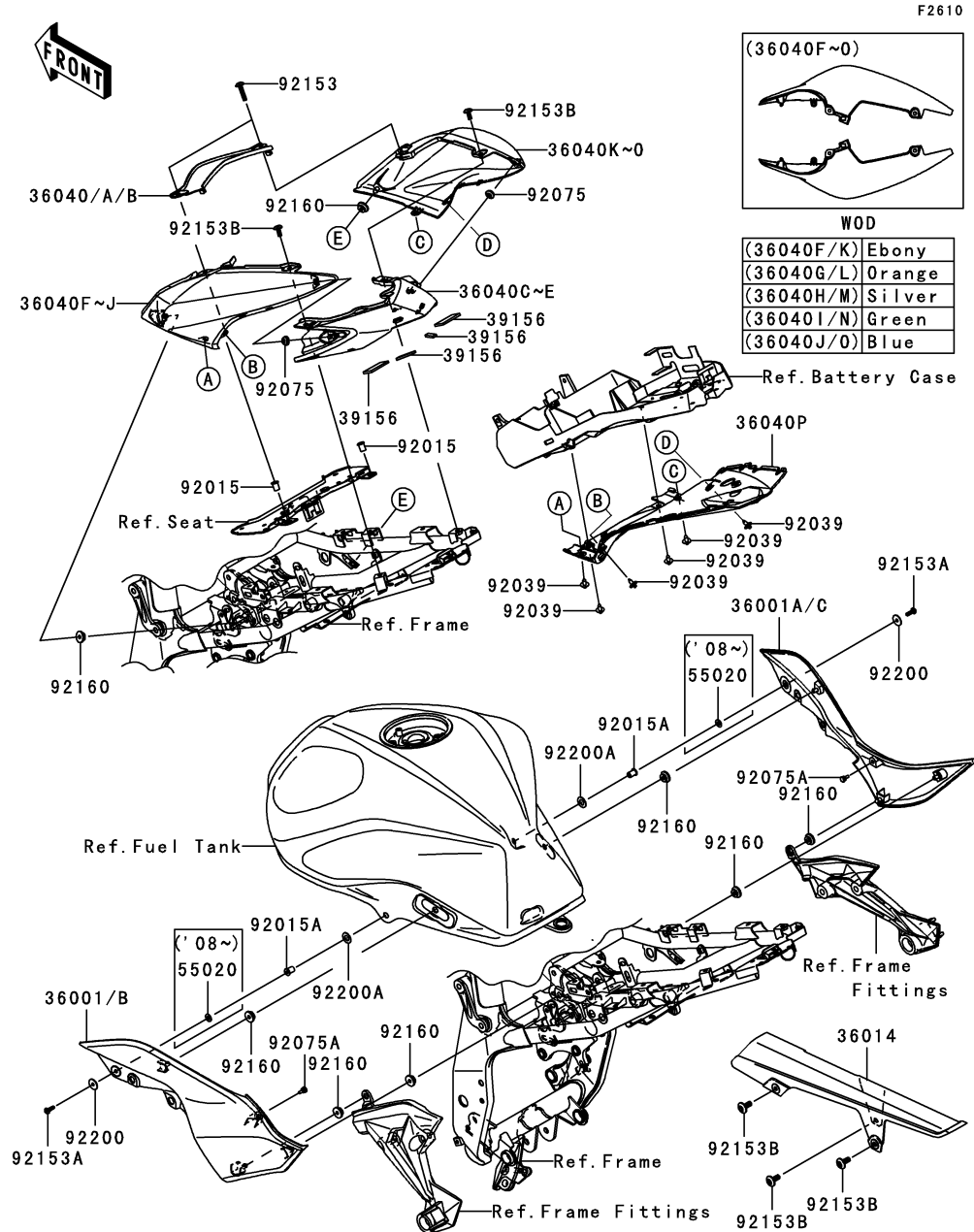

Ref. No.	Part No.	Description	Spec Code	Quantity-ZR750			
				'07	'08		
				L7F	L8F		
36001	36001-0108-6Z	COVER-SIDE,LH,F,BLACK		1			
36001A	36001-0109-6Z	COVER-SIDE,RH,F,BLACK		1			
36001B	36001-0135-6Z	COVER-SIDE,LH,F,BLACK			1		
36001C	36001-0136-6Z	COVER-SIDE,RH,F,BLACK			1		
36014	36014-0025	CASE-CHAIN		1	1		
36040	36040-0043-H8	COVER-TAIL,CNT,FR,EBONY		1	1		
36040A	36040-0043-11J	COVER-TAIL,CNT,FR,F.S.BLACK		1			
36040B	36040-0043-18T	COVER-TAIL,CNT,FR,BLACK			1		
36040C	36040-0044-H8	COVER-TAIL,CNT,RR,EBONY		1	1		
36040D	36040-0044-11J	COVER-TAIL,CNT,RR,F.S.BLACK		1			
36040E	36040-0044-18T	COVER-TAIL,CNT,RR,BLACK			1		
36040F	36040-0071-H8	COVER-TAIL,SIDE,LH,EBONY		1	1		
36040G	36040-0071-17H	COVER-TAIL,SIDE,LH,P,ORANGE			1		
36040H	36040-0071-17M	COVER-TAIL,SIDE,LH,SILVER		1			
36040I	36040-0071-17P	COVER-TAIL,SIDE,LH,C.L.GREEN		1			
36040J	36040-0071-726	COVER-TAIL,SIDE,LH,M.O.BLUE				1	
36040K	36040-0072-H8	COVER-TAIL,SIDE,RH,EBONY		1	1		
36040L	36040-0072-17H	COVER-TAIL,SIDE,RH,P,ORANGE				1	
36040M	36040-0072-17M	COVER-TAIL,SIDE,RH,SILVER		1			
36040N	36040-0072-17P	COVER-TAIL,SIDE,RH,C.L.GREEN		1			
36040O	36040-0072-726	COVER-TAIL,SIDE,RH,M.O.BLUE				1	
36040P	36040-0079-6Z	COVER-TAIL,LWR,F,BLACK		1	1		
39156	39156-0286	PAD		4	4		
55020	55020-0398	GUARD			2		
92015	92015-1700	NUT		2	2		
92015A	92015-1757	NUT,WELL,5MM		2	2		
92039	92039-1256	RIVET		6	6		
92075	92075-1011	DAMPER		2	2		
92075A	92075-1808	DAMPER		2	2		
92153	92153-0816	BOLT,6X18		2	2		
92153A	92153-1244	BOLT,SOCKET,5X16		2	2		
92153B	92153-1612	BOLT,SOCKET,6X14		5	5		
92160	92160-1613	DAMPER		8	8		
92200	92200-0284	WASHER,5.5X20X1.2		2	2		
92200A	92200-0414	WASHER,10.3X20X1		2	2		

This catalog covers:

'07~'08 ZR750 L7F/L8F Chassis

GRID NO.

G-5

This grid covers:

Headlight(s)

F2710

Ref. No.	Part No.	Description	Spec Code	Quantity-ZR750			
				'07	'08		
				L7F	L8F		

23007	23007-0079	LENS-COMP,HEAD LAMP	1	1		
23008	23008-0063	SOCKET-ASSY,HEAD LAMP	2	2		
23017	23017-0003	SOCKET,HEAD LAMP	2	2		
49016	49016-0038	COVER-SEAL,HEAD LAMP	2	2		
92022	92022-1405	WASHER,5.5X20X1.2	4	4		
92069	92069-1016	BULB,12V 5W	2	2		
92069A	92069-1126	BULB,12V 55W,H7	2	2		
92160	92160-1613	DAMPER	2	2		
92161	92161-0054	DAMPER	4	4		
92172	92172-0006	SCREW,TAPPING,5X14	4	4		

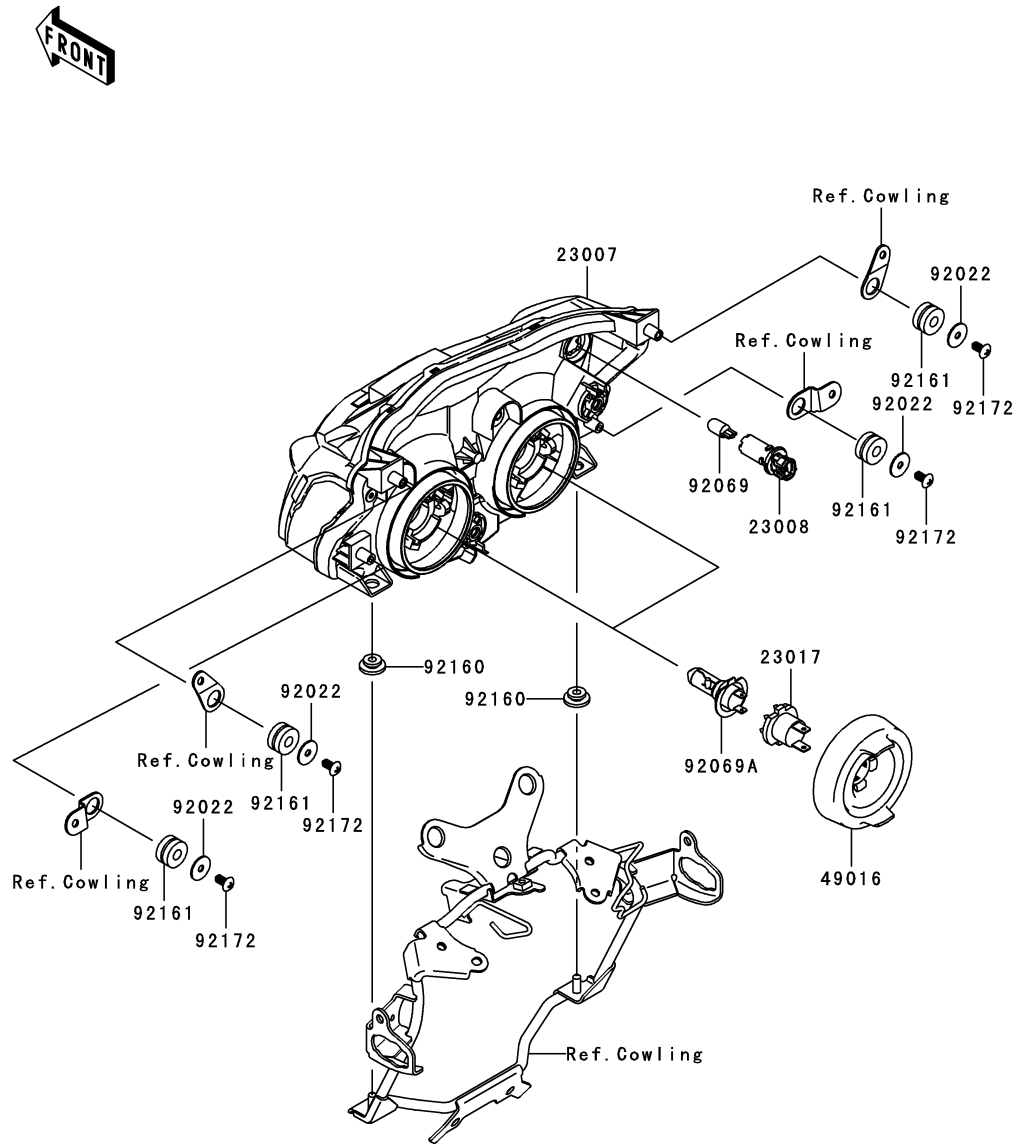

This catalog covers:

'07~'08 ZR750 L7F/L8F Chassis

GRID NO.

G-6

This grid covers:

Taillight(s)

F2720

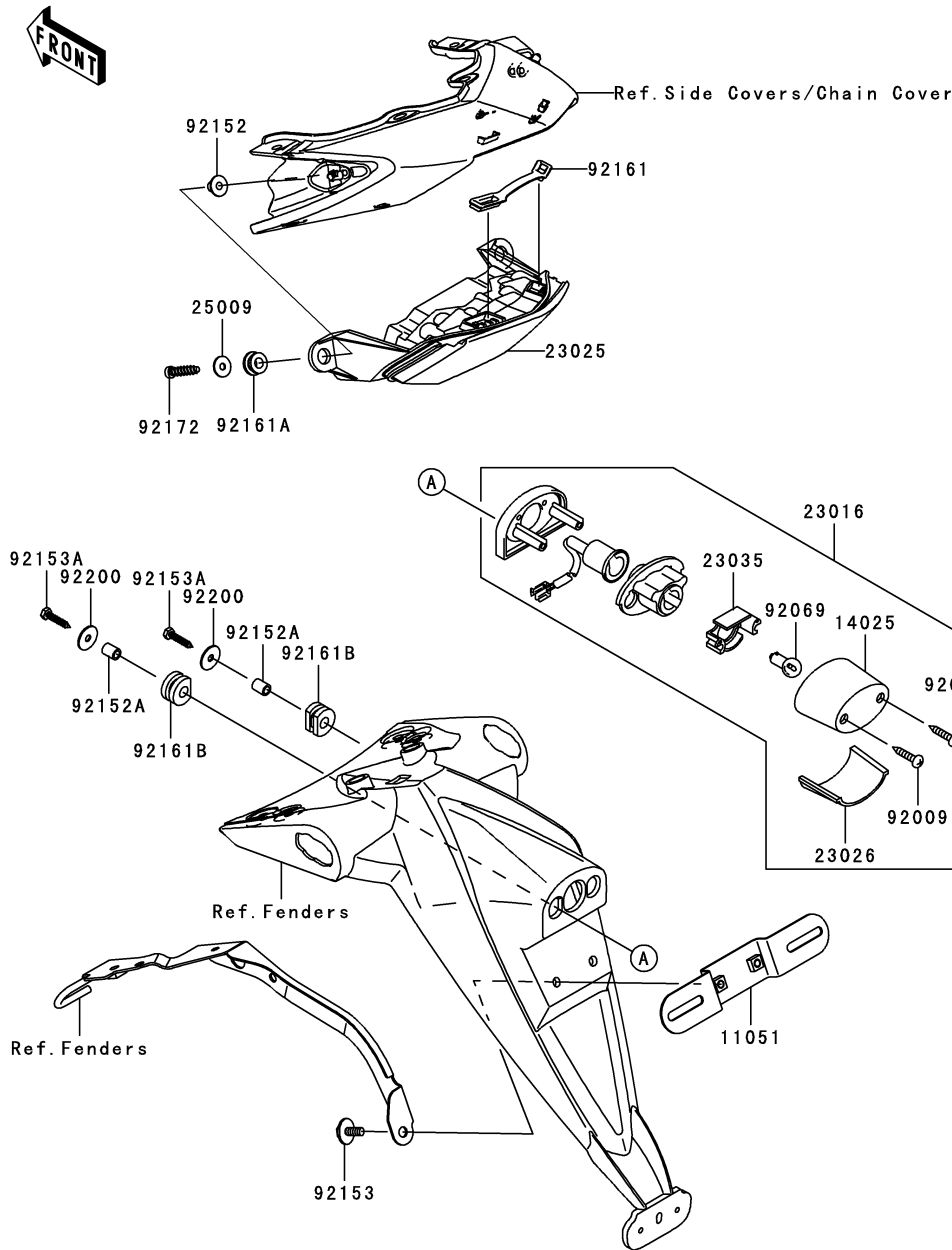

Ref. No.	Part No.	Description	Quantity-ZR750			
			'07	'08		
			L7F	L8F		
11051	11051-1503	BRACKET,LICENSE	1	1		
14025	14025-1725	COVER,LICENSE LAMP	1	1		
23016	23016-1200	LAMP-ASSY,LICENSE	1	1		
23025	23025-0027	LAMP-TAIL	1	1		
23026	23026-1064	LENS,LICENSE LAMP	1	1		
23035	23035-1066	REFLECTOR-LAMP,LICENSE	1	1		
25009	25009-004	WASHER,5.2X16X1.2	2	2		
92009	92009-1378	SCREW,TAPPING,4X20	2	2		
92069	92069-1055	BULB,12V 5W	1	1		
92152	92152-0092	COLLAR	2	2		
92152A	92152-0372	COLLAR,6X9X11.5	2	2		
92153	92153-0684	BOLT,6X16	2	2		
92153A	92153-1424	BOLT,TAPPING,5X25	2	2		
92161	92161-0191	DAMPER,TAIL LAMP	1	1		
92161A	92161-0317	DAMPER	2	2		
92161B	92161-1313	DAMPER	2	2		
92172	92172-0056	SCREW-PAN-CROS,5X25	2	2		
92200	92200-0284	WASHER,5.5X20X1.2	2	2		

This catalog covers:

'07~'08 ZR750 L7F/L8F Chassis

GRID NO.

G-7

This grid covers:

Turn Signals

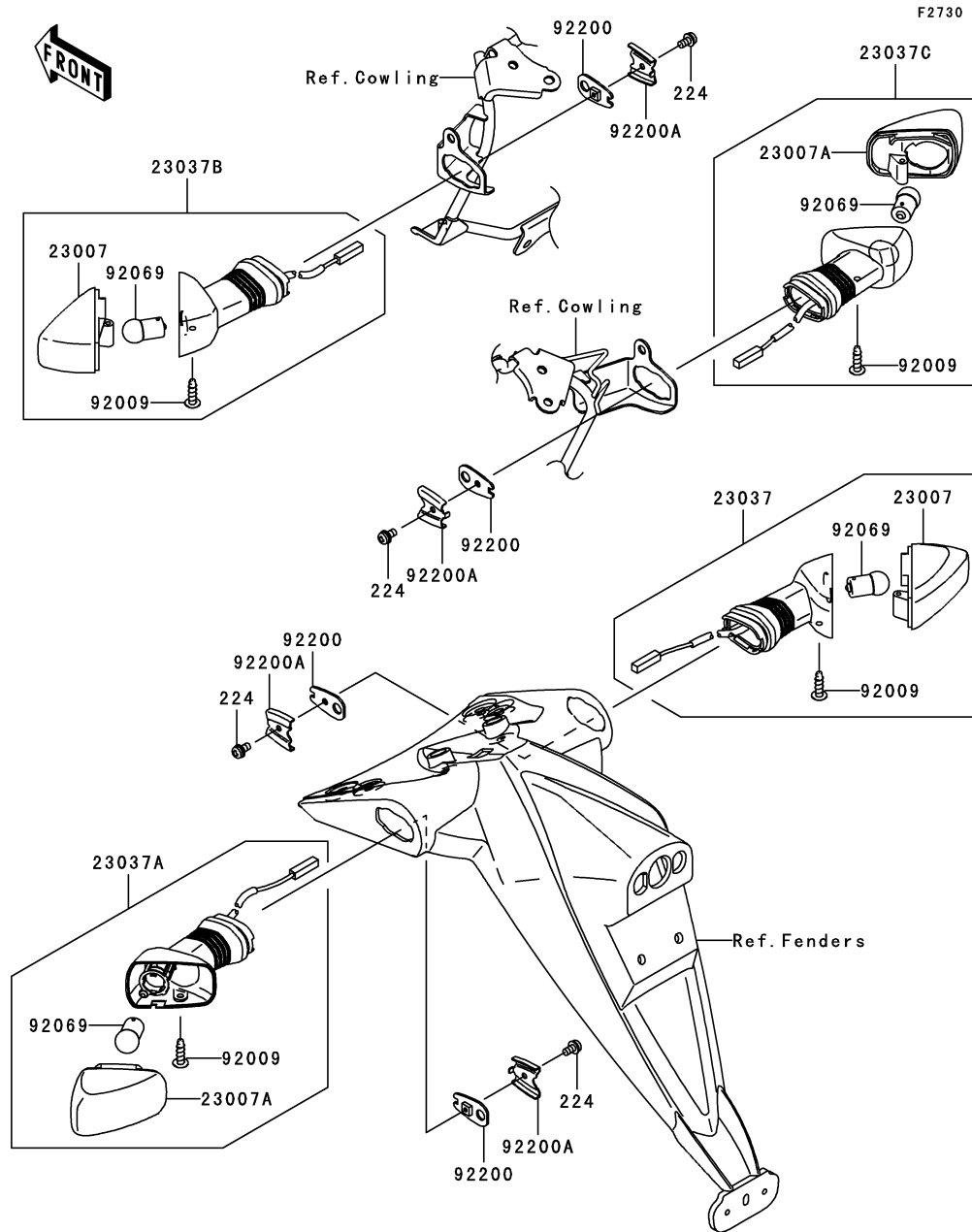

Ref. No.	Part No.	Description	Quantity-ZR750			
			'07	'08		
			L7F	L8F		
23007	23007-0039	LENS-COMP,SIGNAL LAMP	2	2		
23007A	23007-0040	LENS-COMP,SIGNAL LAMP	2	2		
23037	23037-0061	LAMP-ASSY-SIGNAL,RR,RH	1	1		
23037A	23037-0062	LAMP-ASSY-SIGNAL,RR,LH	1	1		
23037B	23037-0068	LAMP-ASSY-SIGNAL,FR,LH	1	1		
23037C	23037-0069	LAMP-ASSY-SIGNAL,FR,RH	1	1		
92009	92009-1158	SCREW,4X16,BLACK	4	4		
92069	92069-0003	BULB,12V 10W	4	4		
92200	92200-0164	WASHER,SIGNAL LAMP	4	4		
92200A	92200-0165	WASHER,SIGNAL LAMP	4	4		
224	224C0408	SCREW-PAN-WP-CROS,4X8	4	4		

This catalog covers:

'07~'08 ZR750 L7F/L8F Chassis

GRID NO.

G-8

This grid covers:

Chassis Electrical Equipment

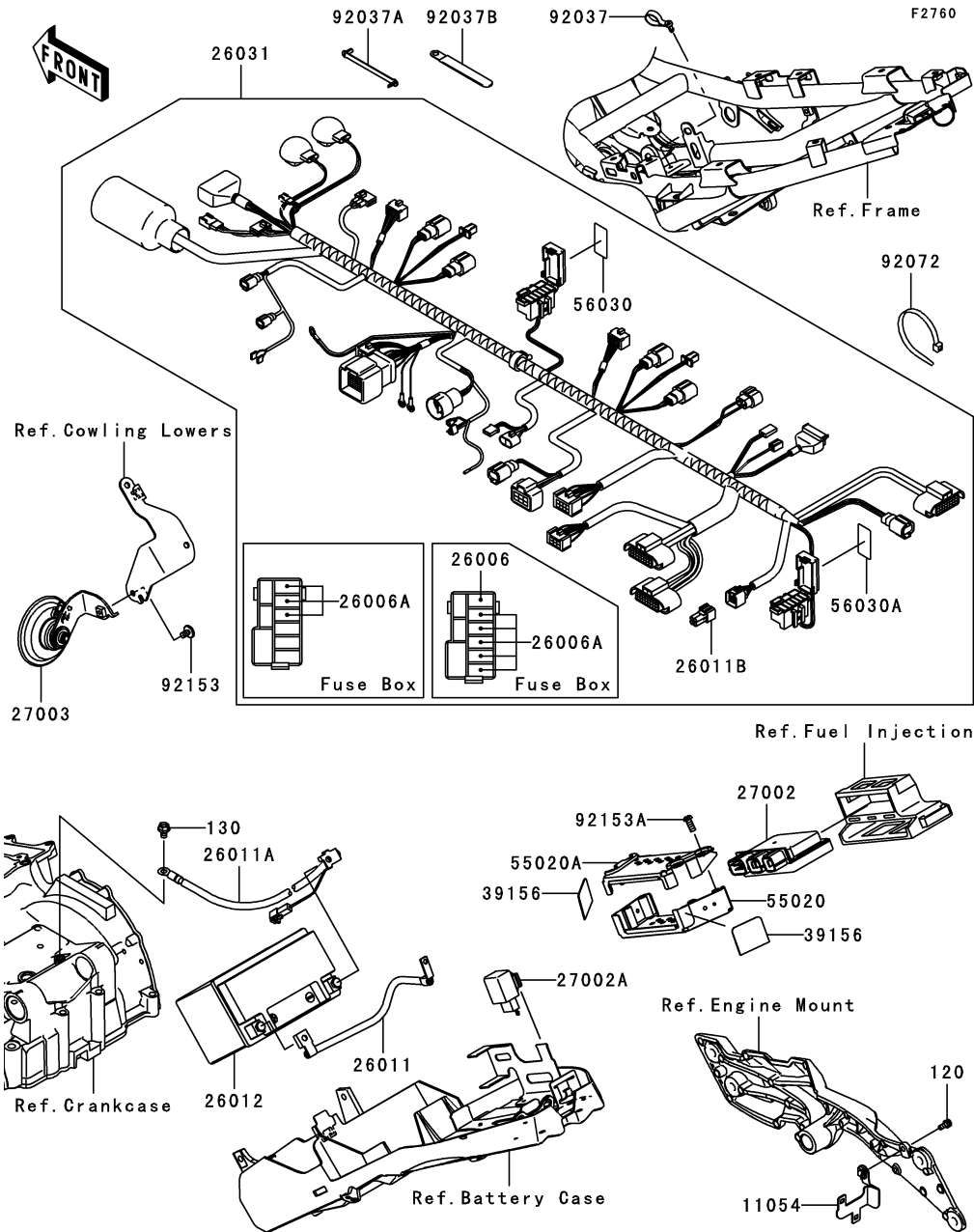

Ref. No.	Part No.	Description	Spec Code	Quantity-ZR750			
				'07	'08		
				L7F	L8F		
11054	11054-1992	BRACKET,COUPLER	1	1			
26006	26006-0001	FUSE,15A	1	1			
26006A	26006-1078	FUSE,10A	8	8			
26011	26011-0107	WIRE-LEAD,BATTERY(+)	1	1			
26011A	26011-0108	WIRE-LEAD,BATTERY(-)	1	1			
26011B	26011-0159	WIRE-LEAD	1	1			
26012	26012-0088	BATTERY,YTX9-BS,12V 8AH	1	1			
26031	26031-0497	HARNESS,MAIN	1	1			
27002	27002-0007	RELAY-ASSY	1	1			
27002A	27002-1097	RELAY-ASSY,SIGNAL LAMP	1	1			
27003	27003-0053	HORN	1	1			
39156	39156-0291	PAD,ECU GUARD	2	2			
55020	55020-0388	GUARD,ECU,LWR	1	1			
55020A	55020-0389	GUARD,ECU,UPP	1	1			
56030	56030-0143	LABEL,FUSE BOX	1	1			
56030A	56030-0144	LABEL,FUSE BOX	1	1			
92037	92037-1163	CLAMP,SPEED,L=58	1	1			
92037A	92037-1903	CLAMP,SPEED,L=80.5	2	2			
92037B	92037-1993	CLAMP	2	2			
92072	92072-1195	BAND,L=202	3	3			
92153	92153-0410	BOLT,SOCKET,6X10	1	1			
92153A	92153-0906	BOLT,6X12	4	4			
120	120CB0510	BOLT-SOCKET,5X10	1	1			
130	130V0610	BOLT-FLANGED,6X10	1	1			

This catalog covers:

'07~'08 ZR750 L7F/L8F Chassis

GRID NO.

G-9

This grid covers:

Ignition Switch

F2770

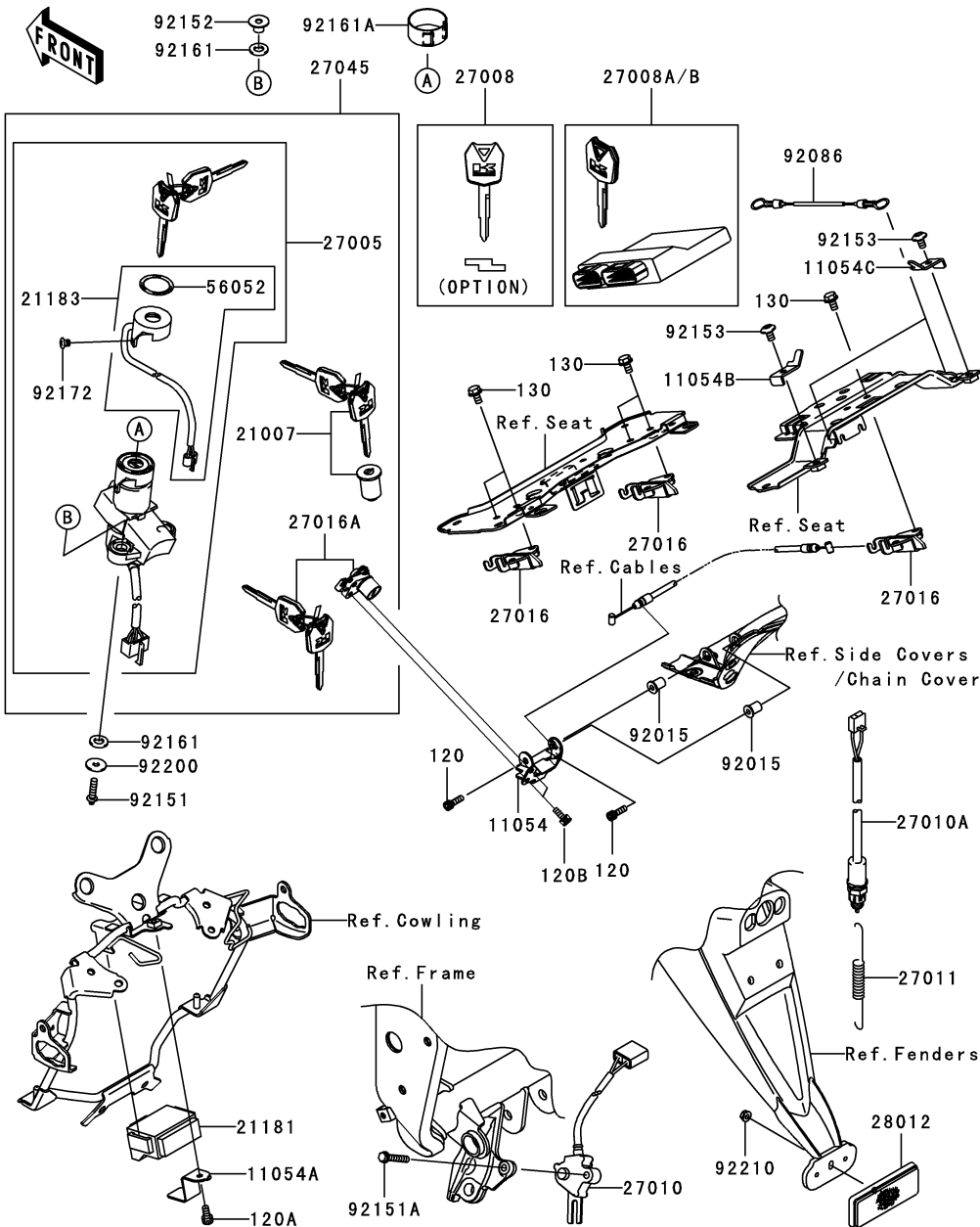

Ref. No.	Part No.	Description	Spec Code	Quantity-ZR750			
				'07	'08		
				L7F	L8F		
11054	11054-0510	BRACKET,SEAT LOCK	1	1			
11054A	11054-1182	BRACKET,IMMOBI AMP.	1	1			
11054B	11054-1721	BRACKET,SEAT LOCK,LH	1	1			
11054C	11054-1722	BRACKET,SEAT LOCK,RH	1	1			
21007	21007-5056	ROTOR,LOCK,TANK CAP	1	1			
21181	21181-0001	AMPLIFIER,IMMOBI	1	1			
21183	21183-0002	ANTENNA,IMMOBI	1	1			
27005	27005-5138	SWITCH-ASSY-IGNITION	1	1			
27008	27008-0029	KEY-LOCK,BLANK,IMMOBI,SUB	1	1			
	(OPTION)						
27008A	27008-5033	MASTER KEY SET(BLANK),IMMOBI	1				
27008B	27008-5038	MASTER KEY SET(BLANK),IMMOBI		1			
27010	27010-0065	SWITCH,SIDE STAND	1	1			
27010A	27010-1479	SWITCH,REAR BRAKE	1	1			
27011	27011-021	SPRING,BRAKE LAMP SWITCH	1	1			
27016	27016-1115	LOCK-ASSY,SEAT STRIKER	3	3			
27016A	27016-5310	LOCK-ASSY,SEAT	1	1			
27045	27045-5338	SWITCH-ASSY	1	1			
28012	28012-1077	REFLECTOR-REFLEX	1	1			
56052	56052-0292	MARK,IMMOBI	1	1			
92015	92015-1757	NUT,WELL,5MM	2	2			
92086	92086-1075	WIRE,L=150	2	2			
92151	92151-1946	BOLT,TORX,6X22	2	2			
92151A	92151-1982	BOLT,6X35	1	1			
92152	92152-0352	COLLAR	2	2			
92153	92153-0410	BOLT,SOCKET,6X10	2	2			
92161	92161-0240	DAMPER,IGNITION SWITCH	4	4			
92161A	92161-0257	DAMPER,IGNITION SWITCH	1	1			
92172	92172-0188	SCREW,4X8	2	2			
92200	92200-0212	WASHER,6X20X1.6	2	2			
92210	92210-0007	NUT,FLANGED,5MM	1	1			
120	120CA0516	BOLT-SOCKET,5X16	2	2			
120A	120CB0510	BOLT-SOCKET,5X10	1	1			
120B	120W0512	BOLT-SOCKET,5X12	2	2			
130	130L0612	BOLT-FLANGED,6X12	6	6			

This catalog covers:

'07~'08 ZR750 L7F/L8F Chassis

GRID NO.

G-10

This grid covers:

Owner's Tools

F2810

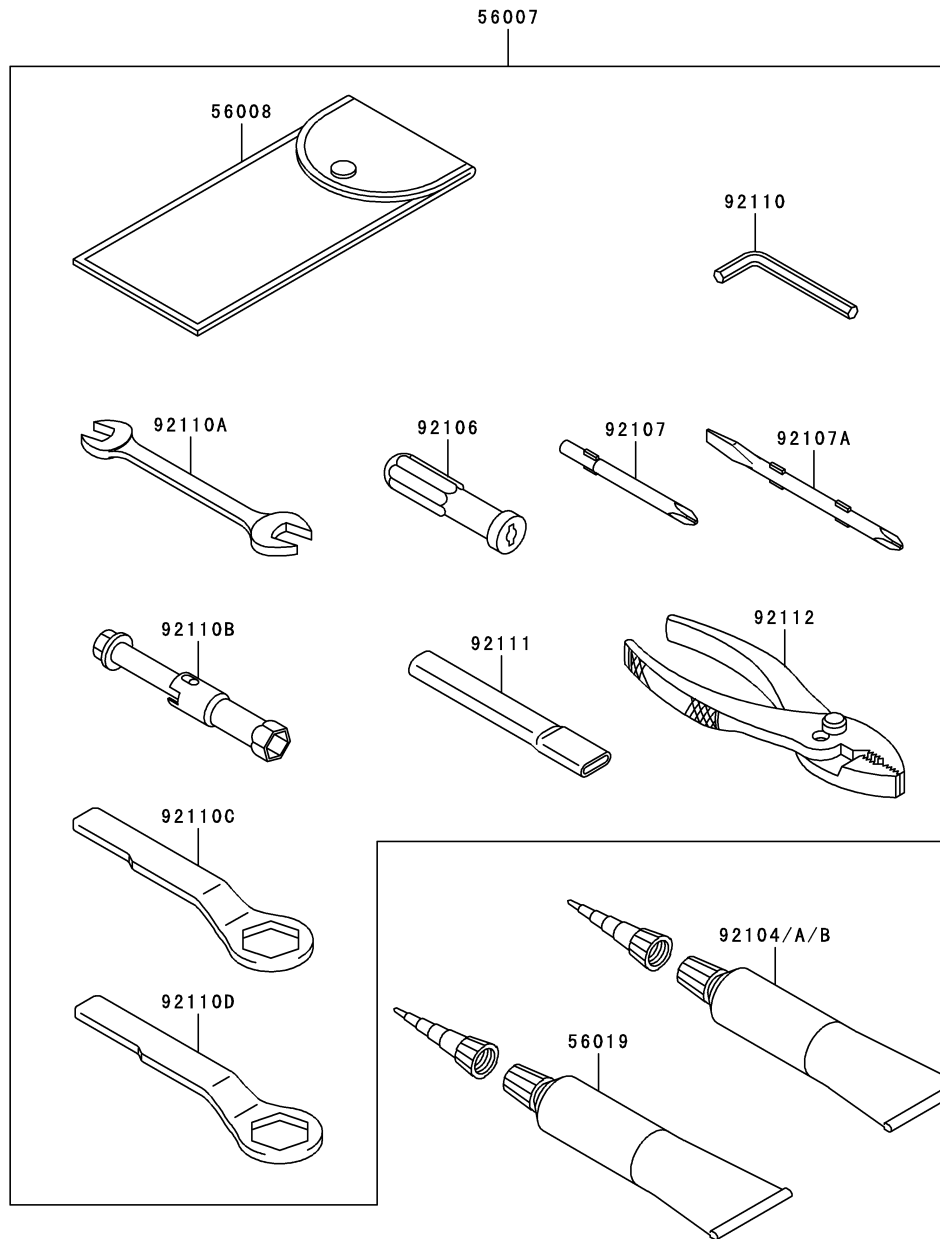

Ref. No.	Part No.	Description	Spec Code	Quantity-ZR750			
				'07	'08		
				L7F	L8F		
56007	56007-0042	TOOL-KIT	1	1			
56008	56008-1075	BAG,TOOL	1	1			
56019	56019-120	THREE BOND TB1211,HT/RS,WHITE	1	1			
92104	92104-0004	GASKET-LIQUID,TB1211F	1	1			
92104A	92104-1003	GASKET-LIQUID,BLACK,TB1105	1	1			
92104B	92104-1062	GASKET-LIQUID,BLACK TB1215B	1	1			
92106	92106-1001	GRIP-SCREW DRIVER	1	1			
92107	92107-005	TOOL-DRIVER,#3PHILLIPS	1	1			
92107A	92107-1051	TOOL-DRIVER,#2PHILLIPS&SLOT	1	1			
92110	92110-0001	TOOL-WRENCH,ALLEN,5MM	1	1			
92110A	92110-0019	TOOL-WRENCH,OPEN END,12X14	1	1			
92110B	92110-1132	TOOL-WRENCH,BOX,16MM	1	1			
92110C	92110-1147	TOOL-WRENCH,BOX END,27MM	1	1			
92110D	92110-1148	TOOL-WRENCH,BOX END,22MM	1	1			
92111	92111-1051	TOOL-BAR,BOX END WRENCH	1	1			
92112	92112-1001	TOOL-PLIERS	1	1			

This catalog covers:

'07~'08 ZR750 L7F/L8F Chassis

GRID NO.

G-11

This grid covers:

Labels

F2860

Ref. No.	Part No.	Description	Spec Code	Quantity-ZR750			
				'07	'08		
				L7F	L8F		

56031	56031-1441	LABEL-MANUAL,ENGLISH/FRENCH				
		L----- WV	1	1		
56033	56033-0186	LABEL-MANUAL,DAILY SAFETY				
56033A	56033-0187	LABEL-MANUAL,CHAIN			1	1
56053	56053-0213	LABEL-SPECIFICATION,TIRE&LOAD			1	1
56070	56070-1143	LABEL,UNLEADED PETROL ONLY			1	1

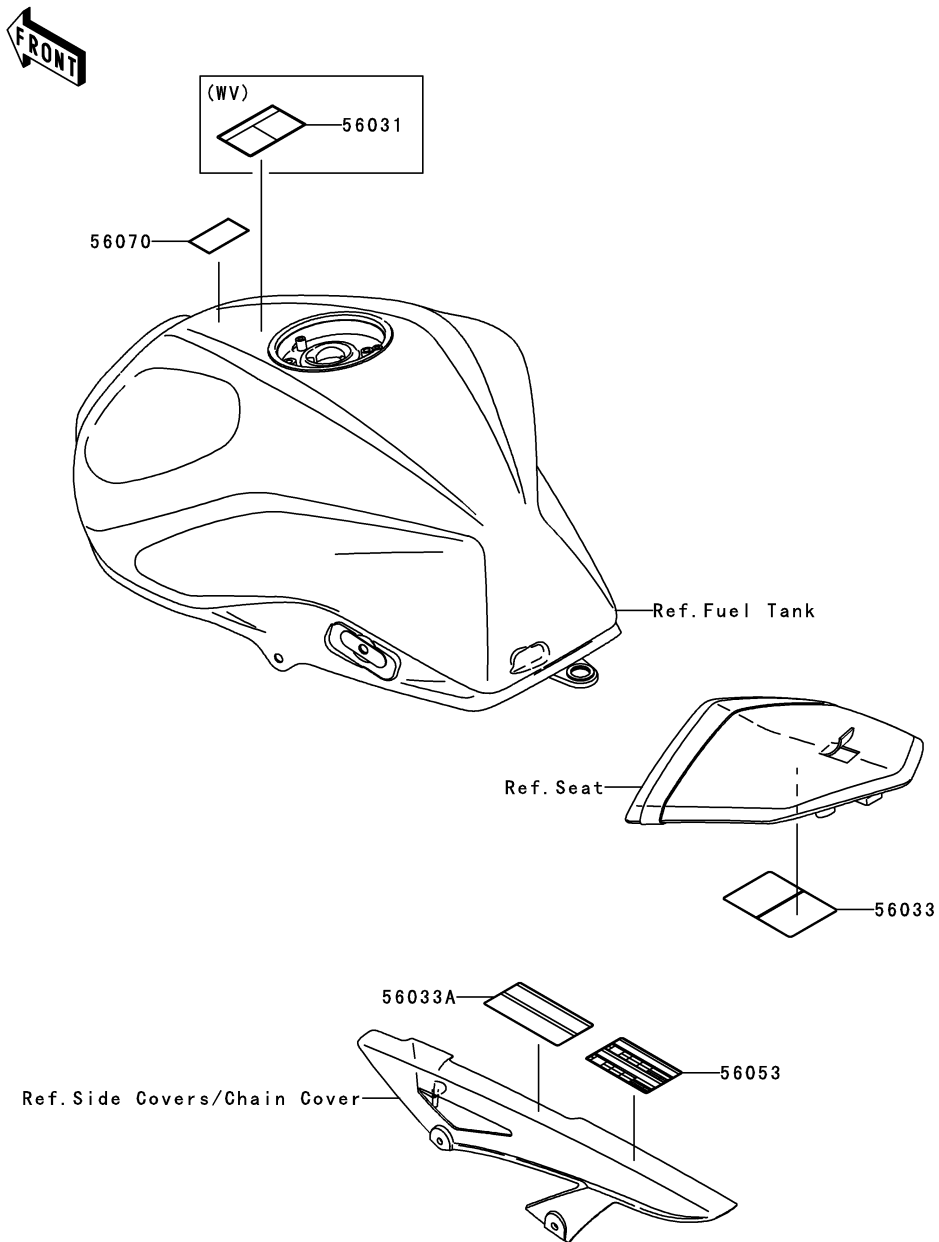

This catalog covers:

'07~'08 ZR750 L7F/L8F Chassis

GRID NO.

G-12

This grid covers:

Decals(Silver)(L7F)

F2861

Ref. No.	Part No.	Description	Spec Code	Quantity-ZR750			
				'07	'08		
56054	56054-0043	MARK,FUEL TANK,KAWASAKI					2
56054A	56054-0045	MARK,TAIL COVER,Z750					2

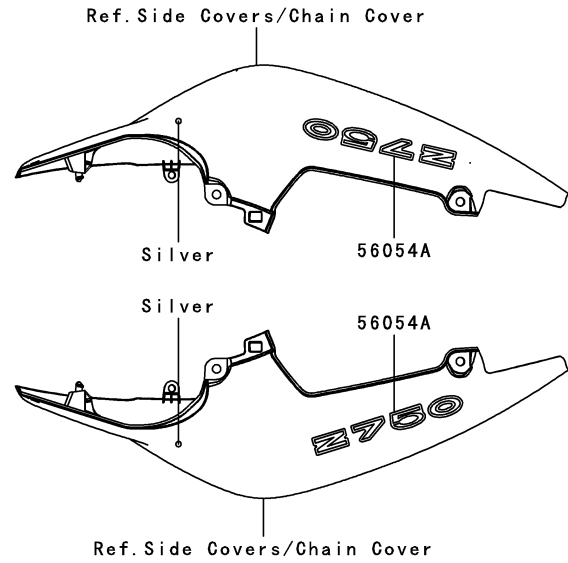
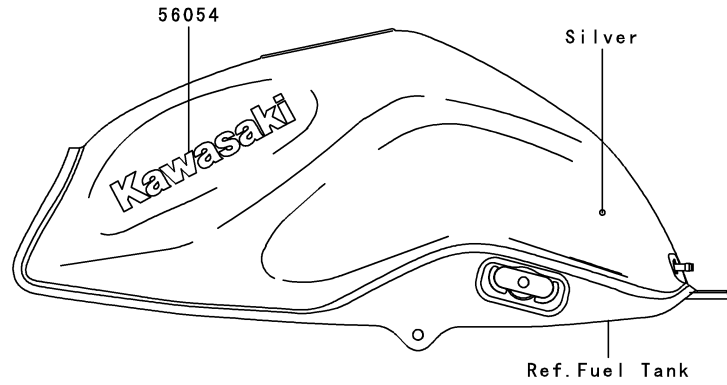

This catalog covers:

'07~'08 ZR750 L7F/L8F Chassis

GRID NO.

G-13

This grid covers:

Decals(Green)(L7F)

F2861A

Ref. No.	Part No.	Description	Spec Code	Quantity-ZR750			
				'07	'08		
56054	56054-0042	MARK,FUEL TANK,KAWASAKI					2
56054A	56054-0046	MARK,TAIL COVER,Z750					2

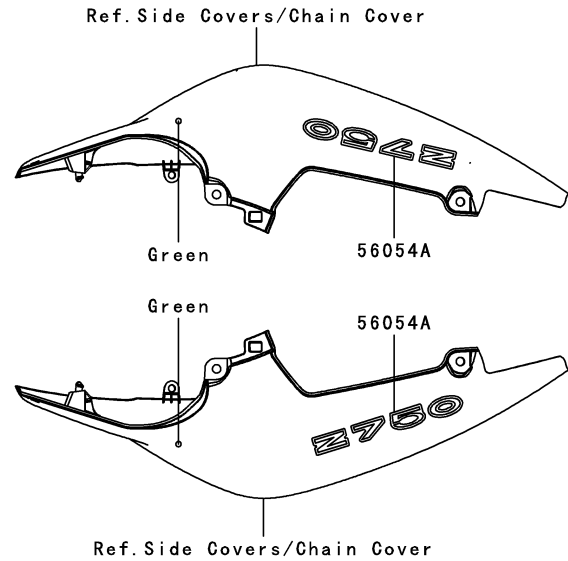
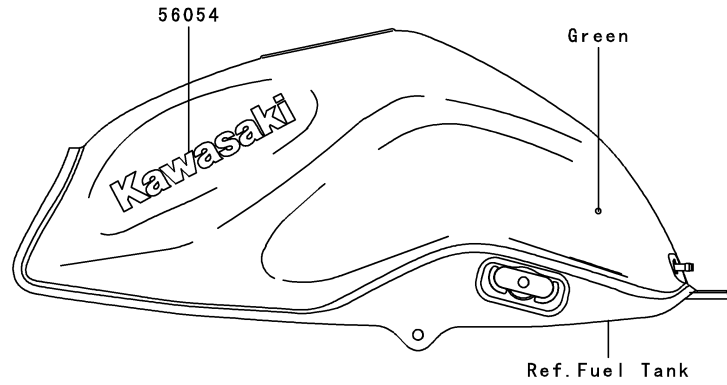

This catalog covers:

'07~'08 ZR750 L7F/L8F Chassis

GRID NO.

G-14

This grid covers:

Decals(Ebony)

F2861B

Ref. No.	Part No.	Description	Spec Code	Quantity-ZR750			
				'07	'08		
				L7F	L8F		
56054	56054-0042	MARK,FUEL TANK,KAWASAKI	2	2			
56054A	56054-0044	MARK,TAIL COVER,Z750	2	2			

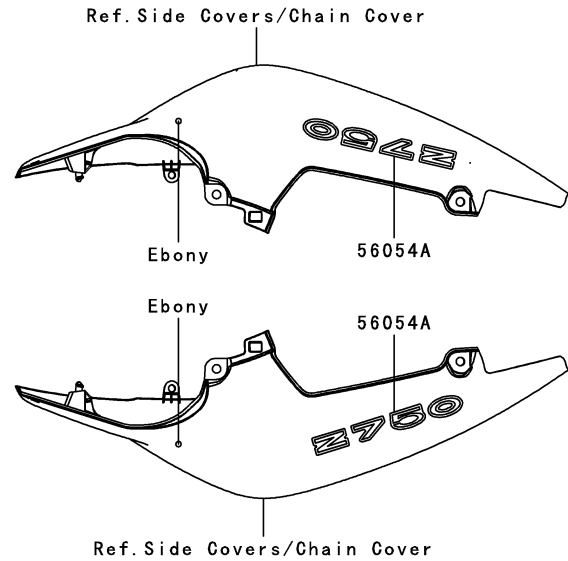
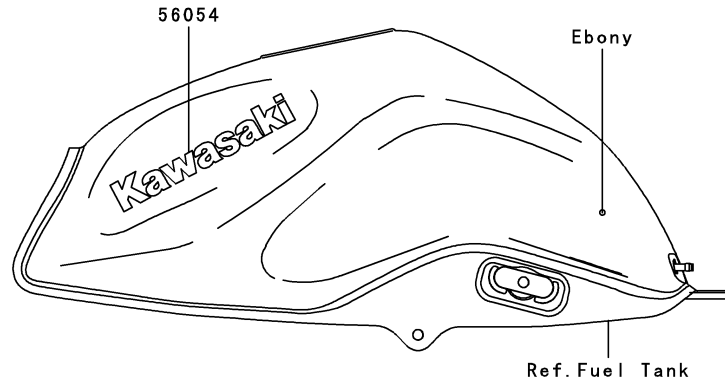

This catalog covers:

'07~'08 ZR750 L7F/L8F Chassis

GRID NO.

H-3

This grid covers:

Decals(Blue)(L8F)

F28610

Ref. No.	Part No.	Description	Spec Code	Quantity-ZR750			
				'07	'08		
				L7F	L8F		
56054	56054-0042	MARK,FUEL TANK,KAWASAKI		2			
56054A	56054-0046	MARK,TAIL COVER,Z750		2			

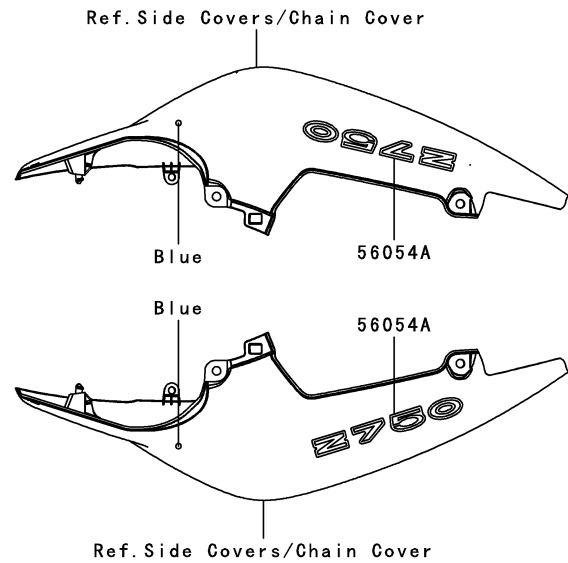
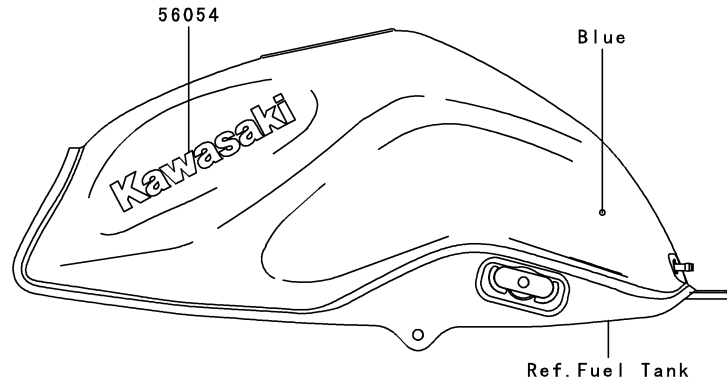

This catalog covers:

'07~'08 ZR750 L7F/L8F Chassis

GRID NO.

H-4

This grid covers:

Decals(Orange)(L8F)

F2861D

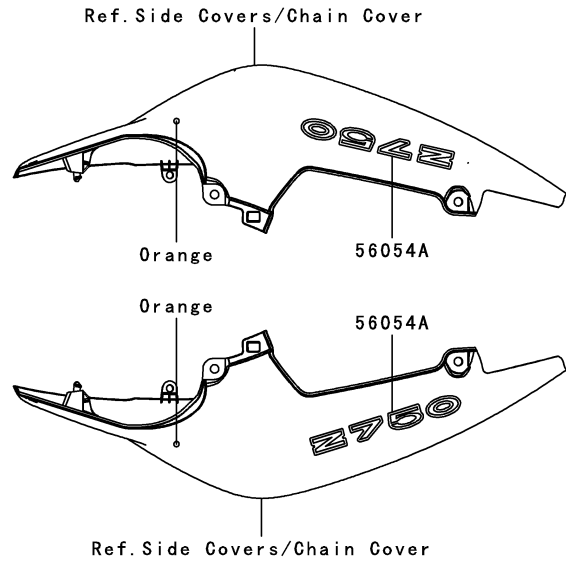
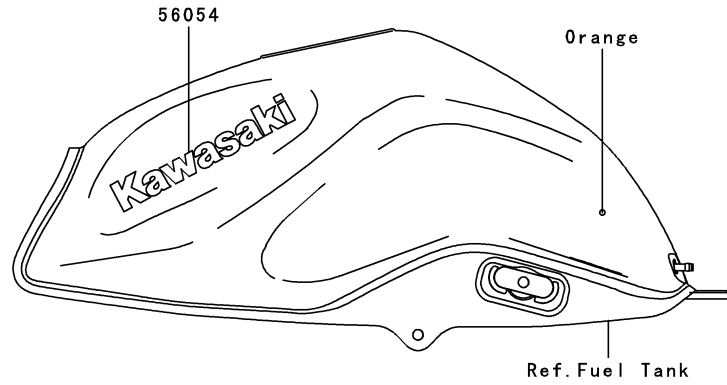

Ref. No.	Part No.	Description	Spec Code	Quantity-ZR750			
				'07	'08		
56054	56054-0043	MARK,FUEL TANK,KAWASAKI		2			
56054A	56054-0109	MARK,SEAT COVER,Z750		2			

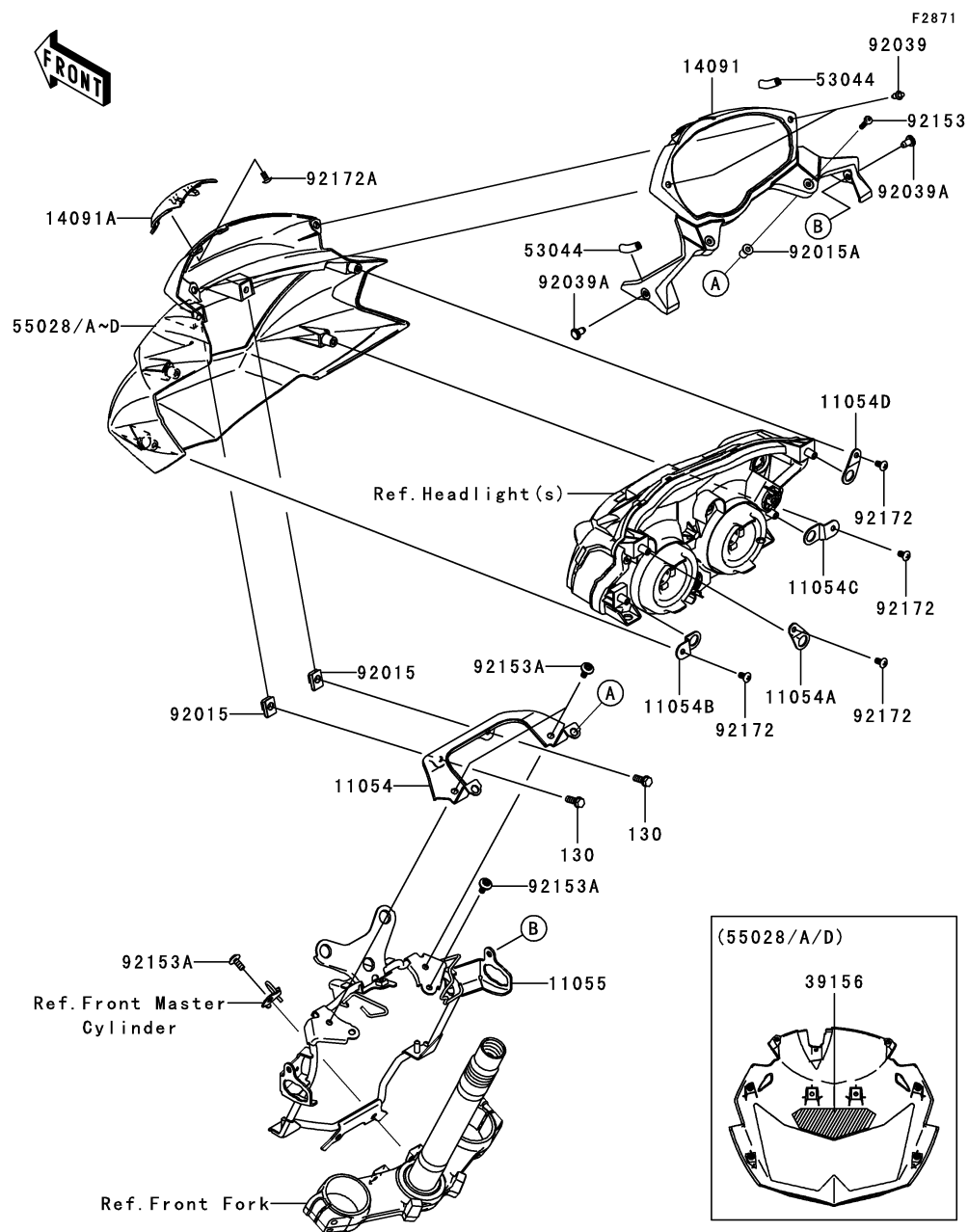

Ref. No.	Part No.	Description	Spec Code	Quantity-ZR750			
				'07	'08		
				L7F	L8F		
11054	11054-0936	BRACKET		1	1		
11054A	11054-0937	BRACKET,HEAD LAMP,UPP,LH		1	1		
11054B	11054-0938	BRACKET,HEAD LAMP,LWR,LH		1	1		
11054C	11054-0939	BRACKET,HEAD LAMP,LWR,RH		1	1		
11054D	11054-1185	BRACKET,HEAD LAMP,UPP,RH		1	1		
11055	11055-0076	BRACKET,METER		1	1		
14091	14091-0686	COVER,METER		1	1		
14091A	14091-0725	COVER,UPP COWLING		1	1		
39156	39156-0338	PAD,UPP COWLING		1	1		
53044	53044-0012	TRIM,L=40		2	2		
55028	55028-0147-H8	COWLING,UPP,EBONY		1	1		
55028A	55028-0147-17H	COWLING,UPP,P.ORANGE			1		
55028B	55028-0147-17M	COWLING,UPP,SILVER		1			
55028C	55028-0147-17P	COWLING,UPP,C.L.GREEN		1			
55028D	55028-0147-726	COWLING,UPP,M.O.BLUE			1		
92015	92015-1602	NUT,6MM		2	2		
92015A	92015-1757	NUT,WELL,5MM		2	2		
92039	92039-0023	RIVET		2	2		
92039A	92039-1286	RIVET		2	2		
92153	92153-0370	BOLT,SOCKET,5X18		2	2		
92153A	92153-1612	BOLT,SOCKET,6X14		6	6		
92172	92172-0006	SCREW,TAPPING,5X14		4	4		
92172A	92172-1061	SCREW,TAPPING,5X10		1	1		
130	130CA0618	BOLT-FLANGED,6X18		2	2		

This catalog covers:

'07~'08 ZR750 L7F/L8F Chassis

GRID NO.

H-6

This grid covers:

Cowling Lower

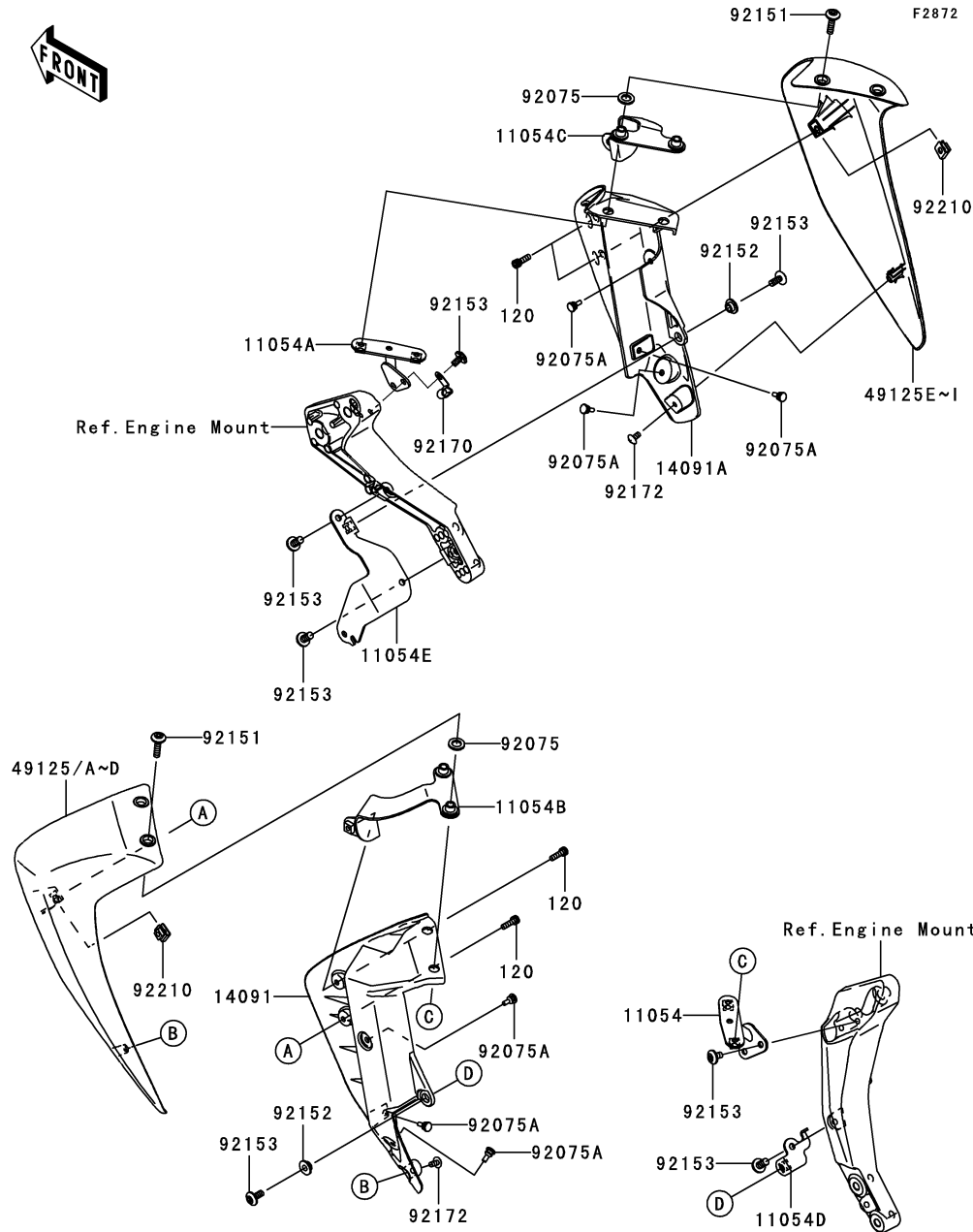

Ref. No.	Part No.	Description	Spec Code	Quantity-ZR750			
				'07	'08		
				L7F	L8F		
11054	11054-0940	BRACKET,SHROUD,UPP,LH		1	1		
11054A	11054-0941	BRACKET,SHROUD,UPP,RH		1	1		
11054B	11054-0942	BRACKET,SHROUD,LH		1	1		
11054C	11054-0943	BRACKET,SHROUD,RH		1	1		
11054D	11054-0944	BRACKET,SHROUD,LWR,LH		1	1		
11054E	11054-1861	BRACKET,SHROUD,LWR,RH		1	1		
14091	14091-0687	COVER,SHROUD,LH		1	1		
14091A	14091-0688	COVER,SHROUD,RH		1	1		
49125	49125-0028-H8	SHROUD,LH,EBONY		1	1		
49125A	49125-0028-17H	SHROUD,LH,P.ORANGE				1	
49125B	49125-0028-17M	SHROUD,LH,SILVER		1			
49125C	49125-0028-17P	SHROUD,LH,C.L.GREEN		1			
49125D	49125-0028-726	SHROUD,LH,M.O.BLUE				1	
49125E	49125-0029-H8	SHROUD,RH,EBONY		1	1		
49125F	49125-0029-17H	SHROUD,RH,P.ORANGE				1	
49125G	49125-0029-17M	SHROUD,RH,SILVER		1			
49125H	49125-0029-17P	SHROUD,RH,C.L.GREEN		1			
49125I	49125-0029-726	SHROUD,RH,M.O.BLUE				1	
92075	92075-1564	DAMPER		4	4		
92075A	92075-1808	DAMPER		6	6		
92151	92151-1611	BOLT,SOCKET,6X25		4	4		
92152	92152-0445	COLLAR		2	2		
92153	92153-1612	BOLT,SOCKET,6X14		9	9		
92170	92170-1804	CLAMP		1	1		
92172	92172-0175	SCREW,TAPPING,5X16		2	2		
92210	92210-1266	NUT,5MM		2	2		
120	120CB0516	BOLT-SOCKET,5X16		4	4		

This catalog covers:

'07~'08 ZR750 L7F/L8F Chassis

GRID NO.

H-7

This grid covers:

Manual

F2920

Owner's Manual
(Local Procurement)

99976/A~C
99986/A

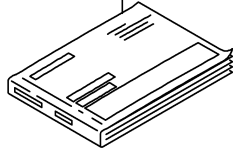

Ref. No.	Language
(99976/B)	English
	French
	German
(99976A/C)	Italian
	Spanish
(99986/A)	Dutch
(99986/A)	English

Service Manual

99901
99924
99953
99954
99955
99956

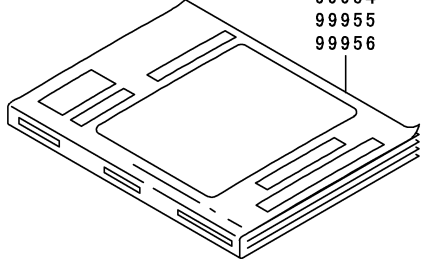

Ref. No.	Language
(99901)	Dutch
(99924)	English
(99953)	German
(99954)	French
(99955)	Italian
(99956)	Spanish

A&P Manual

99903
99939
99946
99950
99951
99952

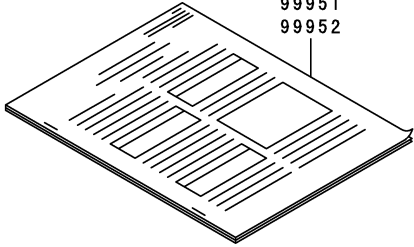

Ref. No.	Language
(99903)	Dutch
(99939)	English
(99946)	German
(99950)	French
(99951)	Italian
(99952)	Spanish

Ref. No.	Part No.	Description	Spec Code	Quantity-ZR750			
				'07	'08		
				L7F	L8F		
99901	99901-0004-01	SERVICE MANUAL,DUTCH	1	1			
99903	99903-0004-01	A&P MANUAL,DUTCH	1	1			
99924	99924-1381-01	SERVICE MANUAL,ENGLISH	1	1			
99939	99939-1321-01	A&P MANUAL,ENGLISH	1	1			
99946	99946-1041-01	A&P MANUAL,GERMAN	1	1			
99950	99950-1046-01	A&P MANUAL,FRENCH	1	1			
99951	99951-1032-01	A&P MANUAL,ITALIAN	1	1			
99952	99952-1016-01	A&P MANUAL,SPANISH	1	1			
99953	99953-1038-01	SERVICE MANUAL,GERMAN	1	1			
99954	99954-1047-01	SERVICE MANUAL,FRENCH	1	1			
99955	99955-1030-01	SERVICE MANUAL,ITALIAN	1	1			
99956	99956-1014-01	SERVICE MANUAL,SPANISH	1	1			
99976	99976-1306	OWNER'S MANUAL,EN/FR/DE	1				
99976A	99976-1362	OWNER'S MANUAL,IT/ES/NL	1				
99976B	99976-1409	OWNER'S MANUAL,EN/FR/DE		1			
99976C	99976-1410	OWNER'S MANUAL,IT/ES/NL		1			
99986	99986-1357	OWNER'S MANUAL,ENGLISH	1				
99986A	99986-1436	OWNER'S MANUAL,ENGLISH		1			

This catalog covers:

'07~'08 ZR750 L7F/L8F

GRID NO.

This grid covers:

L-13

Numerical Parts Index

Part No.	Grid No.	Part No.	Grid No.	Part No.	Grid No.	Part No.	Grid No.	Part No.	Grid No.	Part No.	Grid No.
11004-0074	B-3	11061-1168	B-5	130G0512	C-12	13271-1997	C-5	16142-0054	C-10	23035-1066	G-6
11005-0083	B-5	11065-0018	C-7	130G0630	F-11	13280-0017	F-9	16142-1146	C-10	23037-0061	G-7
11005-0098	B-5	11065-0055	E-7	130J0612	D-3	13280-0022	C-10	16146-0075-17H	F-12	23037-0062	G-7
11008-0093	B-3	11065-0188-499	F-10	130J0616	C-6	132G0618	B-4	16146-0075-17M	F-12	23037-0068	G-7
11008-0145	B-3	11065-0189-499	F-10	130J0816	E-4	14001-0117	C-3	16146-0075-17P	F-12	23037-0069	G-7
11009-1127	F-10	11065-1247	B-4	130L0518	B-7	14001-0131	C-3	16146-0075-726	F-12	236C0410	F-9
11009-1145	D-3	112J0630	F-9	130L0612	E-7	14013-1051	C-3	16146-0075-H8	F-12	25009-004	G-6
11009-1856	B-7	12004-0005	B-8	130L0612	G-9	14014-0027	C-3	16154-0057	C-10	25023-0027	F-14
11010-0126	B-6	12005-0010	B-8	130L0620	C-11	14025-1725	G-6	16160-0039	D-3	25031-0145	F-14
11012-1084	D-3	12009-0001	B-8	130P0645	B-3	14026-0053	C-5	16160-0136	C-10	26006-0001	G-8
11013-1302	B-6	12011-1052	B-8	130V0610	G-8	14026-0060	C-5	16160-0152	C-10	26006-1078	G-8
11051-1503	G-6	12021-1130	B-4	130Y0610	B-5	14031-0060	C-5	16163-0081	C-7	26011-0107	G-8
11053-1070	D-3	12032-0008	B-8	13102-0007	B-11	14031-0092	C-5	16170-0005	C-7	26011-0108	G-8
11054-0510	G-9	12048-0035	B-9	13107-0046	C-10	14032-0106	C-5	18091-0474	B-7	26011-0121	C-13
11054-0646	C-14	12053-1399	B-9	13107-0157	B-9	14032-0113	C-5	18091-0483	B-7	26011-0159	G-8
11054-0751	E-6	12053-1473	B-9	13107-1376	B-9	14073-0113	B-6	21003-0046	C-11	26012-0088	G-8
11054-0875	C-11	12053-1478	B-9	13107-1377	C-13	14073-0157	B-6	21007-0021	C-11	26031-0313	C-7
11054-0936	H-5	120CA0516	G-9	13127-0008	B-12	14073-0164	B-6	21007-0081	C-12	26031-0497	G-8
11054-0937	H-5	120CA0608	B-6	13128-0005	B-12	14075-0001	D-3	21007-5056	G-9	26031-0541	C-12
11054-0938	H-5	120CA0616	F-7	13140-1266	B-13	14079-0009	C-13	21040-0001	C-13	27002-0007	G-8
11054-0939	H-5	120CB0510	G-8	13140-1267	B-13	14091-0657	C-5	21066-1127	C-11	27002-1097	G-8
11054-0940	H-6	120CB0510	G-9	13144-0007	B-12	14091-0686	H-5	21163-0024	C-13	27003-0053	G-8
11054-0941	H-6	120CB0516	H-6	13145-0032	B-13	14091-0687	H-6	21169-1058	C-13	27005-5138	G-9
11054-0942	H-6	120CB0610	B-7	13151-1085	B-13	14091-0688	H-6	21171-1286	C-12	27008-0029	G-9
11054-0943	H-6	120P0525	C-9	13159-1061	F-5	14091-0689-18T	E-5	21174-0003	B-7	27008-5033	G-9
11054-0944	H-6	120S0510	C-13	13159-1065	F-7	14091-0689-7C	E-5	21175-0098	C-9	27008-5038	G-9
11054-1182	G-9	120S0620	F-9	13161-0057	B-14	14091-0690-18T	E-5	21175-0173	C-9	27010-0025	F-5
11054-1185	H-5	120S0830	F-9	13187-0003	B-11	14091-0690-7C	E-5	21176-0026	C-9	27010-0065	G-9
11054-1721	G-9	120W0512	G-9	13194-1096	C-13	14091-0704	B-4	21176-0054	C-3	27010-1094	F-9
11054-1722	G-9	120W0625	B-7	13216-0020	C-10	14091-0711	F-14	21176-0058	C-9	27010-1313	C-3
11054-1861	H-6	13001-0018	B-5	13236-0106	B-14	14091-0712	B-7	21176-0064	C-9	27010-1376	C-13
11054-1887	F-7	13002-0022	B-5	13236-0140	F-5	14091-0725	H-5	21176-0085	C-9	27010-1479	G-9
11054-1892	C-9	13008-0004	B-5	13236-0142	B-14	14091-0815-18T	E-5	21176-1120	C-9	27011-021	G-9
11054-1909	F-5	13031-0088	B-10	13236-0143	F-3	14091-0815-7C	E-5	21176-2106	C-9	27016-1115	G-9
11054-1921	E-10	13042-0022	E-9	13239-0026	B-13	14091-0816-18T	E-5	21181-0001	G-9	27016-5310	G-9
11054-1922	E-10	13042-1005	F-9	13242-1395	B-14	14091-0816-7C	E-5	21183-0002	G-9	27045-5338	G-9
11054-1974	B-7	13070-0076	F-8	13251-1145-II	B-10	14091-0936	B-4	220C0525	F-9	28011-0076	F-14
11054-1992	G-8	13070-0077	F-6	13262-0064	B-12	14091-0937	C-5	220C0540	F-9	28012-1077	G-9
11055-0076	H-5	13087-0006	B-11	13262-0065	B-12	16007-1227	B-8	220D0514	D-3	31009-0004	E-6
11055-0341	B-7	13088-1124	B-11	13262-0069	B-12	16014-0002	C-7	223D0410	C-7	31064-0101	C-7
11060-1330	B-7	13089-013	B-11	13262-0070	B-12	16021-0017	C-7	224C0408	G-7	311AA0600	E-5
11060-1676	B-13	13089-1073	B-11	13262-0160	B-12	16065-0032	B-3	225F0412	F-7	32046-0114	F-12
11060-1952	F-11	13089-1126	B-11	13262-0162	B-12	16073-3707	C-7	23007-0039	G-7	32046-0117	F-12
11061-0029	F-6	13091-1041	B-11	13262-0163	B-12	16085-1303	C-13	23007-0040	G-7	32046-0118	F-12
11061-0104	B-4	13091-1624	F-9	13262-0164	B-12	16097-0004	C-10	23007-0079	G-5	32046-0120	F-12
11061-0107	C-10	13091-1992	C-13	13262-0550	B-12	16115-1009	C-5	23008-0063	G-5	32052-0068	E-5
11061-0227	B-4	13095-0070	B-11	13262-0551	B-12	16126-1140	E-12	23016-1200	G-6	32065-0002	E-10
11061-0294	C-5	130BA0514	F-13	13271-0056	C-7	16126-1437	B-6	23017-0003	G-5	32065-0003	E-10
11061-1166	C-5	130CA0618	H-5	13271-0747	C-3	16130-1058	C-10	23025-0027	G-6	32085-0047	E-9
11061-1167	C-6	130G0508	C-7	13271-0748	C-3	16142-0037	C-10	23026-1064	G-6	32152-1545	C-3

This catalog covers:

'07~'08 ZR750 L7F/L8F

GRID NO.

This grid covers:

L-14 Numerical Parts Index

Part No.	Grid No.	Part No.	Grid No.	Part No.	Grid No.	Part No.	Grid No.	Part No.	Grid No.	Part No.	Grid No.
32160-0263-11E	E-3	36040-0044-18T	G-4	41073-0053-795	E-13	43082-0073	F-8	49033-0013	C-7	54010-0083	B-7
32160-0263-18R	E-3	36040-0044-H8	G-4	41073-0053-R2	E-13	43082-0079	F-6	49034-0025	C-6	54010-0084	B-7
32190-0009	E-4	36040-0071-17H	G-4	41073-0115-795	E-14	43095-0342	F-7	49034-0029	C-6	54011-1424	G-3
32190-0248-18R	E-4	36040-0071-17M	G-4	41073-0115-R2	E-14	43095-0363	F-5	49040-0018	C-8	54012-0068	G-3
32190-0248-7C	E-4	36040-0071-17P	G-4	41075-0007	E-12	43095-0366	F-5	49047-0010	B-13	54012-0118	G-3
32190-0249-18R	E-4	36040-0071-726	G-4	41075-0008	E-12	43095-0370	F-5	49054-1067	D-3	55020-0061	E-7
32190-0249-7C	E-4	36040-0071-H8	G-4	41075-0009	E-12	43095-0371	F-7	49056-0001	C-7	55020-0237	E-5
32190-0250-18R	E-4	36040-0072-17H	G-4	41080-0089	F-8	44008-0030-499	F-10	49063-1055	C-10	55020-0238	E-5
32190-0250-7C	E-4	36040-0072-17M	G-4	41080-0103-11I	F-6	44008-0030-KX	F-10	49065-1078	C-10	55020-0388	G-8
32190-0251-18R	E-4	36040-0072-17P	G-4	411S0600	B-7	44013-0084-18R	F-10	49078-0023	B-8	55020-0389	G-8
32190-0251-7C	E-4	36040-0072-726	G-4	42033-0003	E-14	44013-0084-21	F-10	49085-1066	D-3	55020-0398	G-4
33001-0103-11E	E-7	36040-0072-H8	G-4	42036-0050	F-8	44013-0085-18R	F-10	49091-0001	F-5	55028-0147-17H	H-5
33001-0103-18R	E-7	36040-0079-6Z	G-4	42036-1251	E-14	44013-0085-21	F-10	49091-0001	F-7	55028-0147-17M	H-5
33032-0005	E-7	39007-0006	E-8	42036-1258	E-8	44023-0053	F-10	49106-0069	B-7	55028-0147-17P	H-5
33040-0009	E-7	39060-0034	C-14	42036-1264	E-7	44023-0054	F-10	49118-0089	B-9	55028-0147-726	H-5
33040-0012	E-7	39062-0190	D-3	42036-1342	E-8	44026-0102	F-10	49118-0090	B-9	55028-0147-H8	H-5
33040-1143	E-7	39062-0207	D-3	42036-1360	E-8	44037-0066-11E	F-10	49125-0028-17H	H-6	550AA2015	F-7
34003-0025	E-9	39062-0208	D-3	42041-0017	E-14	44037-0066-18R	F-10	49125-0028-17M	H-6	550D4035	E-14
34003-1474	E-9	39062-0213	D-3	42045-018	E-14	44039-0057-11E	F-10	49125-0028-17P	H-6	551A0408	C-10
34024-0056-11E	E-11	39062-0234	D-3	43010-1062	F-7	44039-0057-18R	F-10	49125-0028-726	H-6	551A0814	C-5
34024-0058-18R	E-11	39062-1226	D-3	43015-0083	F-7	44071-5044	F-10	49125-0028-H8	H-6	56001-0053	F-9
34028-0004	E-9	39062-1916	D-3	43015-0105	F-5	44071-5045	F-10	49125-0029-17H	H-6	56001-0054	F-9
34028-0005	E-9	39110-0021	B-14	43020-0008	F-5	44071-5061	F-10	49125-0029-17M	H-6	56001-0117	F-9
34028-1428	E-9	39111-0050	E-8	43020-1057	F-7	44071-5062	F-10	49125-0029-17P	H-6	56001-0118	F-9
34028-1429	E-9	39156-0284	E-10	43022-1010	F-5	45014-0195-23A	F-4	49125-0029-726	H-6	56007-0042	G-10
34028-1430	E-9	39156-0285	E-10	43026-0009	F-7	46003-0139-4P	F-9	49125-0029-H8	H-6	56008-1075	G-10
35004-0024-17H	E-10	39156-0286	G-4	43026-1051	F-5	46012-1338	F-9	51044-0042	C-8	56019-120	G-10
35004-0024-17M	E-10	39156-0288	E-6	43027-1051	F-5	46012-1339	F-9	51049-0012	F-11	56030-0143	G-8
35004-0024-17P	E-10	39156-0291	G-8	43027-1053	F-7	46012-1340	F-9	51085-5249-17P	F-11	56030-0144	G-8
35004-0024-726	E-10	39156-0292	E-3	43028-1057	F-5	46019-0001	F-9	51085-5249-726	F-11	56031-1441	G-11
35004-0024-H8	E-10	39156-0317	E-6	43028-1065	F-7	46075-1144	F-9	51085-5249-H8	F-11	56033-0186	G-11
35019-0047	E-10	39156-0318	E-3	43034-1163	F-5	46076-0005	F-9	51085-5251-17H	F-11	56033-0187	G-11
35063-0299-18R	E-5	39156-0320	F-12	43044-0014	F-8	46091-0118	F-9	51085-5251-17M	F-11	56052-0292	G-9
35063-0299-458	E-5	39156-0338	H-5	43044-0024	F-6	46091-1891	F-9	52005-0025	F-11	56053-0213	G-11
35063-0300-18R	E-5	39156-0343	E-3	43044-0025	F-6	46092-0003	F-9	52005-1120	C-5	56054-0042	G-13
35063-0300-458	E-5	39156-0344	F-14	43048-0008	F-8	46102-0102	B-11	53003-0095-MA	F-12	56054-0042	G-14
35063-0301-11E	E-5	39156-0345	E-5	43048-1068	F-6	461K0500	C-13	53003-0096-MA	F-12	56054-0042	H-3
35063-0301-18R	E-5	39156-0415	F-12	43049-1060	F-6	480J1100	C-10	53044-0012	B-7	56054-0043	G-12
35063-0302-11E	E-5	39156-0416	F-12	43049-1061	F-6	482J0200	B-14	53044-0012	E-6	56054-0043	H-4
35063-0302-18R	E-5	39156-0417	F-12	43056-1055	F-6	482L0100	E-9	53044-0012	H-5	56054-0044	G-14
35063-0321	C-14	39156-0419	F-12	43056-1055	F-8	482L5000	E-9	53044-0018	E-3	56054-0045	G-12
36001-0108-6Z	G-4	39178-0097	B-7	43057-1001	F-6	49002-1116	B-3	53065-0015-17H	F-12	56054-0046	G-13
36001-0109-6Z	G-4	39192-0049	D-3	43057-1001	F-8	49006-0058	F-8	53065-0015-17M	F-12	56054-0046	H-3
36001-0135-6Z	G-4	39192-0071	D-3	43064-007	F-7	49006-1088	F-6	53065-0015-17P	F-12	56054-0109	H-4
36001-0136-6Z	G-4	39192-1151	D-3	43078-0033	D-3	49006-1242	F-6	53065-0015-726	F-12	56070-1143	G-11
36014-0025	G-4	39193-0014	C-3	43078-0040	F-7	49006-1242	F-8	53065-0015-H8	F-12	59026-0014	C-12
36040-0043-11J	G-4	41009-0173	E-12	43078-1099	F-5	49016-0032	C-14	53066-0138-MA	F-12	59051-0037	C-13
36040-0043-18T	G-4	41009-0174	E-12	43080-0050-DJ	F-8	49016-0038	G-5	53066-0139-12Y	F-12	59071-0014	C-7
36040-0043-H8	G-4	41068-0023	E-14	43080-0054-DJ	F-6	49016-1044	F-5	54010-0047	G-3	59071-3752	C-7
36040-0044-11J	G-4	41068-0038	E-13	43080-0055-DJ	F-6	49016-1147	F-5	54010-0048	G-3	59091-0007	B-7

This catalog covers:

'07~'08 ZR750 L7F/L8F

GRID NO.

This grid covers:

L-15

Numerical Parts Index

Part No.	Grid No.	Part No.	Grid No.	Part No.	Grid No.	Part No.	Grid No.	Part No.	Grid No.	Part No.	Grid No.
59256-1074	C-10	92015-1603	E-10	92033-1249	B-12	92049-1056	E-14	92066-1216	F-9	92112-1001	G-10
59502-0025	C-14	92015-1623	C-13	92037-010	F-11	92049-1057	E-13	92066-3780	B-9	92139-0067	B-11
600A0500	B-12	92015-1700	E-5	92037-1163	G-8	92049-1181	E-7	92069-0003	G-7	92139-1090	B-12
600A0800	E-9	92015-1700	G-4	92037-1460	B-6	92049-1223	E-8	92069-1016	G-5	92139-1108	B-10
601B6004UU	E-13	92015-1724	E-7	92037-147	B-6	92049-1225	E-8	92069-1055	G-6	92139-1109	B-10
601B6204UU	E-14	92015-1757	F-12	92037-147	D-3	92049-1287	E-14	92069-1126	G-5	92139-1110	B-10
601B6205UU	E-14	92015-1757	G-4	92037-1827	F-12	92049-1308	B-8	92070-1264	C-12	92143-1595	B-14
610A0406	B-13	92015-1757	G-9	92037-1827	F-5	92049-1336	C-10	92070-1265	C-12	92143-1962	D-3
670D1505	C-3	92015-1757	H-5	92037-1903	G-8	92049-1380	E-7	92071-1120	C-13	92144-1451	C-7
670D1509	B-9	92015-1795	F-10	92037-1993	G-8	92049-1449	F-8	92071-1187	C-11	92144-1523	B-14
670D2014	B-9	92015-1962	F-9	92038-1060	C-11	92049-1450	F-8	92071-2140	B-6	92144-1898	B-11
670E5075	C-8	92015-1963	B-12	92039-0014	C-14	92049-1474	C-3	92072-0012	C-7	92145-0066	B-11
671B2560	E-14	92022-077	C-10	92039-0023	H-5	92049-1475	C-5	92072-0090	E-6	92145-0360	E-9
671B2565	C-10	92022-1028	E-4	92039-0027	C-14	92049-1483	E-3	92072-1195	G-8	92145-0435	F-3
702A06750	F-11	92022-1088	F-9	92039-1256	G-4	92049-1492	B-14	92075-015	F-11	92145-0493	F-8
92001-1998	C-7	92022-1109	B-12	92039-1286	E-10	92049-1493	E-8	92075-101	F-11	92145-0515	E-11
92002-1086	C-14	92022-112	B-12	92039-1286	H-5	92049-1520	C-3	92075-1011	E-5	92145-0524	F-6
92002-1143	B-3	92022-1405	F-14	92041-1060	F-9	92055-0114	D-3	92075-1011	G-4	92145-1122	B-14
92002-1154	C-10	92022-1405	G-5	92042-007	C-5	92055-049	C-5	92075-1123	C-11	92145-1159	B-11
92002-1183	E-8	92022-1582	E-7	92042-030	C-10	92055-086	B-9	92075-1123	C-14	92145-1286	F-9
92002-1322	F-5	92022-1601	F-7	92043-0104	F-7	92055-112	D-3	92075-1446	F-12	92145-1319	E-9
92002-1323	F-5	92022-1628	B-14	92043-0137	F-8	92055-1251	F-5	92075-1564	H-6	92150-1019	C-3
92002-1337	E-4	92022-1868	B-11	92043-1037	C-3	92055-1251	F-7	92075-161	F-13	92150-1019	E-9
92002-1449	C-3	92022-2200	C-13	92043-1262	C-10	92055-1260	C-13	92075-1634	D-3	92150-1114	E-9
92002-1449	C-5	92022-289	B-7	92043-1263	B-3	92055-1261	C-13	92075-1736	F-11	92150-1186	C-14
92002-1696	B-13	92022-304	B-5	92043-1263	C-10	92055-1262	C-13	92075-1808	G-4	92150-1216	B-10
92002-1756	B-3	92022-3742	F-5	92043-1263	C-5	92055-1333	F-10	92075-1808	H-6	92150-1237	C-13
92002-1778	C-3	92026-0045	F-10	92043-1520	F-6	92055-1343	C-3	92075-1912	C-9	92150-1251	C-4
92002-1796	C-5	92026-022	B-11	92043-1520	F-8	92055-1350	D-3	92075-1927	F-13	92150-1268	E-9
92004-0025	B-3	92026-1497	B-11	92043-1595	E-9	92055-1352	B-4	92081-1620	C-7	92150-1328	F-5
92004-0028	E-14	92027-1780	F-11	92043-1641	E-9	92055-1401	B-3	92081-1708	B-14	92150-1368	B-3
92005-1238	C-3	92027-1920	C-11	92043-1690	C-3	92055-1503	C-10	92081-1737	F-7	92150-1398	F-10
92009-1158	G-7	92028-1735	B-12	92043-4009	B-3	92055-1570	C-5	92086-1075	G-9	92150-1483	C-4
92009-1164	F-14	92028-1739	B-12	92043-4009	B-4	92055-1571	C-10	92092-1058	F-4	92150-1548	C-4
92009-1197	F-14	92028-1827	B-10	92045-0003	B-12	92055-1622	C-7	92092-1087	B-7	92150-1622	C-4
92009-1257	F-9	92028-1828	B-10	92045-0017	E-7	92055-1639	C-9	92093-0002	B-6	92150-1633	D-3
92009-1378	G-6	92028-1829	B-10	92045-1045	B-13	92055-3018	C-10	92093-0063	B-6	92150-1692	F-6
92009-1502	C-7	92028-1866	B-10	92045-1235	B-11	92057-0129	E-14	92093-1472	F-10	92150-1692	F-8
92009-1570	F-5	92028-1867	B-10	92045-1384	E-3	92057-1453	B-9	92104-0004	G-10	92150-1755	B-3
92009-1621	B-6	92028-1868	B-10	92046-0008	E-7	92058-0007	E-14	92104-1003	G-10	92150-1771	F-6
92009-1661	F-7	92028-1915	B-12	92046-037	C-3	92062-1092	C-3	92104-1062	G-10	92150-1771	F-8
92015-1180	E-4	92028-1968	B-12	92046-1010	C-5	92065-097	C-6	92106-1001	G-10	92150-1779	C-11
92015-1188	E-11	92033-015	B-12	92046-1219	B-12	92065-097	C-9	92107-005	G-10	92150-1792	B-7
92015-1189	E-4	92033-026	B-12	92046-1263	B-11	92066-0002	B-3	92107-1051	G-10	92150-1794	C-4
92015-1233	F-5	92033-1036	F-10	92046-1272	E-8	92066-0003	C-3	92110-0001	G-10	92150-1836	F-5
92015-1311	B-10	92033-1041	E-7	92046-1273	E-8	92066-0032	F-10	92110-0019	G-10	92150-1841	D-3
92015-1367	B-7	92033-1043	E-14	92046-1303	B-12	92066-0071	E-3	92110-1132	G-10	92151-1133	C-10
92015-1487	C-14	92033-1099	B-5	92048-1114	C-13	92066-1110	C-3	92110-1147	G-10	92151-1134	B-9
92015-1555	B-11	92033-1186	F-5	92049-0022	E-3	92066-1174	C-6	92110-1148	G-10	92151-1134	C-5
92015-1602	H-5	92033-1186	F-7	92049-0073	F-10	92066-1211	B-6	92111-1051	G-10	92151-1135	C-5

This catalog covers:

'07~'08 ZR750 L7F/L8F

GRID NO.

This grid covers:

L-16

Numerical Parts Index

Part No.	Grid No.	Part No.	Grid No.	Part No.	Grid No.	Part No.	Grid No.	Part No.	Grid No.	Part No.	Grid No.
92151-1149	E-7	92153-0424	C-10	92153-1872	F-6	92171-0776	F-7	92180-1054	B-8	92210-0062	E-3
92151-1221	B-4	92153-0425	F-10	92153-1873	E-10	92171-0815	B-6	92191-0019	B-6	92210-0077	E-3
92151-1222	C-4	92153-0474	E-3	92153-1899	E-4	92171-0864	D-3	92191-0025	C-7	92210-0116	E-7
92151-1223	C-4	92153-0484	F-10	92160-1116	B-7	92171-0920	B-4	92191-0036	C-7	92210-0117	E-7
92151-1226	B-14	92153-0506	F-10	92160-1167	E-5	92171-0926	C-6	92191-1001	E-11	92210-0121	B-7
92151-1234	C-10	92153-0549	C-12	92160-1167	F-14	92171-0930	C-11	92191-1739	F-3	92210-0159	B-7
92151-1235	C-10	92153-0559	E-4	92160-1278	E-10	92171-0931	C-11	92191-1776	C-3	92210-0276	E-14
92151-1335	C-13	92153-0578	B-7	92160-1613	E-5	92171-1420	C-10	92191-1783	B-6	92210-0318	E-6
92151-1378	C-4	92153-0589	E-10	92160-1613	G-4	92171-1539	B-6	92192-0018	C-7	92210-0321	E-8
92151-1535	E-4	92153-0684	G-6	92160-1613	G-5	92171-1539	C-9	92192-0019	C-7	92210-1100	B-14
92151-1539	C-4	92153-0702	B-7	92160-1868	C-3	92171-1552	B-3	92192-0033	B-6	92210-1101	B-14
92151-1599	F-11	92153-0753	C-3	92161-0037	F-9	92171-1666	G-3	92192-0321	B-6	92210-1121	B-7
92151-1611	B-7	92153-0816	E-5	92161-0041	C-9	92171-1667	F-5	92192-0479	F-11	92210-1150	E-8
92151-1611	H-6	92153-0816	G-4	92161-0046	F-13	92172-0006	G-5	92192-0593	F-11	92210-1203	E-4
92151-1626	C-11	92153-0858	E-4	92161-0054	G-5	92172-0006	H-5	92200-0001	F-10	92210-1266	H-6
92151-1774	C-3	92153-0906	G-8	92161-0063	E-5	92172-0009	B-6	92200-0006	E-5	92210-1347	E-7
92151-1774	C-9	92153-1089	F-6	92161-0147	E-5	92172-0056	B-6	92200-0043	E-9	92210-1397	E-7
92151-1924	E-5	92153-1098	E-4	92161-0148	E-5	92172-0056	G-6	92200-0078	B-7	99901-0004-01	H-7
92151-1930	B-9	92153-1244	E-5	92161-0149	F-13	92172-0064	C-7	92200-0081	E-3	99903-0004-01	H-7
92151-1930	C-13	92153-1244	G-4	92161-0191	G-6	92172-0065	C-7	92200-0085	F-10	99924-1381-01	H-7
92151-1946	G-9	92153-1267	E-10	92161-0240	G-9	92172-0090	C-3	92200-0114	B-3	99939-1321-01	H-7
92151-1982	G-9	92153-1283	C-8	92161-0257	G-9	92172-0175	H-6	92200-0115	C-4	99946-1041-01	H-7
92151-1997	D-3	92153-1361	F-7	92161-0281	E-6	92172-0183	F-9	92200-0164	G-7	99950-1046-01	H-7
92151-2130	B-7	92153-1419	F-5	92161-0317	G-6	92172-0188	G-9	92200-0165	G-7	99951-1032-01	H-7
92152-0070	E-14	92153-1419	F-7	92161-0342	E-14	92172-1060	F-9	92200-0212	G-9	99952-1016-01	H-7
92152-0087	E-13	92153-1424	G-6	92161-0356	C-9	92172-1061	F-13	92200-0281	E-3	99953-1038-01	H-7
92152-0092	G-6	92153-1438	F-5	92161-0492	C-5	92172-1061	H-5	92200-0284	G-4	99954-1047-01	H-7
92152-0103	F-9	92153-1505	B-14	92161-0533	E-5	92180-0276	B-8	92200-0284	G-6	99955-1030-01	H-7
92152-0118	E-14	92153-1526	E-6	92161-1170	B-7	92180-0277	B-8	92200-0288	F-13	99956-1014-01	H-7
92152-0134	C-9	92153-1546	E-8	92161-1300	B-14	92180-0278	B-8	92200-0366	C-10	99976-1306	H-7
92152-0136	E-7	92153-1569	C-6	92161-1313	G-6	92180-1014	B-8	92200-0369	C-11	99976-1362	H-7
92152-0177	B-12	92153-1574	C-5	92170-1090	F-5	92180-1016	B-8	92200-0400	B-7	99976-1409	H-7
92152-0188	B-7	92153-1584	C-14	92170-1091	F-5	92180-1018	B-8	92200-0414	G-4	99976-1410	H-7
92152-0310	E-13	92153-1612	E-10	92170-1091	F-7	92180-1020	B-8	92200-1009	C-10	99986-1357	H-7
92152-0352	G-9	92153-1612	E-6	92170-1118	C-3	92180-1022	B-8	92200-1042	E-4	99986-1436	H-7
92152-0372	G-6	92153-1612	F-13	92170-1492	F-11	92180-1024	B-8	92200-1042	E-8	99999-0111	C-7
92152-0445	H-6	92153-1612	G-4	92170-1577	C-3	92180-1026	B-8	92200-1065	B-12	99999-0112	C-7
92152-0559	E-14	92153-1612	H-5	92170-1577	C-5	92180-1028	B-8	92200-1239	B-12		
92152-0577	E-10	92153-1612	H-6	92170-1577	C-6	92180-1030	B-8	92200-1375	B-12		
92152-0600	E-5	92153-1616	F-11	92170-1804	H-6	92180-1032	B-8	92200-1388	E-10		
92152-1074	C-14	92153-1624	E-5	92171-0067	C-5	92180-1034	B-8	92200-1423	B-11		
92152-1074	E-5	92153-1624	F-7	92171-0092	C-3	92180-1036	B-8	92200-1457	B-12		
92152-1167	B-9	92153-1662	E-8	92171-0133	B-7	92180-1038	B-8	92200-1487	B-11		
92152-1383	B-14	92153-1818	E-4	92171-0141	E-7	92180-1040	B-8	92200-1489	E-14		
92153-0332	B-11	92153-1819	E-4	92171-0179	D-3	92180-1042	B-8	92200-1522	B-12		
92153-0370	H-5	92153-1820	E-4	92171-0180	D-3	92180-1044	B-8	92200-1523	B-12		
92153-0410	E-5	92153-1826	F-8	92171-0292	B-7	92180-1046	B-8	92200-1524	B-12		
92153-0410	G-8	92153-1837	E-8	92171-0302	C-3	92180-1048	B-8	92200-3780	B-7		
92153-0410	G-9	92153-1855	C-11	92171-0489	F-7	92180-1050	B-8	92210-0006	F-9		
92153-0421	B-14	92153-1871	E-11	92171-0708	C-5	92180-1052	B-8	92210-0007	G-9		

This catalog covers:

'07~'08 ZR750 L7F/L8F

GRID NO.

B-16

This grid covers:

Part Name Index

Air Cleaner.....	B-6
Battery Case.....	E-6
Brake Pedal.....	F-3
Cables.....	G-3
Camshaft(s).....	B-9
Chain Cover.....	G-4
Chassis Electrical Equipment.....	G-8
Clutch.....	B-11
Cowling.....	H-5
Cowling Lowers.....	H-6
Crankcase.....	C-3
Crankcase Bolt Pattern.....	C-4
Crankshaft.....	B-10
Cylinder.....	B-5
Cylinder Head.....	B-3
Cylinder Head Cover.....	B-4
Decals(Blue)(L8F).....	H-3
Decals(Ebony).....	G-14
Decals(Green)(L7F).....	G-13
Decals(Orange)(L8F).....	H-4
Decals(Silver)(L7F).....	G-12
Engine Cover(s).....	C-5
Engine Mount.....	E-4
Fenders.....	E-10
Footrests.....	E-9
Frame.....	E-3
Frame Fittings.....	E-5
Front Brake.....	F-6
Front Fork.....	F-10
Front Hub.....	E-13
Front Master Cylinder.....	F-5
Fuel Injection.....	C-9
Fuel Pump.....	C-8
Fuel Tank.....	F-11
Gear Change Drum.....	B-13

Gear Change Mechanism.....	B-14
Generator.....	C-11
Handlebar.....	F-9
Headlight(s).....	G-5
Ignition Switch.....	G-9
Ignition System.....	C-12
Labels.....	G-11
Manual.....	H-7
Meter(s).....	F-14
Muffler(s).....	B-7
Oil Pan.....	C-6
Oil Pump.....	C-10
Owner's Tools.....	G-10
Piston(s).....	B-5
Radiator.....	C-14
Rear Brake.....	F-8
Rear Hub.....	E-14
Rear Master Cylinder.....	F-7
Seat.....	F-12/F-13
Shift Fork(s).....	B-13
Shock Absorber(s).....	F-4
Side Covers.....	G-4
Stand(s).....	E-11
Starter Motor.....	C-13
Suspension.....	E-8
Swingarm.....	E-7
Taillight(s).....	G-6
Tensioner.....	B-9
Throttle.....	C-7
Tires.....	E-12
Transmission.....	B-12
Turn Signals.....	G-7
Valve(s).....	B-8
Water Pipe.....	D-3

This catalog covers:

'07~'08 ZR750 L7F/L8F

GRID NO.

C-16

This grid covers:

Part Name Index

Air Cleaner.....	B-6
Battery Case.....	E-6
Brake Pedal.....	F-3
Cables.....	G-3
Camshaft(s).....	B-9
Chain Cover.....	G-4
Chassis Electrical Equipment.....	G-8
Clutch.....	B-11
Cowling.....	H-5
Cowling Lowers.....	H-6
Crankcase.....	C-3
Crankcase Bolt Pattern.....	C-4
Crankshaft.....	B-10
Cylinder.....	B-5
Cylinder Head.....	B-3
Cylinder Head Cover.....	B-4
Decals(Blue)(L8F).....	H-3
Decals(Ebony).....	G-14
Decals(Green)(L7F).....	G-13
Decals(Orange)(L8F).....	H-4
Decals(Silver)(L7F).....	G-12
Engine Cover(s).....	C-5
Engine Mount.....	E-4
Fenders.....	E-10
Footrests.....	E-9
Frame.....	E-3
Frame Fittings.....	E-5
Front Brake.....	F-6
Front Fork.....	F-10
Front Hub.....	E-13
Front Master Cylinder.....	F-5
Fuel Injection.....	C-9
Fuel Pump.....	C-8
Fuel Tank.....	F-11
Gear Change Drum.....	B-13

Gear Change Mechanism.....	B-14
Generator.....	C-11
Handlebar.....	F-9
Headlight(s).....	G-5
Ignition Switch.....	G-9
Ignition System.....	C-12
Labels.....	G-11
Manual.....	H-7
Meter(s).....	F-14
Muffler(s).....	B-7
Oil Pan.....	C-6
Oil Pump.....	C-10
Owner's Tools.....	G-10
Piston(s).....	B-5
Radiator.....	C-14
Rear Brake.....	F-8
Rear Hub.....	E-14
Rear Master Cylinder.....	F-7
Seat.....	F-12/F-13
Shift Fork(s).....	B-13
Shock Absorber(s).....	F-4
Side Covers.....	G-4
Stand(s).....	E-11
Starter Motor.....	C-13
Suspension.....	E-8
Swingarm.....	E-7
Taillight(s).....	G-6
Tensioner.....	B-9
Throttle.....	C-7
Tires.....	E-12
Transmission.....	B-12
Turn Signals.....	G-7
Valve(s).....	B-8
Water Pipe.....	D-3

This catalog covers:

'07~'08 ZR750 L7F/L8F

GRID NO.

D-16

This grid covers:

Part Name Index

Air Cleaner.....	B-6
Battery Case.....	E-6
Brake Pedal.....	F-3
Cables.....	G-3
Camshaft(s).....	B-9
Chain Cover.....	G-4
Chassis Electrical Equipment.....	G-8
Clutch.....	B-11
Cowling.....	H-5
Cowling Lowers.....	H-6
Crankcase.....	C-3
Crankcase Bolt Pattern.....	C-4
Crankshaft.....	B-10
Cylinder.....	B-5
Cylinder Head.....	B-3
Cylinder Head Cover.....	B-4
Decals(Blue)(L8F).....	H-3
Decals(Ebony).....	G-14
Decals(Green)(L7F).....	G-13
Decals(Orange)(L8F).....	H-4
Decals(Silver)(L7F).....	G-12
Engine Cover(s).....	C-5
Engine Mount.....	E-4
Fenders.....	E-10
Footrests.....	E-9
Frame.....	E-3
Frame Fittings.....	E-5
Front Brake.....	F-6
Front Fork.....	F-10
Front Hub.....	E-13
Front Master Cylinder.....	F-5
Fuel Injection.....	C-9
Fuel Pump.....	C-8
Fuel Tank.....	F-11
Gear Change Drum.....	B-13

Gear Change Mechanism.....	B-14
Generator.....	C-11
Handlebar.....	F-9
Headlight(s).....	G-5
Ignition Switch.....	G-9
Ignition System.....	C-12
Labels.....	G-11
Manual.....	H-7
Meter(s).....	F-14
Muffler(s).....	B-7
Oil Pan.....	C-6
Oil Pump.....	C-10
Owner's Tools.....	G-10
Piston(s).....	B-5
Radiator.....	C-14
Rear Brake.....	F-8
Rear Hub.....	E-14
Rear Master Cylinder.....	F-7
Seat.....	F-12/F-13
Shift Fork(s).....	B-13
Shock Absorber(s).....	F-4
Side Covers.....	G-4
Stand(s).....	E-11
Starter Motor.....	C-13
Suspension.....	E-8
Swingarm.....	E-7
Taillight(s).....	G-6
Tensioner.....	B-9
Throttle.....	C-7
Tires.....	E-12
Transmission.....	B-12
Turn Signals.....	G-7
Valve(s).....	B-8
Water Pipe.....	D-3

This catalog covers:

'07~'08 ZR750 L7F/L8F

GRID NO.

E-16

This grid covers:

Part Name Index

Air Cleaner.....	B-6
Battery Case.....	E-6
Brake Pedal.....	F-3
Cables.....	G-3
Camshaft(s).....	B-9
Chain Cover.....	G-4
Chassis Electrical Equipment.....	G-8
Clutch.....	B-11
Cowling.....	H-5
Cowling Lowers.....	H-6
Crankcase.....	C-3
Crankcase Bolt Pattern.....	C-4
Crankshaft.....	B-10
Cylinder.....	B-5
Cylinder Head.....	B-3
Cylinder Head Cover.....	B-4
Decals(Blue)(L8F).....	H-3
Decals(Ebony).....	G-14
Decals(Green)(L7F).....	G-13
Decals(Orange)(L8F).....	H-4
Decals(Silver)(L7F).....	G-12
Engine Cover(s).....	C-5
Engine Mount.....	E-4
Fenders.....	E-10
Footrests.....	E-9
Frame.....	E-3
Frame Fittings.....	E-5
Front Brake.....	F-6
Front Fork.....	F-10
Front Hub.....	E-13
Front Master Cylinder.....	F-5
Fuel Injection.....	C-9
Fuel Pump.....	C-8
Fuel Tank.....	F-11
Gear Change Drum.....	B-13

Gear Change Mechanism.....	B-14
Generator.....	C-11
Handlebar.....	F-9
Headlight(s).....	G-5
Ignition Switch.....	G-9
Ignition System.....	C-12
Labels.....	G-11
Manual.....	H-7
Meter(s).....	F-14
Muffler(s).....	B-7
Oil Pan.....	C-6
Oil Pump.....	C-10
Owner's Tools.....	G-10
Piston(s).....	B-5
Radiator.....	C-14
Rear Brake.....	F-8
Rear Hub.....	E-14
Rear Master Cylinder.....	F-7
Seat.....	F-12/F-13
Shift Fork(s).....	B-13
Shock Absorber(s).....	F-4
Side Covers.....	G-4
Stand(s).....	E-11
Starter Motor.....	C-13
Suspension.....	E-8
Swingarm.....	E-7
Taillight(s).....	G-6
Tensioner.....	B-9
Throttle.....	C-7
Tires.....	E-12
Transmission.....	B-12
Turn Signals.....	G-7
Valve(s).....	B-8
Water Pipe.....	D-3

This catalog covers:

'07~'08 ZR750 L7F/L8F

GRID NO.

F-16

This grid covers:

Part Name Index

Air Cleaner.....	B-6
Battery Case.....	E-6
Brake Pedal.....	F-3
Cables.....	G-3
Camshaft(s).....	B-9
Chain Cover.....	G-4
Chassis Electrical Equipment.....	G-8
Clutch.....	B-11
Cowling.....	H-5
Cowling Lowers.....	H-6
Crankcase.....	C-3
Crankcase Bolt Pattern.....	C-4
Crankshaft.....	B-10
Cylinder.....	B-5
Cylinder Head.....	B-3
Cylinder Head Cover.....	B-4
Decals(Blue)(L8F).....	H-3
Decals(Ebony).....	G-14
Decals(Green)(L7F).....	G-13
Decals(Orange)(L8F).....	H-4
Decals(Silver)(L7F).....	G-12
Engine Cover(s).....	C-5
Engine Mount.....	E-4
Fenders.....	E-10
Footrests.....	E-9
Frame.....	E-3
Frame Fittings.....	E-5
Front Brake.....	F-6
Front Fork.....	F-10
Front Hub.....	E-13
Front Master Cylinder.....	F-5
Fuel Injection.....	C-9
Fuel Pump.....	C-8
Fuel Tank.....	F-11
Gear Change Drum.....	B-13

Gear Change Mechanism.....	B-14
Generator.....	C-11
Handlebar.....	F-9
Headlight(s).....	G-5
Ignition Switch.....	G-9
Ignition System.....	C-12
Labels.....	G-11
Manual.....	H-7
Meter(s).....	F-14
Muffler(s).....	B-7
Oil Pan.....	C-6
Oil Pump.....	C-10
Owner's Tools.....	G-10
Piston(s).....	B-5
Radiator.....	C-14
Rear Brake.....	F-8
Rear Hub.....	E-14
Rear Master Cylinder.....	F-7
Seat.....	F-12/F-13
Shift Fork(s).....	B-13
Shock Absorber(s).....	F-4
Side Covers.....	G-4
Stand(s).....	E-11
Starter Motor.....	C-13
Suspension.....	E-8
Swingarm.....	E-7
Taillight(s).....	G-6
Tensioner.....	B-9
Throttle.....	C-7
Tires.....	E-12
Transmission.....	B-12
Turn Signals.....	G-7
Valve(s).....	B-8
Water Pipe.....	D-3

This catalog covers:

'07~'08 ZR750 L7F/L8F

GRID NO.

G-16

This grid covers:

Part Name Index

Air Cleaner.....	B-6
Battery Case.....	E-6
Brake Pedal.....	F-3
Cables.....	G-3
Camshaft(s).....	B-9
Chain Cover.....	G-4
Chassis Electrical Equipment.....	G-8
Clutch.....	B-11
Cowling.....	H-5
Cowling Lowers.....	H-6
Crankcase.....	C-3
Crankcase Bolt Pattern.....	C-4
Crankshaft.....	B-10
Cylinder.....	B-5
Cylinder Head.....	B-3
Cylinder Head Cover.....	B-4
Decals(Blue)(L8F).....	H-3
Decals(Ebony).....	G-14
Decals(Green)(L7F).....	G-13
Decals(Orange)(L8F).....	H-4
Decals(Silver)(L7F).....	G-12
Engine Cover(s).....	C-5
Engine Mount.....	E-4
Fenders.....	E-10
Footrests.....	E-9
Frame.....	E-3
Frame Fittings.....	E-5
Front Brake.....	F-6
Front Fork.....	F-10
Front Hub.....	E-13
Front Master Cylinder.....	F-5
Fuel Injection.....	C-9
Fuel Pump.....	C-8
Fuel Tank.....	F-11
Gear Change Drum.....	B-13

Gear Change Mechanism.....	B-14
Generator.....	C-11
Handlebar.....	F-9
Headlight(s).....	G-5
Ignition Switch.....	G-9
Ignition System.....	C-12
Labels.....	G-11
Manual.....	H-7
Meter(s).....	F-14
Muffler(s).....	B-7
Oil Pan.....	C-6
Oil Pump.....	C-10
Owner's Tools.....	G-10
Piston(s).....	B-5
Radiator.....	C-14
Rear Brake.....	F-8
Rear Hub.....	E-14
Rear Master Cylinder.....	F-7
Seat.....	F-12/F-13
Shift Fork(s).....	B-13
Shock Absorber(s).....	F-4
Side Covers.....	G-4
Stand(s).....	E-11
Starter Motor.....	C-13
Suspension.....	E-8
Swingarm.....	E-7
Taillight(s).....	G-6
Tensioner.....	B-9
Throttle.....	C-7
Tires.....	E-12
Transmission.....	B-12
Turn Signals.....	G-7
Valve(s).....	B-8
Water Pipe.....	D-3

This catalog covers:

'07~'08 ZR750 L7F/L8F

GRID NO.

H-16

This grid covers:

Part Name Index

Air Cleaner.....	B-6
Battery Case.....	E-6
Brake Pedal.....	F-3
Cables.....	G-3
Camshaft(s).....	B-9
Chain Cover.....	G-4
Chassis Electrical Equipment.....	G-8
Clutch.....	B-11
Cowling.....	H-5
Cowling Lowers.....	H-6
Crankcase.....	C-3
Crankcase Bolt Pattern.....	C-4
Crankshaft.....	B-10
Cylinder.....	B-5
Cylinder Head.....	B-3
Cylinder Head Cover.....	B-4
Decals(Blue)(L8F).....	H-3
Decals(Ebony).....	G-14
Decals(Green)(L7F).....	G-13
Decals(Orange)(L8F).....	H-4
Decals(Silver)(L7F).....	G-12
Engine Cover(s).....	C-5
Engine Mount.....	E-4
Fenders.....	E-10
Footrests.....	E-9
Frame.....	E-3
Frame Fittings.....	E-5
Front Brake.....	F-6
Front Fork.....	F-10
Front Hub.....	E-13
Front Master Cylinder.....	F-5
Fuel Injection.....	C-9
Fuel Pump.....	C-8
Fuel Tank.....	F-11
Gear Change Drum.....	B-13

Gear Change Mechanism.....	B-14
Generator.....	C-11
Handlebar.....	F-9
Headlight(s).....	G-5
Ignition Switch.....	G-9
Ignition System.....	C-12
Labels.....	G-11
Manual.....	H-7
Meter(s).....	F-14
Muffler(s).....	B-7
Oil Pan.....	C-6
Oil Pump.....	C-10
Owner's Tools.....	G-10
Piston(s).....	B-5
Radiator.....	C-14
Rear Brake.....	F-8
Rear Hub.....	E-14
Rear Master Cylinder.....	F-7
Seat.....	F-12/F-13
Shift Fork(s).....	B-13
Shock Absorber(s).....	F-4
Side Covers.....	G-4
Stand(s).....	E-11
Starter Motor.....	C-13
Suspension.....	E-8
Swingarm.....	E-7
Taillight(s).....	G-6
Tensioner.....	B-9
Throttle.....	C-7
Tires.....	E-12
Transmission.....	B-12
Turn Signals.....	G-7
Valve(s).....	B-8
Water Pipe.....	D-3