

This catalog covers:

'04~'05 KSV700-A1/A2

GRID NO.

A-1

This grid covers:

Title



PARTS CATALOG

'04~'05 KSV700-A1/A2

(KFX700)

Publications	A-2
Model Identification	A-4
Engine	B-1
Chassis	E-1

© Kawasaki Heavy Industries, Ltd. 2004

Engine No. Location:

RH hand lower part of the crankcase

Year & Model

'04 KSV700-A1

'05 KSV700-A2

Color

- 1. Colored Plastic Blazing Orange (268)
- 2. Lime Green (7F)

- 1. Colored Plastic Blazing Orange (268)
- 2. Lime Green (777)

VIN No. Range

JKASV700AAB600001 ~ 602000
 JKASV6A1√4B500001 ~ 510000 (Australia only)

JKASV700AAB602001 ~
 JKASV6A1√5B510001 ~ (Australia only)

Engine No. Range

SV700AE500001 ~

SV700AE500001 ~

This catalog covers:

'04~'05 KSV700-A1/A2

GRID NO.

A-2

This grid covers:

Publications

Year & Model	Owner's Manual	A&P Manual		Service Manual		Microfiche
		General	Supplement	Basic	Supplement	
2004 KSV700-A1	99977-1178 99986-1150(Australia only)	99931-1420-01		99924-1315-02		99912-1152-03
2005 KSV700-A2	Local Procurement 99986-1222(Australia only)	See above		See above		See above

This catalog covers:

'04~'05 KSV700-A1/A2

GRID NO.

A-4

This grid covers:

Model I.D. '04~'05 KSV700-A1/A2

KSV700-A1

Left Side View

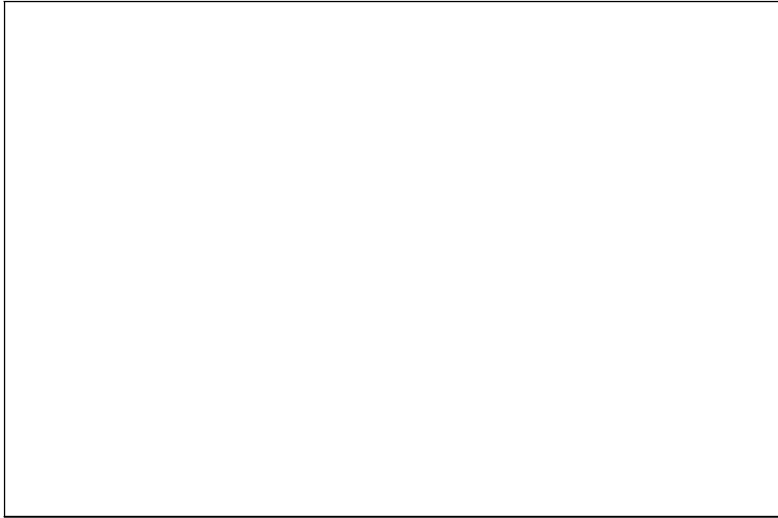

Right Side View

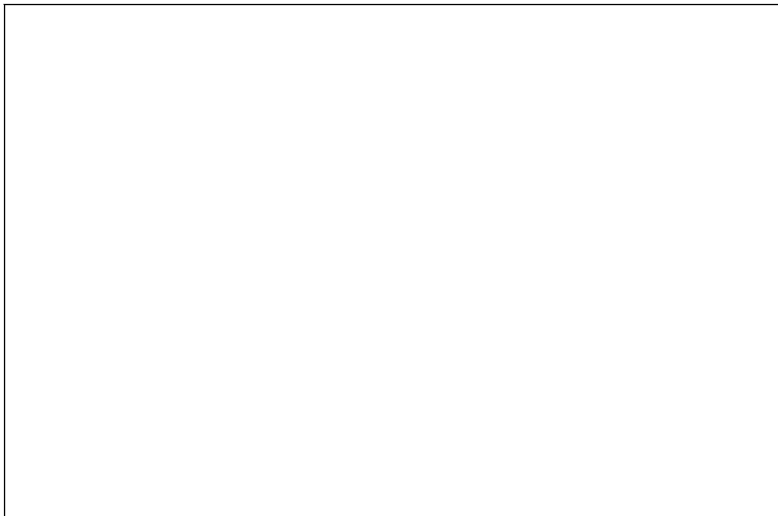

KSV700-A2

Left Side View

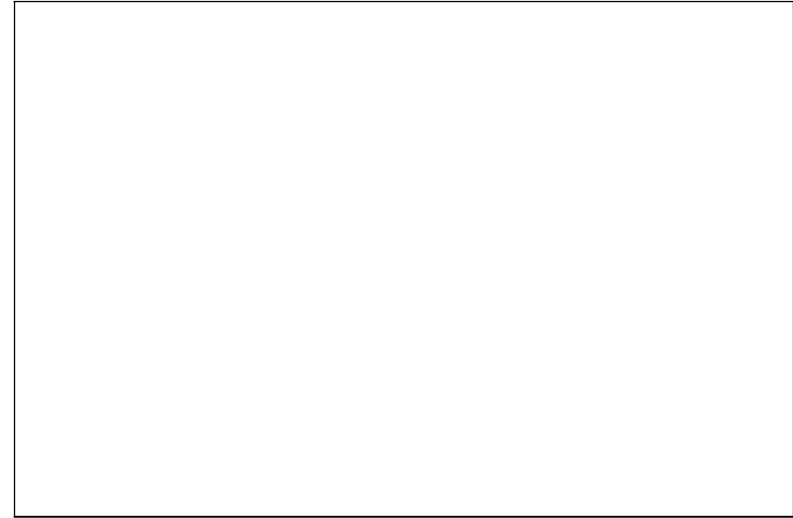

Right Side View

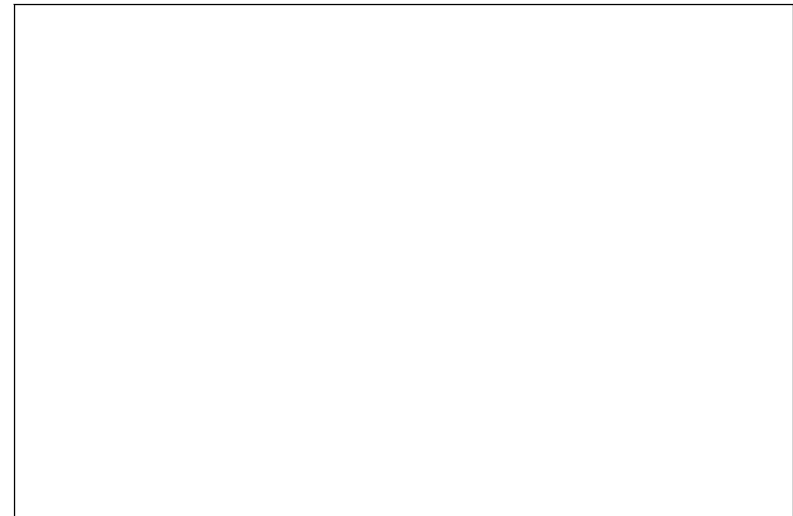

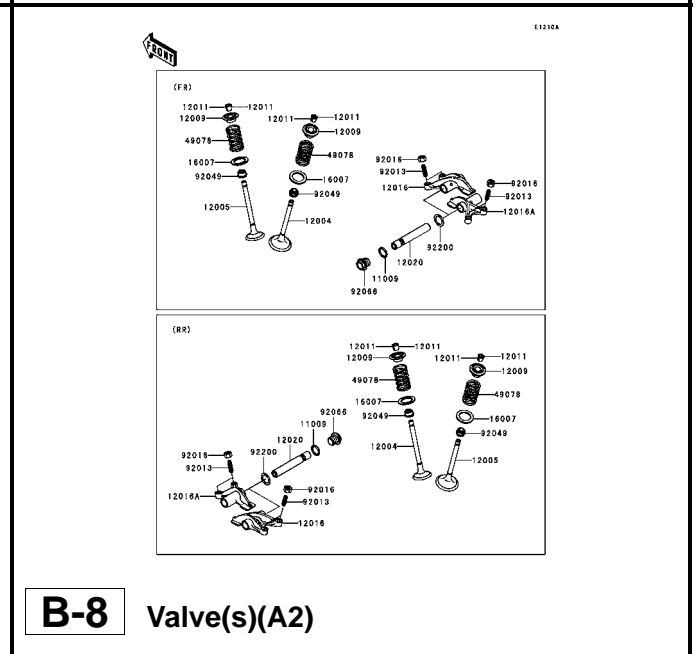
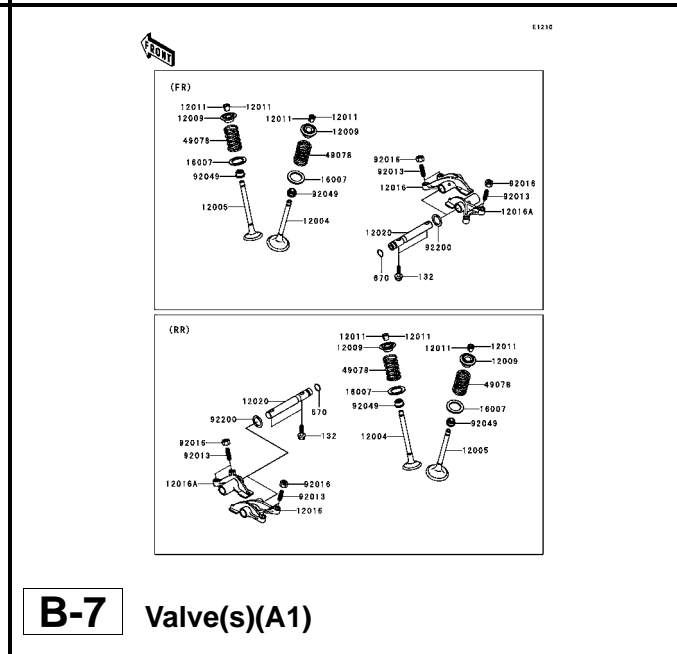
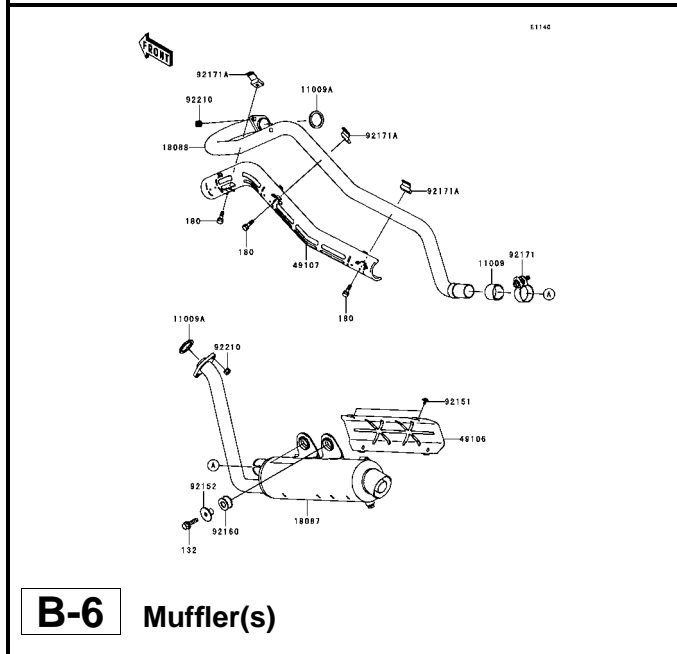
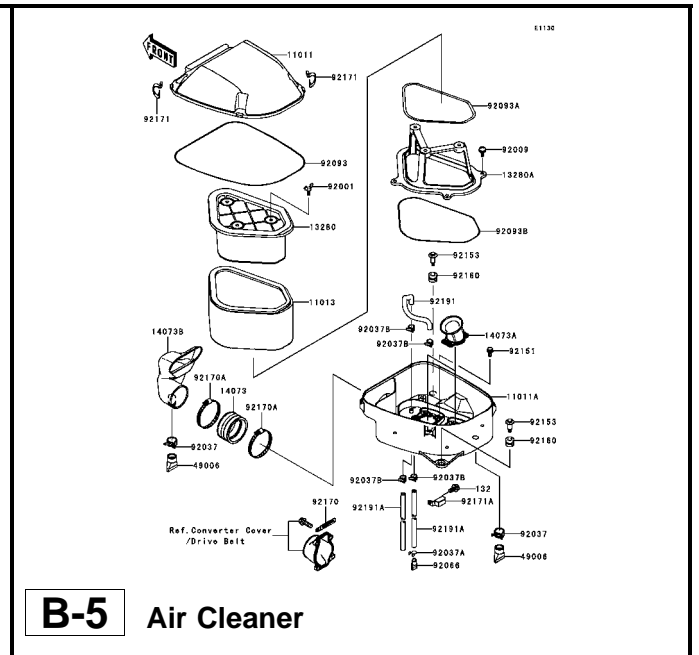
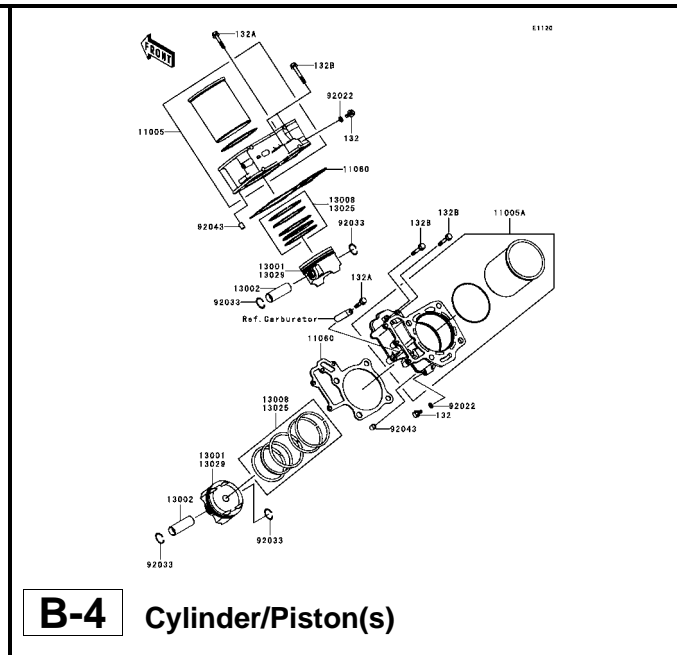
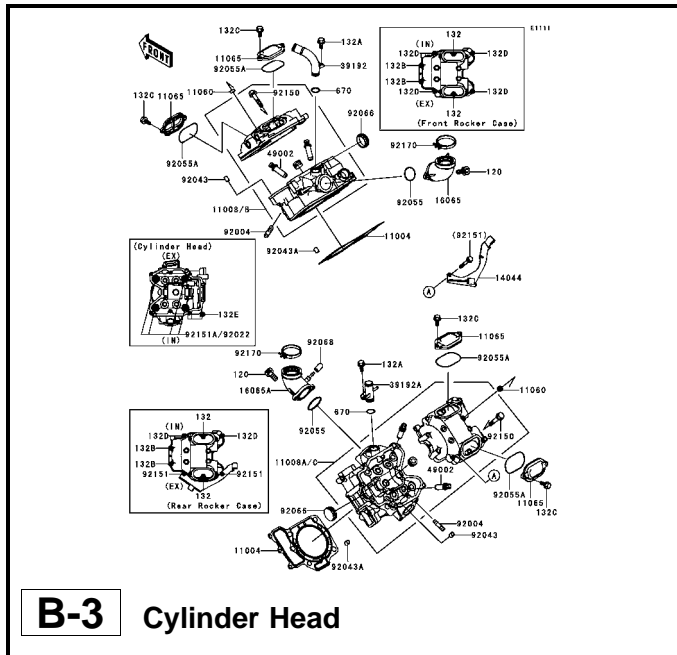

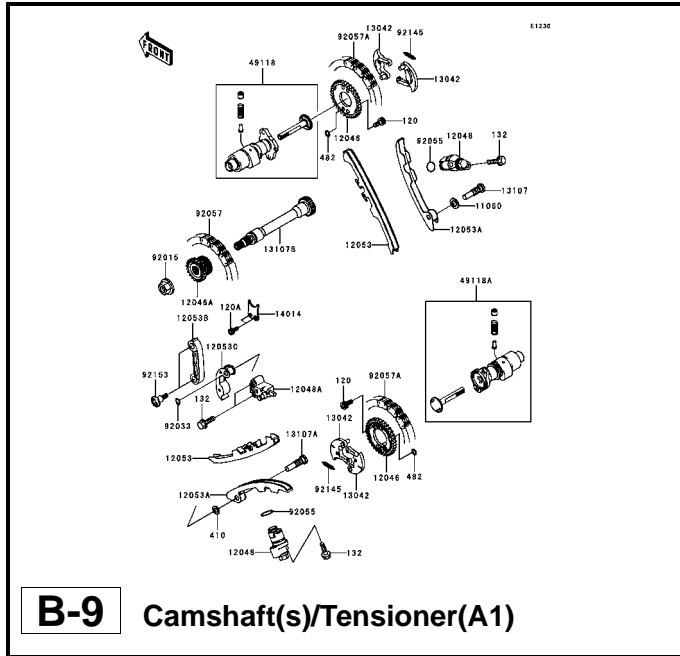

B-9 Camshaft(s)/Tensioner(A1)

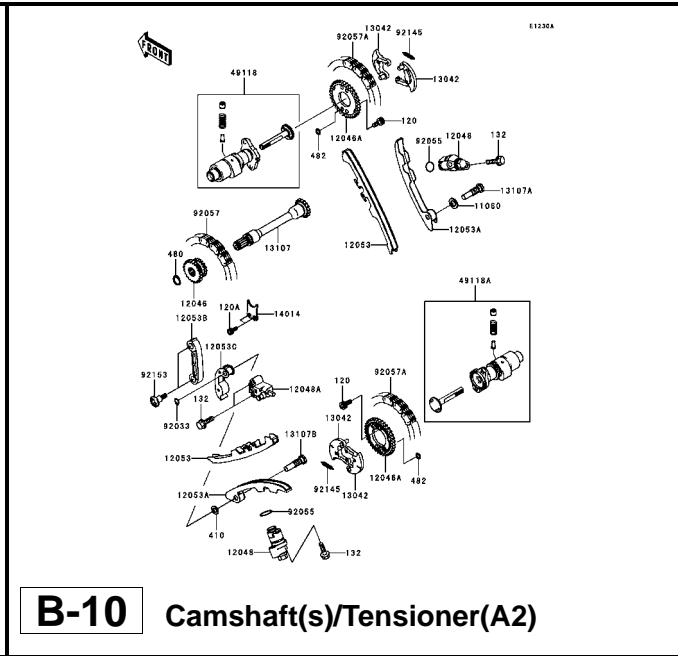

B-10 Camshaft(s)/Tensioner(A2)

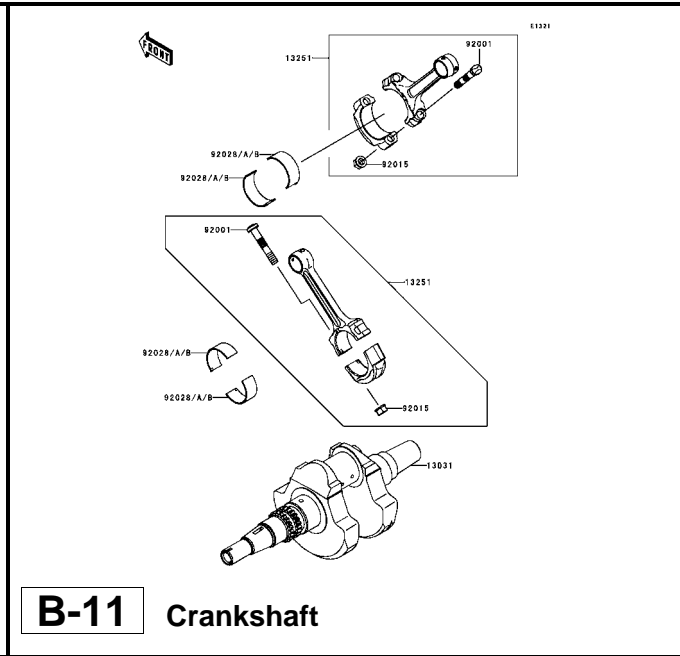

B-11 Crankshaft

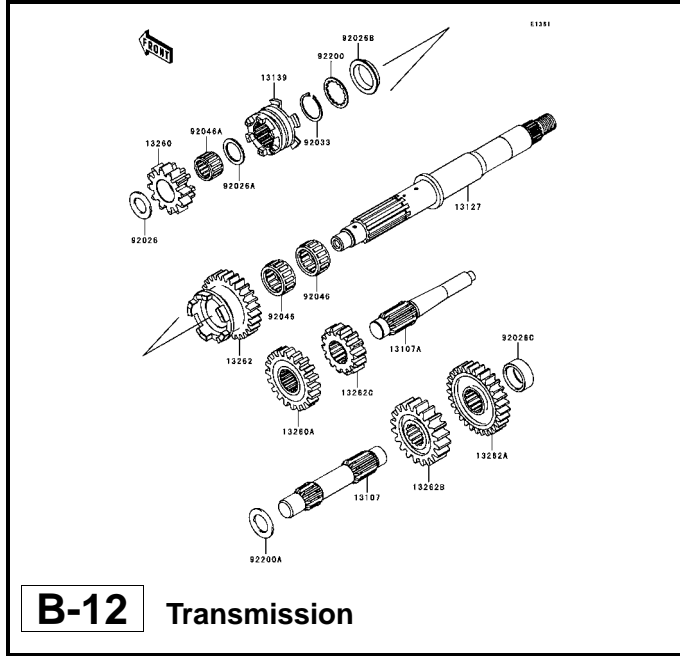

B-12 Transmission

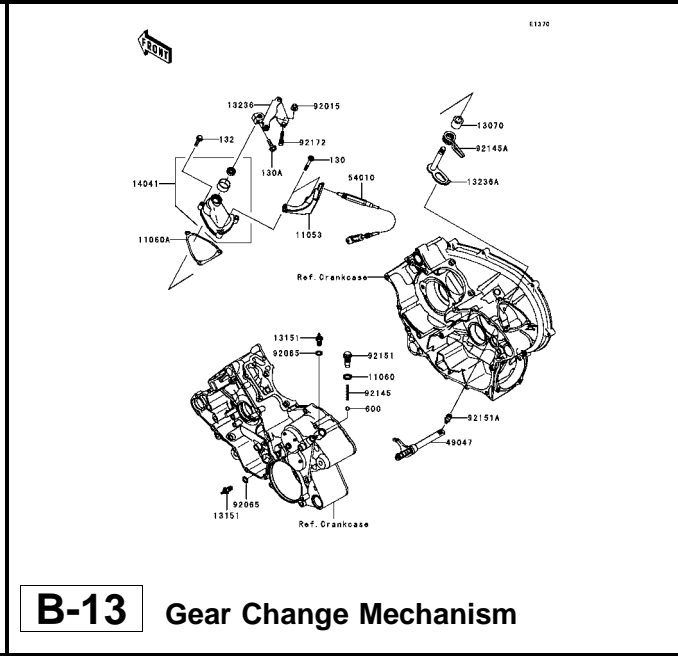

B-13 Gear Change Mechanism

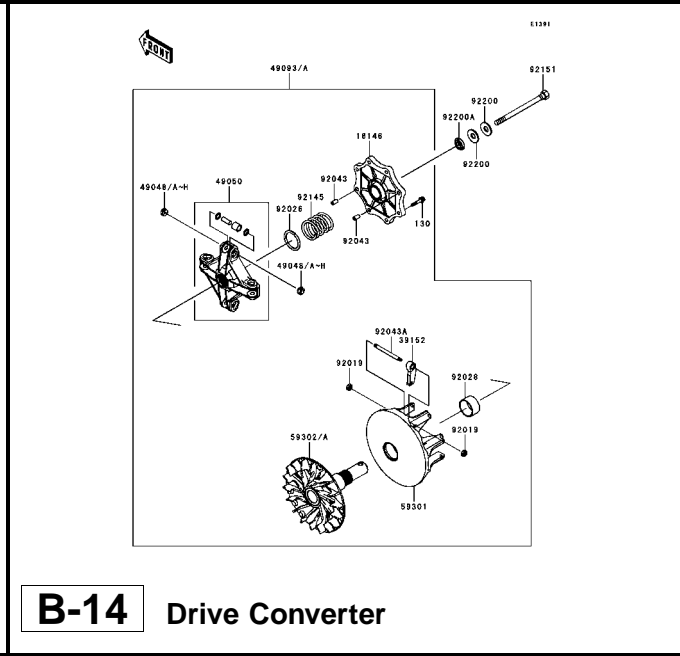

B-14 Drive Converter

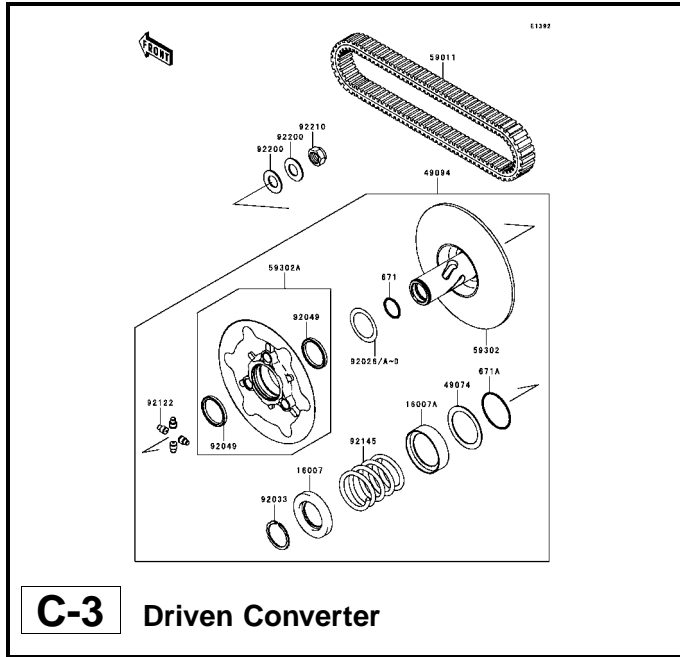

C-3 Driven Converter

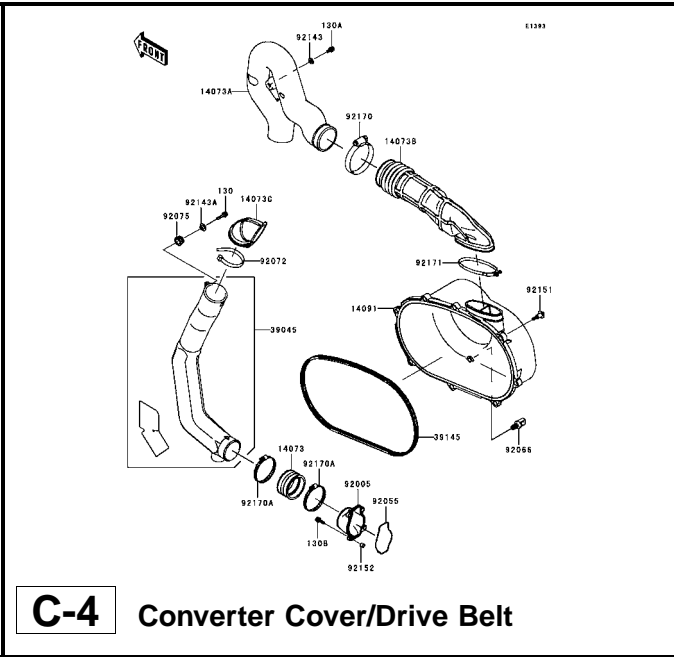

C-4 Converter Cover/Drive Belt

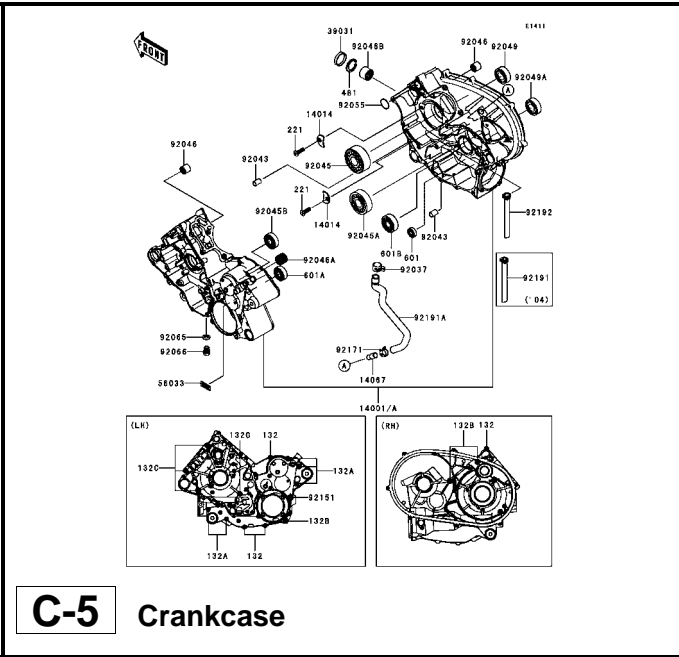

C-5 Crankcase

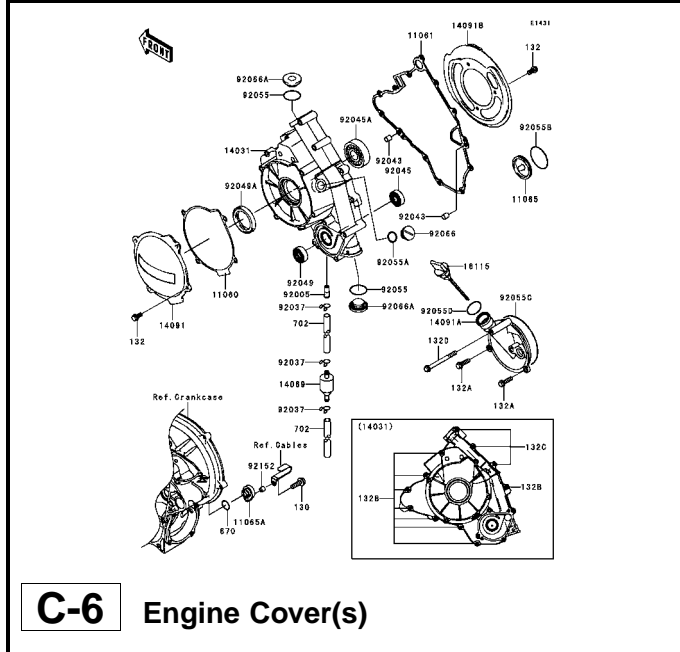

C-6 Engine Cover(s)

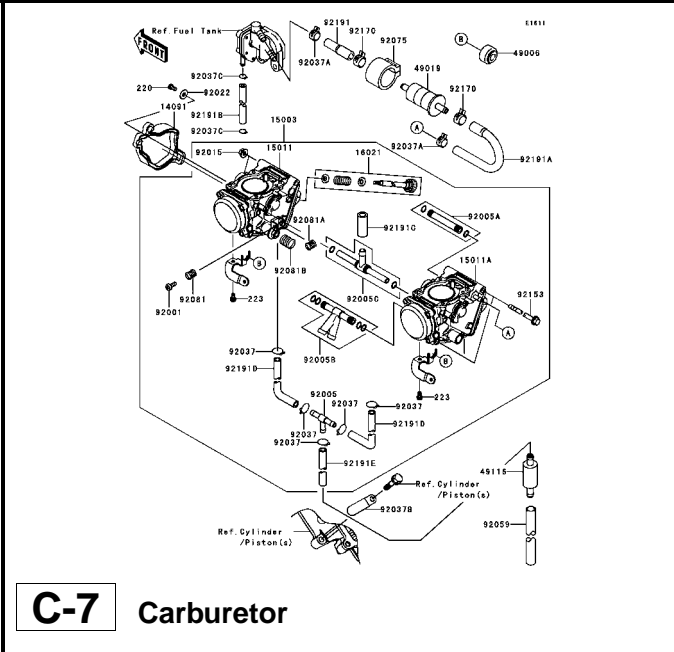

C-7 Carburetor

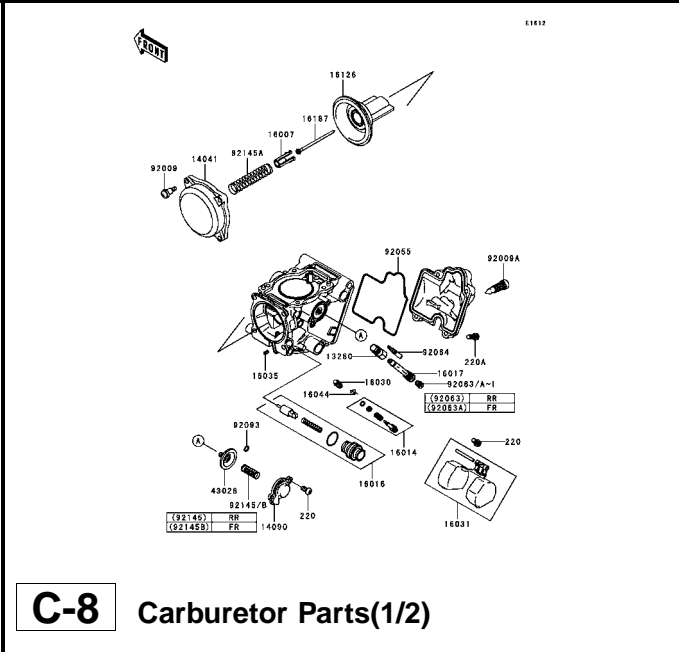

C-8 Carburetor Parts(1/2)

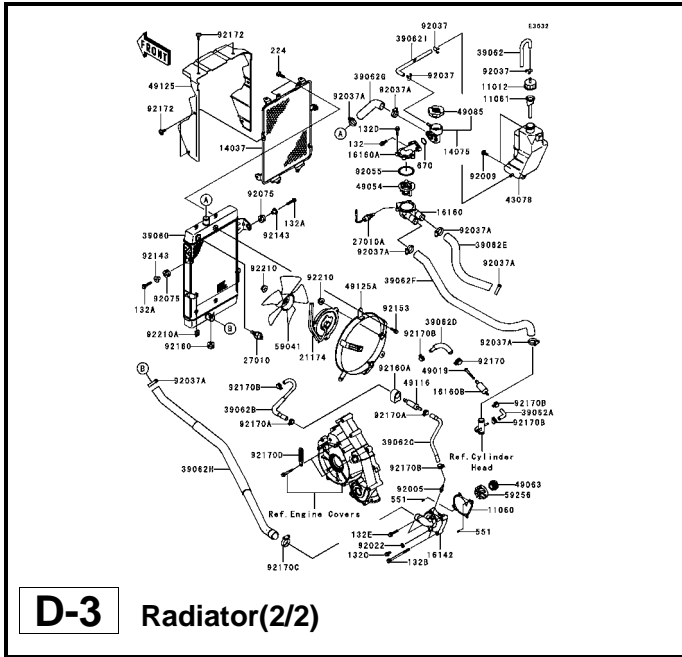

D-3 Radiator(2/2)

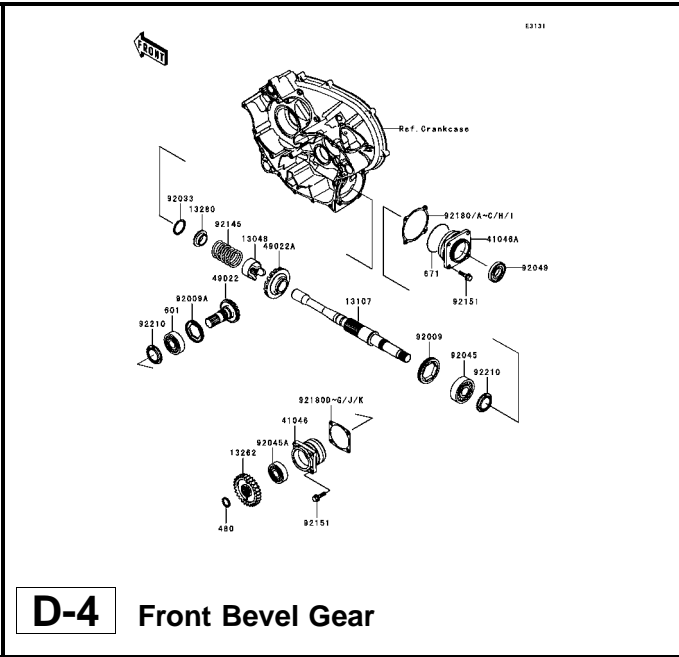

D-4 Front Bevel Gear

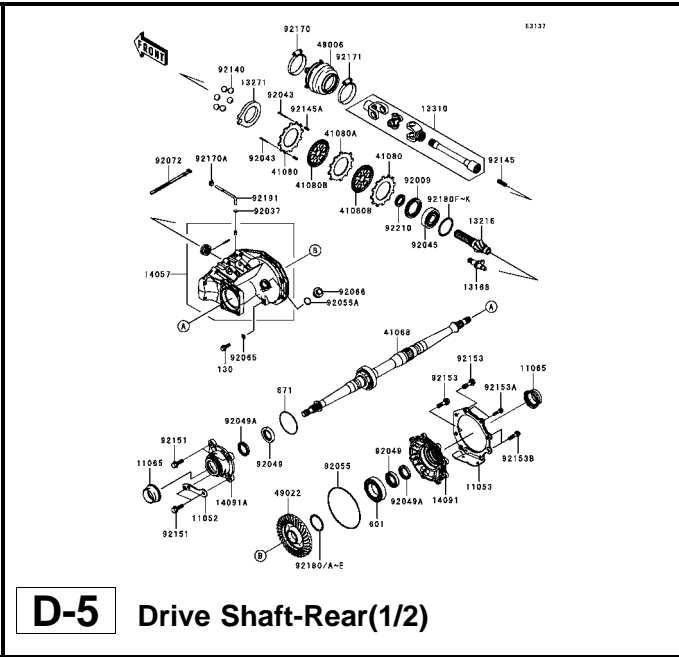

This catalog covers:

'04~'05 KSV700-A1/A2 Engine

GRID NO.

D-2

This grid covers:

Pictorial Index

This catalog covers:

'04~'05 KSV700-A1/A2 Chassis

GRID NO.

F-1

This grid covers:

Pictorial Index

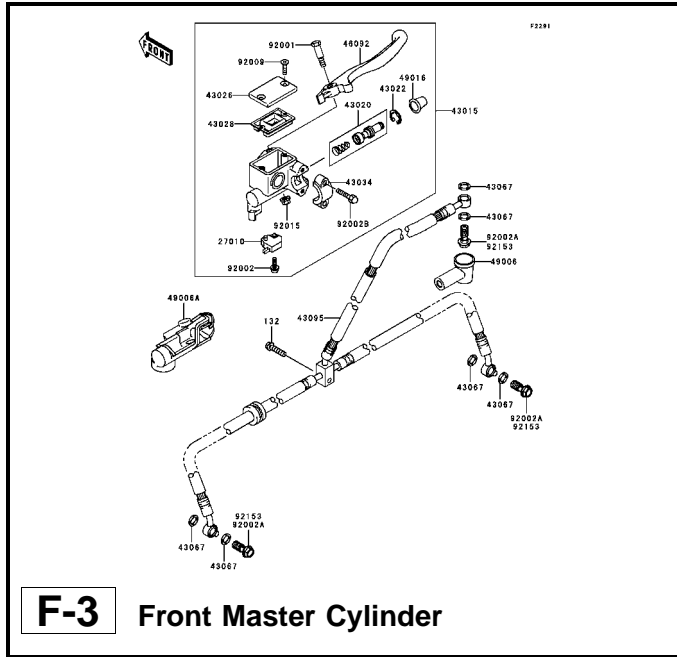

F-3 Front Master Cylinder

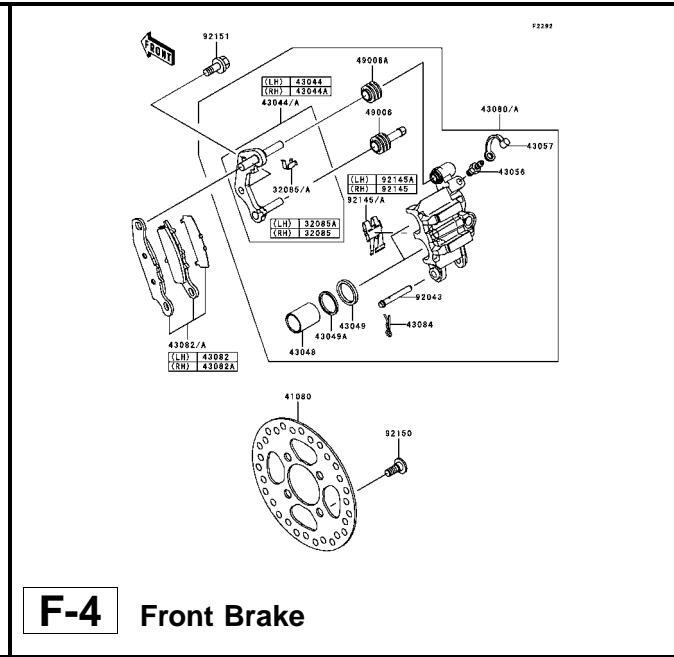

F-4 Front Brake

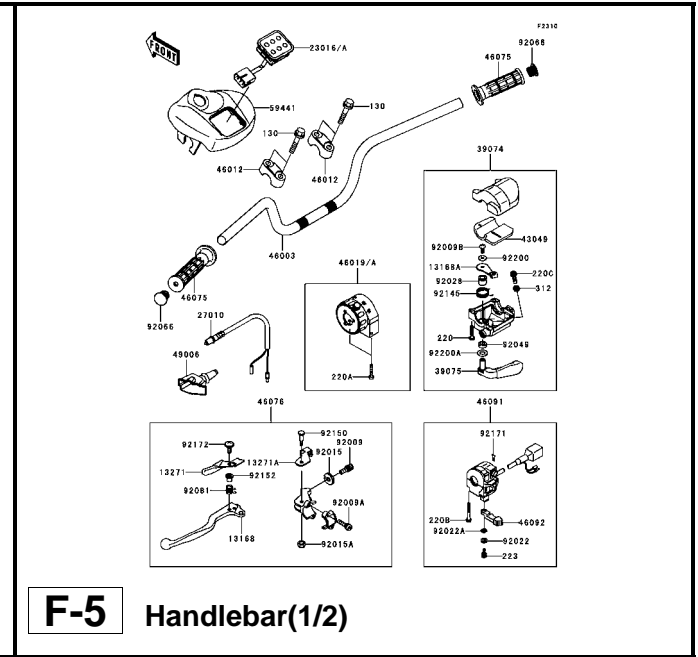

F-5 Handlebar(1/2)

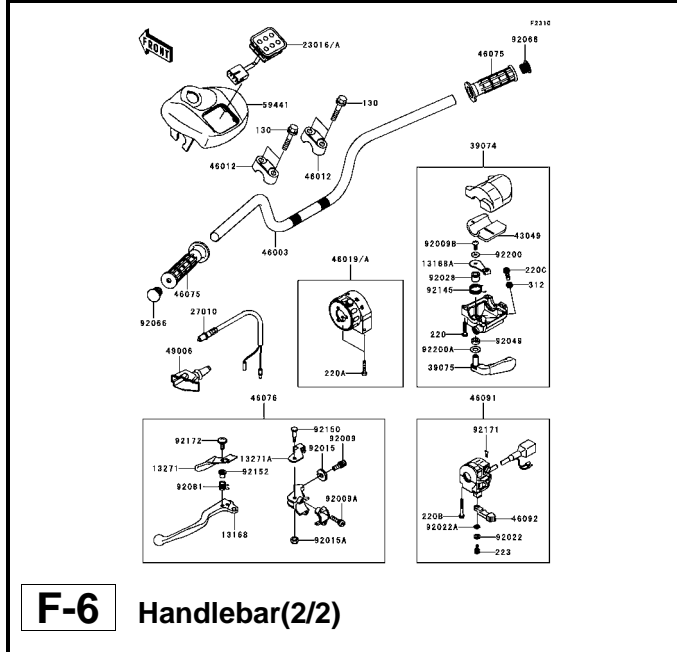

F-6 Handlebar(2/2)

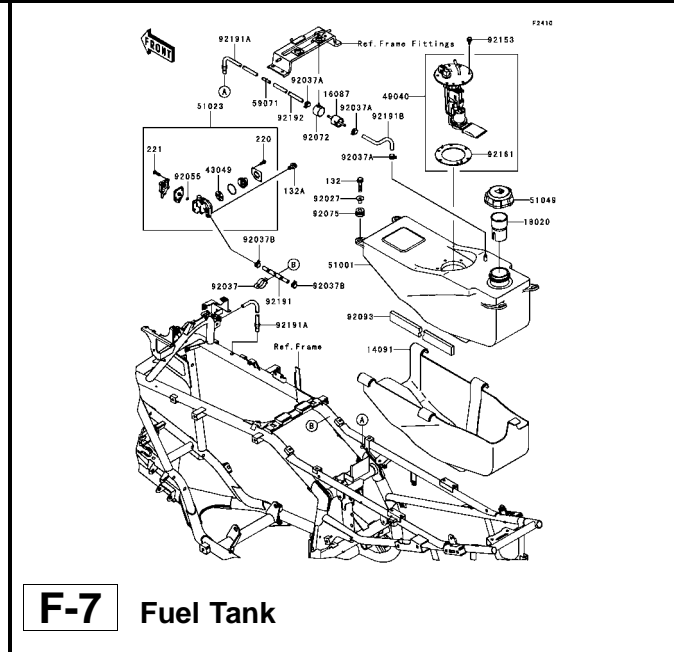

F-7 Fuel Tank

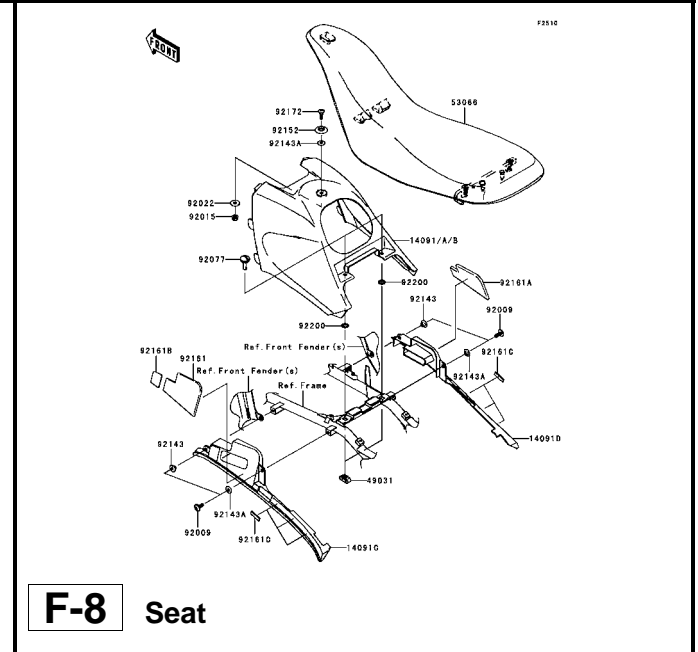

F-8 Seat

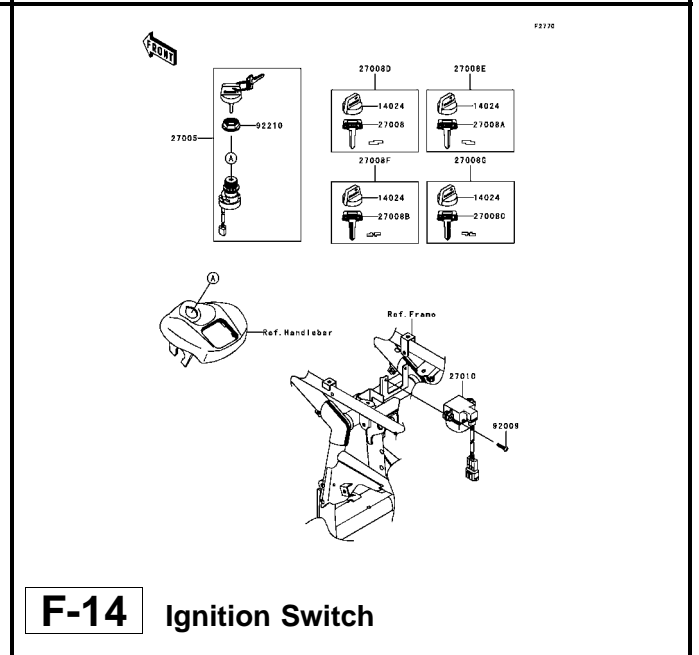
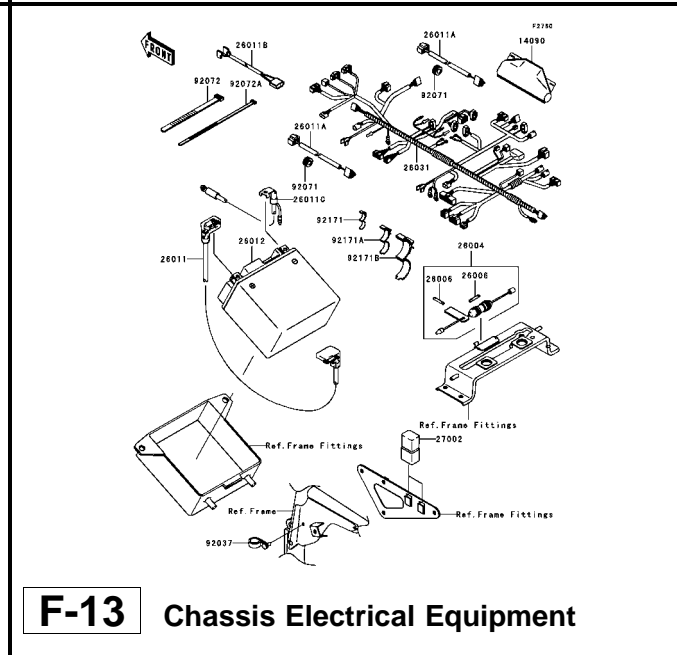
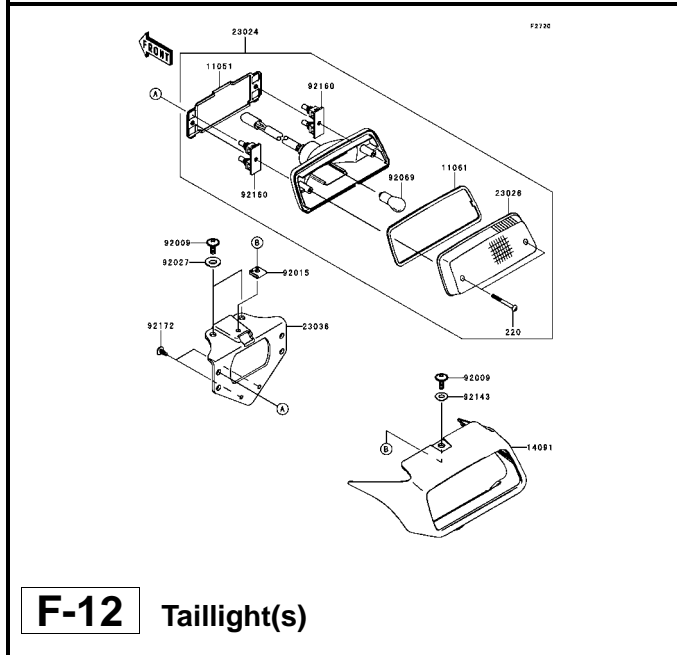
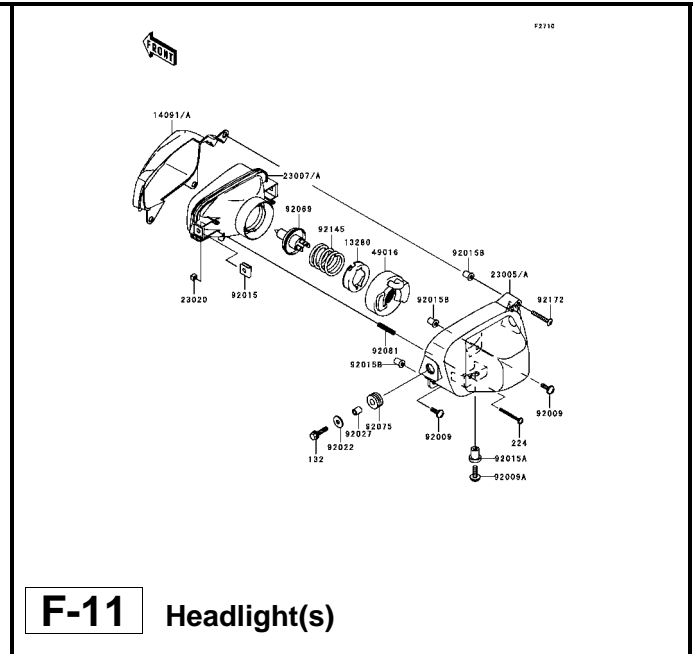
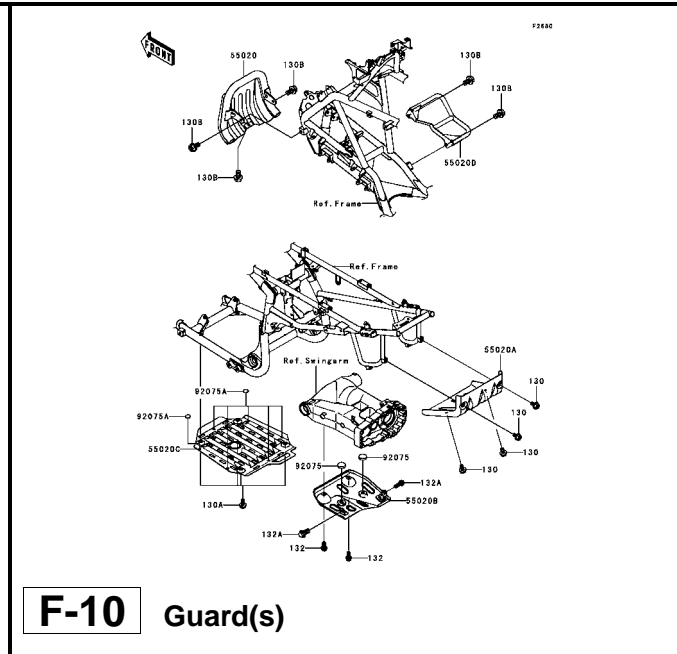
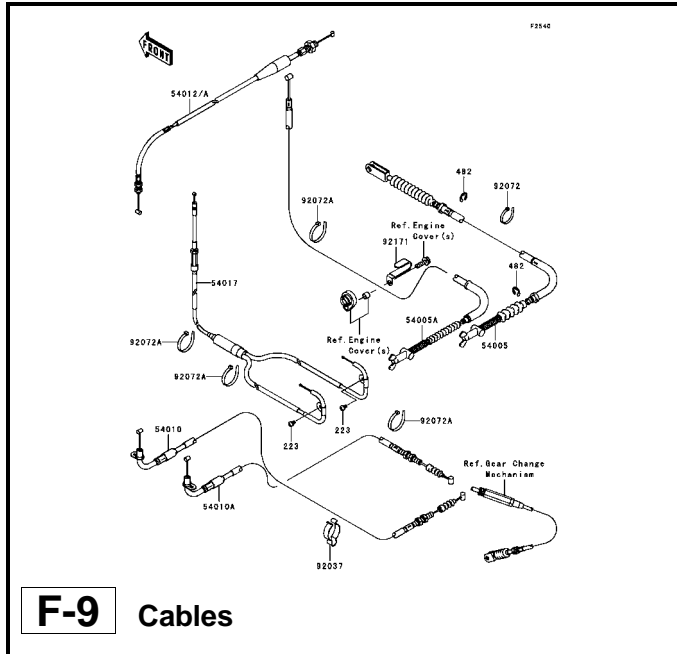

This catalog covers:

'04~'05 KSV700-A1/A2 Chassis

GRID NO.

G-1

This grid covers:

Pictorial Index

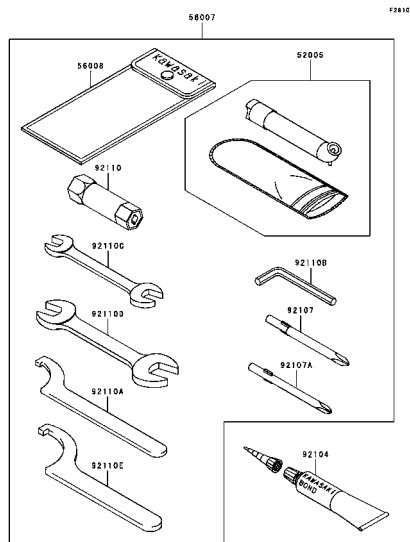

G-3 Owner's Tools

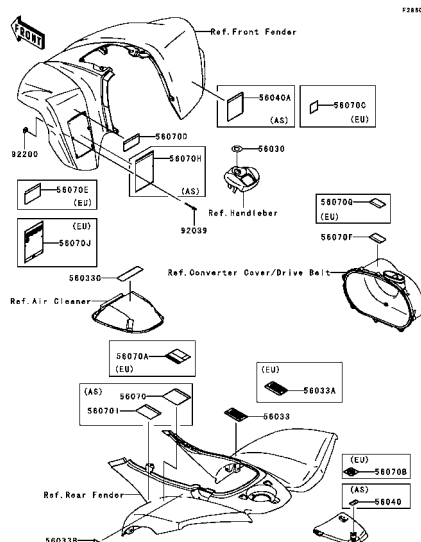

G-4 Labels(A1)

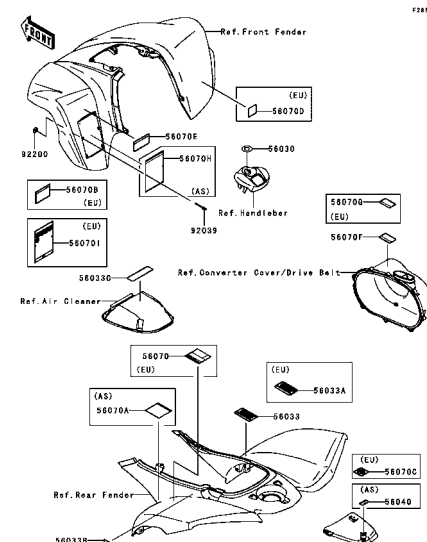

G-5 Labels(A2)

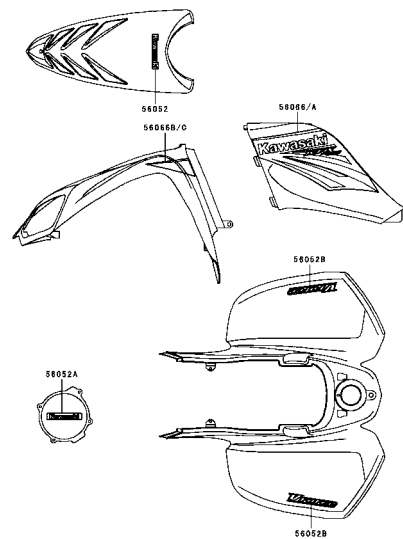

G-6 Decals(Orange)(A1)(AS)

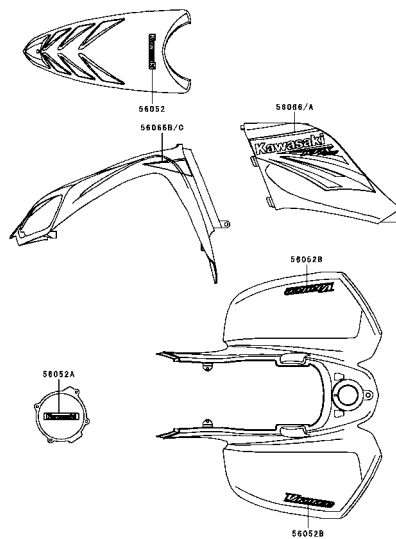

G-7 Decals(Green)(A1)

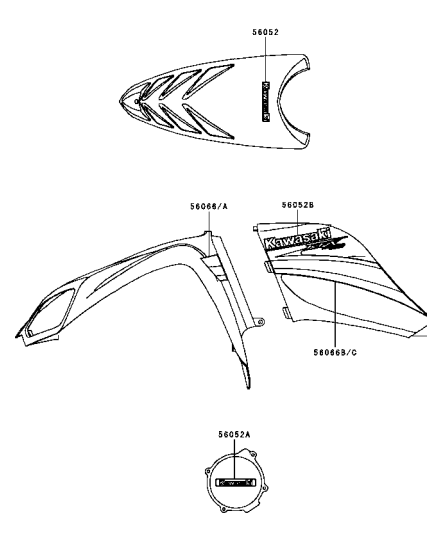

G-8 Decals(Orange)(A2)(EU)

This catalog covers:

'04~'05 KSV700-A1/A2 Chassis

GRID NO.

G-2

This grid covers:

Pictorial Index

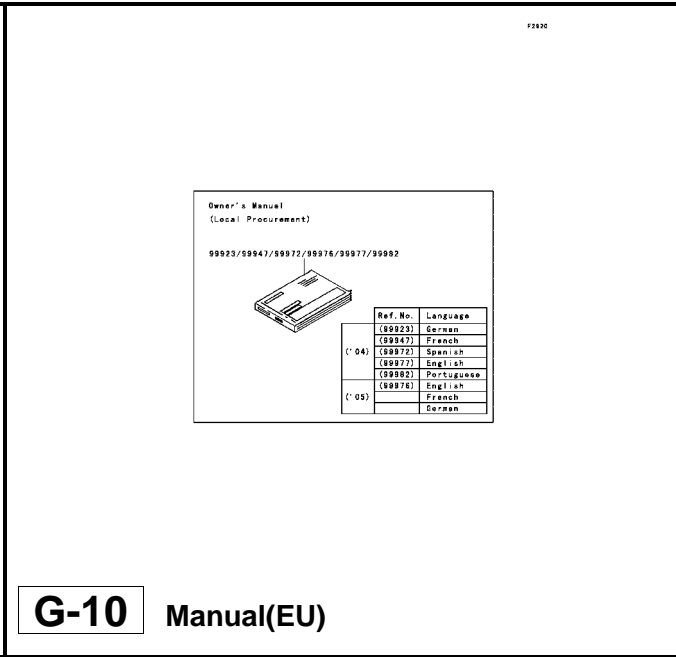
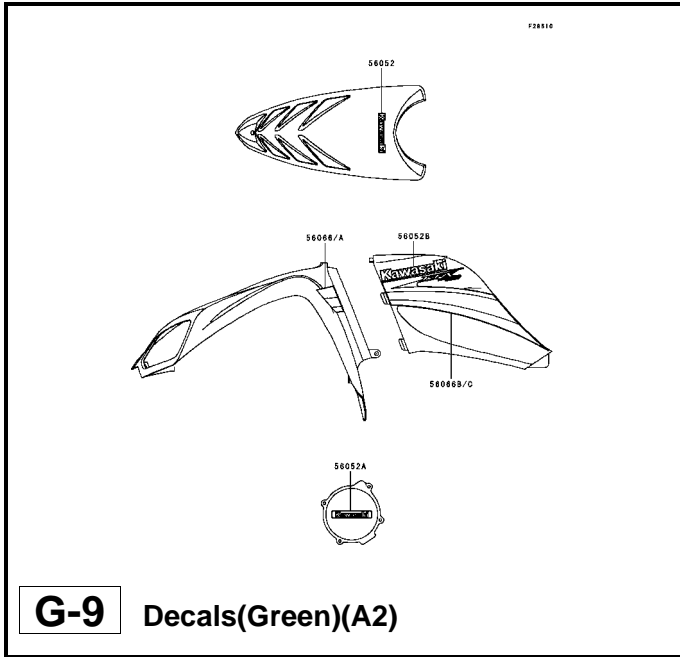

This catalog covers:

'04~'05 KSV700-A1/A2 Engine

GRID NO.

B-3

This grid covers:

Cylinder Head

E1111

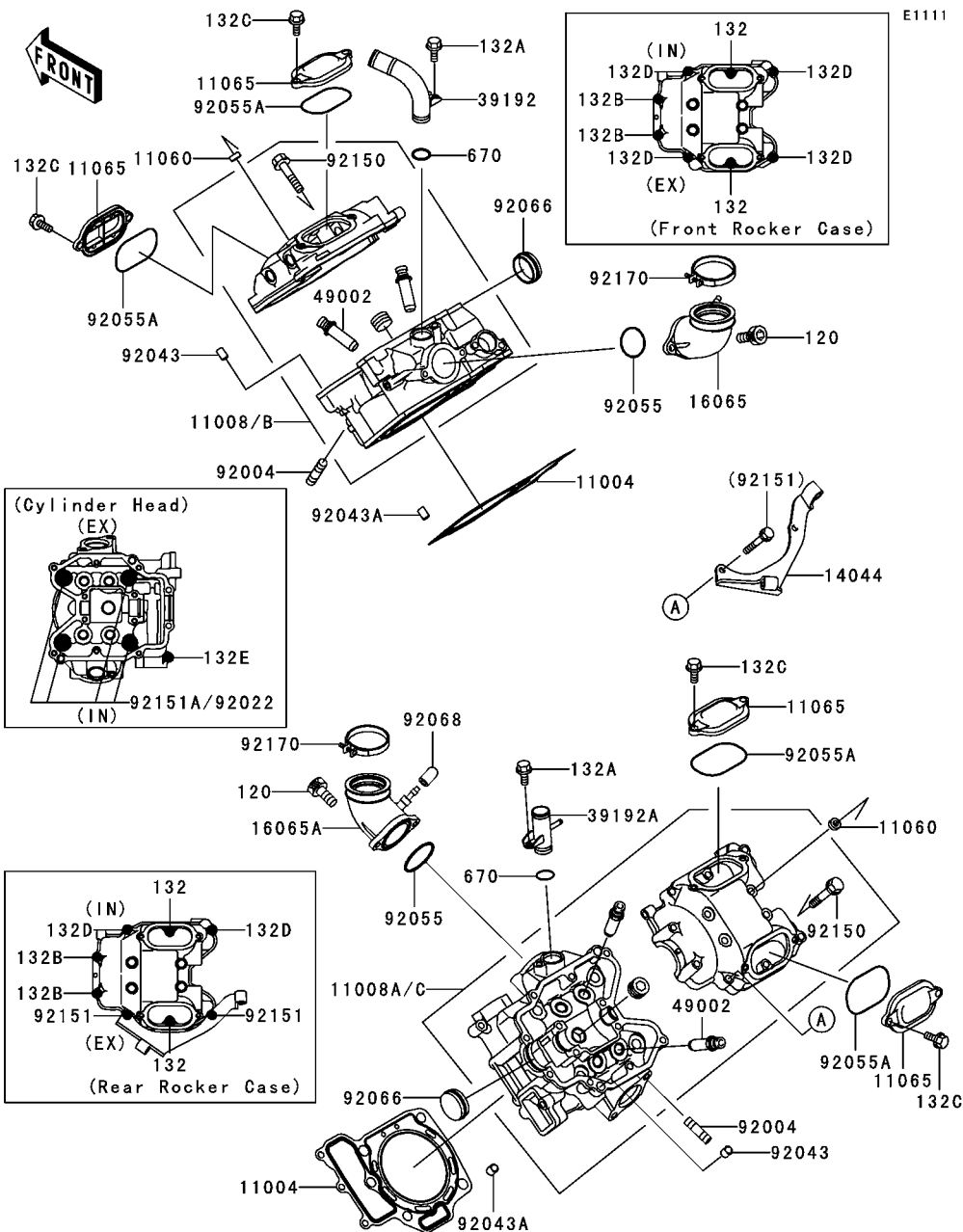

Ref. No.	Part No.	Description	Spec Code	Quantity-KSV700	
				'04	'05
				A1	A2
11004	11004-1384	GASKET-HEAD		2	2
11008	11008-0016	HEAD-COMP-CYLINDER,FR		1	
11008A	11008-0017	HEAD-COMP-CYLINDER,RR		1	
11008B	11008-0030	HEAD-COMP-CYLINDER,FR			1
11008C	11008-0031	HEAD-COMP-CYLINDER,RR			1
11060	11060-1994	GASKET,6.2X12X0.3		8	8
11065	11065-1152	CAP,ROCKER CASE		4	4
14044	14044-0001	HOLDER-CABLE		1	1
16065	16065-1370	HOLDER-CARBURETOR		1	1
16065A	16065-1371	HOLDER-CARBURETOR,RR		1	1
39192	39192-1132	PIPE-WATER		1	1
39192A	39192-1133	PIPE-WATER		1	1
49002	49002-1097	GUIDE-VALVE		AR	AR
92004	92004-1217	STUD,8X22		4	4
92022	92022-1720	WASHER,11.5X20.5X1.6		8	8
92043	92043-1263	PIN,6.2X8X14		4	4
92043A	92043-4009	PIN,10.1X12X14		4	4
92055	92055-1295	RING-O,38MM		2	2
92055A	92055-1644	RING-O,55.6X2.4		4	4
92066	92066-1289	PLUG		2	2
92068	92068-006	PLUG,12X25		1	1
92150	92150-1302	BOLT,6X55		8	8
92151	92151-1209	BOLT,FLANGED,6X34		2	2
92151A	92151-1917	BOLT		8	8
92170	92170-1722	CLAMP		2	2
120	120Z0620	BOLT-SOCKET		4	4
132	132H0625	BOLT-FLANGED-SMALL,6X25		4	4
132A	132Y0612	BOLT-FLANGED-SMALL		2	2
132B	132Y06130	BOLT-FLANGED-SMALL		4	4
132C	132Y0620	BOLT-FLANGED-SMALL		8	8
132D	132Y0630	BOLT-FLANGED-SMALL		6	6
132E	132Y0695	BOLT-FLANGED-SMALL		2	2
670	670B2016	O RING,16MM		2	2

This catalog covers:

'04~'05 KSV700-A1/A2 Engine

GRID NO.

B-4

This grid covers:

Cylinder/Piston(s)

E1120

Ref. No.	Part No.	Description	Spec Code	Quantity-KSV700			
				'04	'05		
				A1	A2		
11005	11005-1990	CYLINDER-ENGINE,FR	1	1			
11005A	11005-1992	CYLINDER-ENGINE,RR	1	1			
11060	11060-1965	GASKET,CYLINDER BASE	2	2			
13001	13001-1658	PISTON-ENGINE,STD	2	2			
13002	13002-1060	PIN-PISTON	2	2			
13008	13008-1215	RING-SET-PISTON,STD	2	2			
13025	13025-0005	RING-SET-PISTON L,O/S 0.50	AR	AR			
13029	13029-0007	PISTON-ENGINE L,O/S 0.50	AR	AR			
92022	92022-304	WASHER,6.2X11X1	2	2			
92033	92033-1207	RING-SNAP	4	4			
92043	92043-4009	PIN,10.1X12X14	4	4			
132	132Y0612	BOLT-FLANGED-SMALL	2	2			
132A	132Y0630	BOLT-FLANGED-SMALL	2	2			
132B	132Y0640	BOLT-FLANGED-SMALL	4	4			

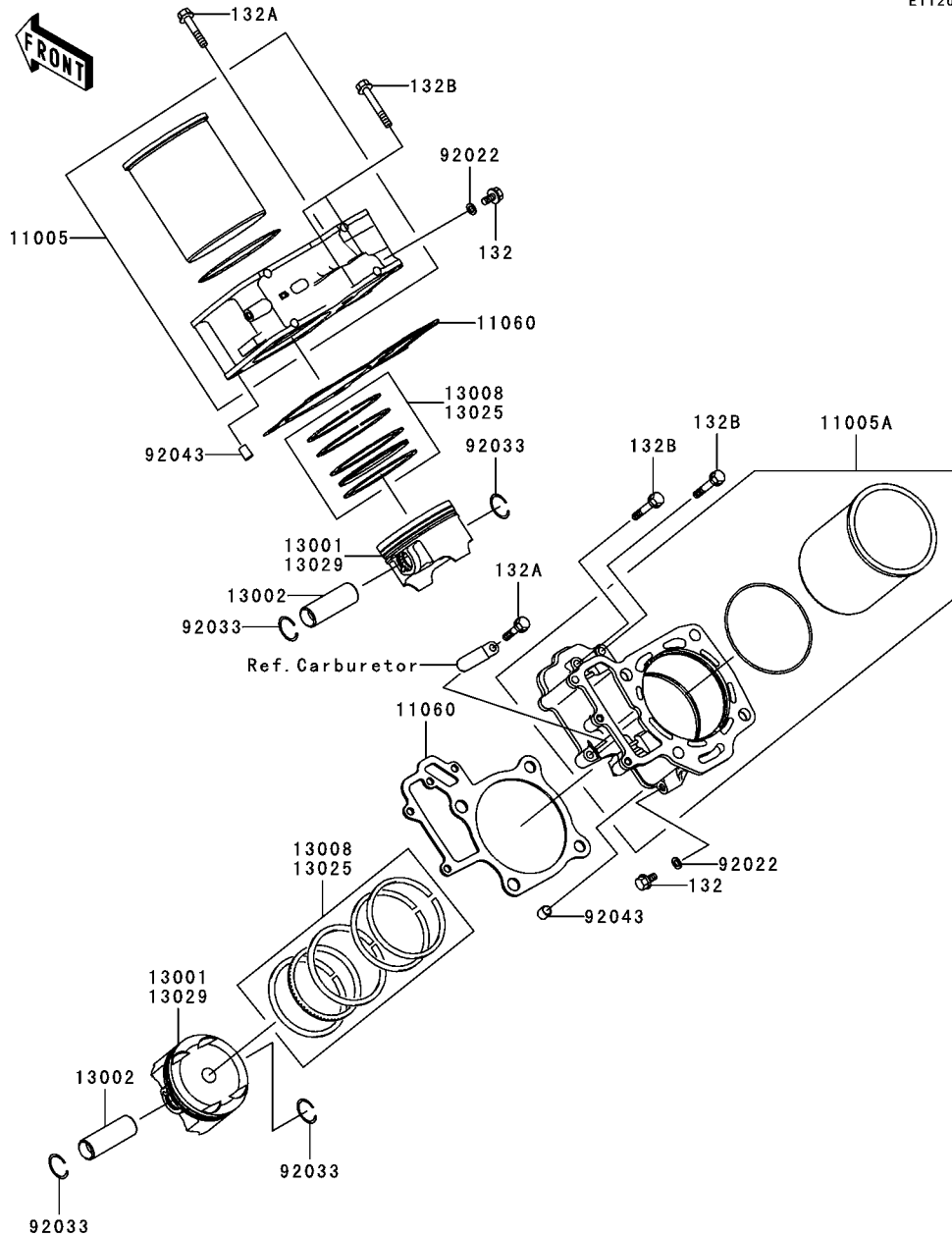

This catalog covers:

'04~'05 KSV700-A1/A2 Engine

GRID NO.

B-5

This grid covers:

Air Cleaner

E1130

Ref. No.	Part No.	Description	Spec Code	Quantity-KSV700			
				'04	'05		
				A1	A2		
11011	11011-1659	CASE-AIR FILTER,UPP		1	1		
11011A	11011-1660	CASE-AIR FILTER,LWR		1	1		
11013	11013-0001	ELEMENT-AIR FILTER		1	1		
13280	13280-1272	HOLDER		1	1		
13280A	13280-1273	HOLDER		1	1		
14073	14073-1775	DUCT,AIR FILTER JOINT		1	1		
14073A	14073-1830	DUCT,AIR FANNEL		2	2		
14073B	14073-1849	DUCT, INTAKE		1	1		
49006	49006-1292	BOOT		2	2		
92001	92001-1703	BOLT,WING,6X15		3	3		
92009	92009-1621	SCREW,6X16		4	4		
92037	92037-1460	CLAMP		2	2		
92037A	92037-147	CLAMP,TUBE		1	1		
92037B	92037-1505	CLAMP,TUBE		4	4		
92066	92066-1211	PLUG,DRAIN		1	1		
92093	92093-1522	SEAL,AIR FILTER CASE		1	1		
92093A	92093-1569	SEAL,HOLDER-HOLDER		1	1		
92093B	92093-1570	SEAL,HOLDER-LOWER		1	1		
92151	92151-1305	BOLT,5X12		8	8		
92153	92153-1052	BOLT		2	2		
92160	92160-1594	DAMPER		2	2		
92170	92170-1514	CLAMP		1	1		
92170A	92170-1764	CLAMP		2	2		
92171	92171-1394	CLAMP,AIR FILTER CASE		4	4		
92171A	92171-1522	CLAMP,AIR VENT		1	1		
92191	92191-1494	TUBE,7X11X210		1	1		
92191A	92191-1531	TUBE,7X11X470		2	2		
132	132Y0612	BOLT-FLANGED-SMALL		1	1		

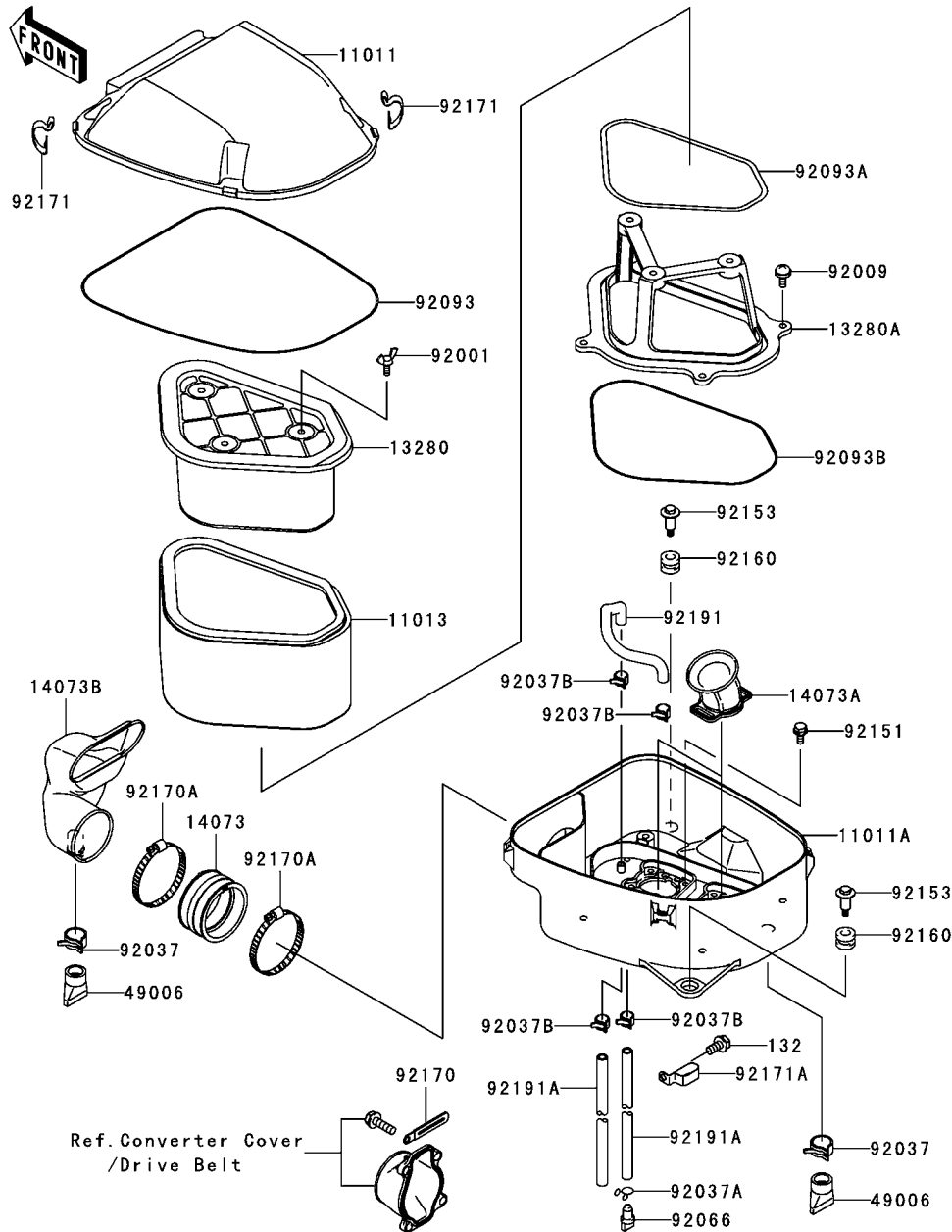

This catalog covers:

'04~'05 KSV700-A1/A2 Engine

GRID NO.

B-6

This grid covers:

Muffler(s)

E1140

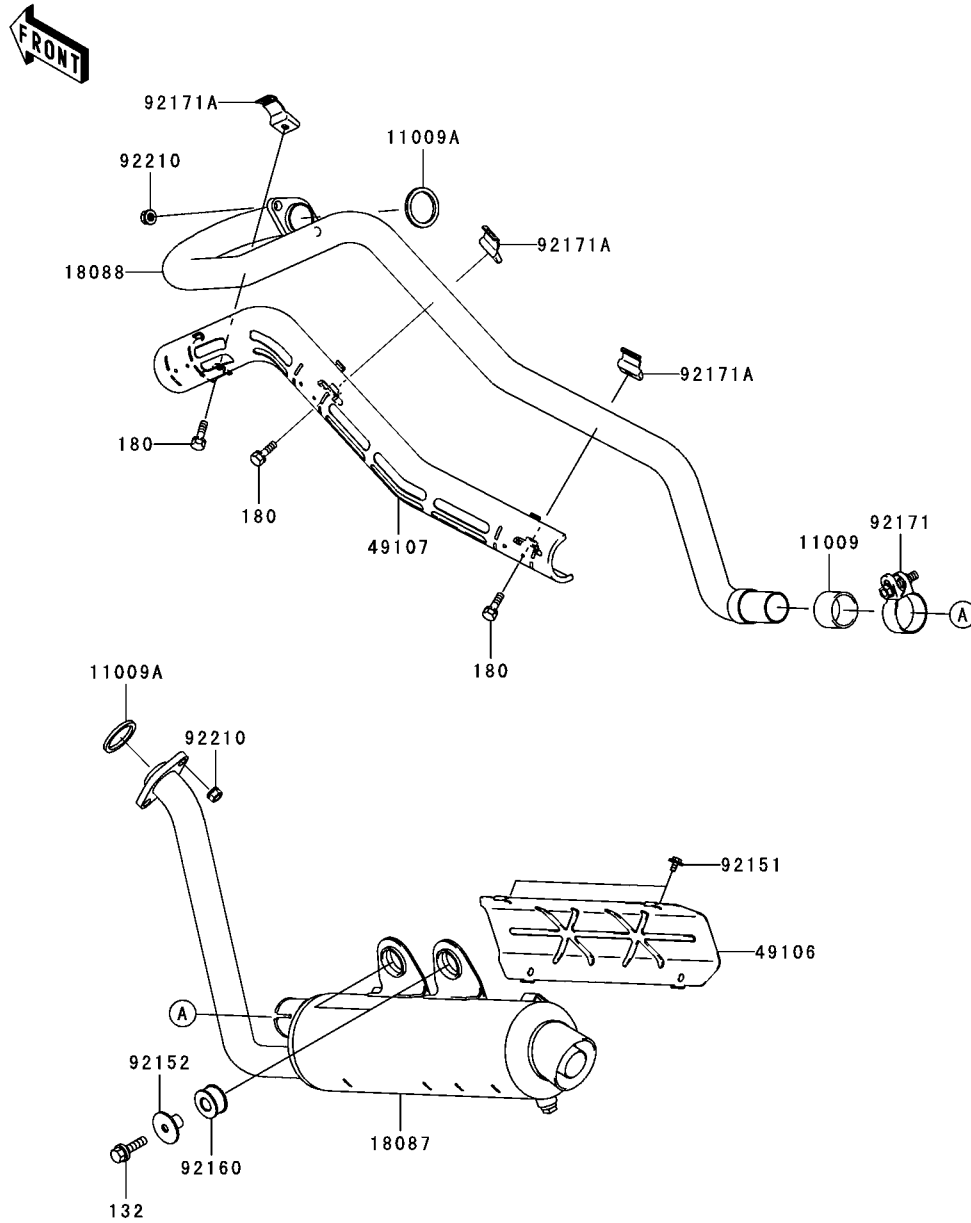

Ref. No.	Part No.	Description	Spec Code	Quantity-KSV700			
				'04	'05		
				A1	A2		
11009	11009-1865	GASKET,MUFFLER CONNECTING	1	1			
11009A	11009-1894	GASKET,EXHAUST HOLDER	2	2			
18087	18087-0006	MUFFLER	1	1			
18088	18088-1222	PIPE-EXHAUST	1	1			
49106	49106-1293	COVER-MUFFLER	1	1			
49107	49107-1226	COVER-EXHAUST PIPE	1	1			
92151	92151-1944	BOLT,6X12	4	4			
92152	92152-1152	COLLAR,MUFFLER	2	2			
92160	92160-1990	DAMPER,MUFFLER	2	2			
92171	92171-1330	CLAMP	1	1			
92171A	92171-1357	CLAMP	3	3			
92210	92210-1242	NUT,RH,THREAD 8MM	4	4			
132	132Y0830	BOLT-FLANGED-SMALL	2	2			
180	180Y0620	BOLT-UPSET-WS	3	3			

This catalog covers:

'04~'05 KSV700-A1/A2 Engine

GRID NO.

B-7

This grid covers:

Valve(s)(A1)

E1210

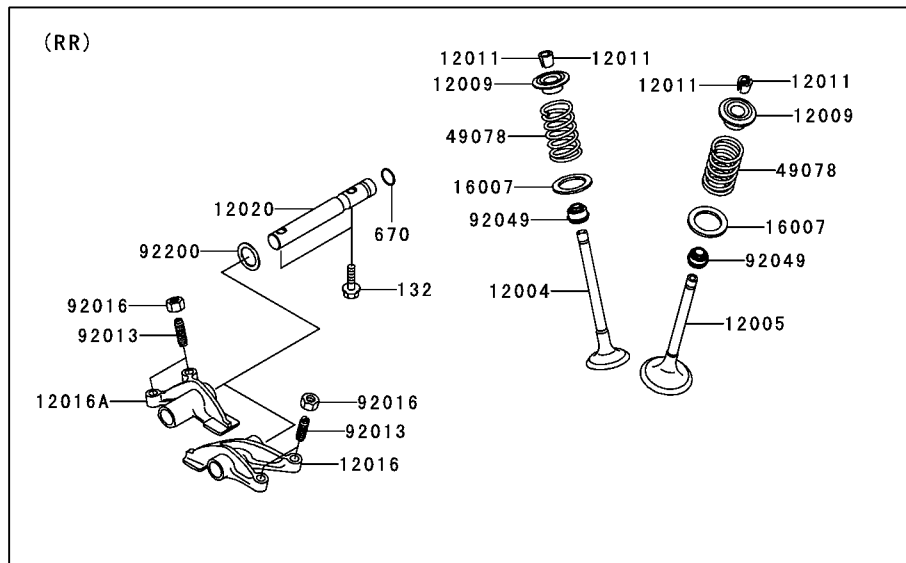
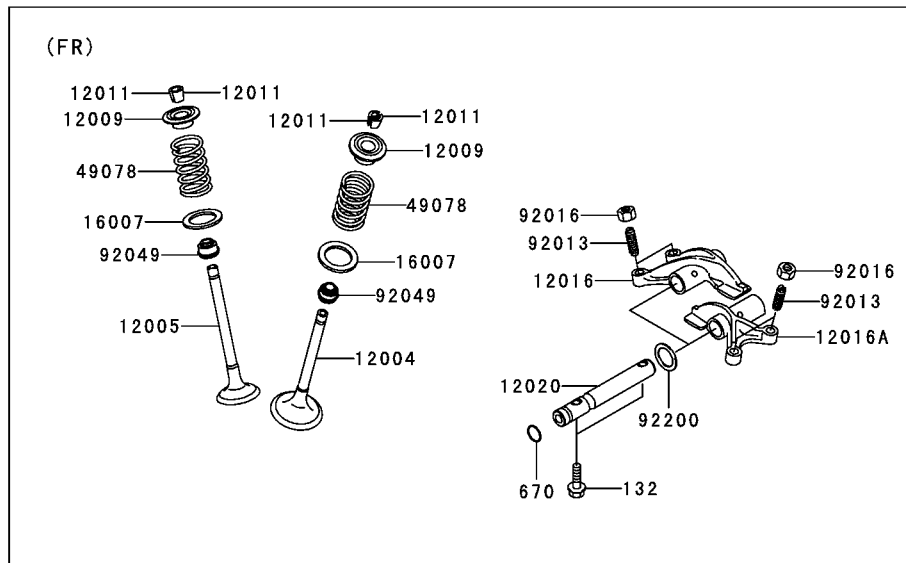

Ref. No.	Part No.	Description	Spec Code	Quantity-KSV700			
				'04	'05		
				A1	A2		
12004	12004-1146	VALVE-INTAKE		4			
12005	12005-1349	VALVE-EXHAUST		4			
12009	12009-1056	RETAINER-VALVE SPRING		8			
12011	12011-1051	COLLET		16			
12016	12016-1128	ARM-ROCKER,EXHAUST		2			
12016A	12016-1129	ARM-ROCKER,INTAKE		2			
12020	12020-1083	SHAFT-ROCKER		4			
16007	16007-1178	SEAT-SPRING,17.5X23.8X0.5		8			
49078	49078-1073	SPRING-ENGINE VALVE		8			
92013	92013-009	SCREW,6MM		8			
92016	92016-061	NUT,6MM		8			
92049	92049-1218	SEAL-OIL,VSB58.558		8			
92200	92200-1508	WASHER,ROCKER ARM		4			
132	132Y0612	BOLT-FLANGED-SMALL		8			
670	670D1509	O RING,9MM		4			

This catalog covers:

'04~'05 KSV700-A1/A2 Engine

GRID NO.

B-8

This grid covers:

Valve(s)(A2)

E1210A

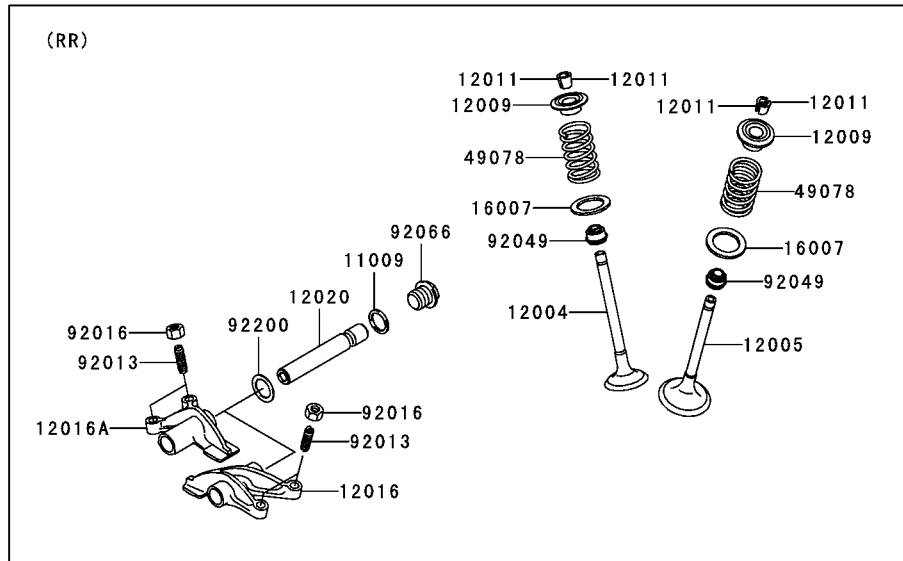
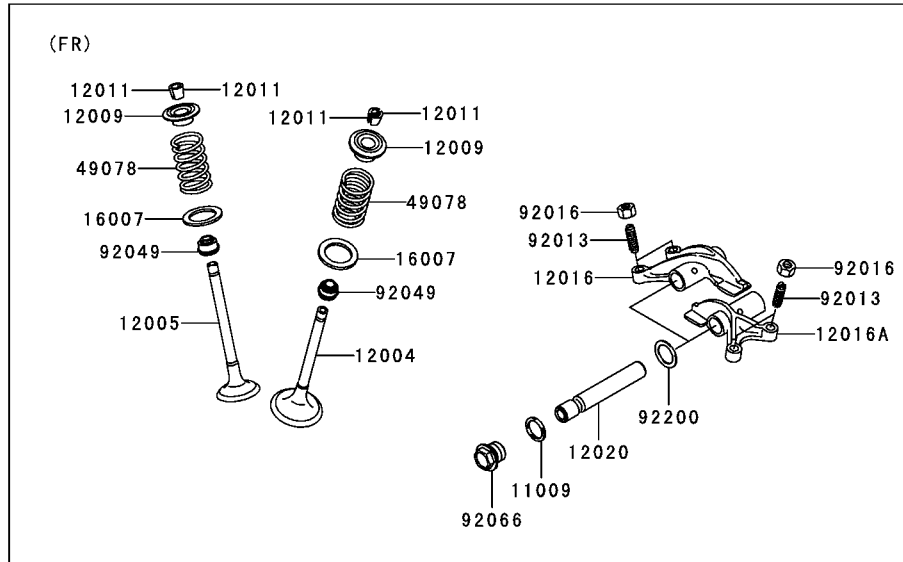

Ref. No.	Part No.	Description	Spec Code	Quantity-KSV700			
				'04	'05		
				A1	A2		
11009	11009-1430	GASKET,14X18X1.5			4		
12004	12004-1146	VALVE-INTAKE			4		
12005	12005-1349	VALVE-EXHAUST			4		
12009	12009-1056	RETAINER-VALVE SPRING			8		
12011	12011-1051	COLLET			16		
12016	12016-1128	ARM-ROCKER,EXHAUST			2		
12016A	12016-1129	ARM-ROCKER,INTAKE			2		
12020	12020-0004	SHAFT-ROCKER			4		
16007	16007-1178	SEAT-SPRING,17.5X23.8X0.5			8		
49078	49078-0014	SPRING-ENGINE VALVE			8		
92013	92013-009	SCREW,6MM			8		
92016	92016-061	NUT,6MM			8		
92049	92049-1218	SEAL-OIL,VSB58.558			8		
92066	92066-2196	PLUG,DRAIN			4		
92200	92200-1508	WASHER,ROCKER ARM			4		

This catalog covers:

'04~'05 KSV700-A1/A2 Engine

GRID NO.

B-9

This grid covers:

Camshaft(s)/Tensioner(A1)

E1230

Ref. No.	Part No.	Description	Spec Code	Quantity-KSV700			
				'04	'05		
				A1	A2		

11060	11060-1966	GASKET					1
12046	12046-1203	SPROCKET,CAMSHAFT,34T					2
12046A	12046-1207	SPROCKET,2ND SHAFT,21T&17T					1
12048	12048-1176	TENSIONER-ASSY,CAM					2
12048A	12048-1177	TENSIONER-ASSY,SECONDARY					1
12053	12053-1441	GUIDE-CHAIN,CAMSHAFT,TENSION					2
12053A	12053-1442	GUIDE-CHAIN,CAMSHAFT,SLACK					2
12053B	12053-1443	GUIDE-CHAIN,TENSION					1
12053C	12053-1444	GUIDE-CHAIN,SLACK					1
13042	13042-1141	WEIGHT,DECOMP					4
13107	13107-1443	SHAFT,CHAIN GUIDE,FR					1
13107A	13107-1444	SHAFT,CHAIN GUIDE,RR					1
13107B	13107-1514	SHAFT,SECONDARY					1
14014	14014-1148	PLATE-POSITION,DRIVE					1
49118	49118-0001	CAMSHAFT-COMP,FR					1
49118A	49118-0002	CAMSHAFT-COMP,RR					1
92015	92015-1433	NUT,FLANGED,12MM					1
92033	92033-1039	RING-SNAP,8MM					1
92055	92055-086	RING-O					2
92057	92057-1536	CHAIN,SECONDARY SHAFT					1
92057A	92057-1537	CHAIN,CAM SHAFT					2
92145	92145-1303	SPRING,DECOMP					2
92153	92153-1200	BOLT					2
120	120P0610	BOLT-SOCKET,6X10					4
120A	120S0614	BOLT-SOCKET,6X14,BLACK					2
132	132Y0630	BOLT-FLANGED-SMALL					6
410	410B0800	WASHER-PLAIN-SMALL,8MM					1
482	482J5000	CIRCLIP-TYPE-E					4

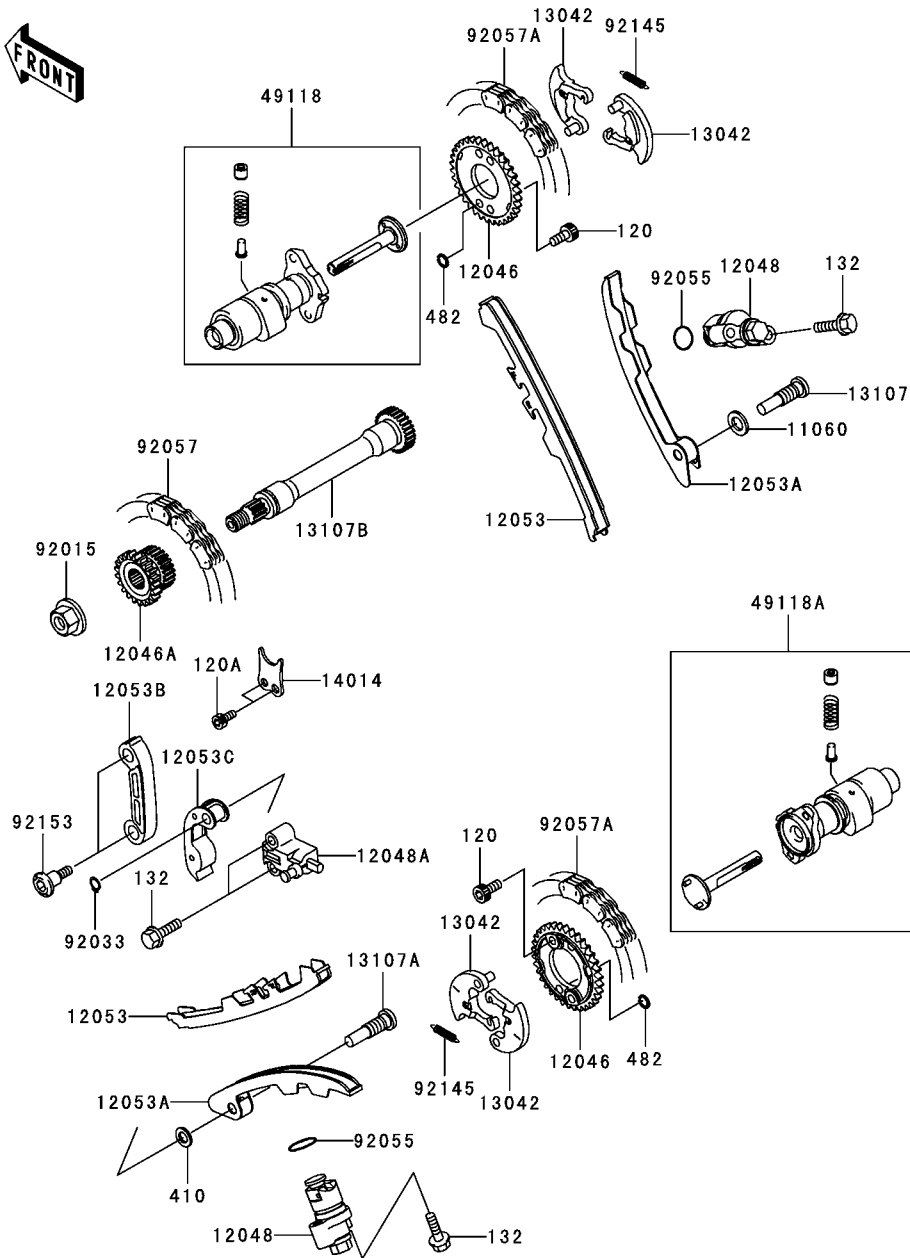

This catalog covers:

'04~'05 KSV700-A1/A2 Engine

GRID NO.

B-10

This grid covers:

Camshaft(s)/Tensioner(A2)

E1230A

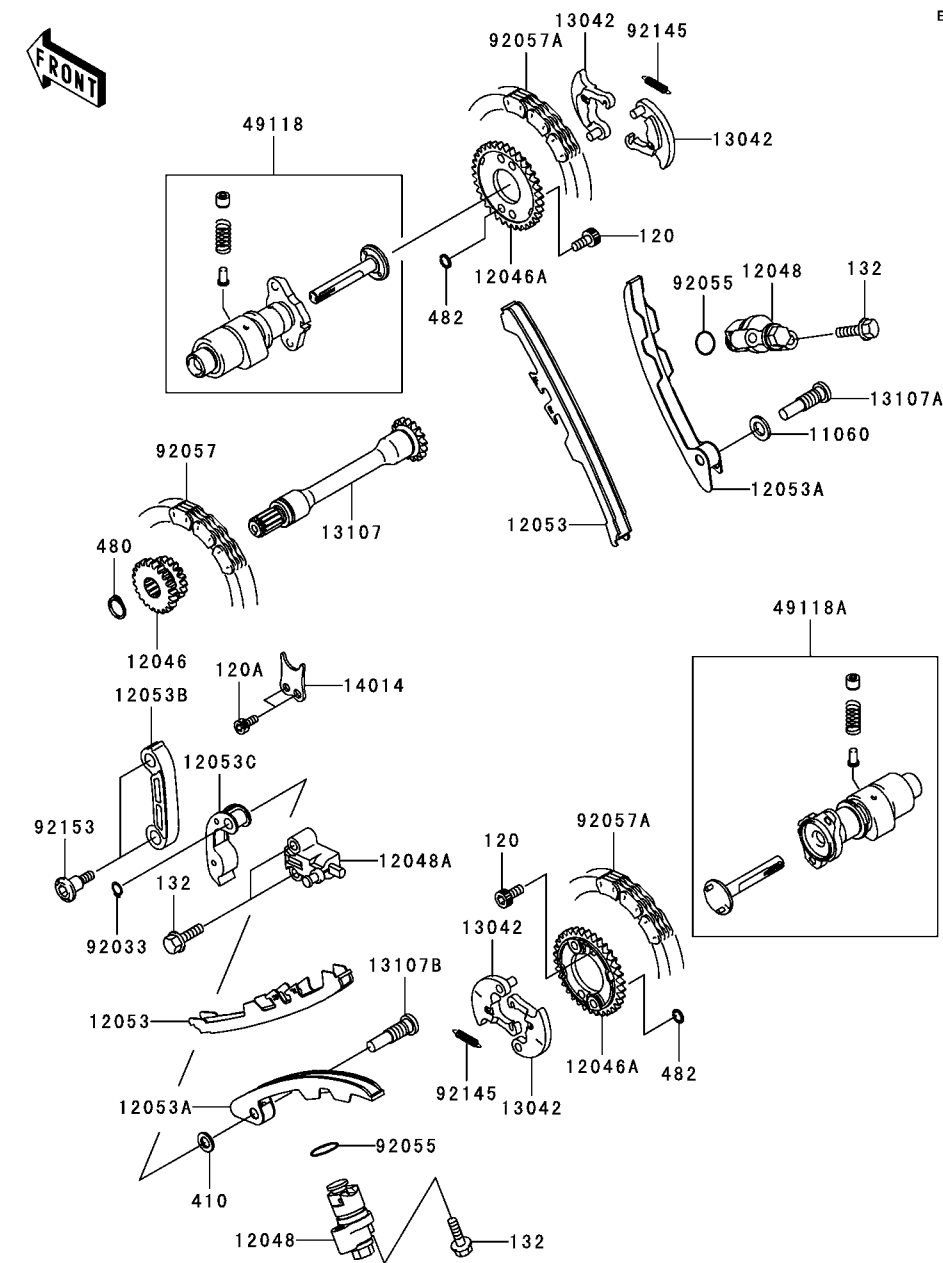

Ref. No.	Part No.	Description	Spec Code	Quantity-KSV700			
				'04	'05		
				A1	A2		
11060	11060-1966	GASKET				1	
12046	12046-0021	SPROCKET,21T&17T				1	
12046A	12046-1203	SPROCKET,CAMSHAFT,34T				2	
12048	12048-1176	TENSIONER-ASSY,CAM				2	
12048A	12048-1177	TENSIONER-ASSY,SECONDARY				1	
12053	12053-1441	GUIDE-CHAIN,CAMSHAFT,TENSION				2	
12053A	12053-1442	GUIDE-CHAIN,CAMSHAFT,SLACK				2	
12053B	12053-1443	GUIDE-CHAIN,TENSION				1	
12053C	12053-1444	GUIDE-CHAIN,SLACK				1	
13042	13042-1141	WEIGHT,DECOMP				4	
13107	13107-0029	SHAFT				1	
13107A	13107-1443	SHAFT,CHAIN GUIDE,FR				1	
13107B	13107-1444	SHAFT,CHAIN GUIDE,RR				1	
14014	14014-1148	PLATE-POSITION,DRIVE				1	
49118	49118-0001	CAMSHAFT-COMP,FR				1	
49118A	49118-0002	CAMSHAFT-COMP,RR				1	
92033	92033-1039	RING-SNAP,8MM				1	
92055	92055-086	RING-O				2	
92057	92057-1536	CHAIN,SECONDARY SHAFT				1	
92057A	92057-1537	CHAIN,CAM SHAFT				2	
92145	92145-1303	SPRING,DECOMP				2	
92153	92153-1200	BOLT				2	
120	120P0610	BOLT-SOCKET,6X10				4	
120A	120S0614	BOLT-SOCKET,6X14,BLACK				2	
132	132Y0630	BOLT-FLANGED-SMALL				6	
410	410B0800	WASHER-PLAIN-SMALL,8MM				1	
480	480J1400	CIRCLIP-TYPE-C,14MM				1	
482	482J5000	CIRCLIP-TYPE-E				4	

This catalog covers:

'04~'05 KSV700-A1/A2 Engine

GRID NO.

B-11

This grid covers:

Crankshaft

E1321

Ref. No.	Part No.	Description	Spec Code	Quantity-KSV700			
				'04	'05		
				A1	A2		
13031	13031-0030	CRANKSHAFT-COMP	1	1			
13251	13251-1143	ROD-ASSY-CONNECTING	2	2			
92001	92001-1980	BOLT,CONNECTING ROD	4	4			
92015	92015-1311	NUT,FLANGED,8MM	4	4			
92028	92028-1961	BUSHING,CONNECTING ROD,GREEN	AR	AR			
92028A	92028-1962	BUSHING,CONNECTING ROD,YELLOW	4	4			
92028B	92028-1963	BUSHING,CONNECTING ROD,BROWNE	AR	AR			

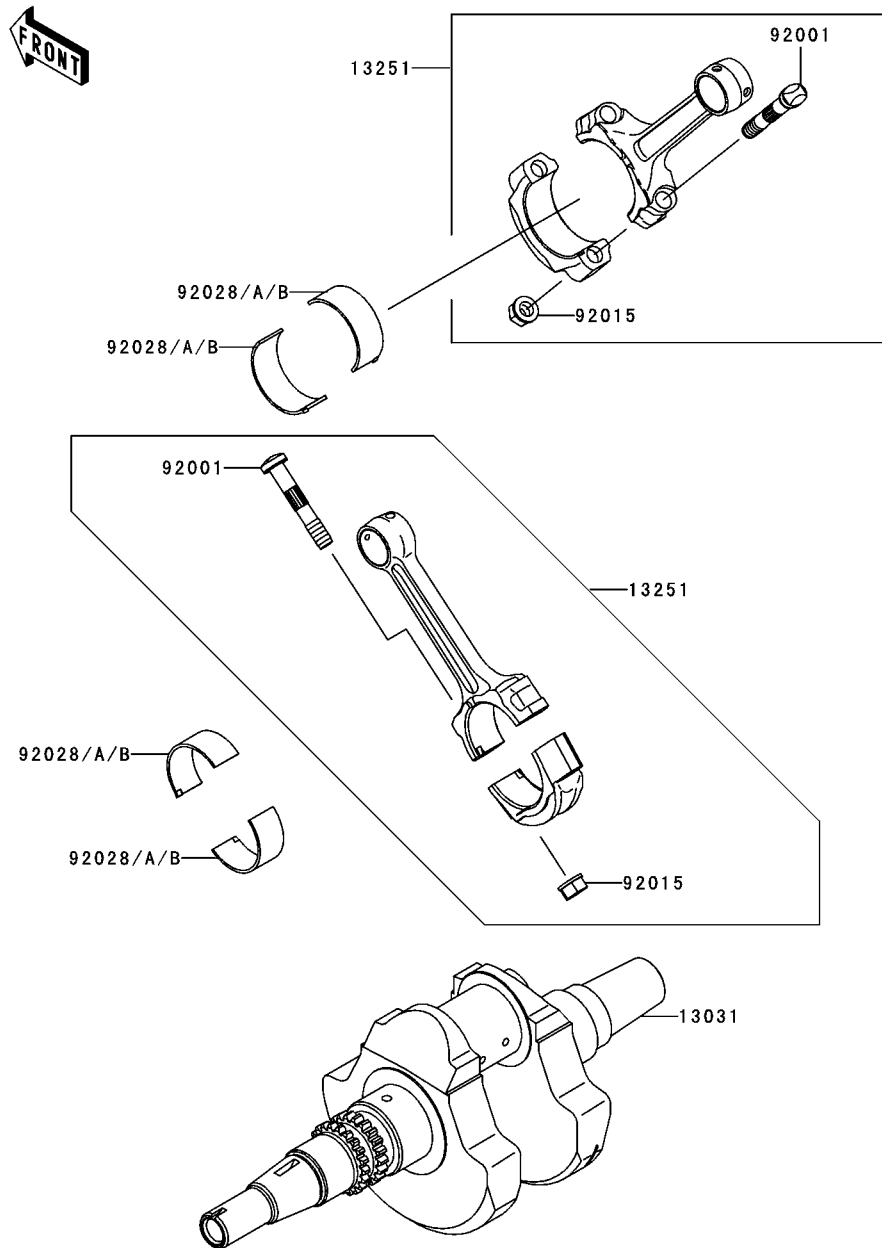

This catalog covers:

'04~'05 KSV700-A1/A2 Engine

GRID NO.

B-12

This grid covers:

Transmission

E1361

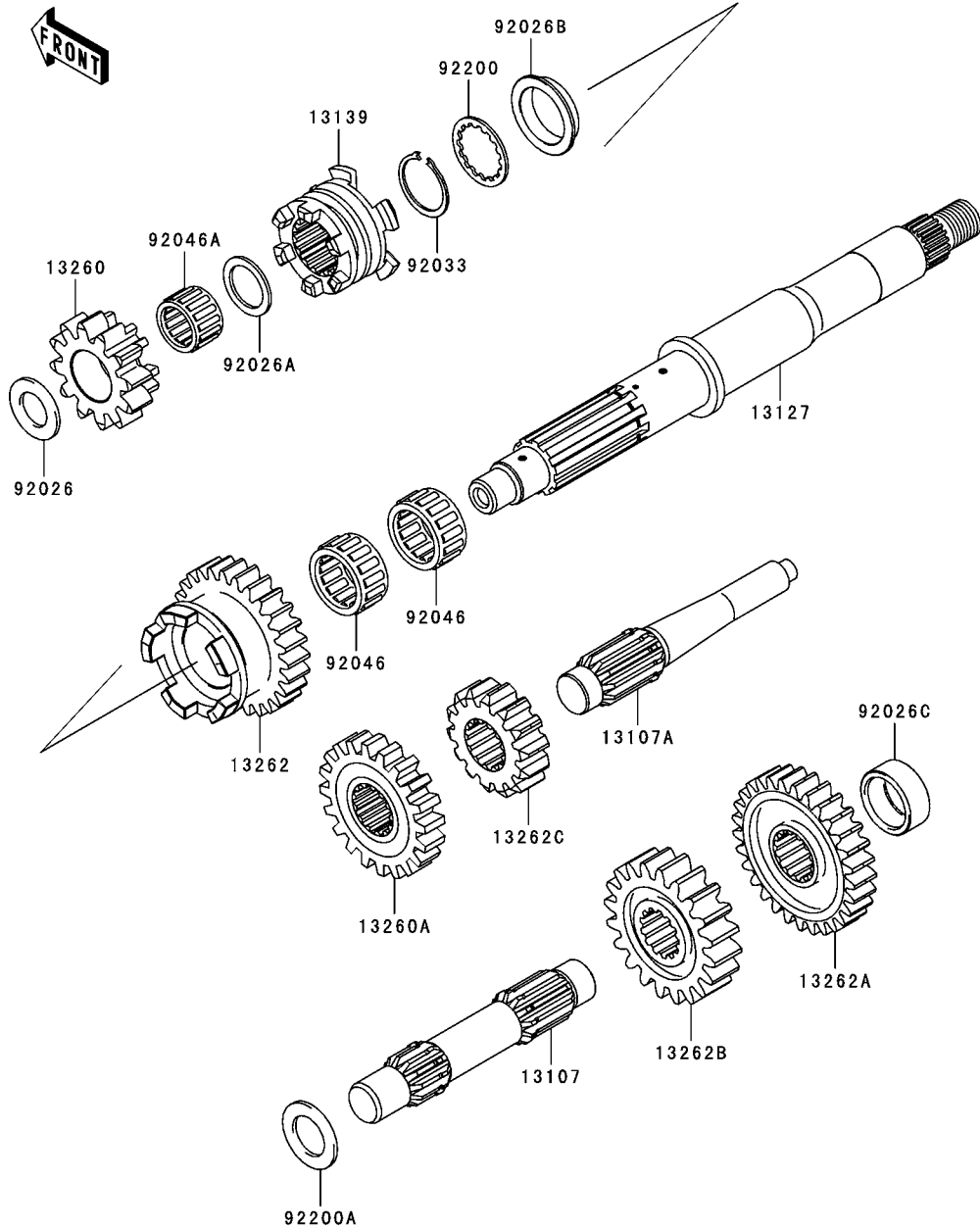

Ref. No.	Part No.	Description	Spec Code	Quantity-KSV700			
				'04	'05		
				A1	A2		
13107	13107-1436	SHAFT,OUTPUT	1	1			
13107A	13107-1437	SHAFT,REVERSE, IDLE	1	1			
13127	13127-1282	SHAFT-TRANSMISSION INPUT	1	1			
13139	13139-1096	SHIFTER	1	1			
13260	13260-1868	GEAR,INPUT REVERSE,12T	1	1			
13260A	13260-1873	GEAR,DRIVEN REVERSE,16T	1	1			
13262	13262-0002	GEAR,INPUT HIGH,27T	1	1			
13262A	13262-0015	GEAR,DRIVEN HIGH,29T	1	1			
13262B	13262-1052	GEAR,OUTPUT DRIVE,20T	1	1			
13262C	13262-1053	GEAR,OUTPUT REVERSE,14T	1	1			
92026	92026-1415	SPACER,17.3X30X2.0	1	1			
92026A	92026-1568	SPACER,21.2X29X1.6	1	1			
92026B	92026-1629	SPACER,28X39X8	1	1			
92026C	92026-1630	SPACER,25X32X13	1	1			
92033	92033-1037	RING-SNAP,T=1.2	1	1			
92046	92046-1278	BEARING-NEEDLE,LOW GEAR	2	2			
92046A	92046-1279	BEARING-NEEDLE,REVERSE GEAR	1	1			
92200	92200-1240	WASHER,T=1.5	1	1			
92200A	92200-1351	WASHER,20.3X33X2.0	1	1			

This catalog covers:

'04~'05 KSV700-A1/A2 Engine

GRID NO.

B-14

This grid covers:

Drive Converter

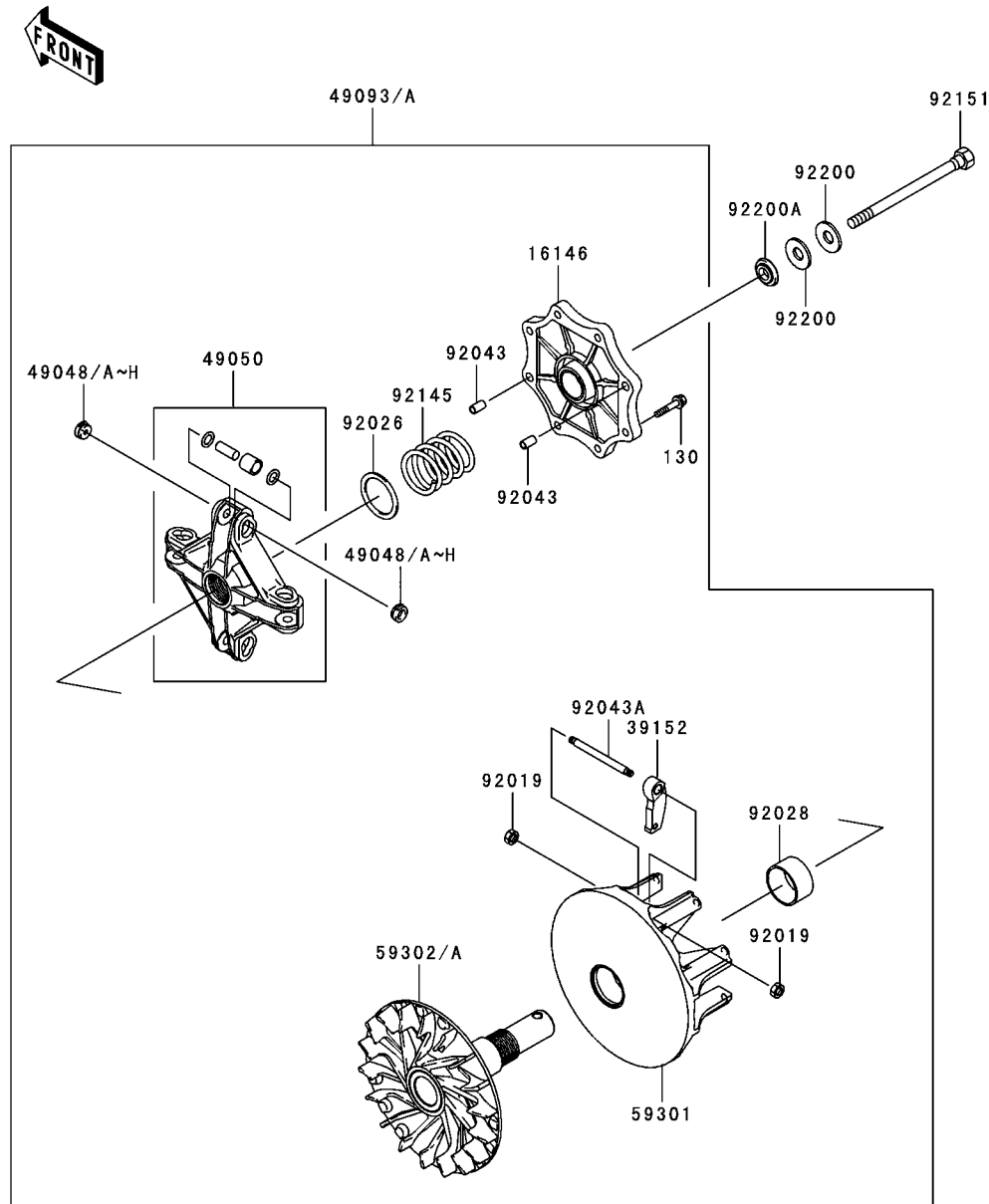

E1391

Ref. No.	Part No.	Description	Spec Code	Quantity-KSV700			
				'04	'05		
				A1	A2		
16146	16146-1231	COVER-ASSY	1	1			
39152	39152-1088	WEIGHT-RAMP	4	4			
49048	49048-1087	SHOE,T=7.2	AR	AR			
49048A	49048-1088	SHOE,T=7.3	AR	AR			
49048B	49048-1089	SHOE,T=7.4	AR	AR			
49048C	49048-1090	SHOE,T=7.5	AR	AR			
49048D	49048-1091	SHOE,T=7.6	AR	AR			
49048E	49048-1092	SHOE,T=7.7	AR	AR			
49048F	49048-1093	SHOE,T=7.8	AR	AR			
49048G	49048-1094	SHOE,T=7.9	AR	AR			
49048H	49048-1095	SHOE,T=8.0	AR	AR			
49050	49050-1081	SPIDER	1	1			
49093	49093-0010	CONVERTER-ASSY-DRIVE			1		
49093A	49093-1076	CONVERTER-ASSY-DRIVE	1				
59301	59301-1070	SHEAVE-MOVABLE	1	1			
59302	59302-0003	SHEAVE-COMP			1		
59302A	59302-1106	SHEAVE-COMP	1				
92019	92019-008	NUT,LOCK,6MM	8	8			
92026	92026-1603	SPACER,39X49.5X1.0	1	1			
92028	92028-1975	BUSHING	1	1			
92043	92043-1263	PIN,6.2X8X14	2	2			
92043A	92043-1688	PIN	4	4			
92145	92145-0021	SPRING	1	1			
92151	92151-1393	BOLT	1	1			
92200	92200-1504	WASHER,SPRING	2	2			
92200A	92200-1634	WASHER	1	1			
130	130T0630	BOLT-FLANGED	8	8			

This catalog covers:

'04~'05 KSV700-A1/A2 Engine

GRID NO.

C-3

This grid covers:

Driven Converter

E1392

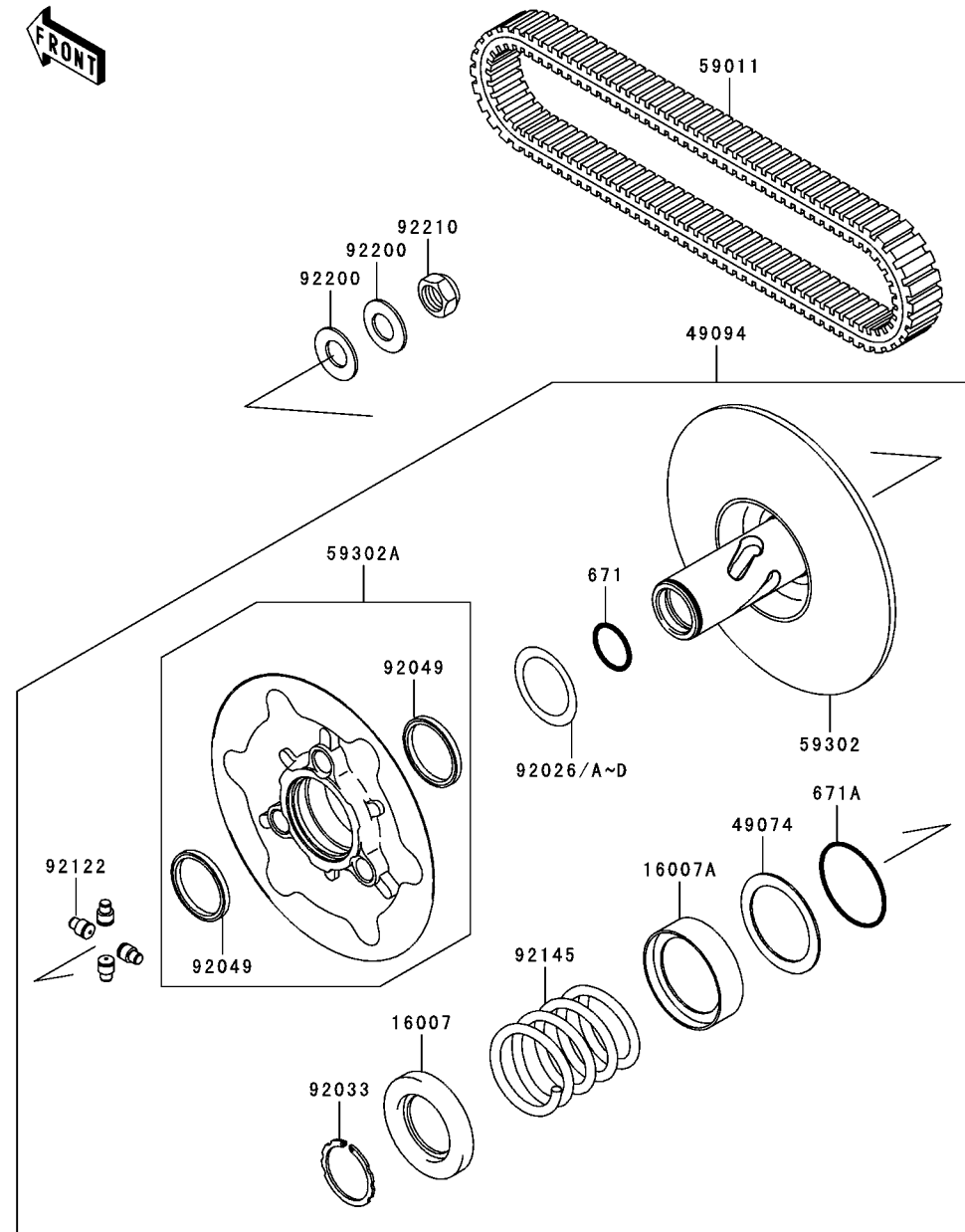

Ref. No.	Part No.	Description	Spec Code	Quantity-KSV700			
				'04	'05		
				A1	A2		
16007	16007-1203	SEAT-SPRING	1	1			
16007A	16007-1221	SEAT-SPRING,SHEAVE MOVABLE	1	1			
49074	49074-1055	PLATE-THRUST	1	1			
49094	49094-0005	CONVERTER-ASSY-DRIVEN	1	1			
59011	59011-0003	BELT	1	1			
59302	59302-0001	SHEAVE-COMP,FIXED	1	1			
59302A	59302-0002	SHEAVE-COMP,MOVABLE	1	1			
92026	92026-0034	SPACER,T=0.3	AR	AR			
92026A	92026-1565	SPACER,T=1.00	1	1			
92026B	92026-1569	SPACER,T=0.60	AR	AR			
92026C	92026-1570	SPACER,T=1.40	AR	AR			
92026D	92026-1617	SPACER,T=0.8	AR	AR			
92033	92033-1317	RING-SNAP	1	1			
92049	92049-1528	SEAL-OIL	2	2			
92122	92122-1209	ROLLER	4	4			
92145	92145-1462	SPRING,YELLOW	1	1			
92200	92200-1505	WASHER	2	2			
92210	92210-1367	NUT,18MM	1	1			
671	671D2530	O RING	1	1			
671A	671D2550	O RING	1	1			

This catalog covers:

'04~'05 KSV700-A1/A2 Engine

GRID NO.

C-4

This grid covers:

Converter Cover/Drive Belt

E1393

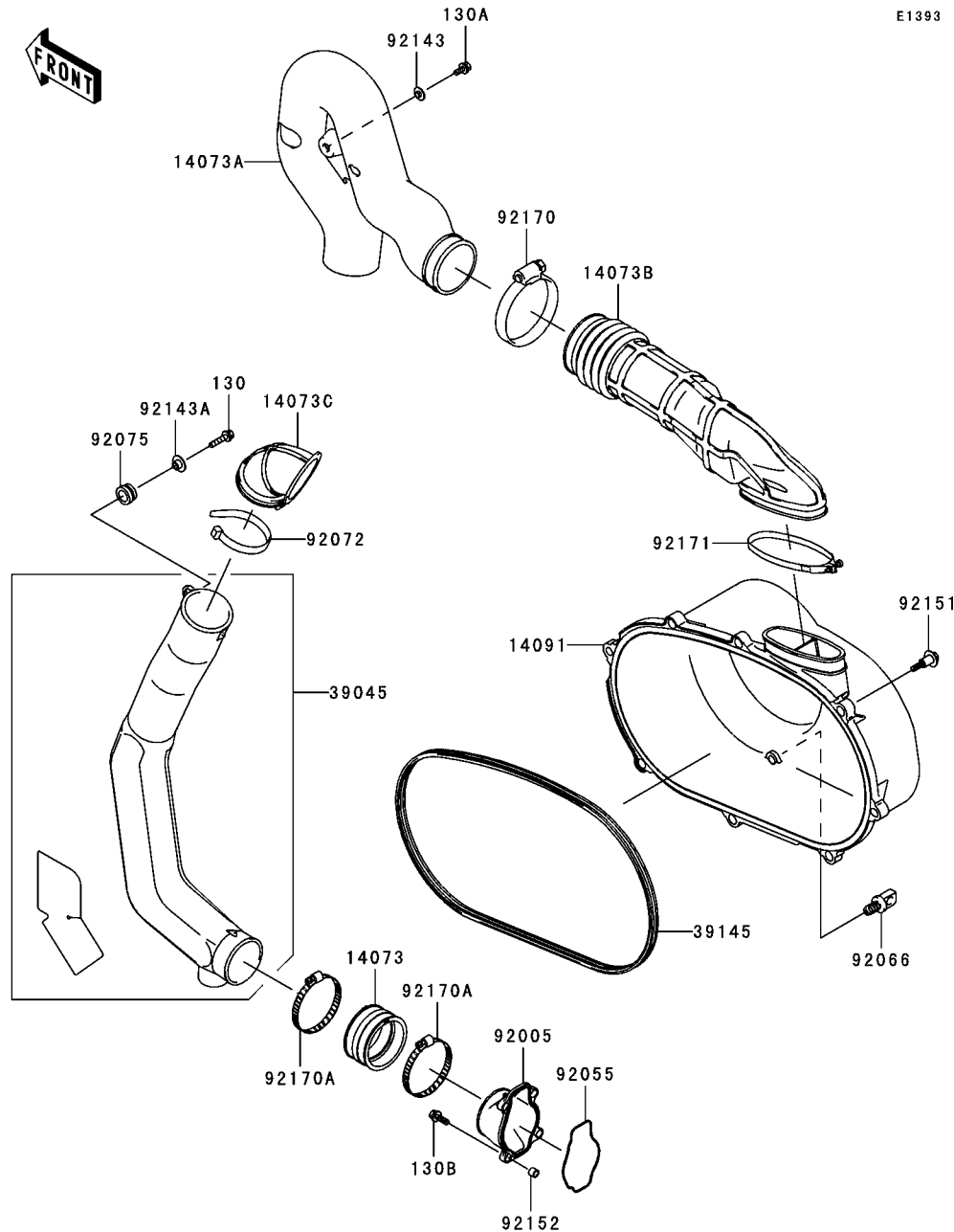

Ref. No.	Part No.	Description	Spec Code	Quantity-KSV700			
				'04	'05		
				A1	A2		
14073	14073-1775	DUCT,AIR FILTER JOINT	1	1			
14073A	14073-1850	DUCT,EXHAUST	1	1			
14073B	14073-1851	DUCT,EXHAUST JOINT	1	1			
14073C	14073-1853	DUCT,SNORKEL TOP	1	1			
14091	14091-1535	COVER,BELT CONVERTER	1	1			
39045	39045-1072	DUCT-ASSY,SNORKEL	1	1			
39145	39145-1135	TRIM-SEAL	1	1			
92005	92005-1387	FITTING	1	1			
92055	92055-1630	RING-O	1	1			
92066	92066-1580	PLUG,DRAIN,11X19	1	1			
92072	92072-1197	BAND,L=365	1	1			
92075	92075-1123	DAMPER,RUBBER	1	1			
92143	92143-1087	COLLAR	1	1			
92143A	92143-1353	COLLAR	1	1			
92151	92151-1686	BOLT	8	8			
92152	92152-1332	COLLAR	4	4			
92170	92170-1763	CLAMP	1	1			
92170A	92170-1764	CLAMP	2	2			
92171	92171-1554	CLAMP	1	1			
130	130G0625	BOLT-FLANGED,6X25	1	1			
130A	130J0612	BOLT-FLANGED	1	1			
130B	130Z0620	BOLT-FLANGED	4	4			

This catalog covers:

'04~'05 KSV700-A1/A2 Engine

GRID NO.

C-5

This grid covers:

Crankcase

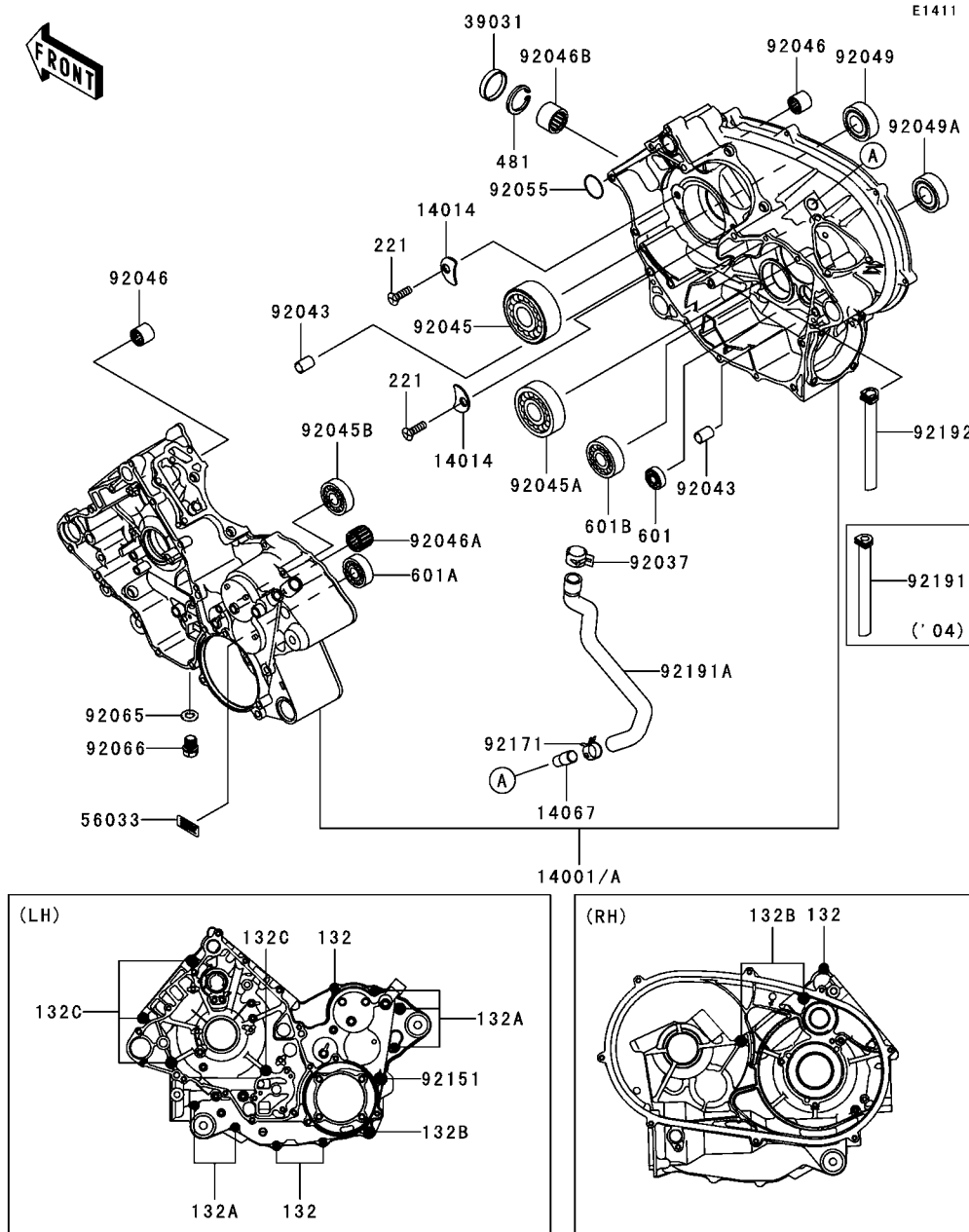

Ref. No.	Part No.	Description	Spec Code	Quantity-KSV700			
				'04	'05		
				A1	A2		
14001	14001-0028	SET-CRANKCASE			1		
14001A	14001-1322	SET-CRANKCASE			1		
14014	14014-0006	PLATE-POSITION			2	2	
14067	14067-006	FITTING,BREATHER			1	1	
39031	39031-1070	CAP-END			1	1	
56033	56033-0021	LABEL-MANUAL,OIL LEVEL			1	1	
92037	92037-1730	CLAMP			1	1	
92043	92043-1506	PIN			2	2	
92045	92045-0012	BEARING-BALL,5208X2-A-ECG45			1	1	
92045A	92045-1190	BEARING-BALL,6306SH2			1	1	
92045B	92045-1389	BEARING-BALL			1	1	
92046	92046-1118	BEARING-NEEDLE,TA202715ZE			2	2	
92046A	92046-1143	BEARING-NEEDLE			1	1	
92046B	92046-1277	BEARING-NEEDLE			1	1	
92049	92049-1452	SEAL-OIL,TC35508			1	1	
92049A	92049-1575	SEAL-OIL			1	1	
92055	92055-1136	RING-O,25.7X2.4			1	1	
92065	92065-097	GASKET,12X22X2			1	1	
92066	92066-1174	PLUG,OIL DRAIN,12X15			1	1	
92151	92151-1689	BOLT,8MM			1	1	
92171	92171-0329	CLAMP			1	1	
92191	92191-1449	TUBE,OIL RETURN			1		
92191A	92191-1740	TUBE,BREATHER			1	1	
92192	92192-0057	TUBE,OIL RETURN			1		
132	132Y0640	BOLT-FLANGED-SMALL			4	4	
132A	132Y0665	BOLT-FLANGED-SMALL			5	5	
132B	132Y08110	BOLT-FLANGED-SMALL			3	3	
132C	132Y0875	BOLT-FLANGED-SMALL			4	4	
221	221B0616	SCREW-CSK-CROS,6X16			2	2	
481	481J3700	CIRCLIP-TYPE-C,37MM			1	1	
601	601A6000	BEARING-BALL			1	1	
601A	601A6004	BEARING-BALL,#6004			1	1	
601B	601A6304	BEARING-BALL,#6304			1	1	

This catalog covers:

'04~'05 KSV700-A1/A2 Engine

GRID NO.

C-6

This grid covers:

Engine Cover(s)

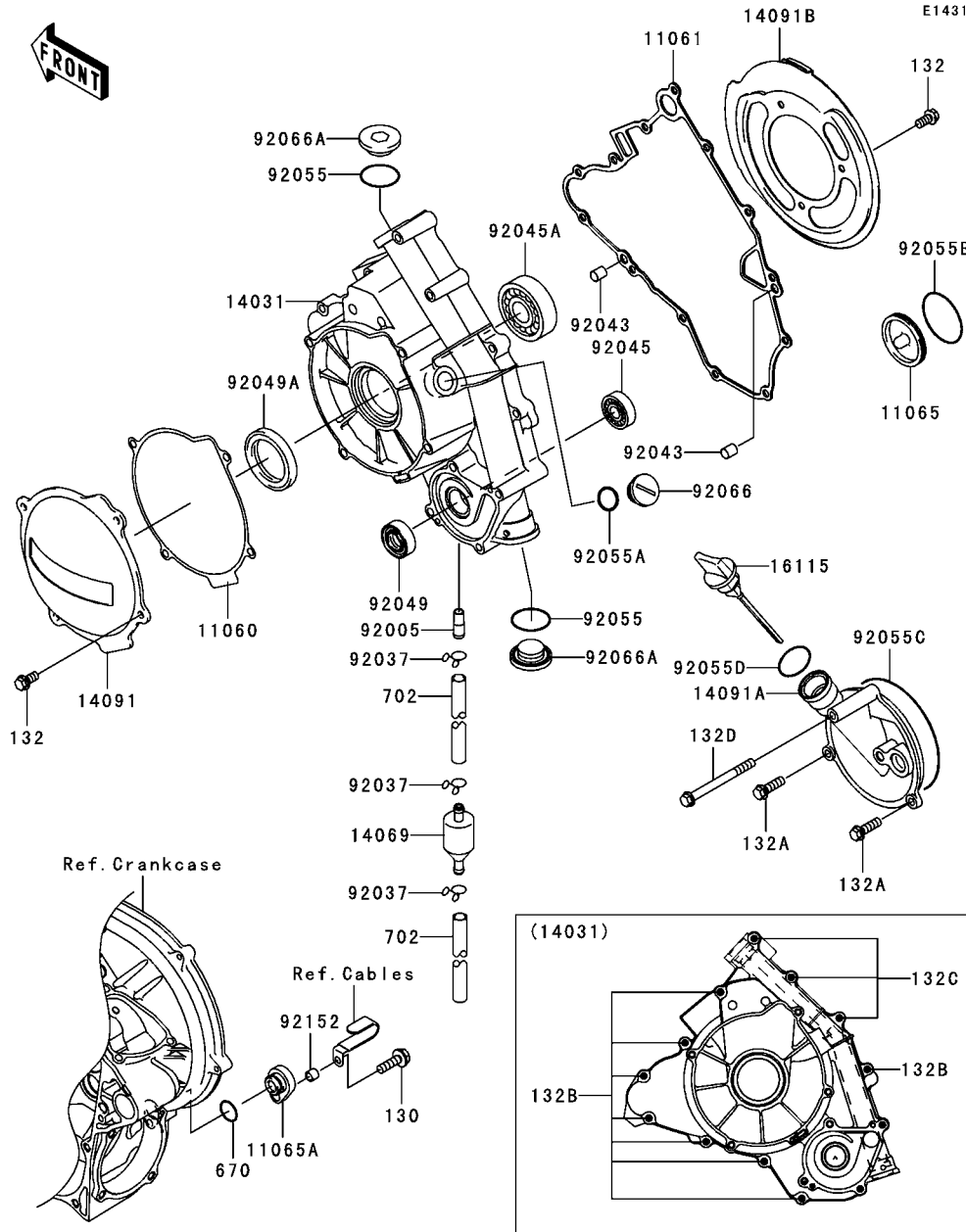

Ref. No.	Part No.	Description	Spec Code	Quantity-KSV700			
				'04	'05		
				A1	A2		
11060	11060-1717	GASKET,BLANK	1	1			
11061	11061-1119	GASKET	1	1			
11065	11065-1151	CAP	1	1			
11065A	11065-1252	CAP,OIL COVER	1	1			
14031	14031-0030	COVER-GENERATOR	1	1			
14069	14069-1051	BREATHER	1	1			
14091	14091-1538	COVER,GENERATOR COVER	1	1			
14091A	14091-1543	COVER,OIL	1	1			
14091B	14091-1571	COVER,BELT CONVERTER	1	1			
16115	16115-0001	CAP-OIL FILLER	1	1			
92005	92005-1369	FITTING	1	1			
92037	92037-147	CLAMP,TUBE	3	3			
92043	92043-1263	PIN,6.2X8X14	2	2			
92045	92045-1246	BEARING-BALL,6901	1	1			
92045A	92045-1403	BEARING-BALL	1	1			
92049	92049-1228	SEAL-OIL,AC037AE0	1	1			
92049A	92049-1576	SEAL-OIL	1	1			
92055	92055-1136	RING-O,25.7X2.4	2	2			
92055A	92055-1146	RING-O	1	1			
92055B	92055-1279	RING-O,44.7X2.4	1	1			
92055C	92055-1632	RING-O	1	1			
92055D	92055-2185	RING-O,20MM	1	1			
92066	92066-0011	PLUG,COVER	1	1			
92066A	92066-0012	PLUG,25X8	2	2			
92152	92152-1332	COLLAR	1	1			
130	130Z0620	BOLT-FLANGED	1	1			
132	132Y0612	BOLT-FLANGED-SMALL	7	7			
132A	132Y0620	BOLT-FLANGED-SMALL	2	2			
132B	132Y0630	BOLT-FLANGED-SMALL	8	8			
132C	132Y0655	BOLT-FLANGED-SMALL	3	3			
132D	132Y0665	BOLT-FLANGED-SMALL	1	1			
670	670D2014	O RING, 14MM	1	1			
702	702A07035	TUBE-RUBBER,7X10X35	2	2			

This catalog covers:

'04~'05 KSV700-A1/A2 Engine

GRID NO.

C-7

This grid covers:

Carburetor

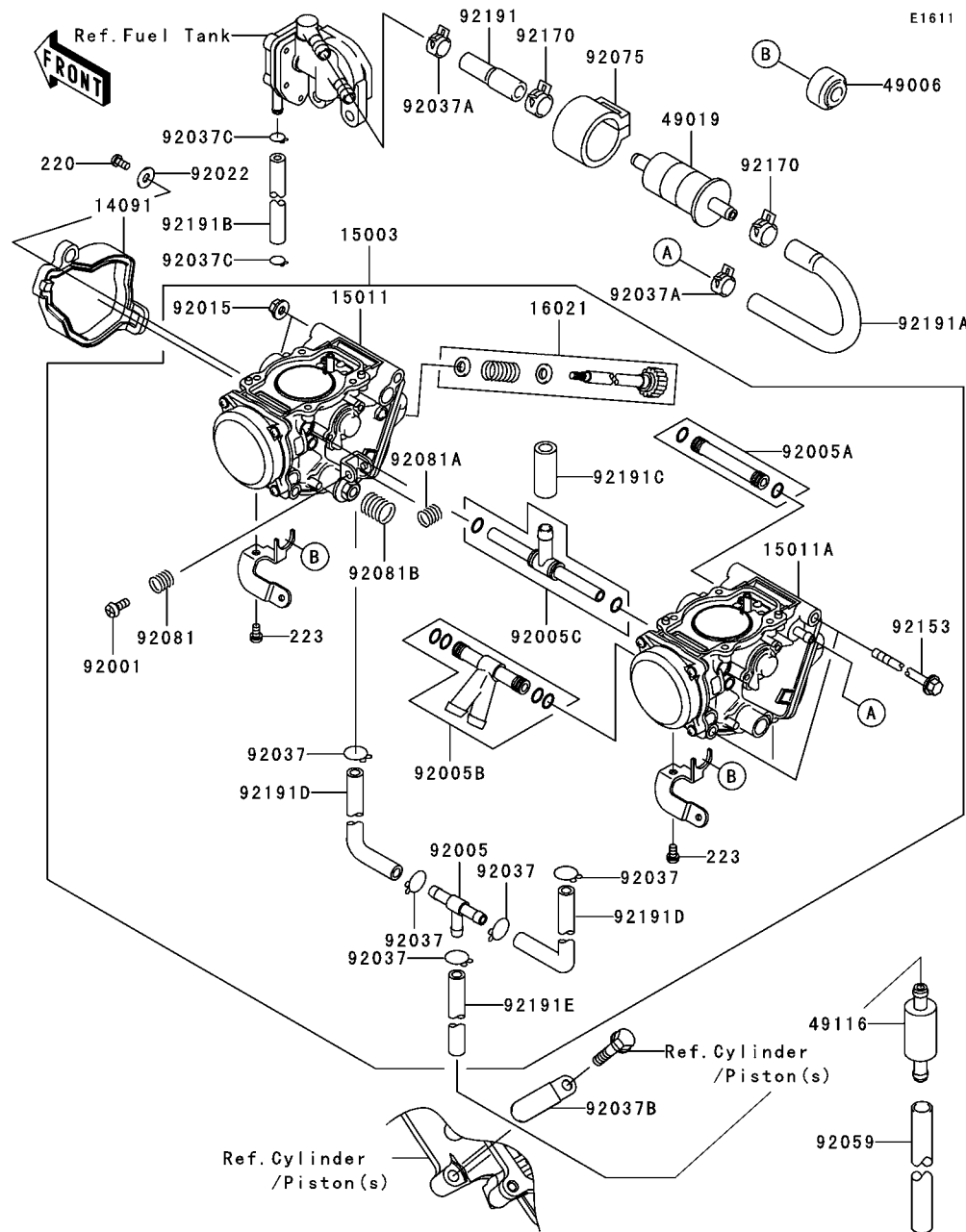

Ref. No.	Part No.	Description	Spec Code	Quantity-KSV700			
				'04	'05		
				A1	A2		
14091	14091-1196	COVER,THROTTLE CABLE		1	1		
15003	15003-0019	CARBURETOR-ASSY		1	1		
15011	15011-0015	CARBURETOR,FR		1	1		
15011A	15011-0016	CARBURETOR,RR		1	1		
16021	16021-1223	SCREW-THROTTLE STOP		1	1		
49006	49006-1353	BOOT,STARTER CABLE		2	2		
49019	49019-1055	FILTER-FUEL		1	1		
49116	49116-1126	VALVE-ASSY		1	1		
92001	92001-1998	BOLT,THROTTLE ADJUST		1	1		
92005	92005-1112	FITTING,FUEL,T-TYPE		1	1		
92005A	92005-1375	FITTING		1	1		
92005B	92005-1376	FITTING		1	1		
92005C	92005-1385	FITTING		1	1		
92015	92015-1259	NUT,FLANGED,5MM		2	2		
92022	92022-1380	WASHER,5.2X13X1		1	1		
92037	92037-1201	CLAMP,TUBE		5	5		
92037A	92037-1505	CLAMP,TUBE		2	2		
92037B	92037-1539	CLAMP,L=45		1	1		
92037C	92037-1610	CLAMP		2	2		
92059	92059-1736	TUBE,7X10X100		1	1		
92075	92075-1853	DAMPER,FUEL FILTER		1	1		
92081	92081-1620	SPRING,THROTTLE ADJUST UPP		1	1		
92081A	92081-1621	SPRING,THROTTLE ADJUST LWR		1	1		
92081B	92081-1622	SPRING,THROTTLE ADJUST CNT		1	1		
92153	92153-1068	BOLT,5X143		2	2		
92170	92170-1492	CLAMP		2	2		
92191	92191-0017	TUBE,TAP-FUEL FILTER		1	1		
92191A	92191-0018	TUBE,FUEL FILTER-CARBURETOR		1	1		
92191B	92191-1251	TUBE		1	1		
92191C	92191-1672	TUBE,7X11X25		1	1		
92191D	92191-1673	TUBE,4.5X8X65		2	2		
92191E	92191-1674	TUBE,4.5X8X420		1	1		
220	220B0408	SCREW-PAN-CROS		1	1		
223	223D0408	SCREW-PAN-WS-CROS		2	2		

This catalog covers:

'04~'05 KSV700-A1/A2 Engine

GRID NO.

C-8

This grid covers:

Carburetor Parts(1/2)

E1612

Ref. No.	Part No.	Description	Spec Code	Quantity-KSV700			
				'04	'05		
				A1	A2		
13280	13280-1096	HOLDER,JET	2	2			
14041	14041-1090	CAP-CHAMBER,MIXING	2	2			
14090	14090-1984	COVER,AIR CUT VALVE	2	2			
16007	16007-1120	SEAT-SPRING,THROTTLE VALVE	2	2			
16014	16014-1105	SCREW-PILOT AIR	2	2			
16016	16016-1117	PLUNGER	2	2			
16017	16017-1441	JET-NEEDLE	2	2			
16030	16030-1007	VALVE-FLOAT	2	2			
16031	16031-1097	FLOAT	2	2			
16035	16035-1055	JET-AIR,LEAK	2	2			
16044	16044-007	CLAMP,FLOAT VALVE	2	2			
16126	16126-1226	VALVE,VACUUM	2	2			
16187	16187-0021	NEEDLE-JET,NBZH	2	2			
43028	43028-1085	DIAPHRAGM,AIR CUT VALVE	2	2			
92009	92009-1549	SCREW,4X4.4	8	8			
92009A	92009-1551	SCREW,DRAIN,M6X0.75	2	2			
92055	92055-1589	RING-O,FLOAT CHAMBER	2	2			
92063	92063-1013	JET-MAIN,#140	1	1			
92063A	92063-1014	JET-MAIN,#135	1	1			
92063B	92063-1015	JET-MAIN,#138	AR	AR			
	(OPTION)						
92063C	92063-1016	JET-MAIN,#142	AR	AR			
	(OPTION)						
92063D	92063-1017	JET-MAIN,#145	AR	AR			
	(OPTION)						
92063E	92063-1069	JET-MAIN,#125	AR	AR			
	(OPTION)						
92063F	92063-1072	JET-MAIN,#120	AR	AR			
	(OPTION)						
92063G	92063-1074	JET-MAIN,#128	AR	AR			
	(OPTION)						
92063H	92063-1075	JET-MAIN,#130	AR	AR			
	(OPTION)						
92063I	92063-1076	JET-MAIN,#132	AR	AR			
	(OPTION)						
92064	92064-0005	JET-PILOT,#40	2	2			
92093	92093-1046	SEAL,"U"RING	2	2			
92145	92145-0097	SPRING,AIR CUT VALVE	1	1			
92145A	92145-1227	SPRING,VACUUM VALVE	2	2			
92145B	92145-1450	SPRING,AIR CUT VALVE	1	1			
220	220D0408	SCREW-PAN-CROS	6	6			

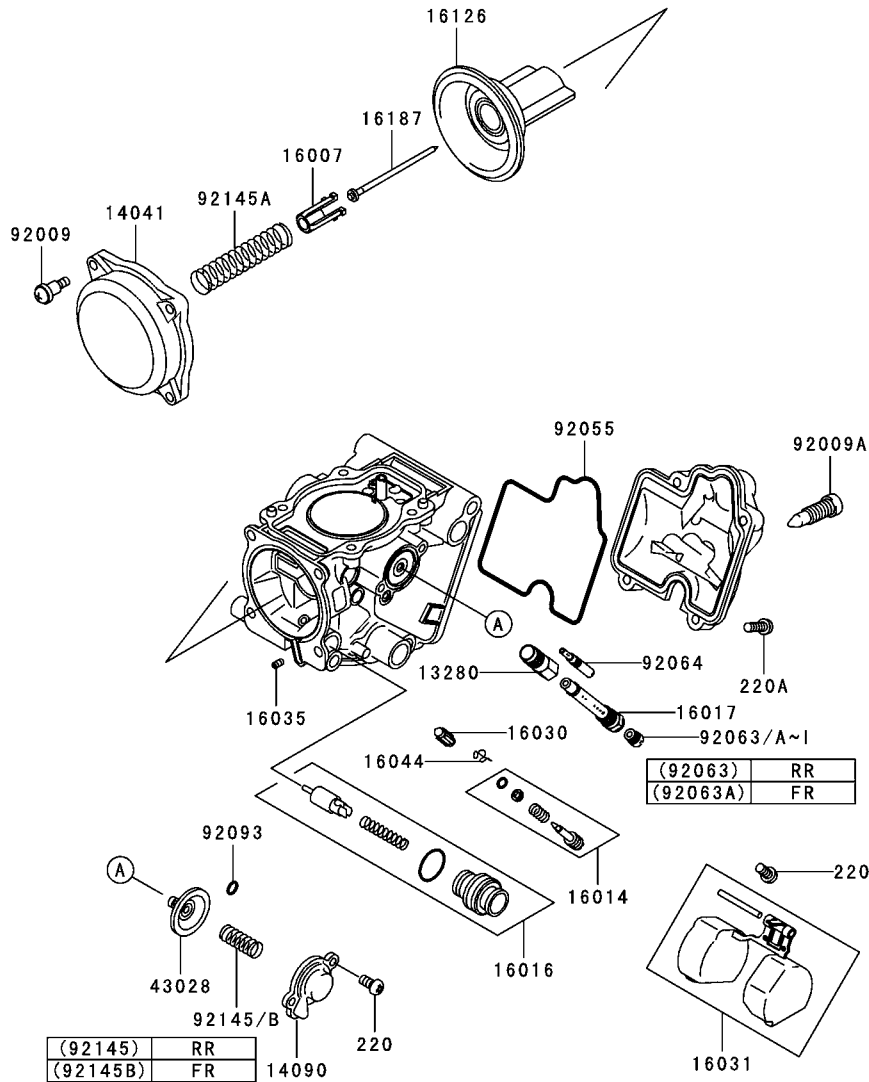

This catalog covers:

'04~'05 KSV700-A1/A2 Engine

GRID NO.

C-9

This grid covers:

Carburetor Parts(2/2)

E1612

Ref. No.	Part No.	Description	Spec Code	Quantity-KSV700			
				'04	'05		
				A1	A2		
220A	220D0414	SCREW-PAN-CROS		8	8		

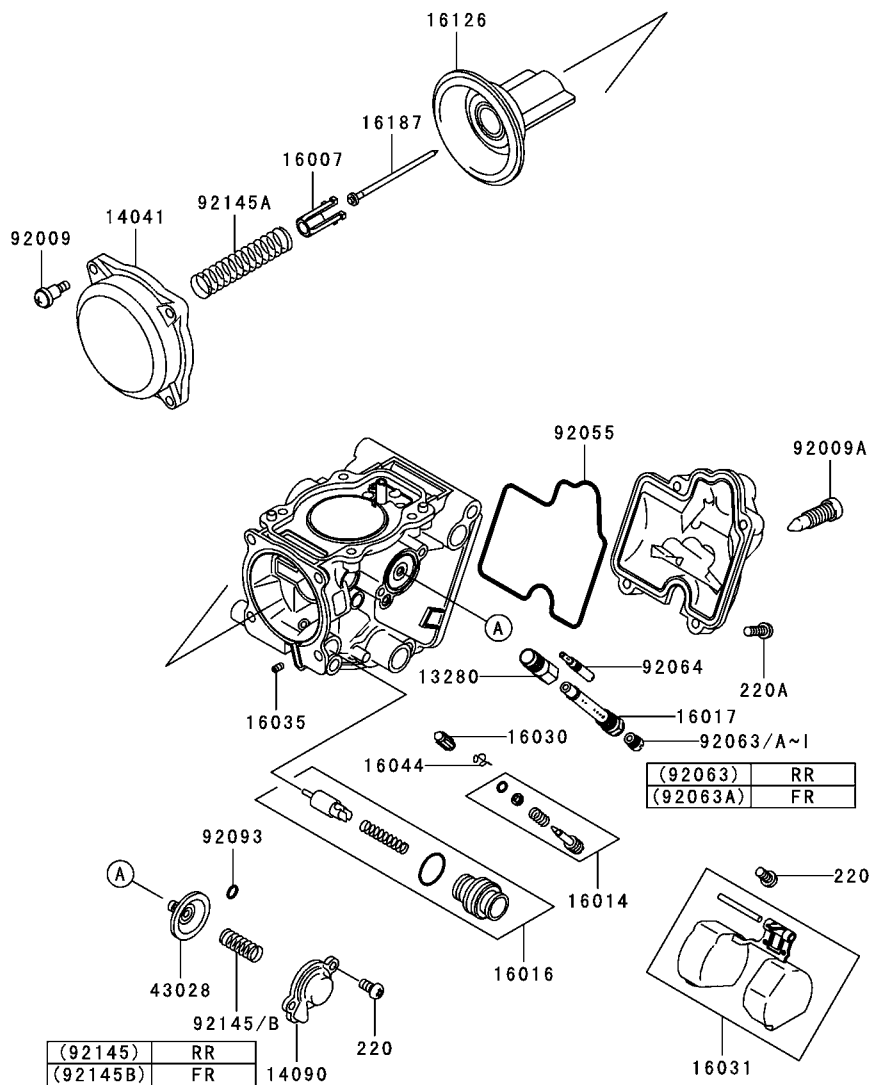

This catalog covers:

'04~'05 KSV700-A1/A2 Engine

GRID NO.

C-10

This grid covers:

Oil Pump

E1710

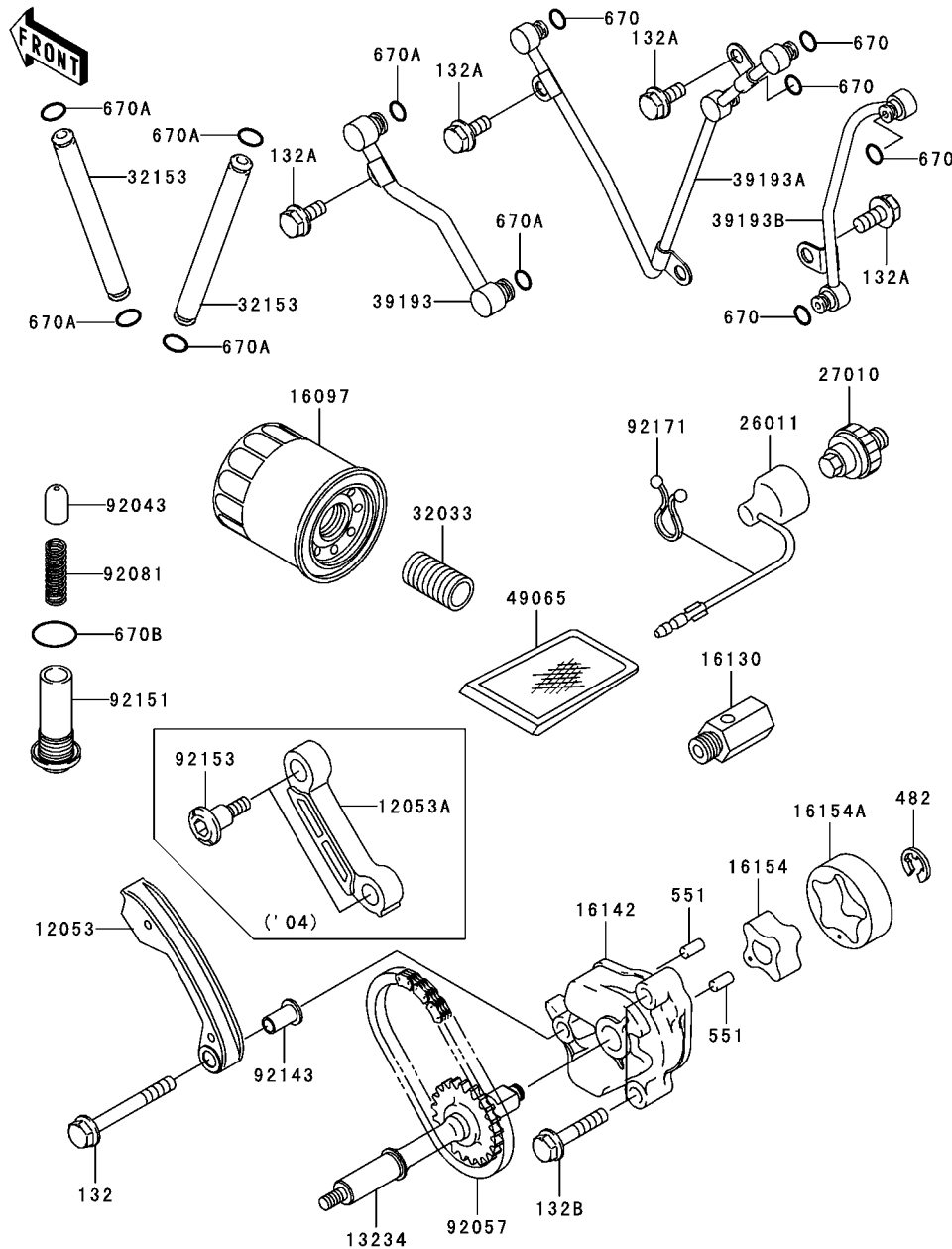

Ref. No.	Part No.	Description	Spec Code	Quantity-KSV700			
				'04	'05		
				A1	A2		
12053	12053-1440	GUIDE-CHAIN,SLACK	1	1			
12053A	12053-1443	GUIDE-CHAIN,TENSION	1				
13234	13234-1112	SHAFT-COMP,OIL PUMP	1	1			
16097	16097-1072	FILTER-ASSY-OIL	1	1			
16130	16130-1058	VALVE-ASSY-RELIEF	1	1			
16142	16142-1162	COVER-PUMP	1	1			
16154	16154-2059	ROTOR-PUMP,INNER	1	1			
16154A	16154-2060	ROTOR-PUMP,OUTER	1	1			
26011	26011-1755	WIRE-LEAD	1	1			
27010	27010-1313	SWITCH,OIL PRESSURE	1	1			
32033	32033-1535	PIPE,OIL FILTER	1	1			
32153	32153-1189	PIPE	2	2			
39193	39193-1052	PIPE-OIL,CRANKSHAFT	1	1			
39193A	39193-1053	PIPE-OIL,CRANKCASE,LH	1	1			
39193B	39193-1054	PIPE-OIL,CRANKCASE,RH	1	1			
49065	49065-1086	FILTER-OIL	1	1			
92043	92043-076	PIN	1	1			
92057	92057-1538	CHAIN,OIL PUMP	1	1			
92081	92081-112	SPRING	1	1			
92143	92143-1857	COLLAR	1	1			
92151	92151-1781	BOLT	1	1			
92153	92153-1200	BOLT	2				
92171	92171-1329	CLAMP	1	1			
132	132J0650	BOLT-FLANGED-SMALL	1	1			
132A	132Y0612	BOLT-FLANGED-SMALL	4	4			
132B	132Y0630	BOLT-FLANGED-SMALL	2	2			
482	482J6000	CIRCLIP-TYPE-E,6MM	1	1			
551	551A0408	PIN-DOWEL,4X8	2	2			
670	670D1505	O RING	5	5			
670A	670D1507	O RING,7MM	6	6			
670B	670D2016	O RING,16MM	1	1			

This catalog covers:

'04~'05 KSV700-A1/A2 Engine

GRID NO.

C-11

This grid covers:

Generator

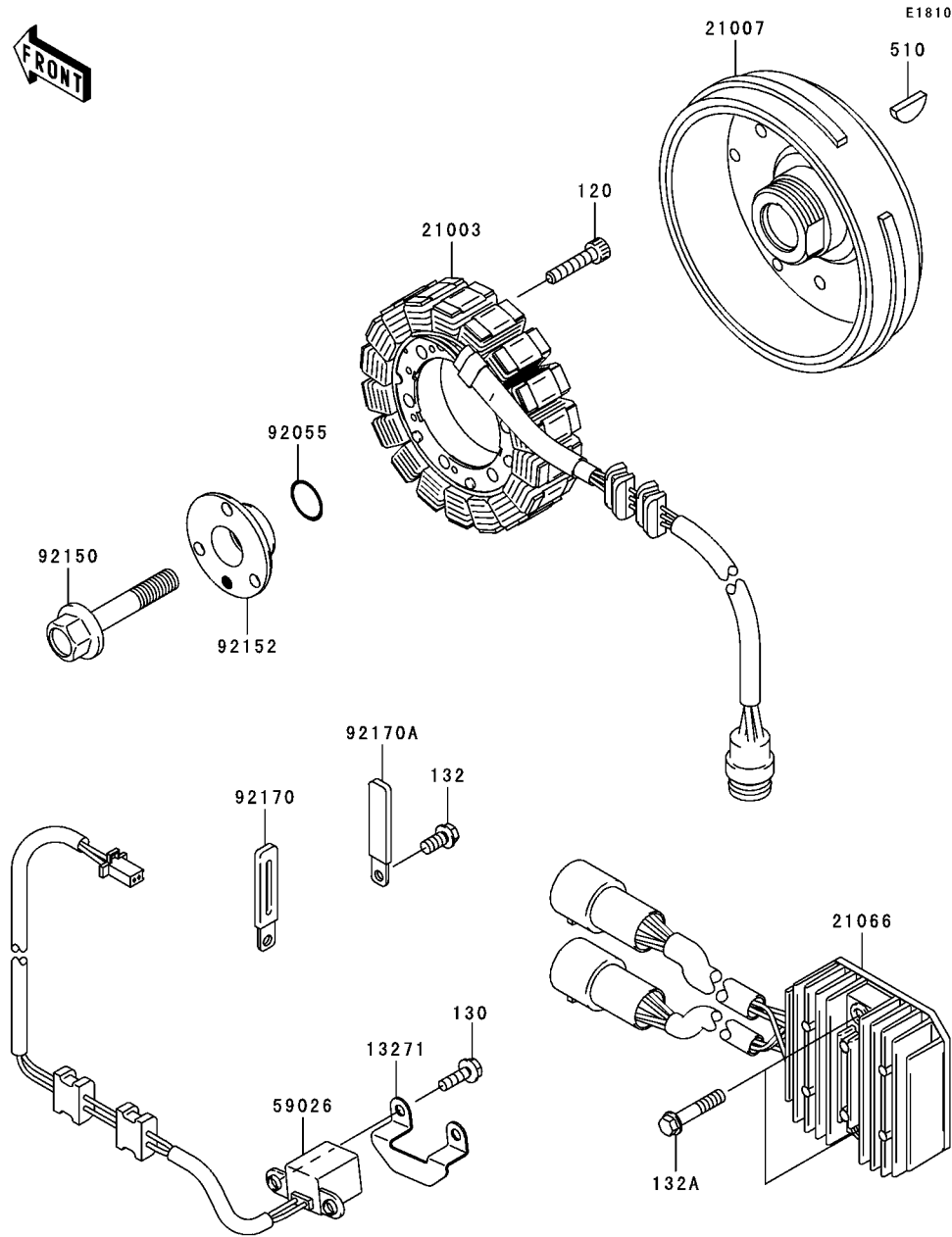

Ref. No.	Part No.	Description	Quantity-KSV700			
			'04	'05		
			A1	A2		
13271	13271-1369	PLATE	1	1		
21003	21003-0003	STATOR	1	1		
21007	21007-1367	ROTOR	1	1		
21066	21066-1112	REGULATOR-VOLTAGE	1	1		
59026	59026-1159	COIL-PULSING	1	1		
92055	92055-1215	RING-O,19.8X2.2	1	1		
92150	92150-1987	BOLT,PULLEY	1	1		
92152	92152-1467	COLLAR,20X51X17	1	1		
92170	92170-1514	CLAMP	1	1		
92170A	92170-1925	CLAMP	1	1		
120	120P0628	BOLT-SOCKET,6X28	3	3		
130	130G0516	BOLT-FLANGED	2	2		
132	132Y0612	BOLT-FLANGED-SMALL	1	1		
132A	132Y0630	BOLT-FLANGED-SMALL	2	2		
510	510A4200	KEY-WOODRUFF	1	1		

This catalog covers:

'04~'05 KSV700-A1/A2 Engine

GRID NO.

C-12

This grid covers:

Ignition System

E1830

Ref. No.	Part No.	Description	Spec Code	Quantity-KSV700			
				'04	'05		
				A1	A2		
21119	21119-0032	IGNITER	1	1			
21121	21121-1316	COIL-IGNITION	2	2			
21130	21130-1071	CAP-SPARK PLUG	2	2			
92070	92070-1209	PLUG-SPARK,CR7E(NGK)	2	2			
132	132H0616	BOLT-FLANGED-SMALL	2	2			
132A	132J0616	BOLT-FLANGED-SMALL	2	2			

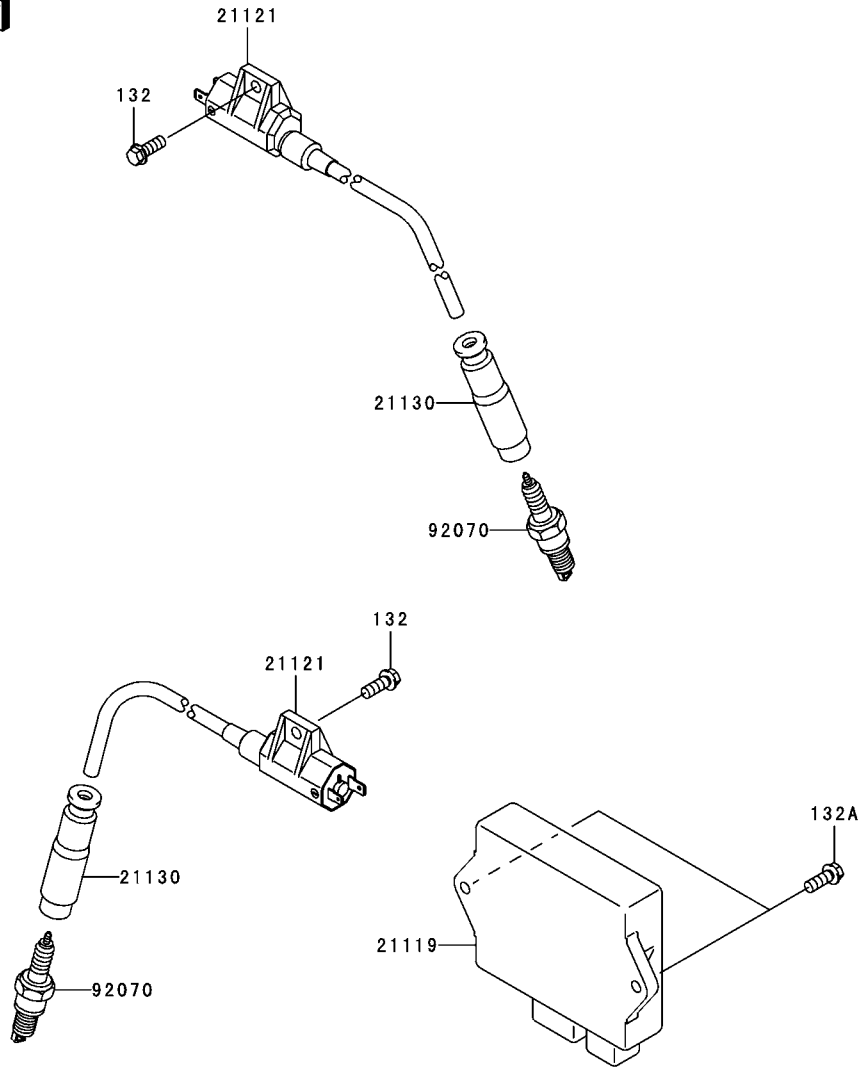

This catalog covers:

'04~'05 KSV700-A1/A2 Engine

GRID NO.

C-13

This grid covers:

Starter Motor

E1840

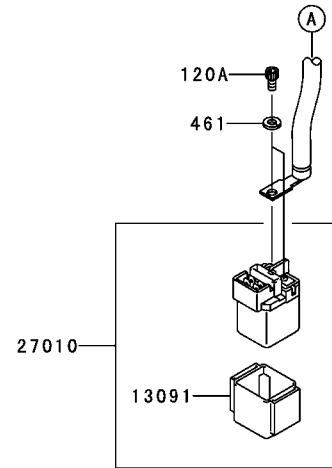
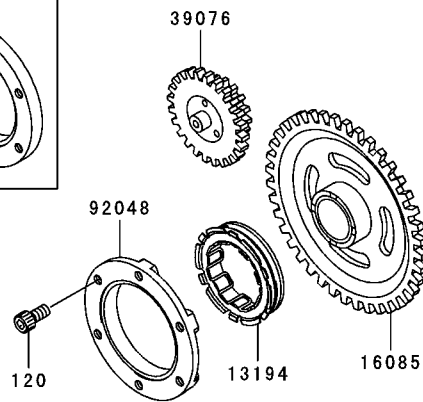
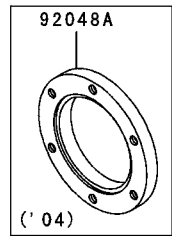
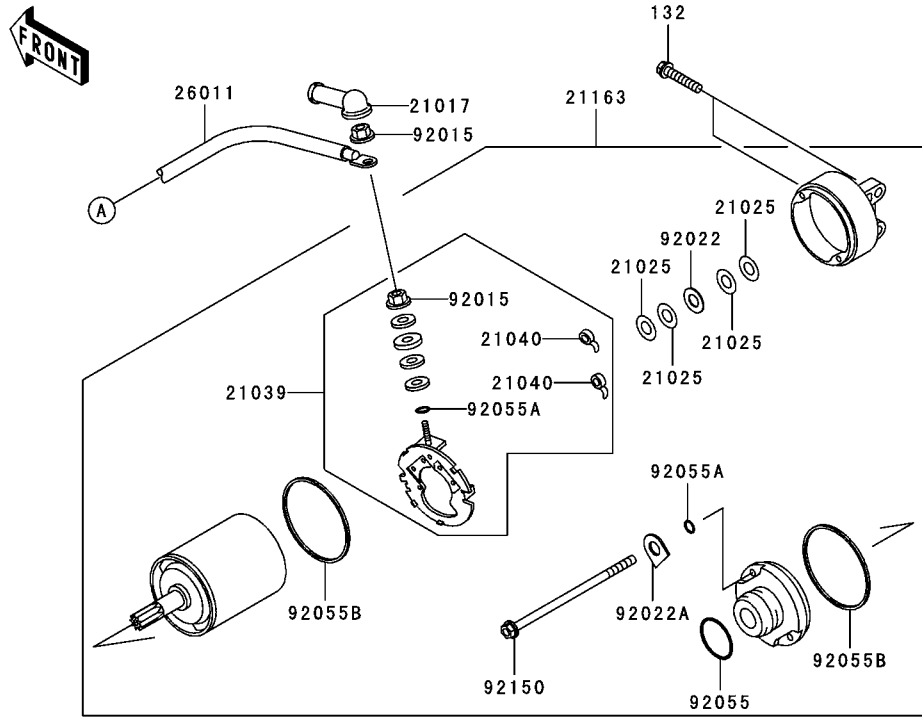

Ref. No.	Part No.	Description	Spec Code	Quantity-KSV700			
				'04	'05		
				A1	A2		
13091	13091-1992	HOLDER	1	1			
13194	13194-1094	CLUTCH-ONEWAY	1	1			
16085	16085-1238	GEAR,STARTER	1	1			
21017	21017-017	GROMMET,STARTER TERMINAL	1	1			
21025	21025-011	WASHER,9.1X18X0.2	4	4			
21039	21039-1063	BRUSH,CARBON	1	1			
21040	21040-1057	SPRING-BRUSH	2	2			
21163	21163-1320	STARTER-ELECTRIC	1	1			
26011	26011-1845	WIRE-LEAD	1	1			
27010	27010-1376	SWITCH,MAGNETIC	1	1			
39076	39076-1076	LIMITER,STARTER	1	1			
92015	92015-1476	NUT,STARTER MOTOR	2	2			
92022	92022-1132	WASHER,9.1X18X0.8	1	1			
92022A	92022-1458	WASHER,LOCK,T=2.0	2	2			
92048	92048-0002	RACE,ONE WAY CLUTCH		1			
92048A	92048-1090	RACE,ONEWAY CLUTCH	1				
92055	92055-1276	RING-O	1	1			
92055A	92055-1370	RING-O,4.5X2.0	3	3			
92055B	92055-1381	RING-O,STARTER MOTOR	2	2			
92150	92150-1243	BOLT	2	2			
120	120P0816	BOLT-SOCKET	6	6			
120A	120S0510	BOLT-SOCKET	2	2			
132	132Y0630	BOLT-FLANGED-SMALL	2	2			
461	461K0500	WASHER-SPRING,5MM,BLACK	2	2			

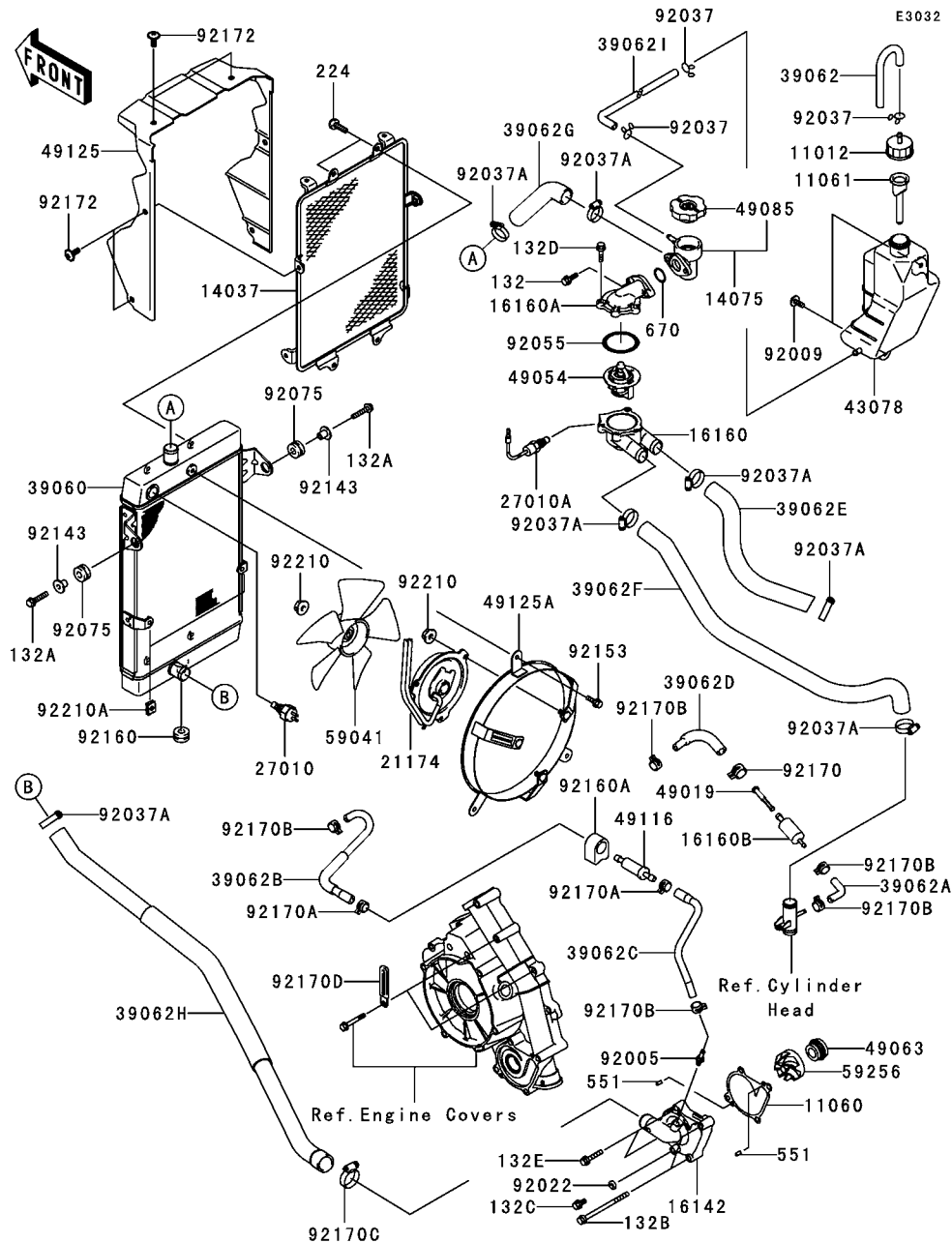

Ref. No.	Part No.	Description	Quantity-KSV700			
			'04	'05		
			A1	A2		
11012	11012-1854	CAP	1	1		
11060	11060-1964	GASKET,WATER PUMP	1	1		
11061	11061-0043	GASKET	1	1		
14037	14037-0017	SCREEN	1	1		
14075	14075-1115	CAP-ASSY,PRESSURE	1	1		
16142	16142-0002	COVER-PUMP,WATER	1	1		
16160	16160-1112	BODY,THERMOSTAT,LWR	1	1		
16160A	16160-1113	BODY,THERMOSTAT,UPP	1	1		
16160B	16160-1359	BODY	1	1		
21174	21174-0001	MOTOR-ELECTRIC	1	1		
27010	27010-1202	SWITCH,FAN	1	1		
27010A	27010-1346	SWITCH,SENSOR WATER	1	1		
39060	39060-0006	RADIATOR	1	1		
39062	39062-0002	HOSE-COOLING,BREATHER	1	1		
39062A	39062-1816	HOSE-COOLING,HEAD-FILTER	1	1		
39062B	39062-1817	HOSE-COOLING,CARB-VALVE	1	1		
39062C	39062-1818	HOSE-COOLING,VALVE-WATER PUMP	1	1		
39062D	39062-1858	HOSE-COOLING,FILTER-CARB	1	1		
39062E	39062-1920	HOSE-COOLING,FR HEAD-THERMO	1	1		
39062F	39062-1921	HOSE-COOLING,RR HEAD-THERMO	1	1		
39062G	39062-1922	HOSE-COOLING,THERMO-RADIATOR	1	1		
39062H	39062-1923	HOSE-COOLING,RAD-WATER PUMP	1	1		
39062I	39062-1924	HOSE-COOLING,RESERVOIR-THERMO	1	1		
43078	43078-0004	RESERVOIR,TANK	1	1		
49019	49019-1068	FILTER-WATER	1	1		
49054	49054-1055	THERMOSTAT	1	1		
49063	49063-1055	SEAL-MECHANICAL,WATER	1	1		
49085	49085-1067	CAP-ASSY-PRESSURE	1	1		
49116	49116-1190	VALVE-ASSY	1	1		
49125	49125-0003	SHROUD	1	1		
49125A	49125-0007	SHROUD	1	1		
59041	59041-0001	FAN	1	1		
59256	59256-1069	IMPELLER	1	1		
92005	92005-1337	FITTING	1	1		
92009	92009-1621	SCREW,6X16	2	2		
92022	92022-304	WASHER,6.2X11X1	1	1		
92037	92037-147	CLAMP,TUBE	3	3		
92037A	92037-1589	CLAMP,COOLING HOSE	7	7		
92055	92055-1279	RING-O,44.7X2.4	1	1		
92075	92075-209	DAMPER	2	2		

This catalog covers:

'04~'05 KSV700-A1/A2 Engine

GRID NO.

D-3

This grid covers:

Radiator(2/2)

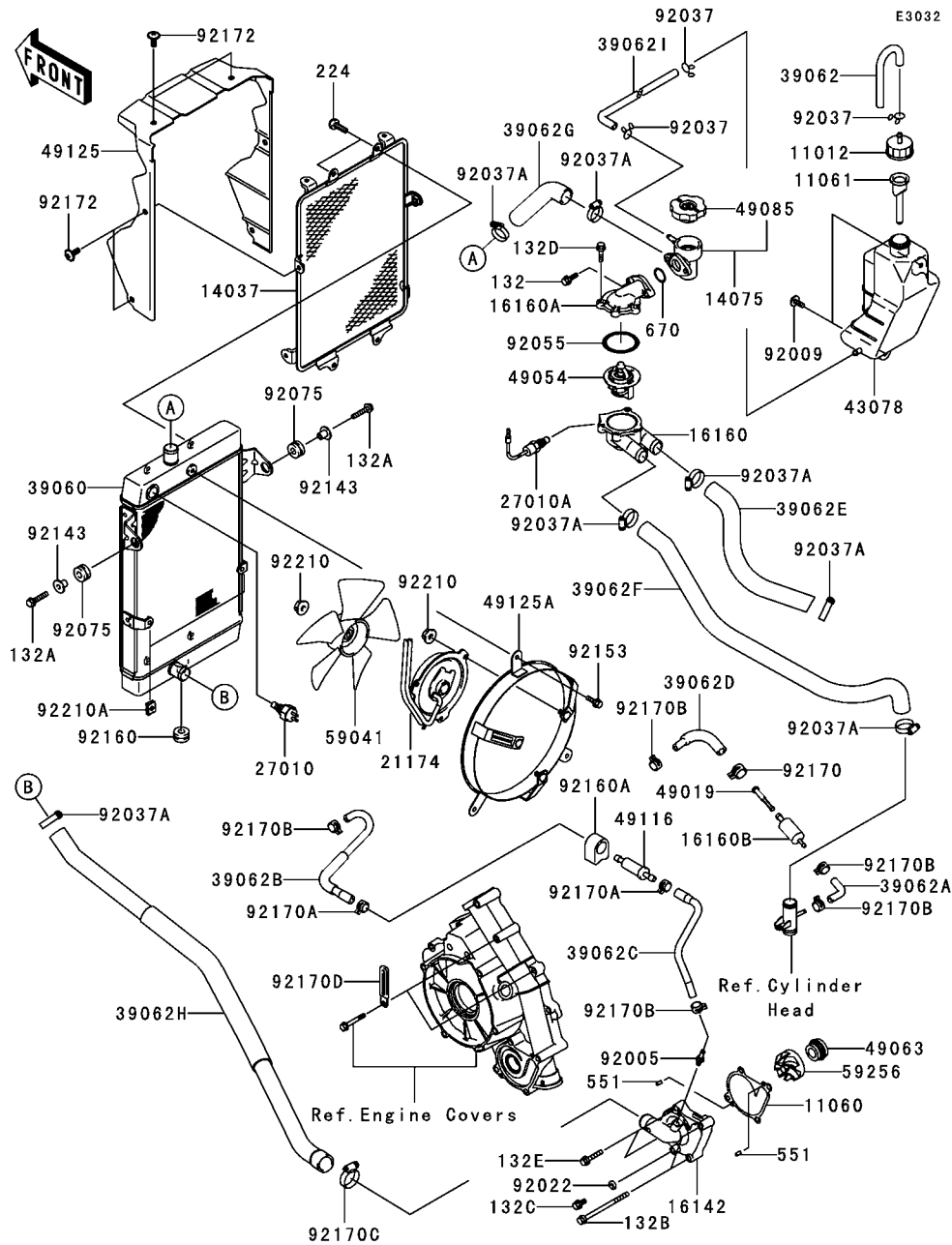

Ref. No.	Part No.	Description	Spec Code	Quantity-KSV700			
				'04	'05		
				A1	A2		
92143	92143-1353	COLLAR	2	2			
92153	92153-0456	BOLT	3	3			
92160	92160-1007	DAMPER	1	1			
92160A	92160-1451	DAMPER, VALVE	1	1			
92170	92170-1491	CLAMP	1	1			
92170A	92170-1492	CLAMP	2	2			
92170B	92170-1493	CLAMP	5	5			
92170C	92170-1497	CLAMP	1	1			
92170D	92170-1514	CLAMP	2	2			
92172	92172-0005	SCREW,6X10	6	6			
92210	92210-0085	NUT	4	4			
92210A	92210-0086	NUT	2	2			
132	132H0616	BOLT-FLANGED-SMALL	2	2			
132A	132H0625	BOLT-FLANGED-SMALL,6X25	2	2			
132B	132J0690	BOLT-FLANGED-SMALL	2	2			
132C	132Y0612	BOLT-FLANGED-SMALL	1	1			
132D	132Y0620	BOLT-FLANGED-SMALL	4	4			
132E	132Y0630	BOLT-FLANGED-SMALL	2	2			
224	224C0612	SCREW-PAN-WP-CROS	4	4			
551	551A0408	PIN-DOWEL,4X8	2	2			
670	670B2020	O RING,20MM	1	1			

This catalog covers:

'04~'05 KSV700-A1/A2 Engine

GRID NO.

D-4

This grid covers:

Front Bevel Gear

E3131

Ref. No.	Part No.	Description	Spec Code	Quantity-KSV700			
				'04	'05		
				A1	A2		
13048	13048-1088	CAM-DAMPER	1	1			
13107	13107-1516	SHAFT	1	1			
13262	13262-0014	GEAR,OUTPUT DRIVEN,27T	1	1			
13280	13280-1169	HOLDER	1	1			
41046	41046-1101	HOUSING-BEARING	1	1			
41046A	41046-1102	HOUSING-BEARING	1	1			
49022	49022-1192	GEAR-BEVEL,DRIVE,12T	1	1			
49022A	49022-1193	GEAR-BEVEL,DRIVNE,20T	1	1			
92009	92009-1667	SCREW	1	1			
92009A	92009-1914	SCREW,64MM	1	1			
92033	92033-1320	RING-SNAP	1	1			
92045	92045-1190	BEARING-BALL,6306SH2	1	1			
92045A	92045-1207	BEARING-BALL,62/28	1	1			
92049	92049-1529	SEAL-OIL	1	1			
92145	92145-1298	SPRING	1	1			
92151	92151-1688	BOLT	8	8			
92180	92180-1307	SHIM,DRIVEN,T=0.15	1	1			
92180A	92180-1308	SHIM,DRIVEN,T=0.20	1	1			
92180B	92180-1309	SHIM,DRIVEN,T=0.50	1	1			
92180C	92180-1310	SHIM,DRIVEN,T=0.80	1	1			
92180D	92180-1311	SHIM,DRIVE,T=0.15	1	1			
92180E	92180-1312	SHIM,DRIVE,T=0.20	1	1			
92180F	92180-1313	SHIM,DRIVE,T=0.50	1	1			
92180G	92180-1314	SHIM,DRIVE,T=0.80	1	1			
92180H	92180-1349	SHIM,DRIVEN,T=1.00	1	1			
92180I	92180-1350	SHIM,DRIVEN,T=1.20	1	1			
92180J	92180-1351	SHIM,DRIVE,T=1.00	1	1			
92180K	92180-1352	SHIM,DRIVE,T=1.20	1	1			
92210	92210-1294	NUT,30MM	2	2			
480	480J2800	CIRCLIP-TYPE-C,28MM	1	1			
601	601B6206	BEARING-BALL,#6206C3	1	1			
671	671D2585	O RING	1	1			

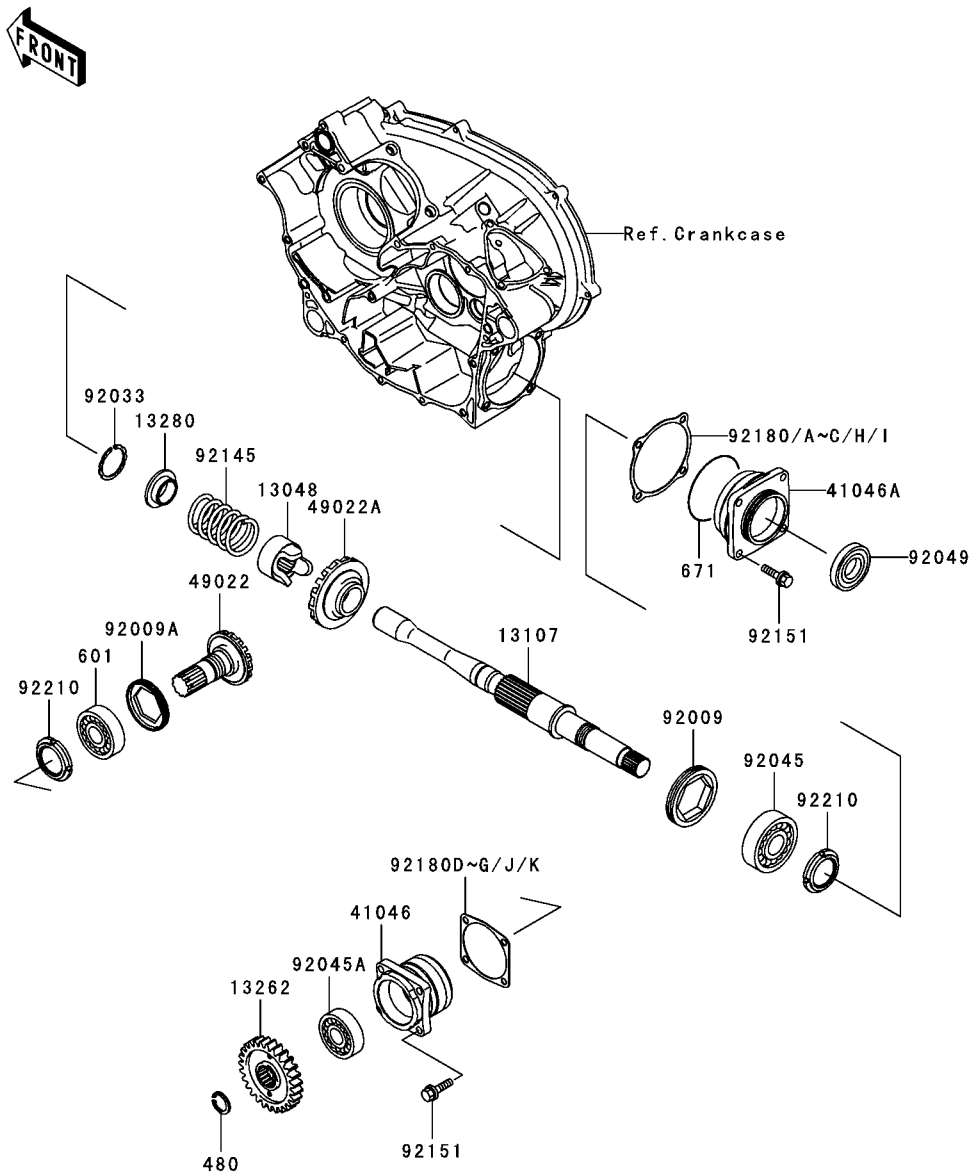

This catalog covers:

'04~'05 KSV700-A1/A2 Engine

GRID NO.

D-5

This grid covers:

Drive Shaft-Rear(1/2)

E3137

Ref. No.	Part No.	Description	Spec Code	Quantity-KSV700			
				'04	'05		
				A1	A2		
11052	11052-1348	BRACKET,REAR GUARD		1	1		
11053	11053-0216	BRACKET		1	1		
11065	11065-1260	CAP		2	2		
13168	13168-1687	LEVER,BRAKE		1	1		
13216	13216-0002	GEAR-COMP,RR,8T		1	1		
13271	13271-1938	PLATE,CAM		1	1		
13310	13310-1026	SHAFT-ASSY,RR DRIVE SHAFT		1	1		
14057	14057-0001	CASE-COMP-GEAR		1	1		
14091	14091-0028	COVER,RH		1	1		
14091A	14091-1422	COVER,LH		1	1		
41068	41068-0003	AXLE,RR,DRIVE SHAFT		1	1		
41080	41080-1483	DISC,PRESSURE		2	2		
41080A	41080-1484	DISC,SEPARATER		1	1		
41080B	41080-1538	DISC,FRICTION		2	2		
49006	49006-1358	BOOT,RR DRIVE SHAFT		1	1		
49022	49022-0004	GEAR-BEVEL,RR,35T		1	1		
92009	92009-1667	SCREW		1	1		
92037	92037-1104	CLAMP,HOSE		1	1		
92043	92043-1617	PIN,3X35		2	2		
92045	92045-1391	BEARING-BALL,BX30-1C3		1	1		
92049	92049-0012	SEAL-OIL,HTC40X58X8		2	2		
92049A	92049-0013	SEAL-OIL,SC40X52X7		2	2		
92055	92055-0004	RING-O,156.3X3.7		1	1		
92055A	92055-1136	RING-O,25.7X2.4		1	1		
92065	92065-023	GASKET		1	1		
92066	92066-1303	PLUG		1	1		
92072	92072-056	BAND,L=186		2	2		
92140	92140-1064	BALL,D/O#12		6	6		
92145	92145-1300	SPRING,RR DRIVE SHAFT		1	1		
92145A	92145-1553	SPRING,RETURN		2	2		
92151	92151-1909	BOLT,10X35		4	4		
92153	92153-0394	BOLT,12X40		2	2		
92153A	92153-0395	BOLT,8X35		4	4		
92153B	92153-0397	BOLT,10X40		2	2		
92170	92170-1763	CLAMP		1	1		
92170A	92170-2043	CLAMP		1	1		
92171	92171-1383	CLAMP		1	1		
92180	92180-1417	SHIM,55X64X0.15		AR	AR		
92180A	92180-1418	SHIM,55X64X0.20		AR	AR		
92180B	92180-1419	SHIM,55X64X0.50		AR	AR		

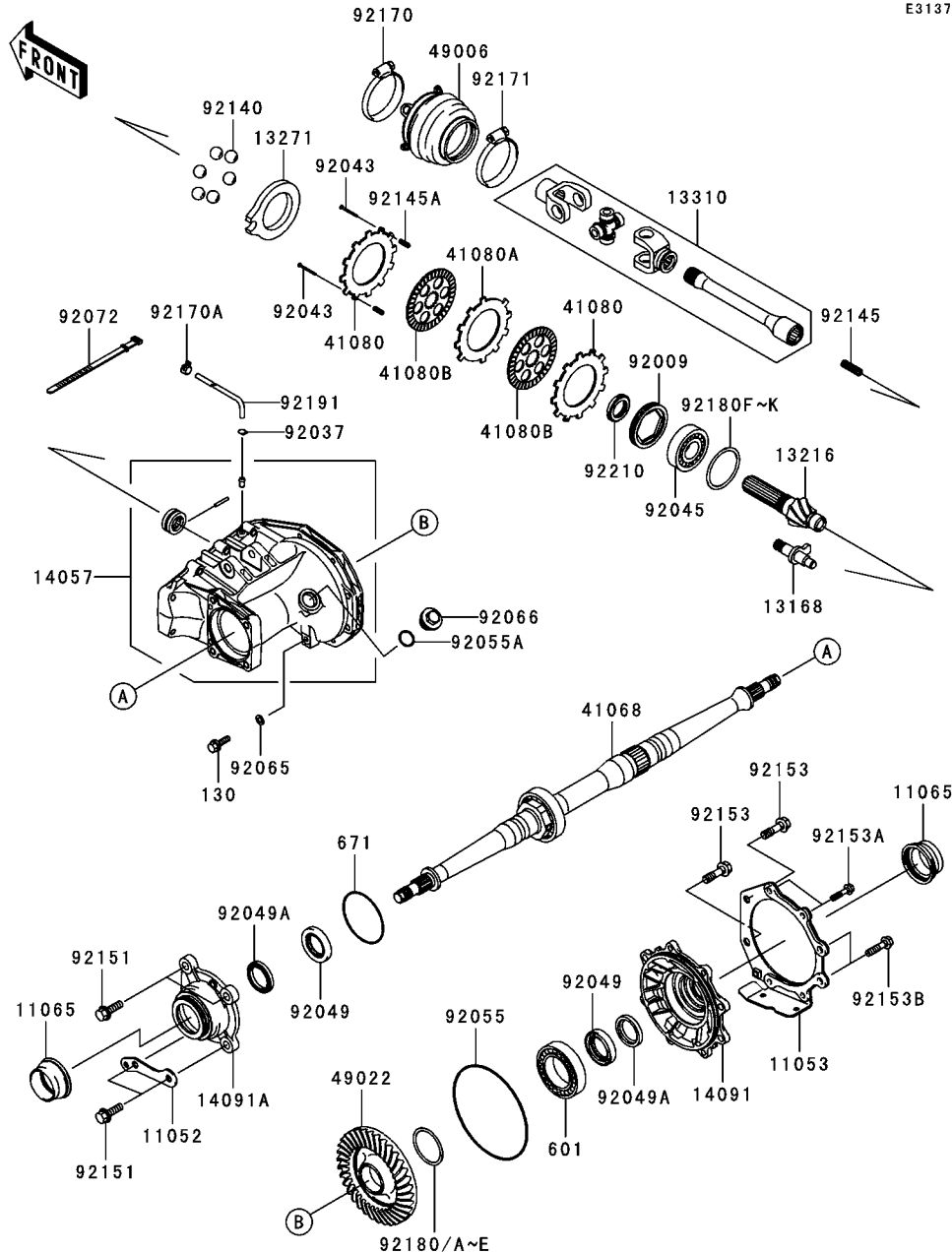

This catalog covers:

'04~'05 KSV700-A1/A2 Engine

GRID NO.

D-6

This grid covers:

Drive Shaft-Rear(2/2)

E3137

Ref. No.	Part No.	Description	Spec Code	Quantity-KSV700			
				'04	'05		
				A1	A2		
92180C	92180-1420	SHIM,55X64X0.80	AR	AR			
92180D	92180-1421	SHIM,55X64X1.00	AR	AR			
92180E	92180-1422	SHIM,55X64X1.20	AR	AR			
92180F	92180-1423	SHIM,60X72X0.15	AR	AR			
92180G	92180-1424	SHIM,60X72X0.20	AR	AR			
92180H	92180-1425	SHIM,60X72X0.50	AR	AR			
92180I	92180-1426	SHIM,60X72X0.80	AR	AR			
92180J	92180-1427	SHIM,60X72X1.00	AR	AR			
92180K	92180-1428	SHIM,60X72X1.20	AR	AR			
92191	92191-0014	TUBE,BREATHER,L=1450	1	1			
92210	92210-1294	NUT,30MM	1	1			
130	130G0816	BOLT-FLANGED,8X16	1	1			
601	601A6011	BEARING-BALL	1	1			
671	671D2585	O RING	1	1			

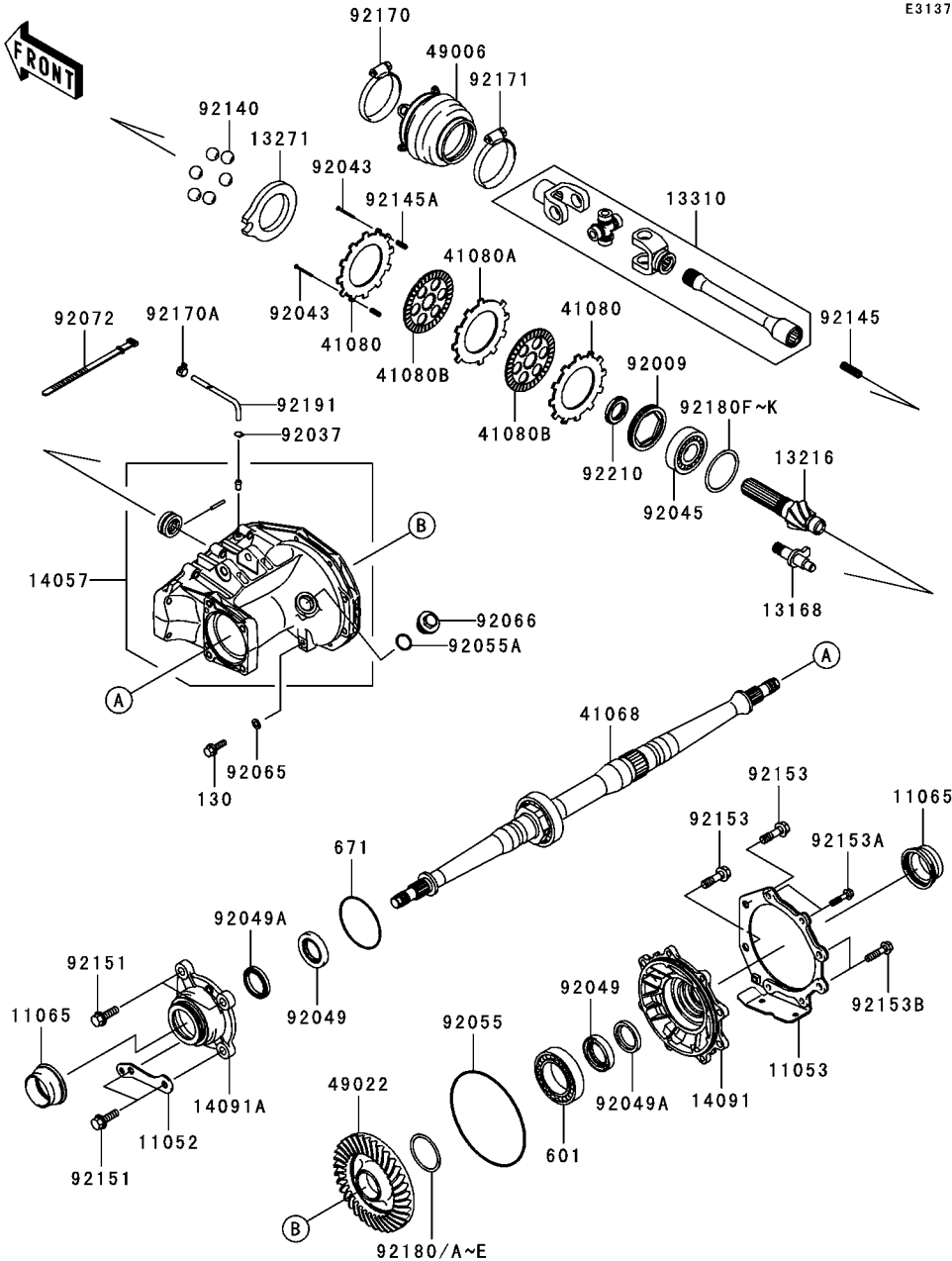

This catalog covers:

'04~'05 KSV700-A1/A2 Chassis

GRID NO.

E-3

This grid covers:

Frame

F2120

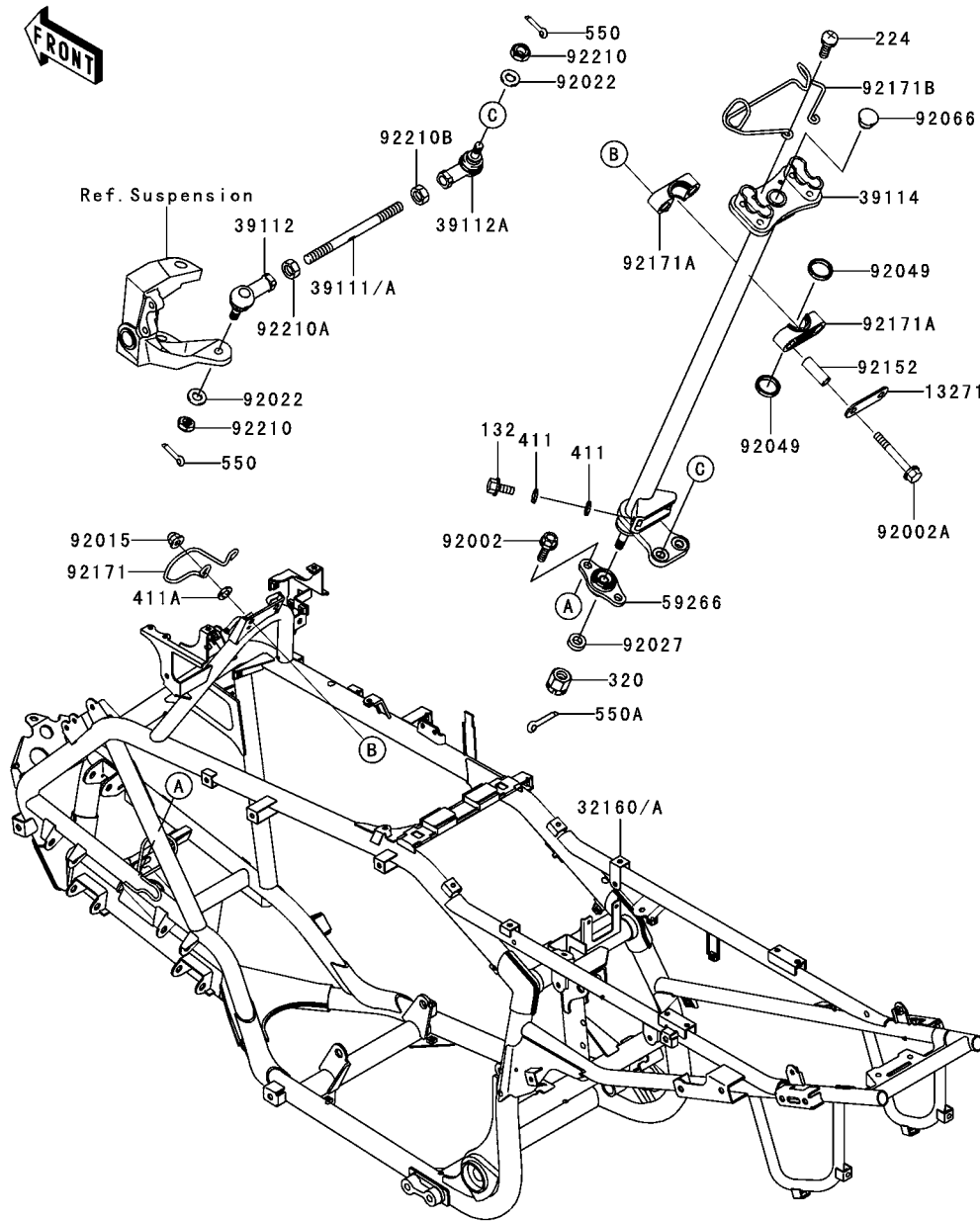

Ref. No.	Part No.	Description	Spec Code	Quantity-KSV700			
				'04	'05		
				A1	A2		
13271	13271-1887	PLATE	1	1			
32160	32160-0028-HN	FRAME-COMP,G.GRAY		1			
32160A	32160-1800-HN	FRAME-COMP,G.GRAY	1				
39111	39111-0010	ROD-TIE			2		
39111A	39111-1180	ROD-TIE	2				
39112	39112-1087	RODEND-TIE,RIGHT HANDED	2	2			
39112A	39112-1088	RODEND-TIE,LEFT HANDED	2	2			
39114	39114-0001	SHAFT-COMP-STRG	1	1			
59266	59266-0001	JOINT-BALL	1	1			
92002	92002-1250	BOLT,8X20	2	2			
92002A	92002-1349	BOLT,FLANGED,8X70	2	2			
92015	92015-1174	NUT,CAP,8MM,BLACK	2	2			
92022	92022-3742	WASHER,10.2X20X1.5	4	4			
92027	92027-1817	COLLAR,10X21.3X7	1	1			
92049	92049-1611	SEAL-OIL,SR25.4X31X3.8	2	2			
92066	92066-1220	PLUG	1	1			
92152	92152-1456	COLLAR,9.1X13.9X39.2	2	2			
92171	92171-0066	CLAMP,CABLE	1	1			
92171A	92171-1542	CLAMP,STEERING SHAFT	2	2			
92171B	92171-1543	CLAMP,CABLE&HARNES	1	1			
92210	92210-1184	NUT,LOCK,10MM	4	4			
92210A	92210-1385	NUT,RIGHT HANDED	2	2			
92210B	92210-1386	NUT,LEFT HANDED	2	2			
132	132J0616	BOLT-FLANGED-SMALL	2	2			
224	224C0614	SCREW-PAN-WP-CROS	2	2			
320	320H1000	NUT-CASTLE	1	1			
411	411B0600	WASHER-PLAIN,6MM	4	4			
411A	411F0800	WASHER-PLAIN,8MM,BLACK	2	2			
550	550D2015	PIN-COTTER,2.0X15	4	4			
550A	550D2518	PIN-COTTER,2.5X18	1	1			

This catalog covers:

'04~'05 KSV700-A1/A2 Chassis

GRID NO.

E-4

This grid covers:

Frame Fittings

F2131

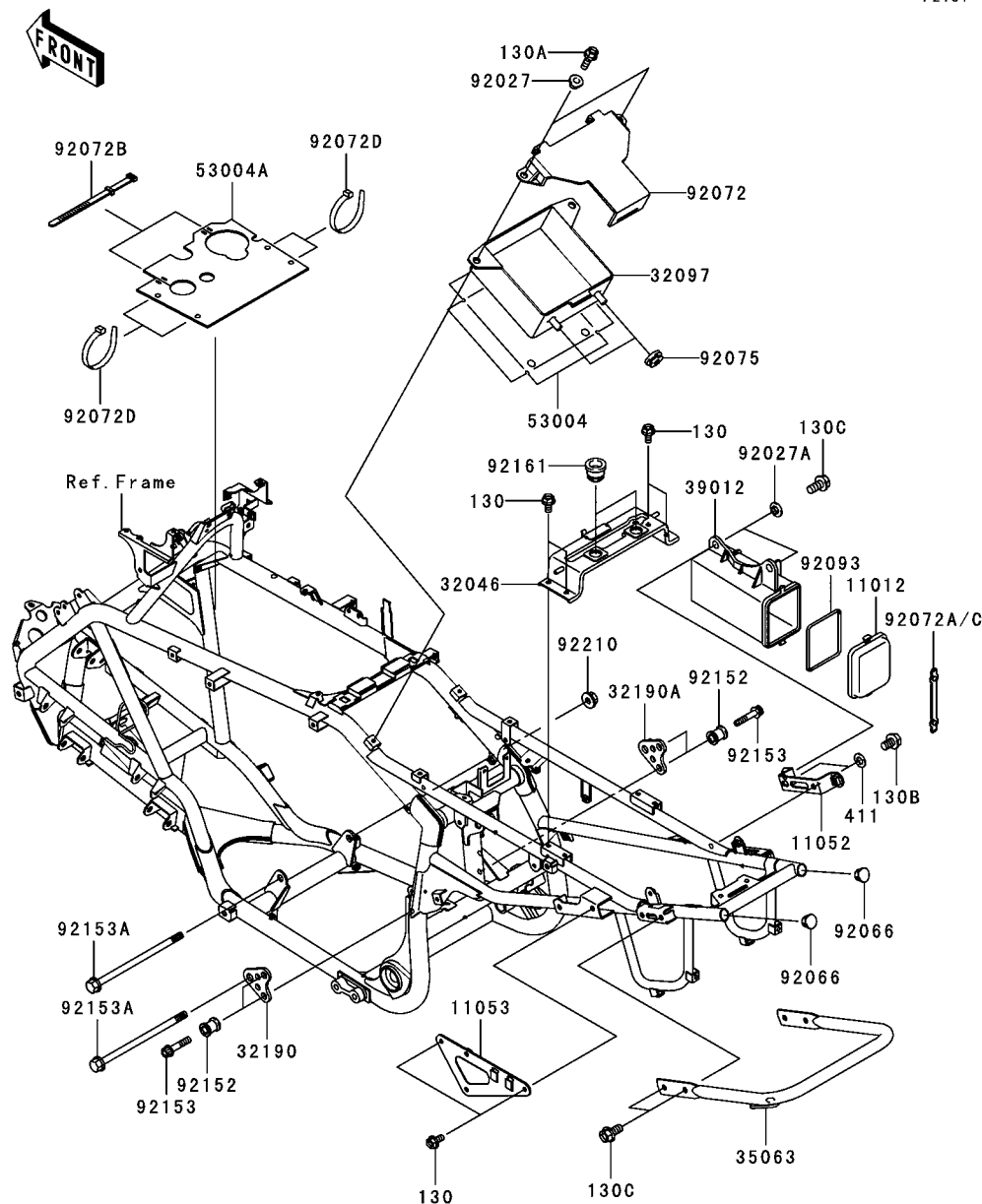

Ref. No.	Part No.	Description	Spec Code	Quantity-KSV700			
				'04	'05	A1	A2
11012	11012-1606	CAP,TOOL CASE		1	1		
11052	11052-1930	BRACKET,TOOL CASE JOINT		1	1		
11053	11053-0301	BRACKET,REGULATOR,LH		1	1		
32046	32046-0006	BRACKET-SEAT		1	1		
32097	32097-0002	CASE-BATTERY		1	1		
32190	32190-1315-HN	BRACKET-ENGINE,RR,UPP,LH,GRAY		1	1		
32190A	32190-1316-HN	BRACKET-ENGINE,RR,UPP,RH,GRAY		1	1		
35063	35063-0033-HN	STAY,GLOVE BAR,G.GRAY		1	1		
39012	39012-1055	CASE-STORAGE		1	1		
53004	53004-0002	MAT,BATTERY CASE		1	1		
53004A	53004-0009	MAT,WATER PROTECT		1	1		
92027	92027-1166	COLLAR		2	2		
92027A	92027-1354	COLLAR		2	2		
92066	92066-1220	PLUG		2	2		
92072	92072-0006	BAND,BATTERY		1	1		
92072A	92072-0032	BAND,TOOL CASE CAP			1		
92072B	92072-030	BAND,L=123		2	2		
92072C	92072-1226	BAND,TOOL CASE CAP		1			
92072D	92072-1239	BAND,L=188		4	4		
92075	92075-1787	DAMPER		2	2		
92093	92093-1247	SEAL,TOOL CASE CAP		1	1		
92152	92152-0061	COLLAR,L=25		4	4		
92153	92153-0408	BOLT,SOCKET,10X45		4	4		
92153A	92153-1272	BOLT,FLANGED,12X190		2	2		
92161	92161-0048	DAMPER		2	2		
92210	92210-1150	NUT,LOCK,FLANGED,12MM		1	1		
130	130J0612	BOLT-FLANGED		6	6		
130A	130J0616	BOLT-FLANGED,6X16,BLACK		2	2		
130B	130J0812	BOLT-FLANGED		2	2		
130C	130J0816	BOLT-FLANGED,8X16,BLACK		6	6		
411	411F0800	WASHER-PLAIN,8MM,BLACK		2	2		

This catalog covers:

'04~'05 KSV700-A1/A2 Chassis

GRID NO.

E-5

This grid covers:

Swingarm

F2141

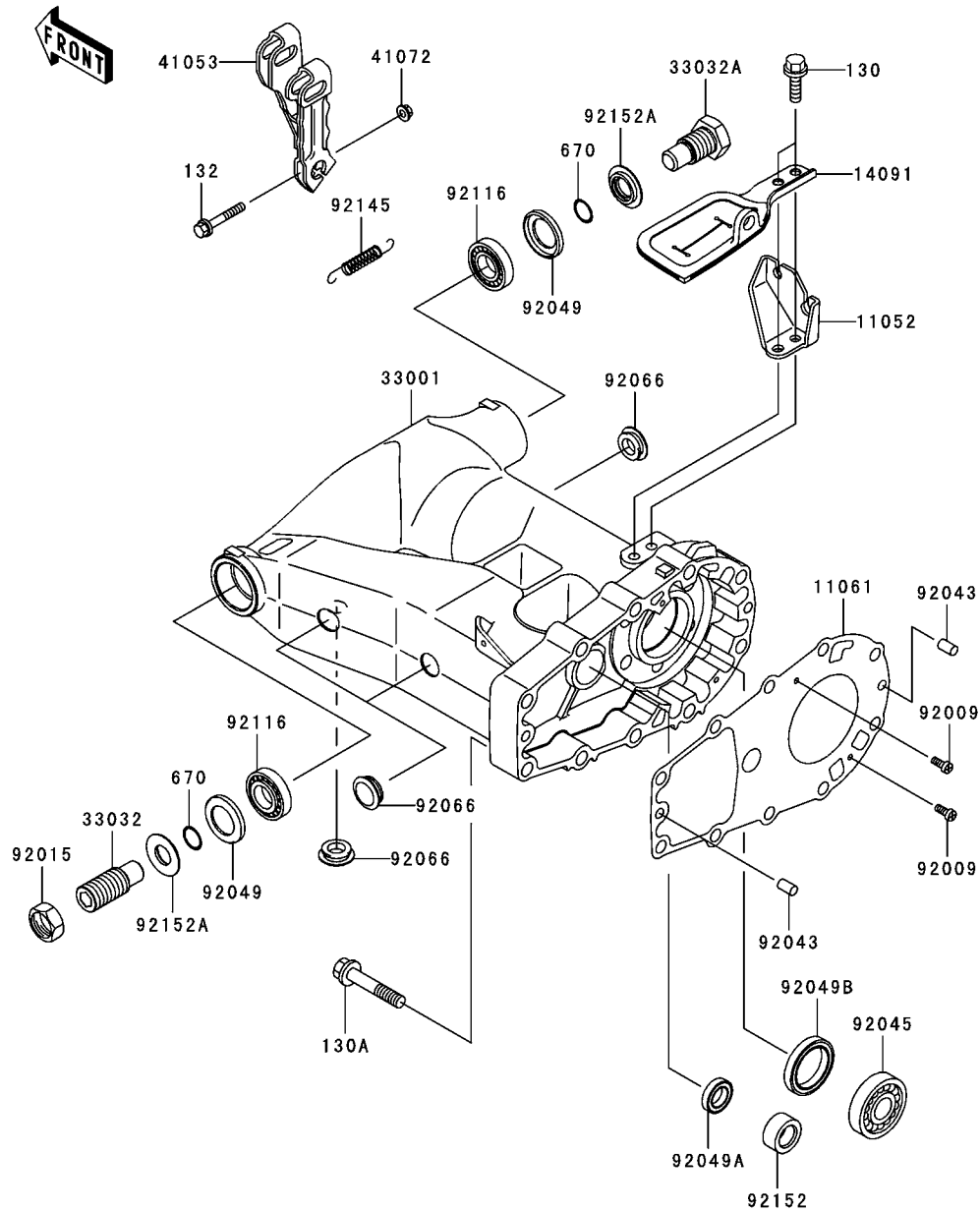

Ref. No.	Part No.	Description	Spec Code	Quantity-KSV700			
				'04	'05		
				A1	A2		
11052	11052-1888	BRACKET,CABLE STOPPER	1	1			
11061	11061-1065	GASKET,SWING ARM	1	1			
14091	14091-1425	COVER,BRAKE	1	1			
33001	33001-1585	ARM-COMP-SWING	1	1			
33032	33032-1197	SHAFT-SWING ARM,LEFT SIDE	1	1			
33032A	33032-1200	SHAFT-SWING ARM,RIGHT SIDE	1	1			
41053	41053-1099	LEVER-BRAKE CAM	1	1			
41072	41072-007	NUT,6MM	1	1			
92009	92009-1936	SCREW,4X10	2	2			
92015	92015-1229	NUT,22MM	1	1			
92043	92043-1567	PIN,8X14	2	2			
92045	92045-1427	BEARING-BALL,TMBO/28C3	1	1			
92049	92049-1030	SEAL-OIL,26406	2	2			
92049A	92049-1537	SEAL-OIL,TC17X28X6	1	1			
92049B	92049-1538	SEAL-OIL,HTC35X48X7	1	1			
92066	92066-1534	PLUG	4	4			
92116	92116-1001	BEARING-ROLLER,4T30203E1	2	2			
92145	92145-1313	SPRING,BRAKE LEVER RETURN	1	1			
92152	92152-1240	COLLAR	1	1			
92152A	92152-1356	COLLAR	2	2			
130	130J0822	BOLT-FLANGED	2	2			
130A	130P1055	BOLT-FLANGED	10	10			
132	132G0640	BOLT-FLANGED-SMALL	1	1			
670	670B2016	O RING,16MM	2	2			

This catalog covers:

'04~'05 KSV700-A1/A2 Chassis

GRID NO.

E-6

This grid covers:

Suspension

F2150

Ref. No.	Part No.	Description	Spec Code	Quantity-KSV700			
				'04	'05		
				A1	A2		

13107	13107-1507	SHAFT, KNUCKLE	2	2		
39007	39007-1307-HN	ARM-SUSP,LH,UPP,G.GRAY	1	1		
39007A	39007-1309-HN	ARM-SUSP,RH,UPP,G.GRAY	1	1		
39007B	39007-1311-HN	ARM-SUSP,LH,LWR,G.GRAY	1	1		
39007C	39007-1312-HN	ARM-SUSP,RH,LWR,G.GRAY	1	1		
39186	39186-0003	KNUCKLE,LH	1	1		
39186A	39186-0004	KNUCKLE,RH	1	1		
42036	42036-1376	SLEEVE	4	4		
59266	59266-1011	JOINT-BALL	4	4		
59266A	59266-1139	JOINT-BALL	4	4		
92015	92015-1428	NUT,FLANGED,10MM	8	8		
92022	92022-1065	WASHER,12.3X22X1.6	2	2		
92033	92033-1262	RING-SNAP,C-TYPE,32MM	4	4		
92046	92046-1046	BEARING-NEEDLE	4	4		
92049	92049-1223	SEAL-OIL,MHA17245.7F	16	16		
92150	92150-1384	BOLT,FLANGED,10X63	8	8		
92152	92152-1455	COLLAR,10X17X14.5	8	8		
92171	92171-0094	CLAMP,BRAKE HOSE	1	1		
92171A	92171-0095	CLAMP,BRAKE HOSE	1	1		
321	321H1200	NUT-CASTLE,12MM	4	4		
481	481J2400	CIRCLIP	8	8		
550	550D3025	PIN-COTTER,3.0X25	4	4		

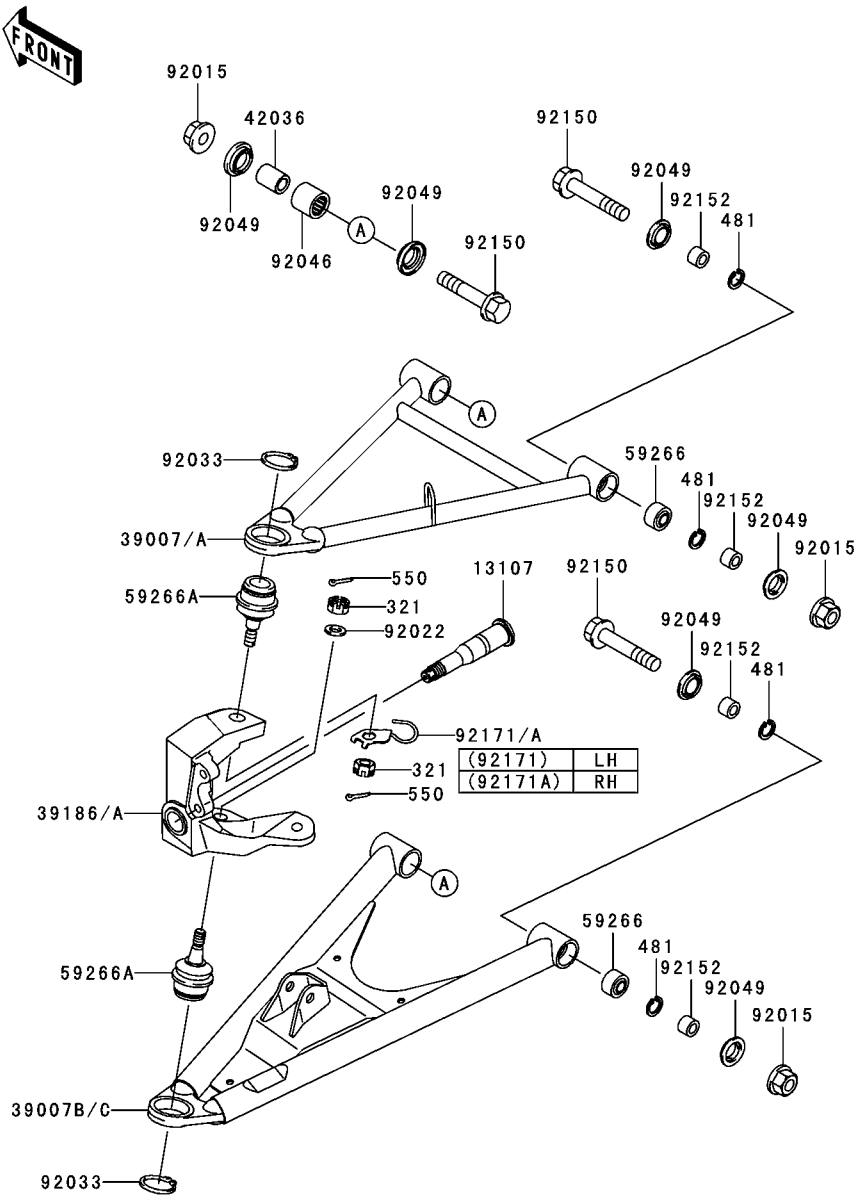

This catalog covers:

'04~'05 KSV700-A1/A2 Chassis

GRID NO.

E-7

This grid covers:

Footrests

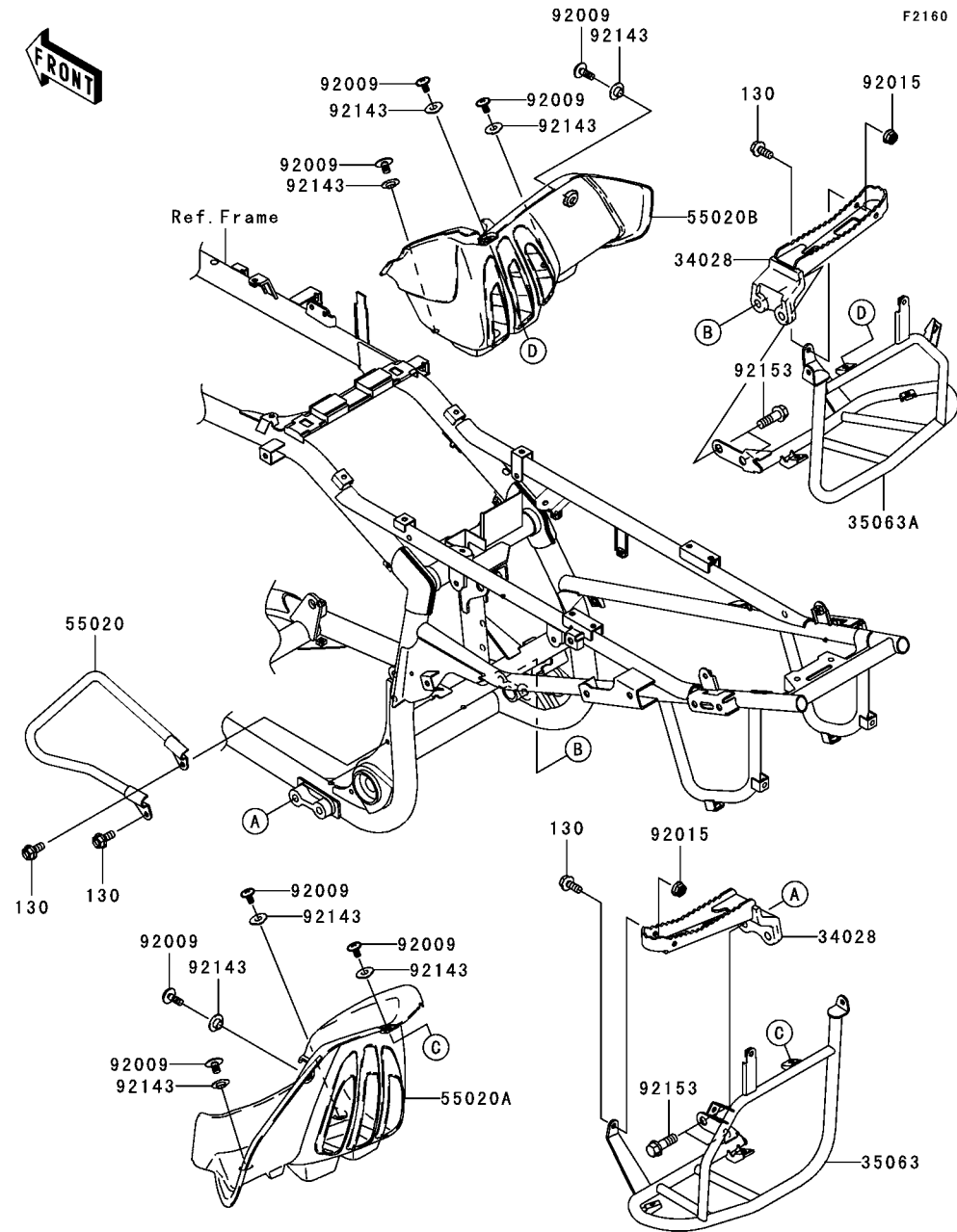

Ref. No.	Part No.	Description	Quantity-KSV700			
			'04	'05		
			A1	A2		
34028	34028-1535-HN	STEP,G.GRAY	2	2		
35063	35063-0027	STAY,STEP,LH	1	1		
35063A	35063-0028	STAY,STEP,RH	1	1		
55020	55020-0033	GUARD,LEFT STEP	1	1		
55020A	55020-1799-6Z	GUARD,STEP,LH,F.BLACK	1	1		
55020B	55020-1800-6Z	GUARD,STEP,RH,F.BLACK	1	1		
92009	92009-1621	SCREW,6X16	8	8		
92015	92015-1603	NUT,LOCK,FLANGED,6MM	2	2		
92143	92143-1087	COLLAR	8	8		
92153	92153-0427	BOLT,FLANGED,10X30	4	4		
130	130J0614	BOLT-FLANGED,6X14,BLACK	4	4		

This catalog covers:

'04~'05 KSV700-A1/A2 Chassis

GRID NO.

E-8

This grid covers:

Front Fender(s)

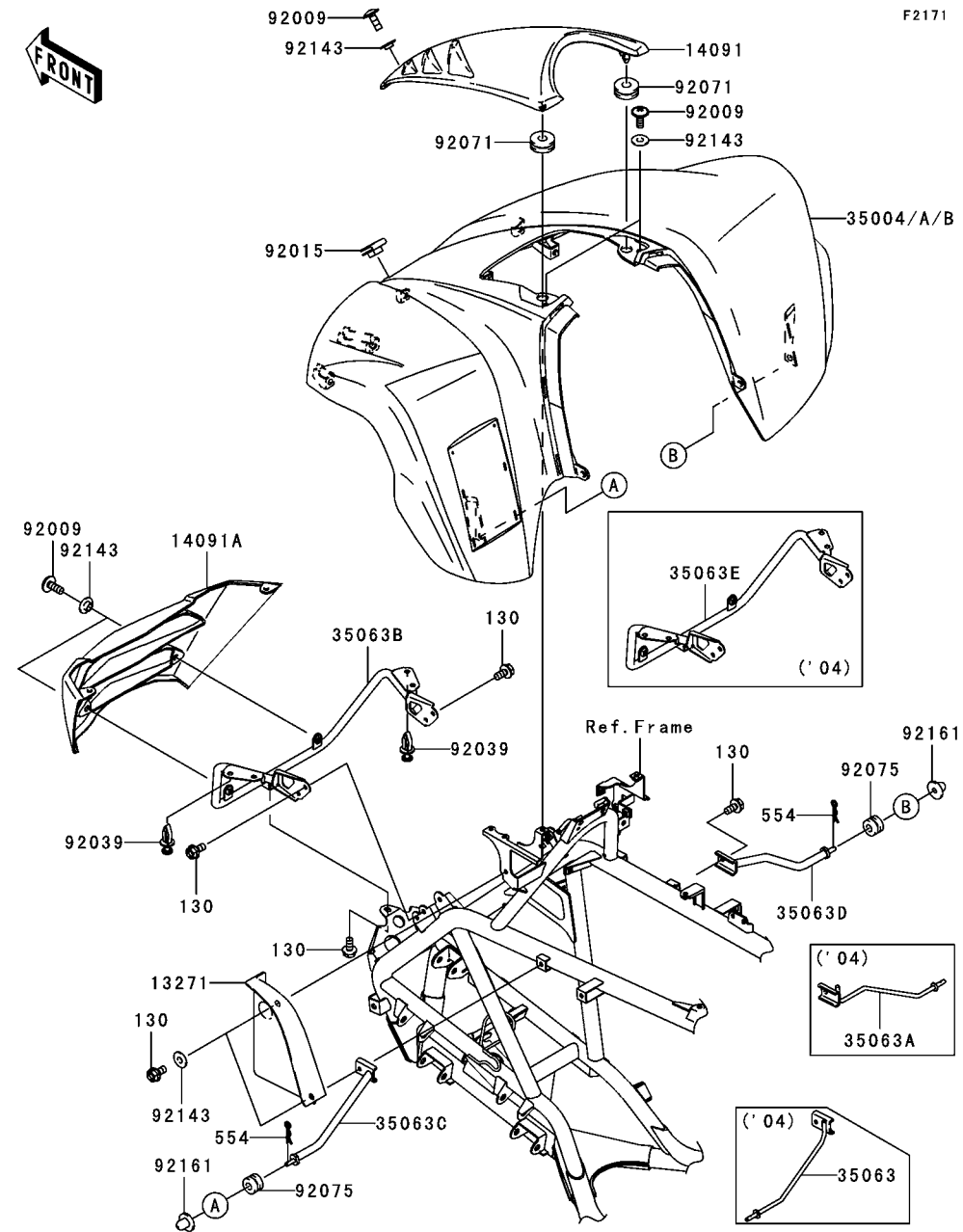

F2171

Ref. No.	Part No.	Description	Spec Code	Quantity-KSV700			
				'04	'05		
				A1	A2		
13271	13271-0058	PLATE,FRONT FENDER	1	1			
14091	14091-1511-6D	COVER,MAINTENANCE,BLACK	1	1			
14091A	14091-1524-6Z	COVER,FRONT GRILL,F.BLACK	1	1			
35004	35004-0014-268	FENDER-FRONT,B.ORANGE					
		L-----AS	1				
		L-----EU		1			
35004A	35004-0014-290	FENDER-FRONT,L.GREEN		1			
35004B	35004-0014-6W	FENDER-FRONT,L.GREEN		1			
35063	35063-0053	STAY,FRONT FENDER,LH	1				
35063A	35063-0064	STAY,FRONT FENDER,RH	1				
35063B	35063-0067	STAY,FRONT GRILL			1		
35063C	35063-0139	STAY,FRONT FENDER,LH			1		
35063D	35063-0140	STAY,FRONT FENDER,RH			1		
35063E	35063-1253	STAY,FRONT GRILL	1				
92009	92009-1621	SCREW,6X16	5	5			
92015	92015-1678	NUT,CLAMP,6MM	1	1			
92039	92039-1229	RIVET	2	2			
92071	92071-1131	GROMMET	2	2			
92075	92075-1435	DAMPER	2	2			
92143	92143-1087	COLLAR	7	7			
92161	92161-1160	DAMPER	2	2			
130	130J0612	BOLT-FLANGED	8	8			
554	554A0600	PIN-SNAP	2	2			

This catalog covers:

'04~'05 KSV700-A1/A2 Chassis

GRID NO.

E-9

This grid covers:

Rear Fender(s)

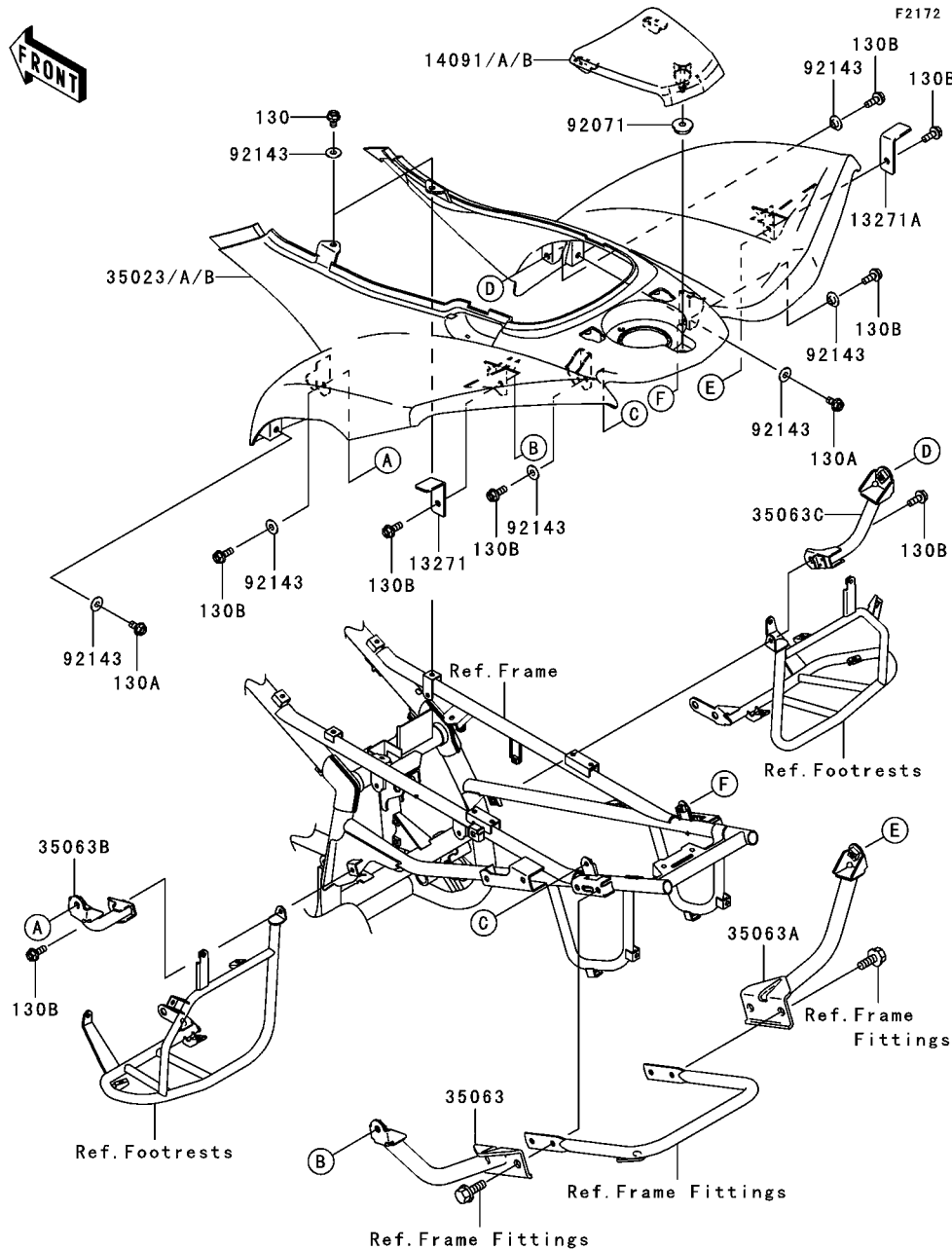

Ref. No.	Part No.	Description	Spec Code	Quantity-KSV700	
				'04	'05
				A1	A2
13271	13271-0126	PLATE,RR FENDER,LH	1	1	
13271A	13271-0127	PLATE,RR FENDER,RH	1	1	
14091	14091-0096-268	COVER,TANK CAP,B.ORANGE			
		L-----AS	1		
		L-----EU		1	
14091A	14091-0096-290	COVER,TANK CAP,L.GREEN		1	
14091B	14091-0096-6W	COVER,TANK CAP,L.GREEN	1		
35023	35023-0010-268	FENDER-REAR,B.ORANGE			
		L-----AS	1		
		L-----EU		1	
35023A	35023-0010-290	FENDER-REAR,L.GREEN		1	
35023B	35023-0010-6W	FENDER-REAR,L.GREEN	1		
35063	35063-0042	STAY,REAR FENDER,LH	1	1	
35063A	35063-0043	STAY,REAR FENDER,RH	1	1	
35063B	35063-0044	STAY,REAR FENDER,LH	1	1	
35063C	35063-0045	STAY,REAR FENDER,RH	1	1	
92071	92071-0008	GROMMET	1	1	
92143	92143-1087	COLLAR	8	8	
130	130J0610	BOLT-FLANGED	2	2	
130A	130J0612	BOLT-FLANGED	2	2	
130B	130J0616	BOLT-FLANGED,6X16,BLACK	8	8	

This catalog covers:

'04~'05 KSV700-A1/A2 Chassis

GRID NO.

E-10

This grid covers:

Tires

F2210

Ref. No.	Part No.	Description	Spec Code	Quantity-KSV700			
				'04	'05		
				A1	A2		
16126	16126-4001	VALVE		4	4		
41009	41009-0006	TIRE,FR,AT22X7-10		2			
41009A	41009-0007	TIRE,RR,AT22X11-10		2			
41009B	41009-0033	TIRE,FR,AT22X7-10			2		
41009C	41009-0034	TIRE,RR,AT22X11-10			2		
41025	41025-0002	RIM,FR,10X5.5AT		2	2		
41025A	41025-0003	RIM,RR,10X8.5AT		2	2		
92200	92200-1595	WASHER,10.5X25X1.6		16	16		
92210	92210-1325	NUT,FLANGED,10MM		16	16		

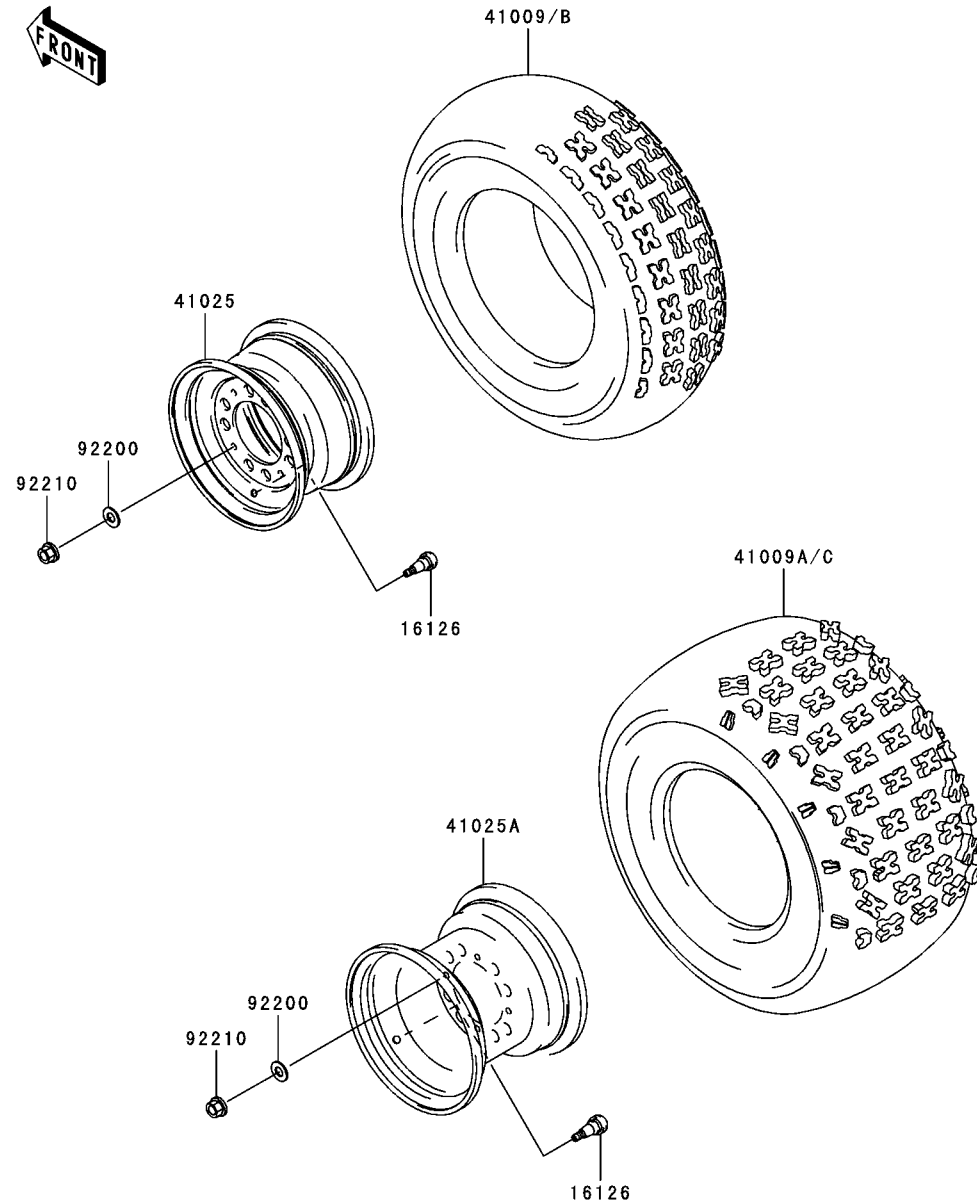

This catalog covers:

'04~'05 KSV700-A1/A2 Chassis

GRID NO.

E-11

This grid covers:

Front Hub

F2230

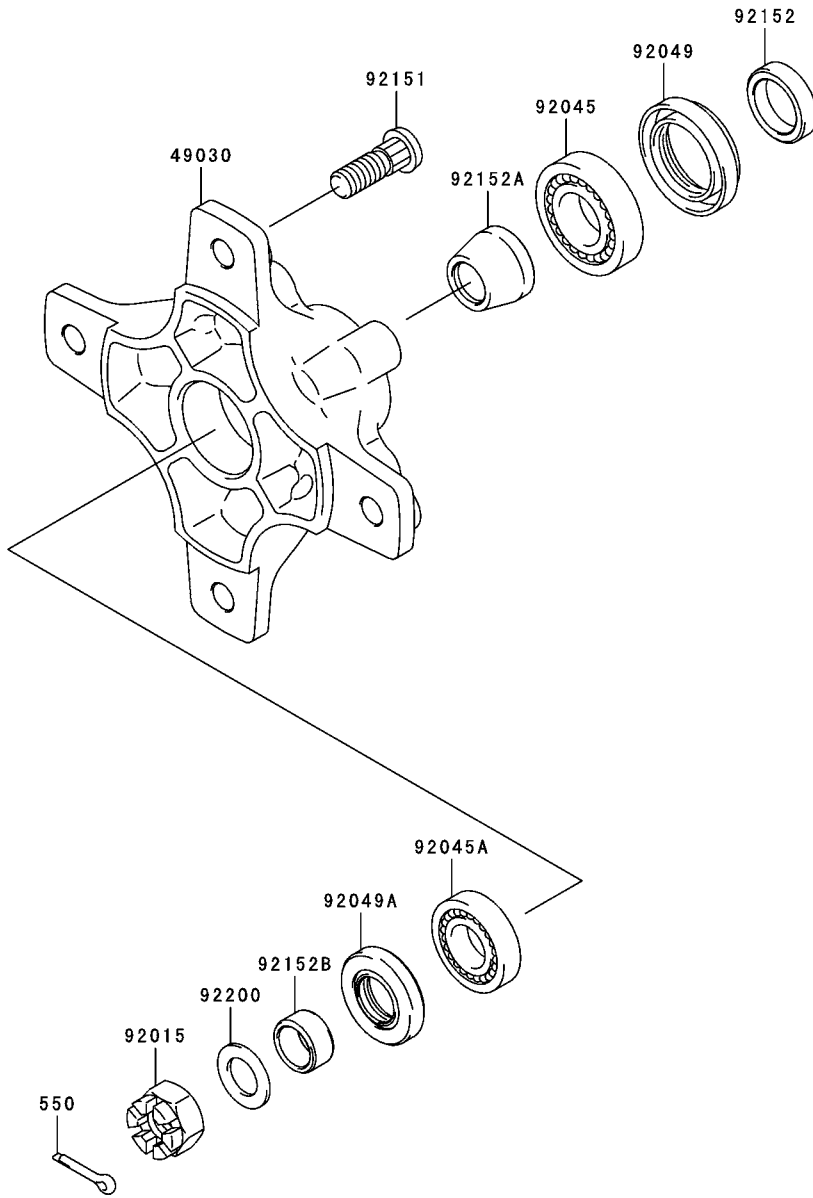

Ref. No.	Part No.	Description	Spec Code	Quantity-KSV700			
				'04	'05		
				A1	A2		
49030	49030-1142	HUB,FR	2	2			
92015	92015-1765	NUT,CASTLE,14MM	2	2			
92045	92045-3705	BEARING-BALL,60042RD	2	2			
92045A	92045-3721	BEARING-BALL,62022RD	2	2			
92049	92049-1612	SEAL-OIL,MT028N1	2	2			
92049A	92049-1613	SEAL-OIL,MHSA20X35X7	2	2			
92151	92151-1392	BOLT,10X29.5	8	8			
92152	92152-1461	COLLAR,21.2X28X7	2	2			
92152A	92152-1462	COLLAR	2	2			
92152B	92152-1463	COLLAR,15.2X20X10	2	2			
92200	92200-1171	WASHER,14.5X24X1.6	2	2			
550	550D3030	PIN-COTTER,3.0X30	2	2			

This catalog covers:

'04~'05 KSV700-A1/A2 Chassis

GRID NO.

E-12

This grid covers:

Rear Hub



F2240

Ref. No.	Part No.	Description	Spec Code	Quantity-KSV700			
				'04	'05		
				A1	A2		
49030	49030-1140	HUB,RR	2	2			
92151	92151-1392	BOLT,10X29.5	8	8			
92210	92210-1381	NUT,CASTLE,20MM	2	2			
550	550D4025	PIN-COTTER,4.0X25	2	2			

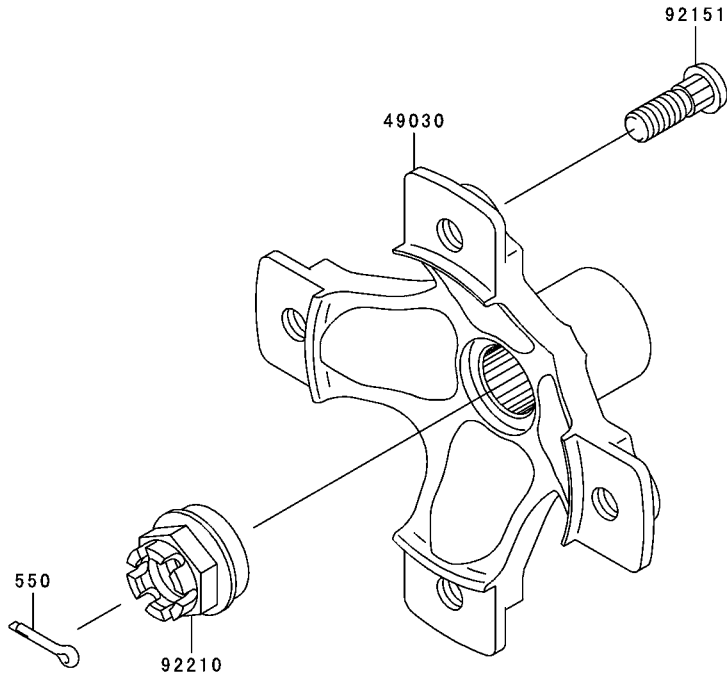

This catalog covers:

'04~'05 KSV700-A1/A2 Chassis

GRID NO.

E-13

This grid covers:

Brake Pedal

F2260

Ref. No.	Part No.	Description	Spec Code	Quantity-KSV700			
				'04	'05		
				A1	A2		
13168	13168-0014	LEVER	1	1			
27010	27010-1494	SWITCH,BRAKE	1	1			
41055	41055-003	PIN	1	1			
43001	43001-0011-HN	LEVER-BRAKE,PEDAL,G.GRAY	1	1			
92015	92015-1410	NUT,6MM	1	1			
92022	92022-1582	WASHER,8.5X16X1.2	1	1			
92022A	92022-1690	WASHER,6.5X24X2	1	1			
92022B	92022-1943	WASHER,SPRING,T=0.3	1	1			
92043	92043-1013	PIN,8X16	1	1			
92081	92081-1565	SPRING,BRAKE SWITCH	1	1			
92145	92145-1534	SPRING,BRAKE PEDAL RETURN	1	1			
130	130G0620	BOLT-FLANGED,6X20	1	1			
130A	130J0612	BOLT-FLANGED	1	1			
410	410B0600	WASHER-PLAIN-SMALL,6MM	1	1			
550	550D1210	PIN-COTTER,1.2X10	1	1			
550A	550D2015	PIN-COTTER,2.0X15	1	1			

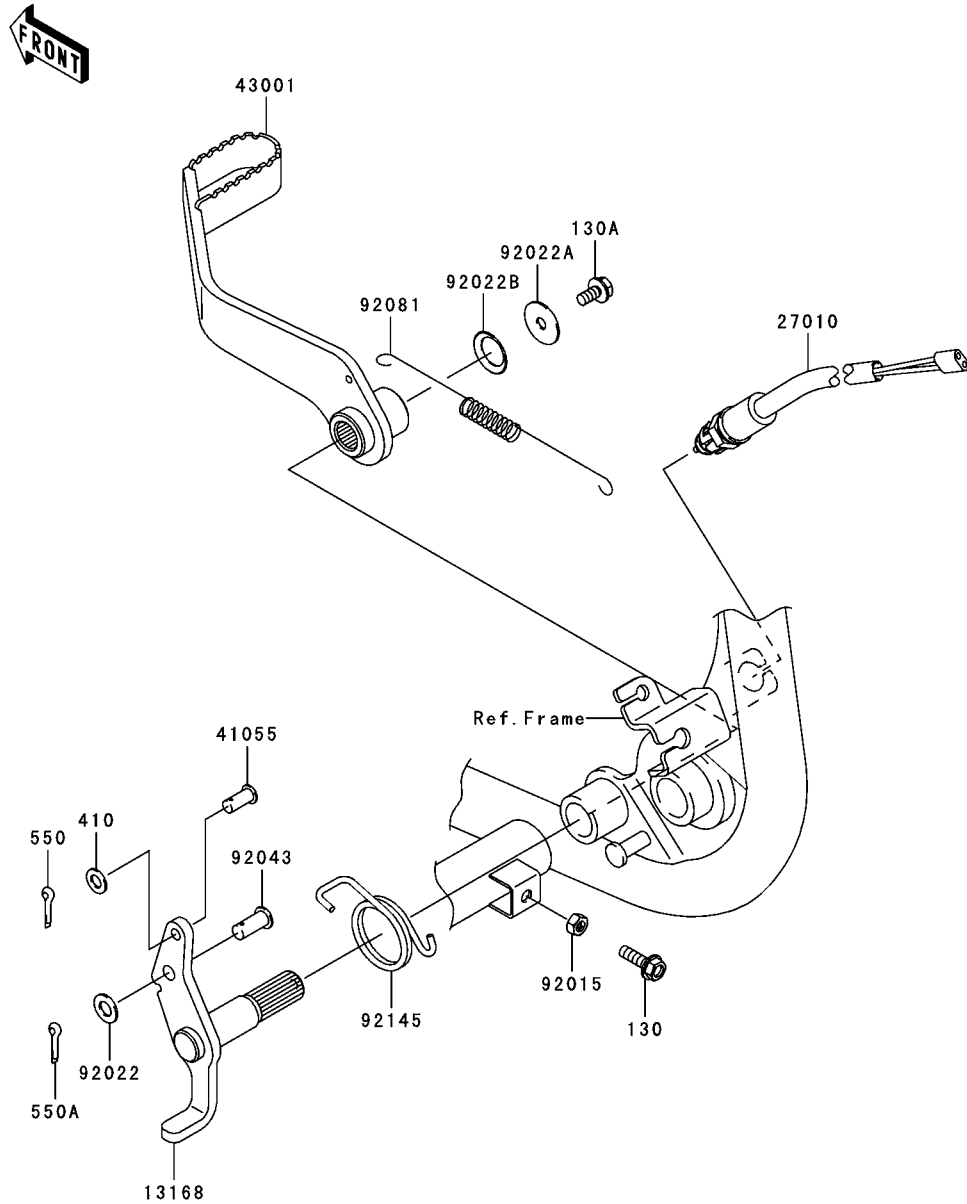

This catalog covers:

'04~'05 KSV700-A1/A2 Chassis

GRID NO.

E-14

This grid covers:

Shock Absorber(s)

F2280

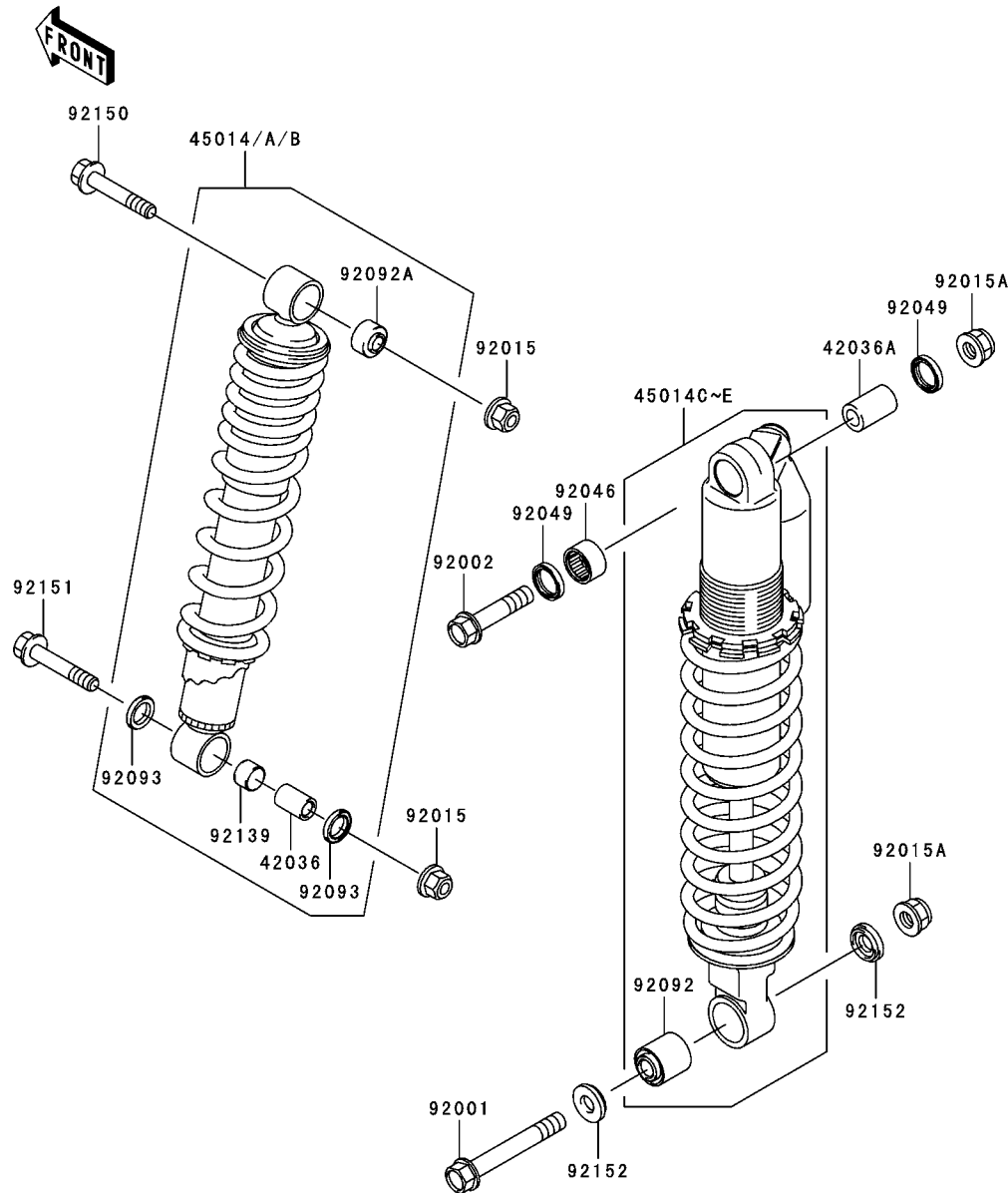

Ref. No.	Part No.	Description	Spec Code	Quantity-KSV700			
				'04	'05		
				A1	A2		
42036	42036-0012	SLEEVE		2	2		
42036A	42036-1378	SLEEVE,12X20X32		1	1		
45014	45014-0004-CC	SHOCKABSORBER,FR,L.GREEN		2			
45014A	45014-0004-EH	SHOCKABSORBER,FR,P.WHITE					
		L-----AS		2			
		L-----EU			2		
45014B	45014-0004-710	SHOCKABSORBER,FR,L.GREEN			2		
45014C	45014-0005-CC	SHOCKABSORBER,RR,L.GREEN		1			
45014D	45014-0005-EH	SHOCKABSORBER,RR,P.WHITE					
		L-----AS		1			
		L-----EU			1		
45014E	45014-0005-710	SHOCKABSORBER,RR,L.GREEN		1	1		
92001	92001-1693	BOLT,FLANGED,12X88		1	1		
92002	92002-1840	BOLT,FLANGED,12X55		1	1		
92015	92015-1597	NUT,LOCK,10MM		4	4		
92015A	92015-1617	NUT,FLANGED,LOCK,12MM		2	2		
92046	92046-1239	BEARING-NEEDLE		1	1		
92049	92049-1108	SEAL-OIL,GD20X26X4		2	2		
92092	92092-1054	BUSHING-RUBBER,SHOCKABSORBER		1	1		
92092A	92092-1079	BUSHING-RUBBER		2	2		
92093	92093-0010	SEAL		4	4		
92139	92139-0042	BUSHING		2	2		
92150	92150-1719	BOLT,FLANGED,10X51		2	2		
92151	92151-1413	BOLT,FLANGED,10X45		2	2		
92152	92152-1293	COLLAR		2	2		

This catalog covers:

'04~'05 KSV700-A1/A2 Chassis

GRID NO.

F-3

This grid covers:

Front Master Cylinder

F2291

Ref. No.	Part No.	Description	Spec Code	Quantity-KSV700			
				'04	'05		
				A1	A2		
27010	27010-1170	SWITCH,BRAKE		1	1		
43015	43015-1646	CYLINDER-ASSY-MASTER,FR		1	1		
43020	43020-1056	PISTON-COMP-BRAKE,FR		1	1		
43022	43022-1010	STOPPER-BRAKE,PISTON		1	1		
43026	43026-1074	CAP-BRAKE		1	1		
43028	43028-1061	DIAPHRAGM		1	1		
43034	43034-1016	HOLDER-BRAKE,MASTER CYLINDER		1	1		
43067	43067-001	WASHER,10.5X15X1.5		6	6		
43095	43095-0030	HOSE-BRAKE,FR		1	1		
46092	46092-1208	LEVER-GRIP,FRONT BRAKE		1	1		
49006	49006-1040	BOOT,DUST		1	1		
49006A	49006-1338	BOOT,RH		1	1		
49016	49016-1044	COVER-SEAL,MASTER CYLINDER		1	1		
92001	92001-1728	BOLT,FRONT BRAKE LEVER		1	1		
92002	92002-1323	BOLT,SCREW,4X12		1	1		
92002A	92002-1888	BOLT,OIL,L=23		3			
92002B	92002-1894	BOLT		2	2		
92009	92009-1458	SCREW,4MM		2	2		
92015	92015-1233	NUT,FLANGED,6MM,BLACK		1	1		
92153	92153-0627	BOLT,OIL,L=23			3		
132	132J0625	BOLT-FLANGED-SMALL		1	1		

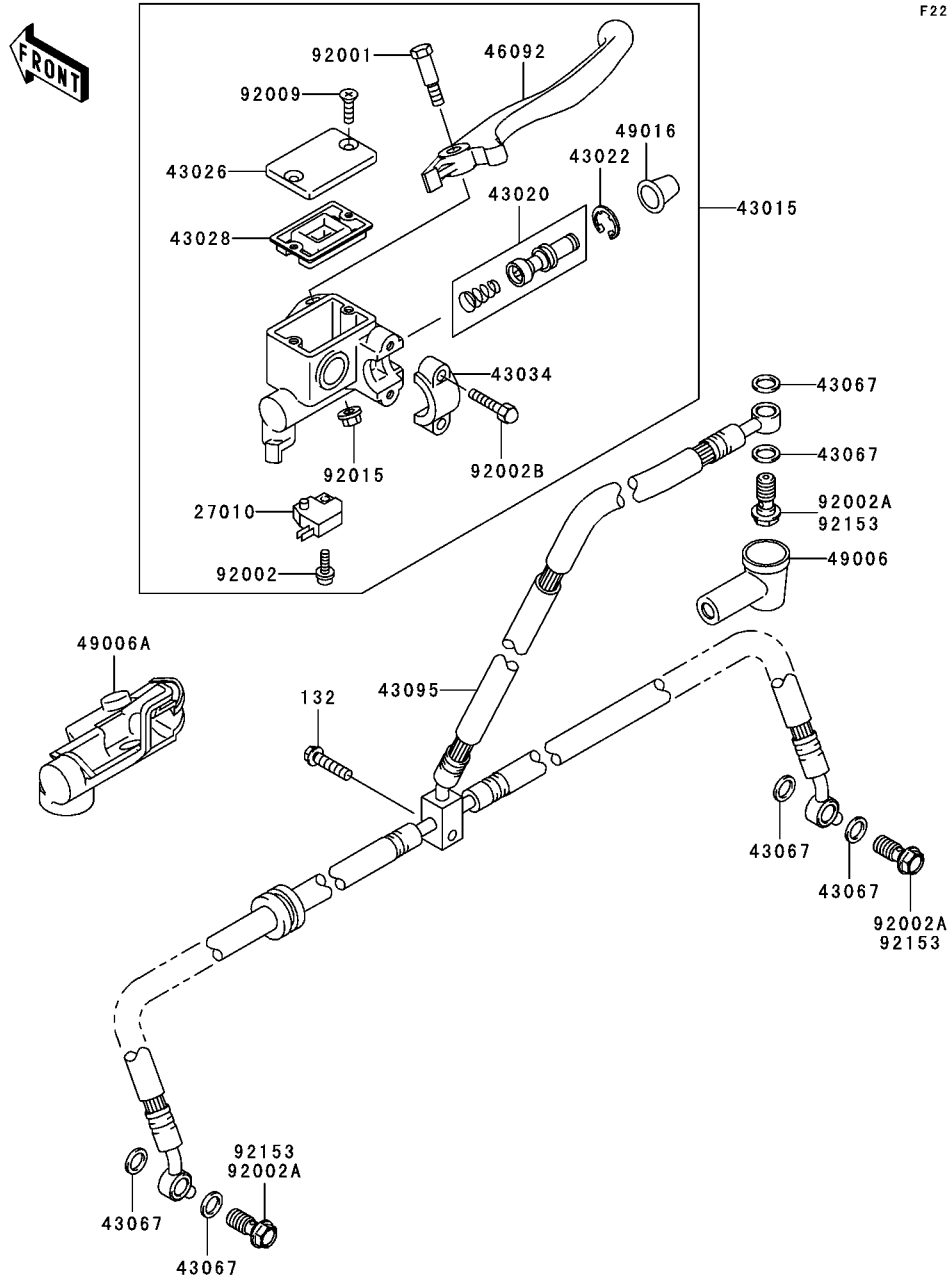

This catalog covers:

'04~'05 KSV700-A1/A2 Chassis

GRID NO.

F-4

This grid covers:

Front Brake

F2292

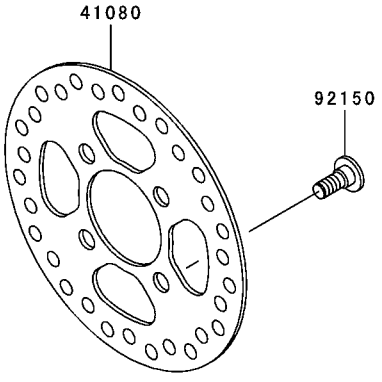
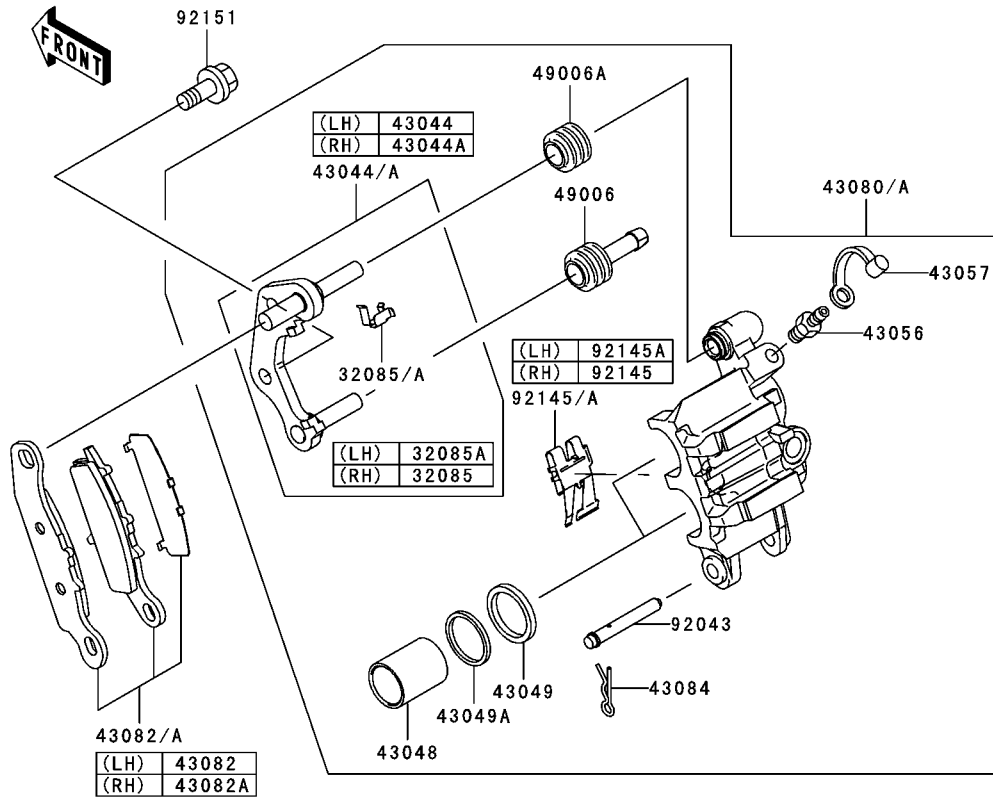

Ref. No.	Part No.	Description	Spec Code	Quantity-KSV700			
				'04	'05		
				A1	A2		
32085	32085-1437	STOPPER	1	1			
32085A	32085-1517	STOPPER	1	1			
41080	41080-1534	DISC,FR	2	2			
43044	43044-1130	HOLDER-COMP-CALIPER,FR,LH	1	1			
43044A	43044-1131	HOLDER-COMP-CALIPER,FR,RH	1	1			
43048	43048-1083	PISTON-CALIPER	4	4			
43049	43049-1059	PACKING,PISTON	4	4			
43049A	43049-1090	PACKING,PISTON SEAL	4	4			
43056	43056-1054	BREATHER-BRAKE	2	2			
43057	43057-003	CAP-BREATHER	2	2			
43080	43080-5081-DJ	CALIPER-SUB-ASSY,FR,RH,BLACK	1	1			
43080A	43080-5082-DJ	CALIPER-SUB-ASSY,FR,LH,BLACK	1	1			
43082	43082-1255	PAD-ASSY-BRAKE	1	1			
43082A	43082-1273	PAD-ASSY-BRAKE	1	1			
43084	43084-003	CLAMP,PAD	2	2			
49006	49006-1054	BOOT,CALIPER	2	2			
49006A	49006-1055	BOOT,CALIPER	2	2			
92043	92043-1356	PIN,PAD	2	2			
92145	92145-1260	SPRING,PAD	1	1			
92145A	92145-1354	SPRING,PAD	1	1			
92150	92150-1771	BOLT,SOCKET,8X30	8	8			
92151	92151-1793	BOLT,FLANGED,8X19	4	4			

This catalog covers:

'04~'05 KSV700-A1/A2 Chassis

GRID NO.

F-5

This grid covers:

Handlebar(1/2)

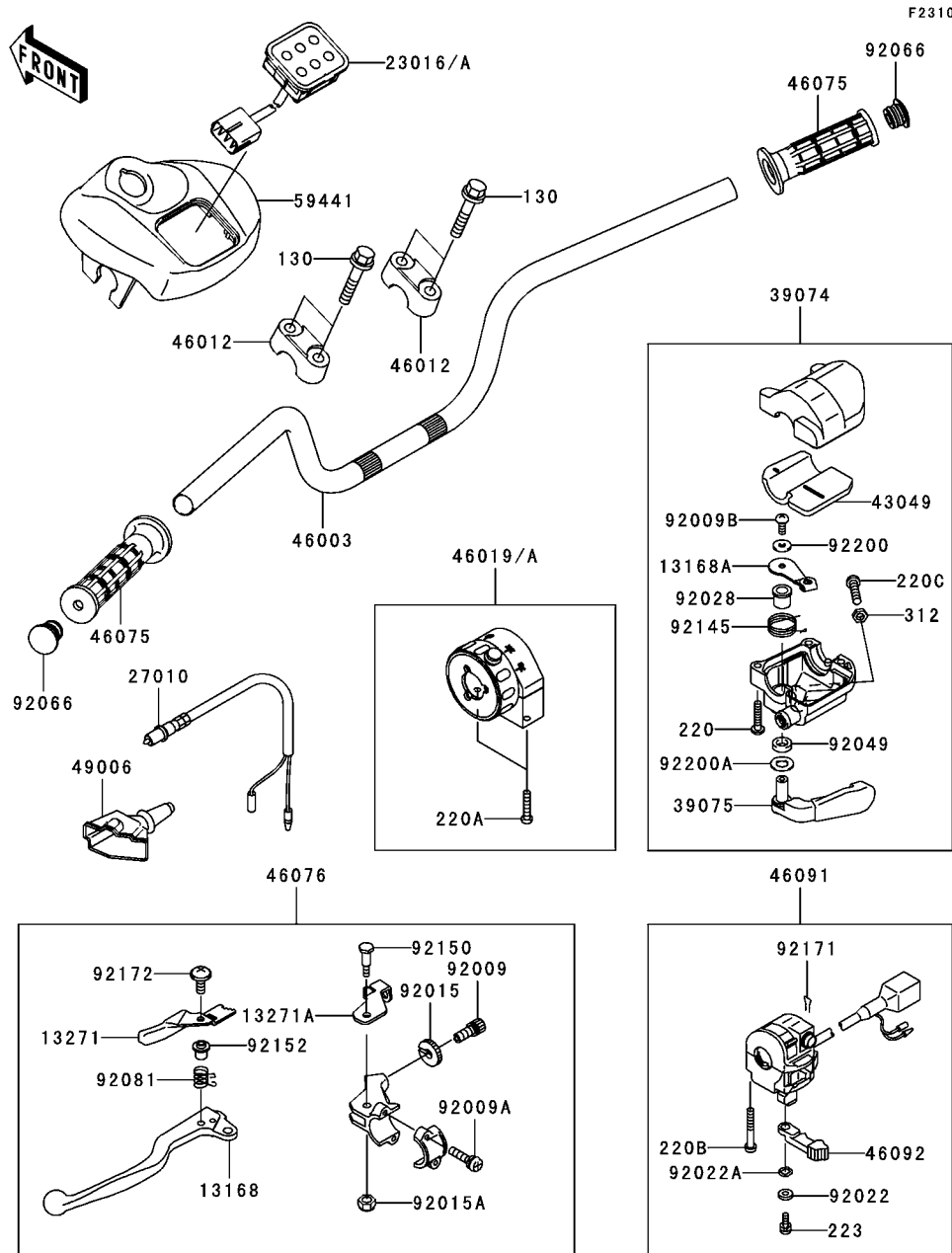

Ref. No.	Part No.	Description	Spec Code	Quantity-KSV700			
				'04	'05		
				A1	A2		
13168	13168-0002	LEVER,LH		1			
13168A	13168-1715	LEVER		1			1
13271	13271-0011	PLATE,LEVER LOCK		1			1
13271A	13271-1259	PLATE,LOCK		1			1
23016	23016-0001	LAMP-ASSY		1			
23016A	23016-0002	LAMP-ASSY					1
27010	27010-1294	SWITCH,BRAKE		1			1
39074	39074-0001	LEVER-ASSY-THROTTLE		1			1
39075	39075-1062	LEVER-THROTTLE		1			1
43049	43049-1088	PACKING		1			1
46003	46003-0001-HN	HANDLE,G.GRAY		1			1
46012	46012-1168	HOLDER-HANDLE		2			2
46019	46019-0006	GRIP-ASSY,SHIFT CONTROL					1
46019A	46019-1122	GRIP-ASSY,SHIFT CONTROL		1			
46075	46075-1210	GRIP		2			2
46076	46076-1258	LEVER-ASSY-GRIP,LH		1			1
46091	46091-1848	HOUSING-ASSY-CONTROL,LH		1			1
46092	46092-1217	LEVER-GRIP,CHOKE		1			1
49006	49006-1261	BOOT		1			1
59441	59441-1173-6D	COVER-HANDLE,BLACK		1			1
92009	92009-1435	SCREW,CABLE ADJUST,8MM		1			1
92009A	92009-1841	SCREW,6X20		2			2
92009B	92009-1959	SCREW		1			1
92015	92015-1596	NUT,CABLE ADJUST LOCK,8MM		1			1
92015A	92015-1829	NUT		1			1
92022	92022-1837	WASHER,5MM		1			1
92022A	92022-1838	WASHER,WAVE,5MM		1			1
92028	92028-1986	BUSHING		1			1
92049	92049-1578	SEAL-OIL		1			1
92066	92066-1550	PLUG		2			2
92081	92081-1358	SPRING,LOCK RETURN		1			1
92145	92145-1392	SPRING		1			1
92150	92150-1420	BOLT		1			1
92152	92152-1176	COLLAR		1			1
92171	92171-1095	CLAMP,CLIP		1			1
92172	92172-0078	SCREW,5X20		1			1
92200	92200-1558	WASHER		1			1
92200A	92200-1559	WASHER		1			1
130	130P0860	BOLT-FLANGED		4			4
220	220C0520	SCREW-PAN-CROS		3			3
220A	220C0525	SCREW-PAN-CROS		2			2
220B	220C0535	SCREW-PAN-CROS		2			2

This catalog covers:

'04~'05 KSV700-A1/A2 Chassis

GRID NO.

F-6

This grid covers:

Handlebar(2/2)

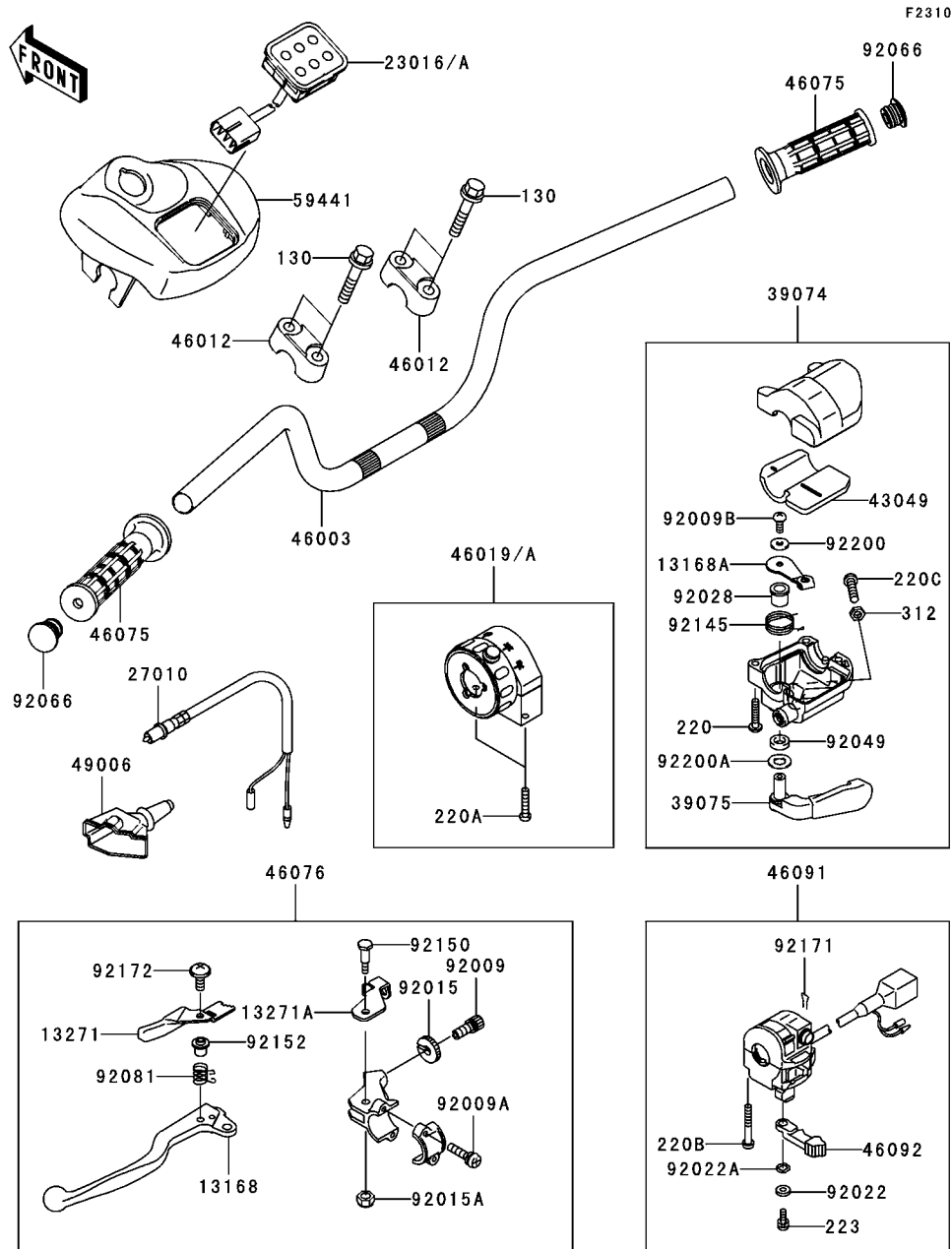

Ref. No.	Part No.	Description	Spec Code	Quantity-KSV700			
				'04	'05		
				A1	A2		
220C	220C0625	SCREW-PAN-CROS,6X25,BLACK	1	1			
223	223C0512	SCREW-PAN-WS-CROS	1	1			
312	312C0600	NUT-HEX,6MM,BLACK	1	1			

This catalog covers:

'04~'05 KSV700-A1/A2 Chassis

GRID NO.

F-7

This grid covers:

Fuel Tank

F2410

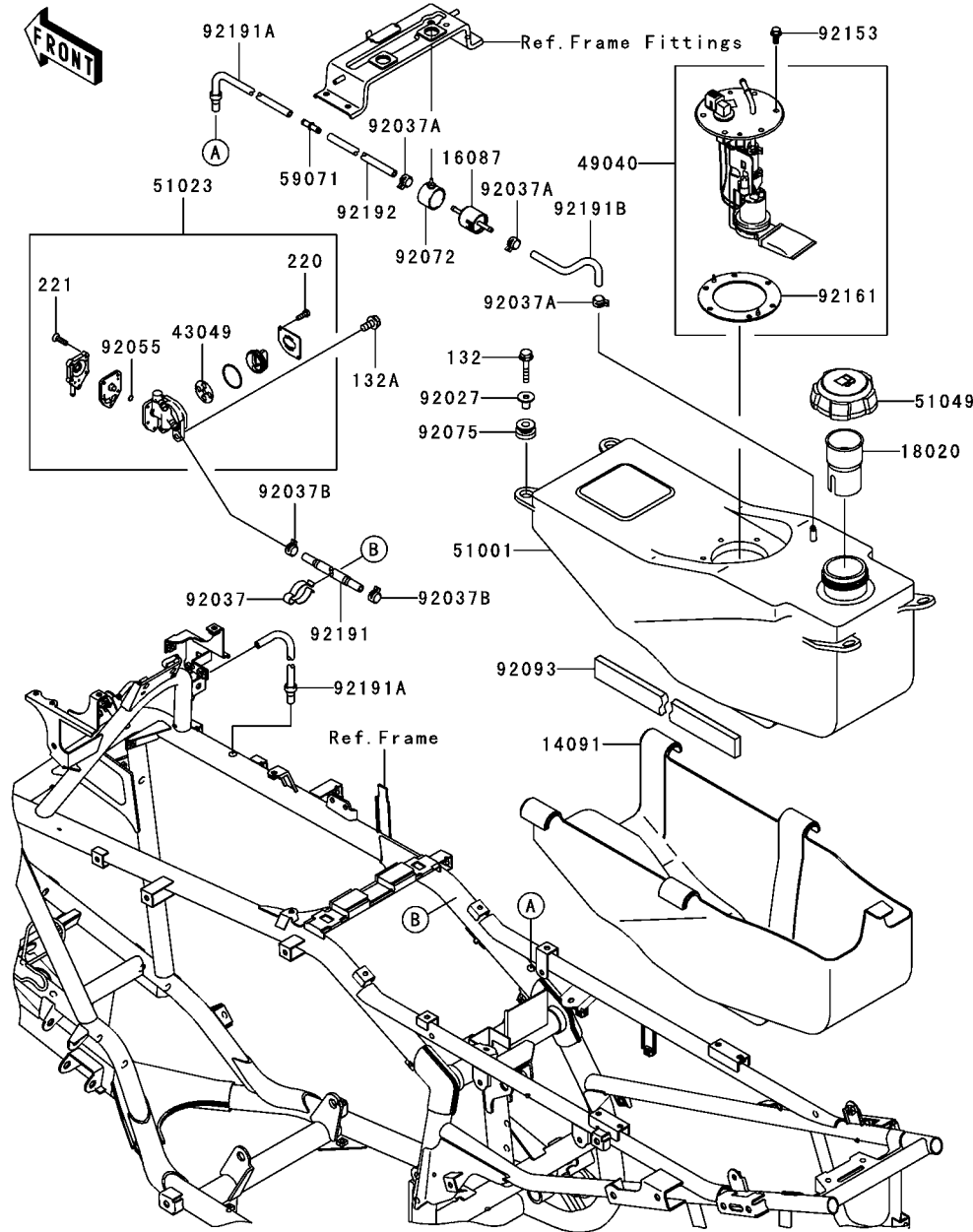

Ref. No.	Part No.	Description	Spec Code	Quantity-KSV700			
				'04	'05		
				A1	A2		
14091	14091-1513	COVER,FUEL TANK		1	1		
16087	16087-1054	VALVE-CHECK		1	1		
18020	18020-1307	BAFFLE		1	1		
43049	43049-1103	PACKING		1	1		
49040	49040-1080	PUMP-FUEL		1	1		
51001	51001-0013	TANK-COMP-FUEL		1	1		
51023	51023-1406	TAP-ASSY,FUEL		1	1		
51049	51049-1128	CAP-TANK,FUEL		1	1		
59071	59071-3717	JOINT		1	1		
92027	92027-1847	COLLAR,L=16.1		4	4		
92037	92037-093	CLAMP		1	1		
92037A	92037-1461	CLAMP,TUBE		3	3		
92037B	92037-1505	CLAMP,TUBE		2	2		
92055	92055-1664	RING-O		1	1		
92072	92072-1438	BAND		1	1		
92075	92075-1787	DAMPER		4	4		
92093	92093-0007	SEAL		1	1		
92153	92153-0361	BOLT,FLANGED,5MM		6	6		
92161	92161-0027	DAMPER,FUEL PUMP		1	1		
92191	92191-0034	TUBE,5.3X10.5X850		1	1		
92191A	92191-1666	TUBE,TANK BREATHER		2	2		
92191B	92191-1773	TUBE,CHECK VALVE-TANK		1	1		
92192	92192-0020	TUBE,JOINT-CHECK VALVE		1	1		
132	132G0630	BOLT-FLANGED-SMALL		4	4		
132A	132J0612	BOLT-FLANGED-SMALL		2	2		
220	220B0308	SCREW-PAN-CROS		2	2		
221	221B0414	SCREW-CSK-CROS,4X14		5	5		

This catalog covers:

'04~'05 KSV700-A1/A2 Chassis

GRID NO.

F-8

This grid covers:

Seat

F2510

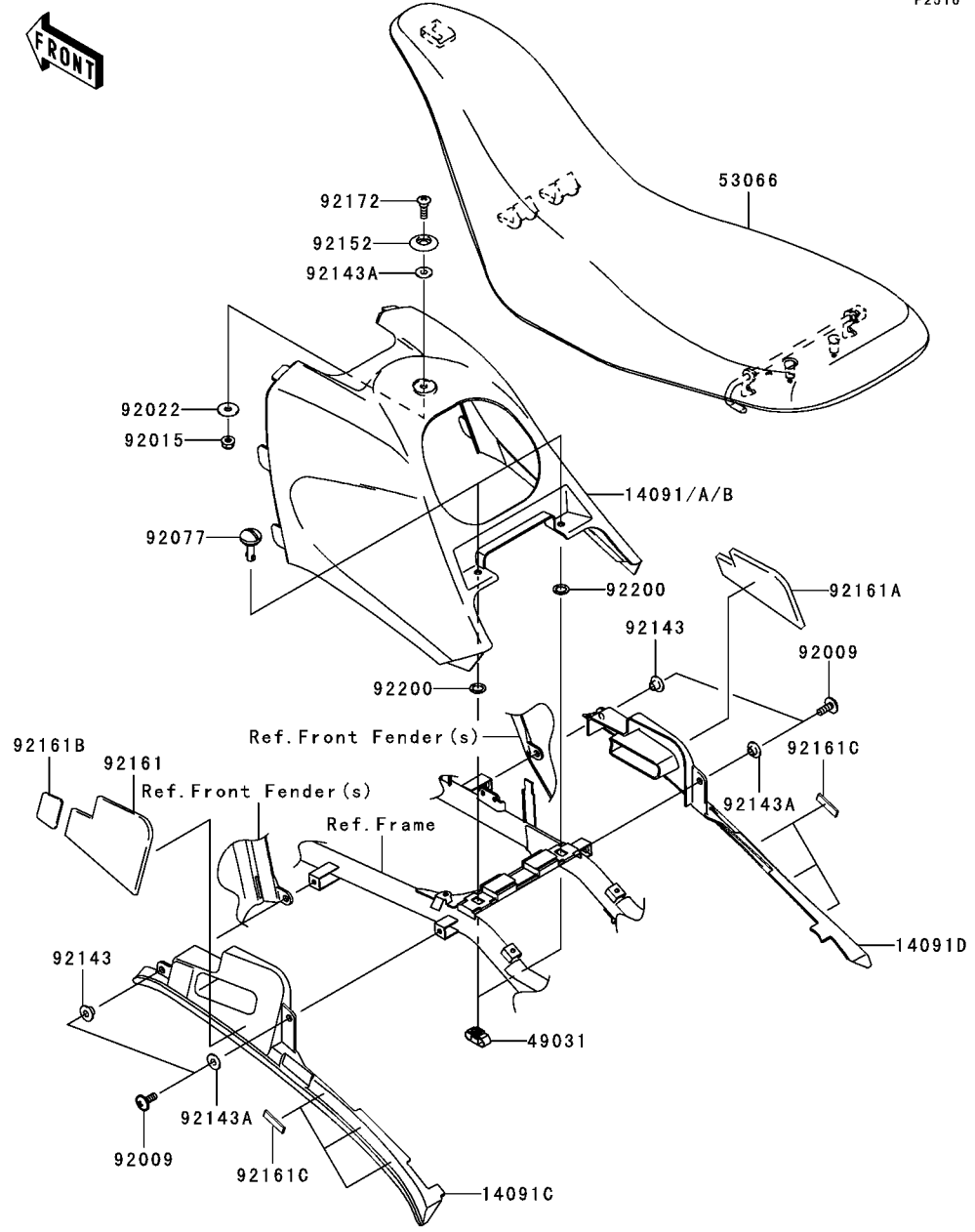

Ref. No.	Part No.	Description	Spec Code	Quantity-KSV700			
				'04	'05		
				A1	A2		
14091	14091-0075-268	COVER,AIR CLEANER,B.ORANGE					
		L-----AS	1				
		L-----EU		1			
14091A	14091-0075-290	COVER,AIR CLEANER,L.GREEN					
14091B	14091-0075-6W	COVER,AIR CLEANER,L.GREEN	1				
14091C	14091-0089-6Z	COVER,SIDE,LH,F.BLACK	1	1			
14091D	14091-0090-6Z	COVER,SIDE,RH,F.BLACK	1	1			
49031	49031-1060	LATCH	2	2			
53066	53066-0003-MA	SEAT-ASSY,BLACK	1	1			
92009	92009-1621	SCREW,6X16	4	4			
92015	92015-1603	NUT,LOCK,FLANGED,6MM	1	1			
92022	92022-125	WASHER,6.5X20X1.6	1	1			
92077	92077-1129	KNOB	2	2			
92143	92143-1057	COLLAR	2	2			
92143A	92143-1087	COLLAR	3	3			
92152	92152-1346	COLLAR	1	1			
92161	92161-0059	DAMPER,SIDE COVER,LH	1	1			
92161A	92161-0060	DAMPER,SIDE COVER,RH	1	1			
92161B	92161-0061	DAMPER,SIDE COVER	2	2			
92161C	92161-0090	DAMPER	6	6			
92172	92172-0062	SCREW,6X19.5	1	1			
92200	92200-1578	WASHER	2	2			

This catalog covers:

'04~'05 KSV700-A1/A2 Chassis

GRID NO.

F-9

This grid covers:

Cables

F2540

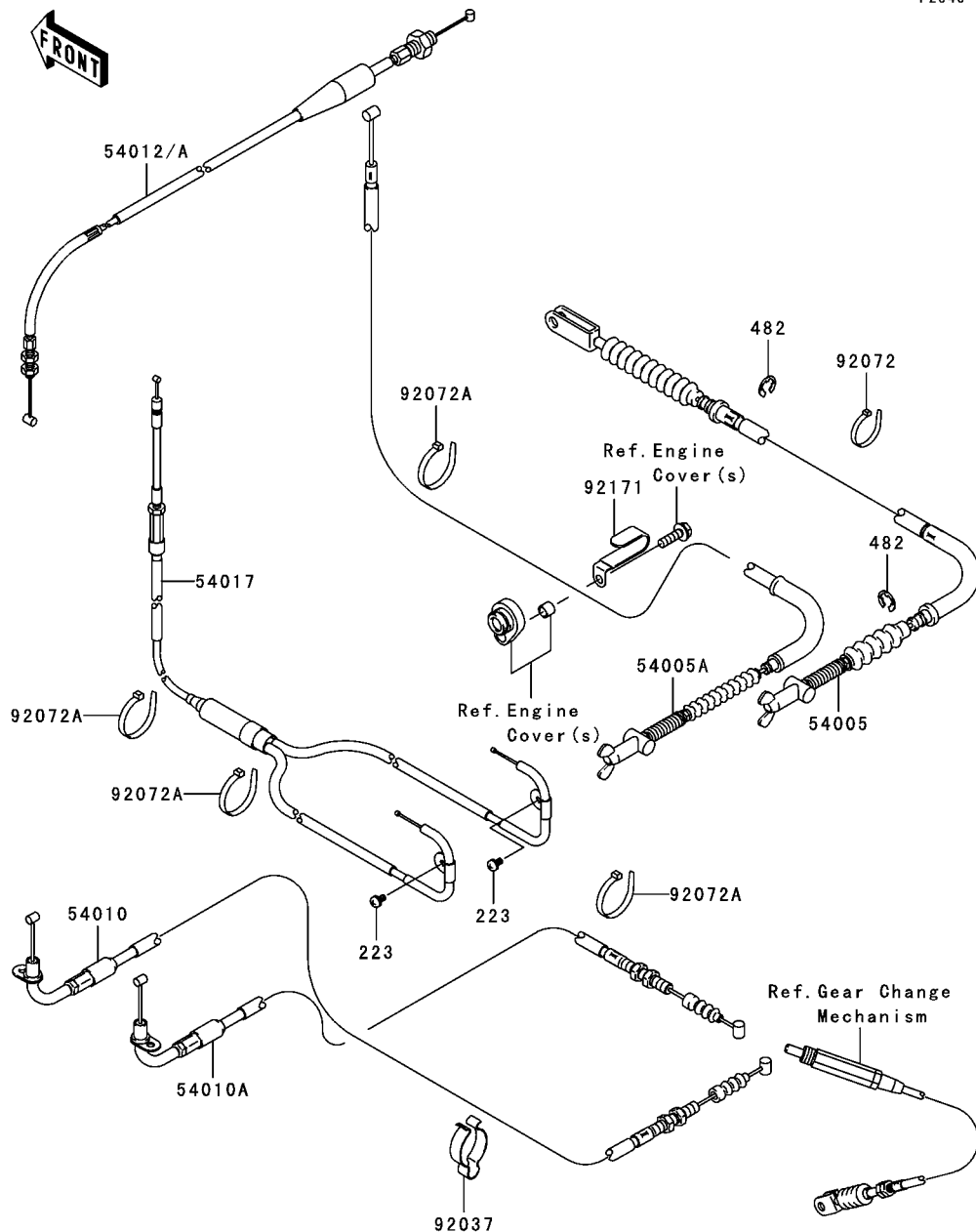

Ref. No.	Part No.	Description	Quantity-KSV700			
			'04	'05		
			A1	A2		
54005	54005-1217	CABLE-BRAKE,REAR	1	1		
54005A	54005-1218	CABLE-BRAKE,PARKING	1	1		
54010	54010-1130	CABLE,SHIFT,PULL	1	1		
54010A	54010-1131	CABLE,SHIFT,PUSH	1	1		
54012	54012-0040	CABLE-THROTTLE	1			
54012A	54012-0124	CABLE-THROTTLE		1		
54017	54017-1226	CABLE-STARTER	1	1		
92037	92037-093	CLAMP	1	1		
92072	92072-030	BAND,L=123	1	1		
92072A	92072-1239	BAND,L=188	4	4		
92171	92171-1230	CLAMP	1	1		
223	223D0408	SCREW-PAN-WS-CROS	2	2		
482	482L8000	CIRCLIP-TYPE-E,8MM	2	2		

This catalog covers:

'04~'05 KSV700-A1/A2 Chassis

GRID NO.

F-10

This grid covers:

Guard(s)

F2680

Ref. No.	Part No.	Description	Spec Code	Quantity-KSV700			
				'04	'05		
				A1	A2		

55020	55020-0010-HN	GUARD,FR,G.GRAY		1	1		
55020A	55020-0011	GUARD,FUEL TANK		1	1		
55020B	55020-0032	GUARD,SWING ARM		1	1		
55020C	55020-1802	GUARD,ENGINE		1	1		
55020D	55020-1810-HN	GUARD,BELT CONVERTER,G.GRAY		1	1		
92075	92075-157	DAMPER		2	2		
92075A	92075-261	DAMPER,RUBBER		6	6		
130	130J0610	BOLT-FLANGED		4	4		
130A	130J0612	BOLT-FLANGED		4	4		
130B	130J0814	BOLT-FLANGED,8X14		5	5		
132	132J0612	BOLT-FLANGED-SMALL		2	2		
132A	132J0816	BOLT-FLANGED-SMALL,8X16		2	2		

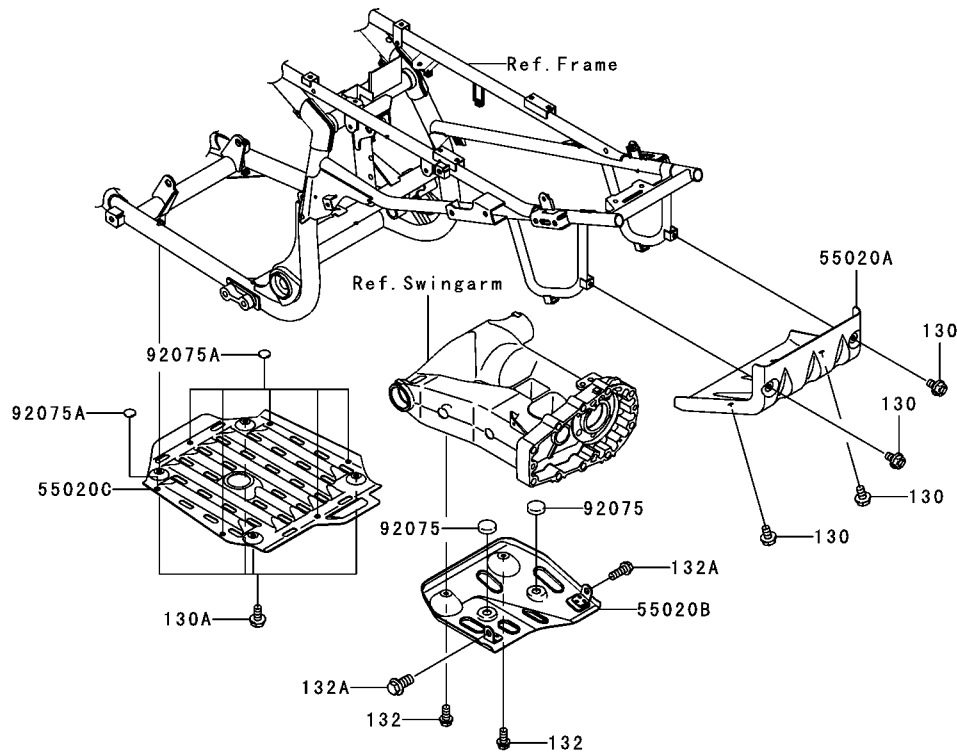
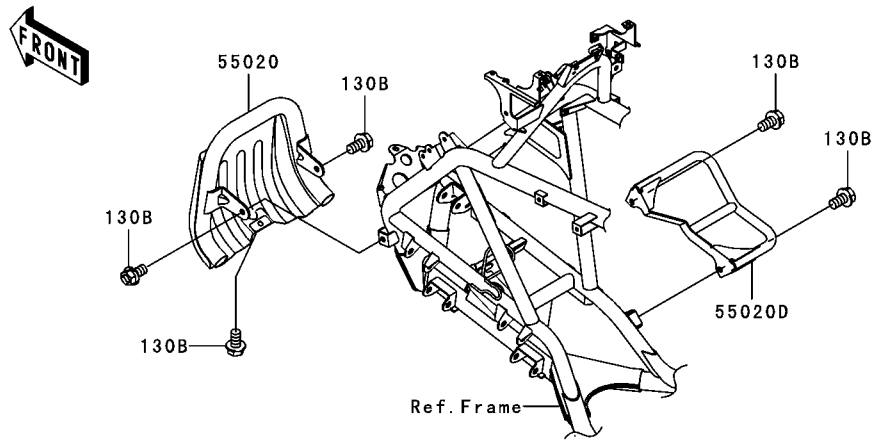

This catalog covers:

'04~'05 KSV700-A1/A2 Chassis

GRID NO.

F-11

This grid covers:

Headlight(s)

F2710

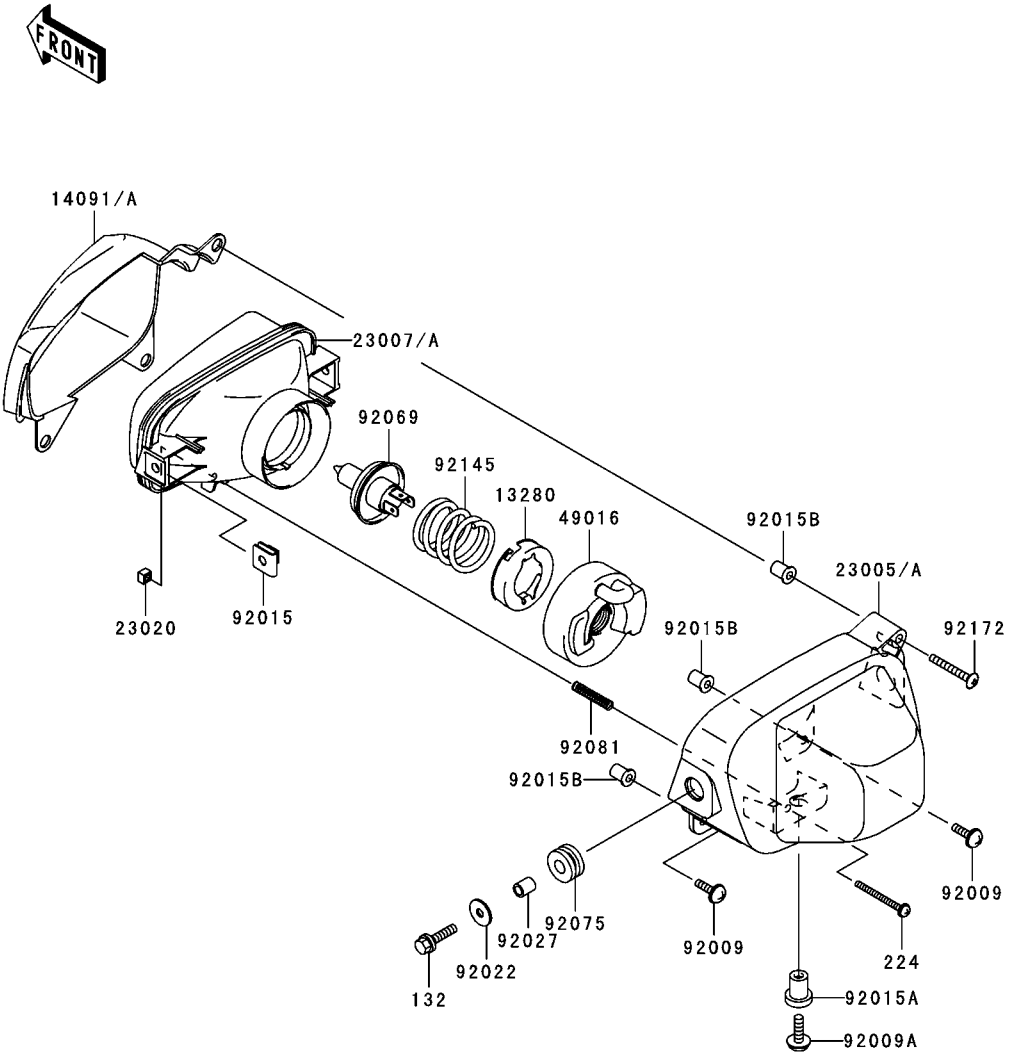

Ref. No.	Part No.	Description	Spec Code	Quantity-KSV700			
				'04	'05		
				A1	A2		
13280	13280-1198	HOLDER,BULB SETTING	2	2			
14091	14091-0061-6Z	COVER,HEAD LAMP GRILL,LH,BLACK	1	1			
14091A	14091-0062-6Z	COVER,HEAD LAMP GRILL,RH,BLACK	1	1			
23005	23005-1180	BODY-COMP-HEAD LAMP,LH	1	1			
23005A	23005-1181	BODY-COMP-HEAD LAMP,RH	1	1			
23007	23007-1389	LENS-COMP,HEAD LAMP,LH	1	1			
23007A	23007-1390	LENS-COMP,HEAD LAMP,RH	1	1			
23020	23020-018	NUT,4MM,FOCUS ADJUST	2	2			
49016	49016-1213	COVER-SEAL,HEAD LAMP	2	2			
92009	92009-1654	SCREW,5X16,BLACK	4	4			
92009A	92009-1664	SCREW,6X22	2	2			
92015	92015-1094	NUT,6MM	4	4			
92015A	92015-1692	NUT,RUBBER,6MM	2	2			
92015B	92015-1757	NUT,WELL,5MM	6	6			
92022	92022-125	WASHER,6.5X20X1.6	4	4			
92027	92027-162	COLLAR,6.8X10X12	4	4			
92069	92069-1114	BULB,12V 45/45W,T15	2	2			
92075	92075-1690	DAMPER	4	4			
92081	92081-1896	SPRING,FOCUS ADJUST	2	2			
92145	92145-1346	SPRING,BULB SETTING	2	2			
92172	92172-0063	SCREW,5X40	2	2			
132	132H0625	BOLT-FLANGED-SMALL,6X25	4	4			
224	224D0445	SCREW-PAN-WP-CROS	2	2			

This catalog covers:

'04~'05 KSV700-A1/A2 Chassis

GRID NO.

F-12

This grid covers:

Taillight(s)

F2720

Ref. No.	Part No.	Description	Spec Code	Quantity-KSV700			
				'04	'05		
				A1	A2		
11051	11051-1870	BRACKET,TAIL LAMP	1	1			
11061	11061-0055	GASKET,TAIL LAMP LENS	1	1			
14091	14091-0095-6Z	COVER,TAIL LAMP,F.BLACK	1	1			
23024	23024-1130	LAMP-ASSY-TAIL	1	1			
23026	23026-1230	LENS,TAIL LAMP	1	1			
23036	23036-0001	BRACKET-TAIL LAMP	1	1			
92009	92009-1621	SCREW,6X16	3	3			
92015	92015-1678	NUT,CLAMP,6MM	1	1			
92027	92027-1964	COLLAR,L=4.7	2	2			
92069	92069-063	BULB,12V 21/5W	1	1			
92143	92143-1087	COLLAR	1	1			
92160	92160-1053	DAMPER,TAIL LAMP	2	2			
92172	92172-1061	SCREW,TAPPING,5X10	2	2			
220	220B0440	SCREW-PAN-CROS	2	2			

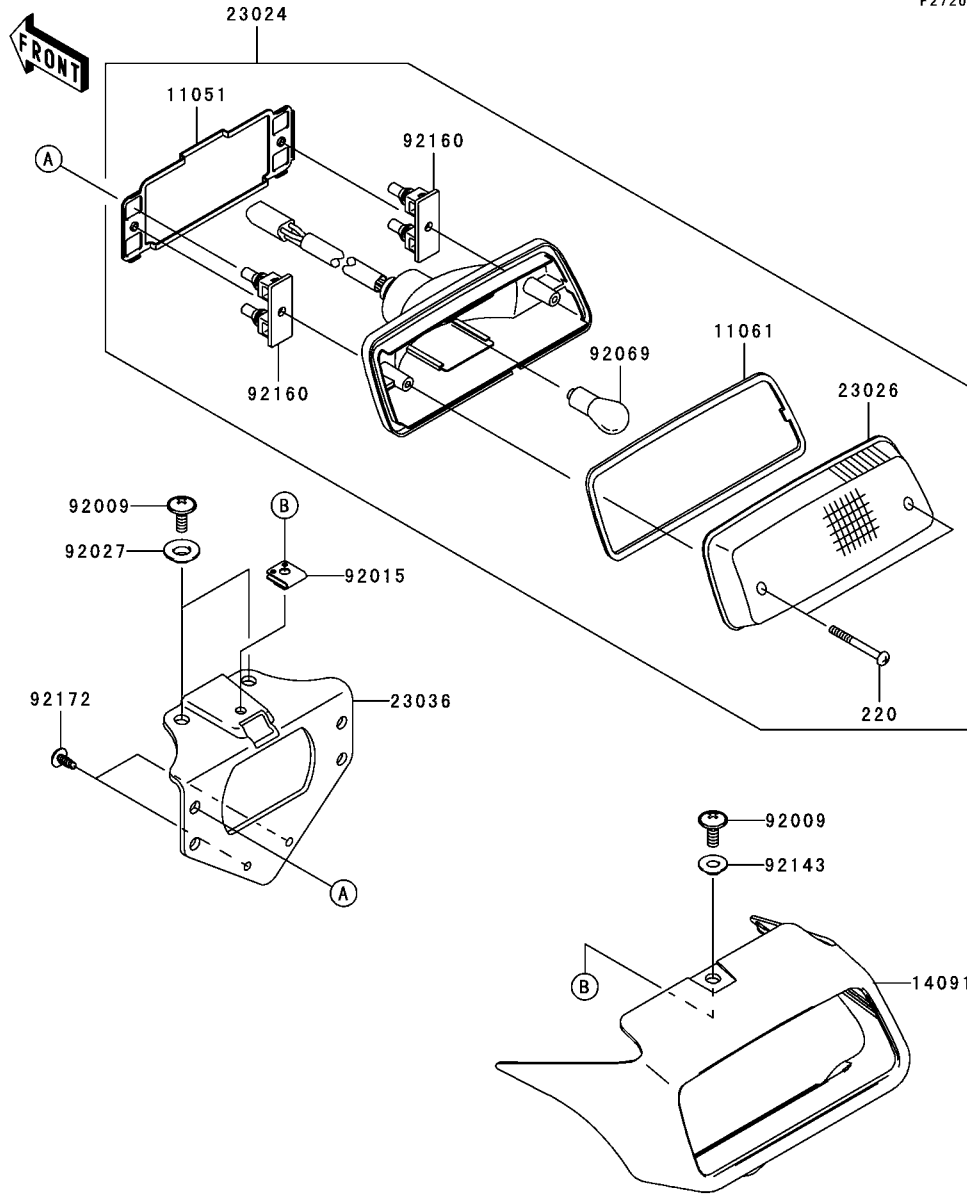

This catalog covers:

'04~'05 KSV700-A1/A2 Chassis

GRID NO.

F-13

This grid covers:

Chassis Electrical Equipment

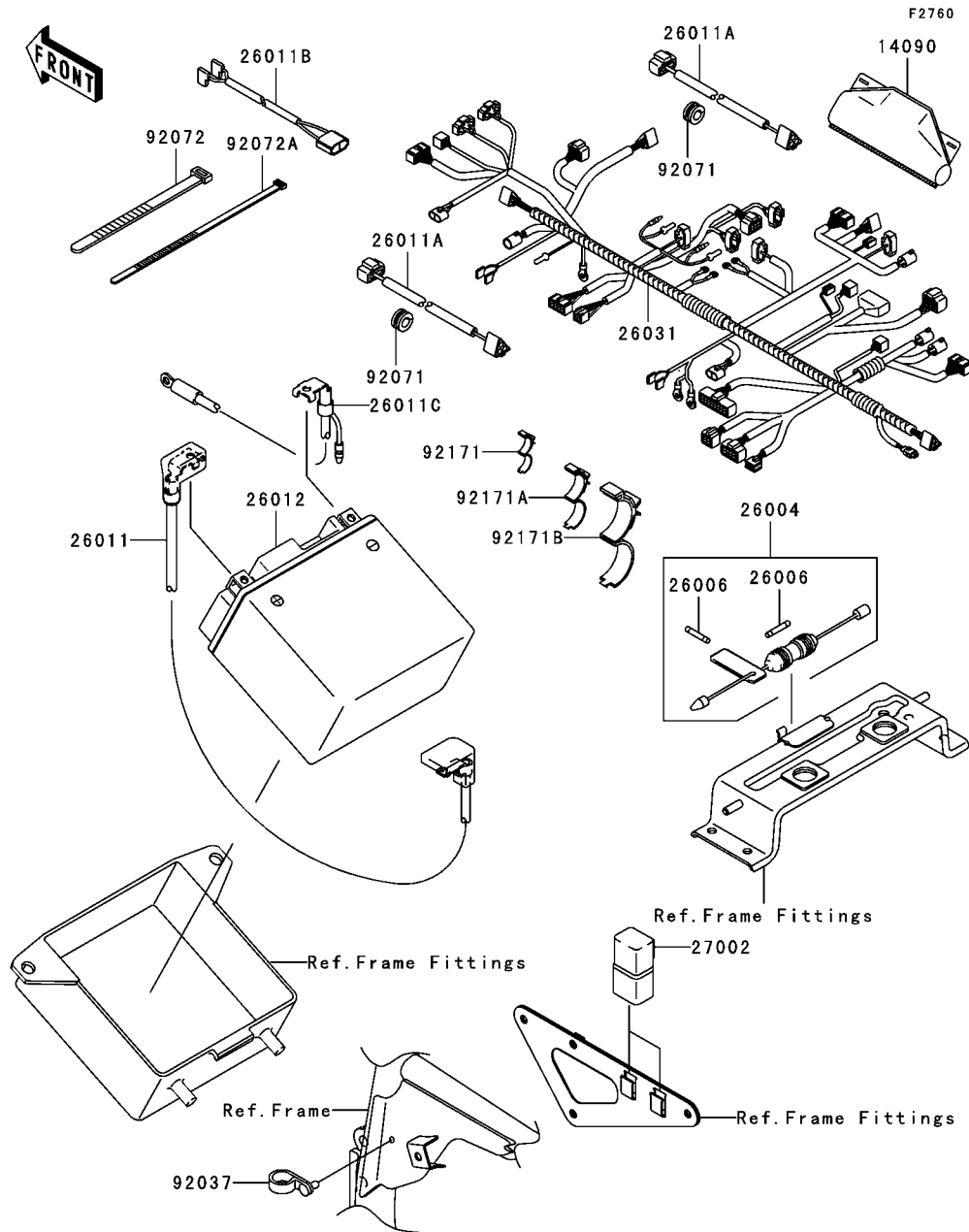

Ref. No.	Part No.	Description	Spec Code	Quantity-KSV700			
				'04	'05		
				A1	A2		
14090	14090-1331	COVER, COUPLER	1	1			
26004	26004-7501	FUSE-ASSY	1	1			
26006	26006-1064	FUSE, 20A, L=32	2	2			
26011	26011-0009	WIRE-LEAD, BATTERY(+)	1	1			
26011A	26011-1741	WIRE-LEAD, HEAD LAMP	2	2			
26011B	26011-1802	WIRE-LEAD, FRONT BRAKE	1	1			
26011C	26011-1847	WIRE-LEAD, BATTERY(-)	1	1			
26012	26012-1414	BATTERY, MF, KMX14-BS, 12V 12AH	1	1			
26031	26031-0011	HARNESS, MAIN	1	1			
27002	27002-1086	RELAY-ASSY	2	2			
92037	92037-1163	CLAMP, SPEED, L=58	1	1			
92071	92071-1128	GROMMET	2	2			
92072	92072-030	BAND, L=123	1	1			
92072A	92072-1239	BAND, L=188	2	2			
92171	92171-1423	CLAMP, DIA=10	5	5			
92171A	92171-1424	CLAMP, DIA=15	2	2			
92171B	92171-1559	CLAMP, DIA=25	2	2			

This catalog covers:

'04~'05 KSV700-A1/A2 Chassis

GRID NO.

F-14

This grid covers:

Ignition Switch

F2770

Ref. No.	Part No.	Description	Spec Code	Quantity-KSV700			
				'04	'05		
				A1	A2		
14024	14024-1551 (OPTION)	COVER,KEY		4	4		
27005	27005-1267	SWITCH-ASSY-IGNITION		1	1		
27008	27008-1041 (OPTION)	KEY-LOCK,BLANK		1	1		
27008A	27008-1042 (OPTION)	KEY-LOCK,BLANK		1	1		
27008B	27008-1043 (OPTION)	KEY-LOCK,BLANK		1	1		
27008C	27008-1044 (OPTION)	KEY-LOCK,BLANK		1	1		
27008D	27008-1132 (OPTION)	KEY-LOCK,BLANK		1	1		
27008E	27008-1133 (OPTION)	KEY-LOCK,BLANK		1	1		
27008F	27008-1134 (OPTION)	KEY-LOCK,BLANK		1	1		
27008G	27008-1135 (OPTION)	KEY-LOCK,BLANK		1	1		
27010	27010-1421	SWITCH,INVERT SENSOR		1	1		
92009	92009-1897	SCREW,4X20		2	2		
92210	92210-1109	NUT,IGNITION SWITCH		1	1		

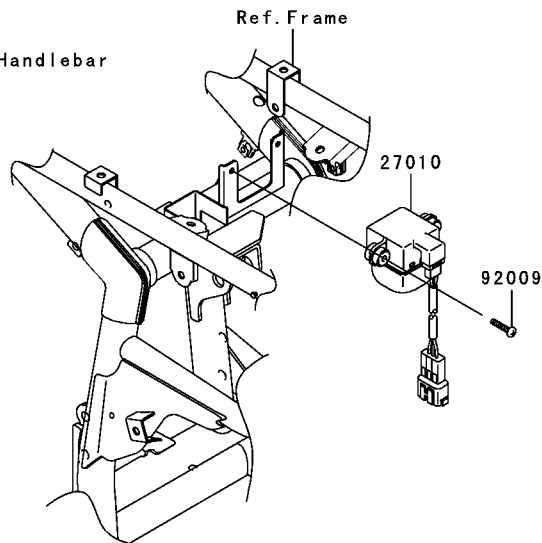
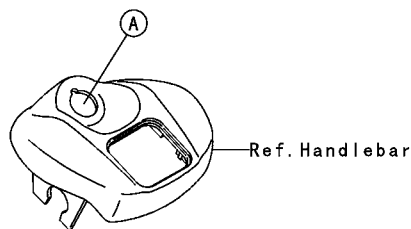
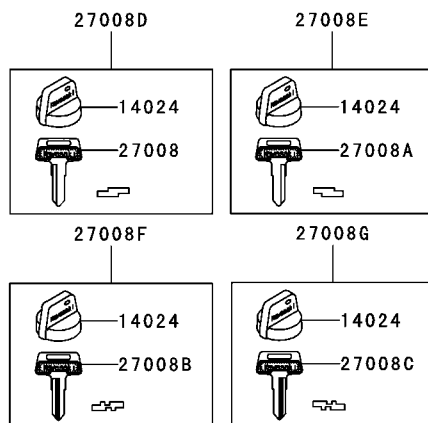
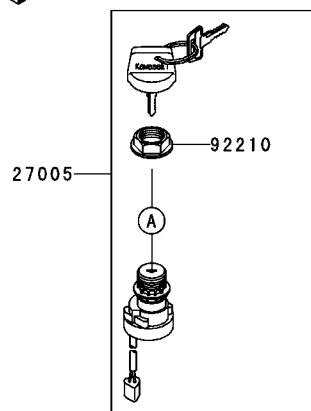

This catalog covers:

'04~'05 KSV700-A1/A2 Chassis

GRID NO.

G-3

This grid covers:

Owner's Tools

F2810

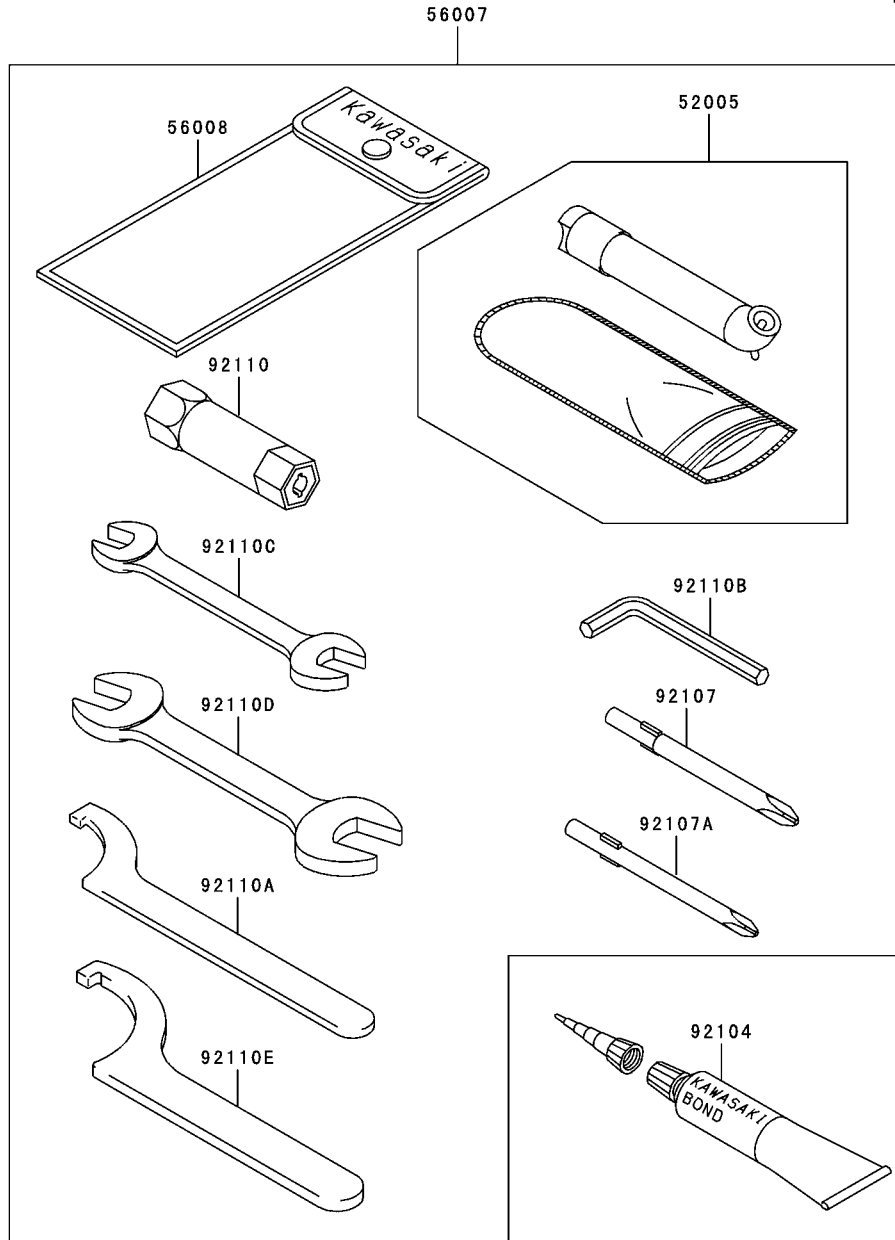

Ref. No.	Part No.	Description	Spec Code	Quantity-KSV700			
				'04	'05		
				A1	A2		
52005	52005-1082	GAUGE,AIR	1	1			
56007	56007-0001	TOOL-KIT	1	1			
56008	56008-1007	BAG,TOOL	1	1			
92104	92104-002	GASKET-LIQUID,TUBE,100G,SILVER	1	1			
92107	92107-005	TOOL-DRIVER,#3PHILLIPS	1	1			
92107A	92107-1053	TOOL-DRIVER,#2PHILLIPS	1	1			
92110	92110-1116	TOOL-WRENCH,BOX,16MM	1	1			
92110A	92110-1129	TOOL-WRENCH,HOOK	1	1			
92110B	92110-1140	TOOL-WRENCH,ALLEN,3MM	1	1			
92110C	92110-1152	TOOL-WRENCH,OPEN END,10X12	1	1			
92110D	92110-1153	TOOL-WRENCH,OPEN END,14X17	1	1			
92110E	92110-1173	TOOL-WRENCH,HOOK	1	1			

This catalog covers:

'04~'05 KSV700-A1/A2 Chassis

GRID NO.

G-4

This grid covers:

Labels(A1)

F2860

Ref. No.	Part No.	Description	Spec Code	Quantity-KSV700			
				'04	'05		
				A1	A2		

56030	56030-0018	LABEL,IGNITION SWITCH					1
56033	56033-0001	LABEL-MANUAL,DRIVE BELT INFO					1
56033A	56033-0002	LABEL-MANUAL,BELT CONVERTER					1
		L----- EU					
56033B	56033-0023	LABEL-MANUAL,SEAT LATCH					1
56033C	56033-1263	LABEL-MANUAL,MANUAL					1
56040	56040-1157	LABEL,UNLEADED PETROL ONLY					1
		L----- AS					
56040A	56040-1261	LABEL-WARNING,TRANSPORT					1
		L----- AS					
56070	56070-0004	LABEL-WARNING,TIRE INFO					1
		L----- AS					
56070A	56070-0007	LABEL-WARNING,TIRE INFO					1
		L----- EU					
56070B	56070-1108	LABEL-WARNING,FUEL UNLEADED					1
		L----- EU					
56070C	56070-1110	LABEL-WARNING,AGE RECOMMEND					1
		L----- EU					
56070D	56070-1170	LABEL-WARNING,SHIFT LEVER					1
56070E	56070-1179	LABEL-WARNING,SHIFT LEVER(FREN					1
		L----- EU					
56070F	56070-1269	LABEL-WARNING,CVT COVER					1
56070G	56070-1271	LABEL-WARNING,CVT COVER(FRENCH					1
		L----- EU					
56070H	56070-1286	LABEL-WARNING,GENERAL					1
		L----- AS					
56070I	56070-1291	LABEL-WARNING,MAX VEHICLE LOAD					1
		L----- AS					
56070J	56070-1292	LABEL-WARNING,GENERAL					1
		L----- EU					
92039	92039-3763	RIVET,3.2X8					6
92200	92200-1251	WASHER,3.5X8X1					6

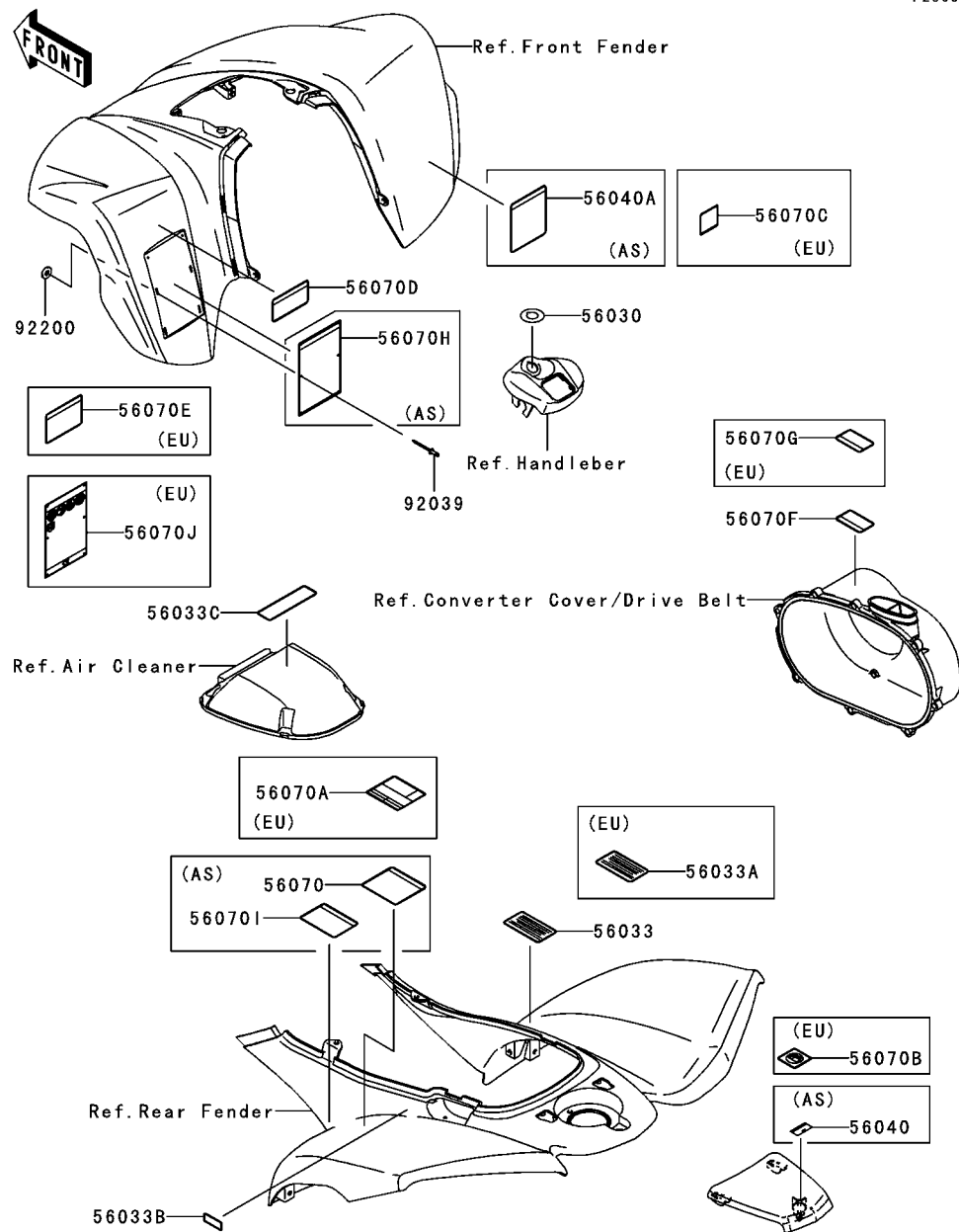

This catalog covers:

'04~'05 KSV700-A1/A2 Chassis

GRID NO.

G-5

This grid covers:

Labels(A2)

F2860A

Ref. No.	Part No.	Description	Spec Code	Quantity-KSV700			
				'04	'05		
				A1	A2		
56030	56030-0018	LABEL,IGNITION SWITCH				1	
56033	56033-0001	LABEL-MANUAL,DRIVE BELT INFO				1	
56033A	56033-0002	LABEL-MANUAL,BELT CONVERTER				1	
		L----- EU					
56033B	56033-0023	LABEL-MANUAL,SEAT LATCH				1	
56033C	56033-1263	LABEL-MANUAL,MANUAL				1	
56040	56040-1157	LABEL,UNLEADED PETROL ONLY				1	
		L----- AS					
56070	56070-0007	LABEL-WARNING,TIRE INFO				1	
		L----- EU					
56070A	56070-0022	LABEL-WARNING,TIRE&MAX LOAD				1	
		L----- AS					
56070B	56070-0037	LABEL-WARNING,SHIFT LEVER(FREN				1	
		L----- EU					
56070C	56070-1108	LABEL-WARNING,FUEL UNLEADED				1	
		L----- EU					
56070D	56070-1110	LABEL-WARNING,AGE RECOMMEND				1	
		L----- EU					
56070E	56070-1170	LABEL-WARNING,SHIFT LEVER				1	
56070F	56070-1269	LABEL-WARNING,CVT COVER				1	
56070G	56070-1271	LABEL-WARNING,CVT COVER(FRENCH				1	
		L----- EU					
56070H	56070-1286	LABEL-WARNING,GENERAL				1	
		L----- AS					
56070I	56070-1292	LABEL-WARNING,GENERAL				1	
		L----- EU					
92039	92039-3763	RIVET,3.2X8				6	
92200	92200-1251	WASHER,3.5X8X1				6	

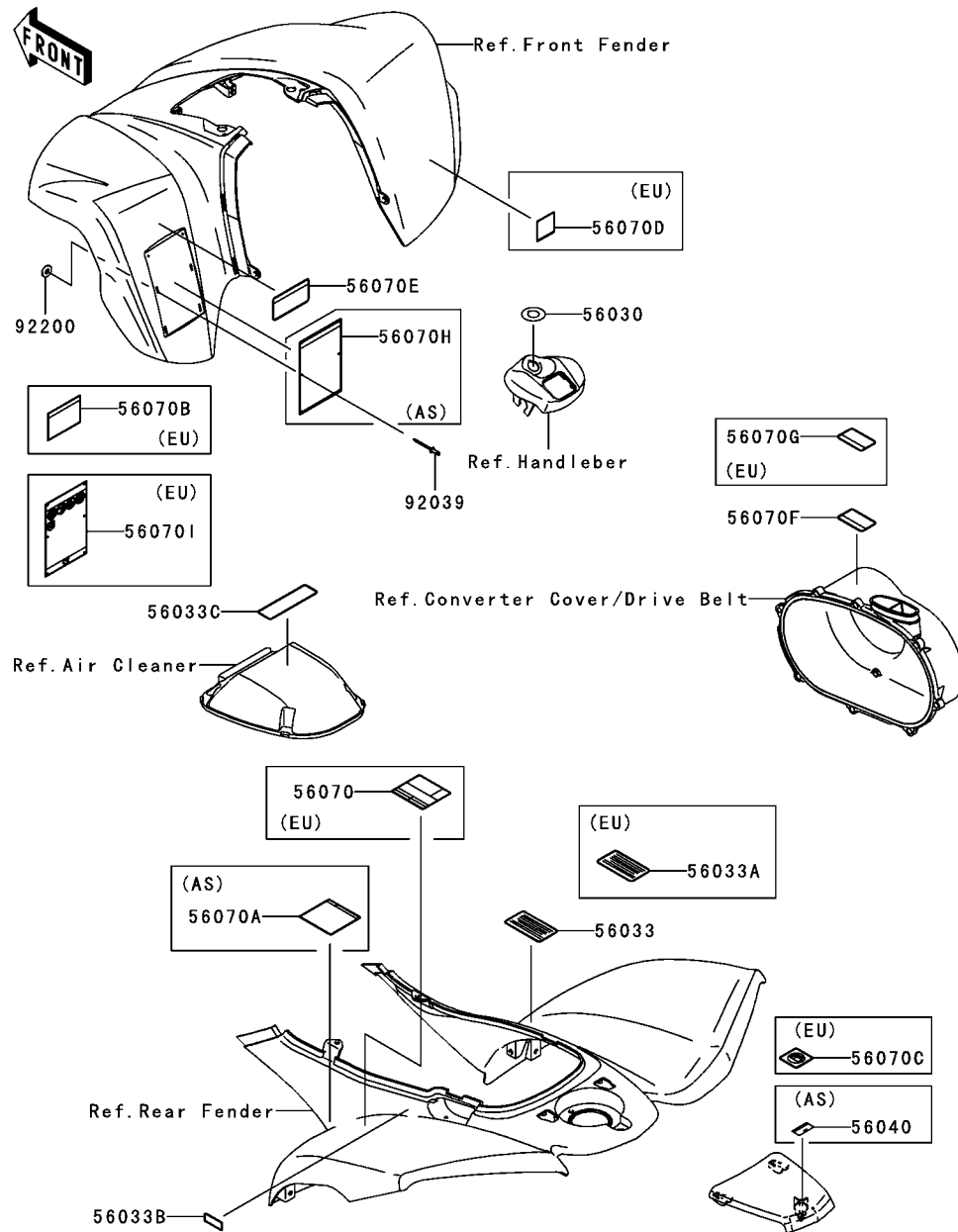

This catalog covers:

'04~'05 KSV700-A1/A2 Chassis

GRID NO.

G-6

This grid covers:

Decals(Orange)(A1)(AS)

F2861

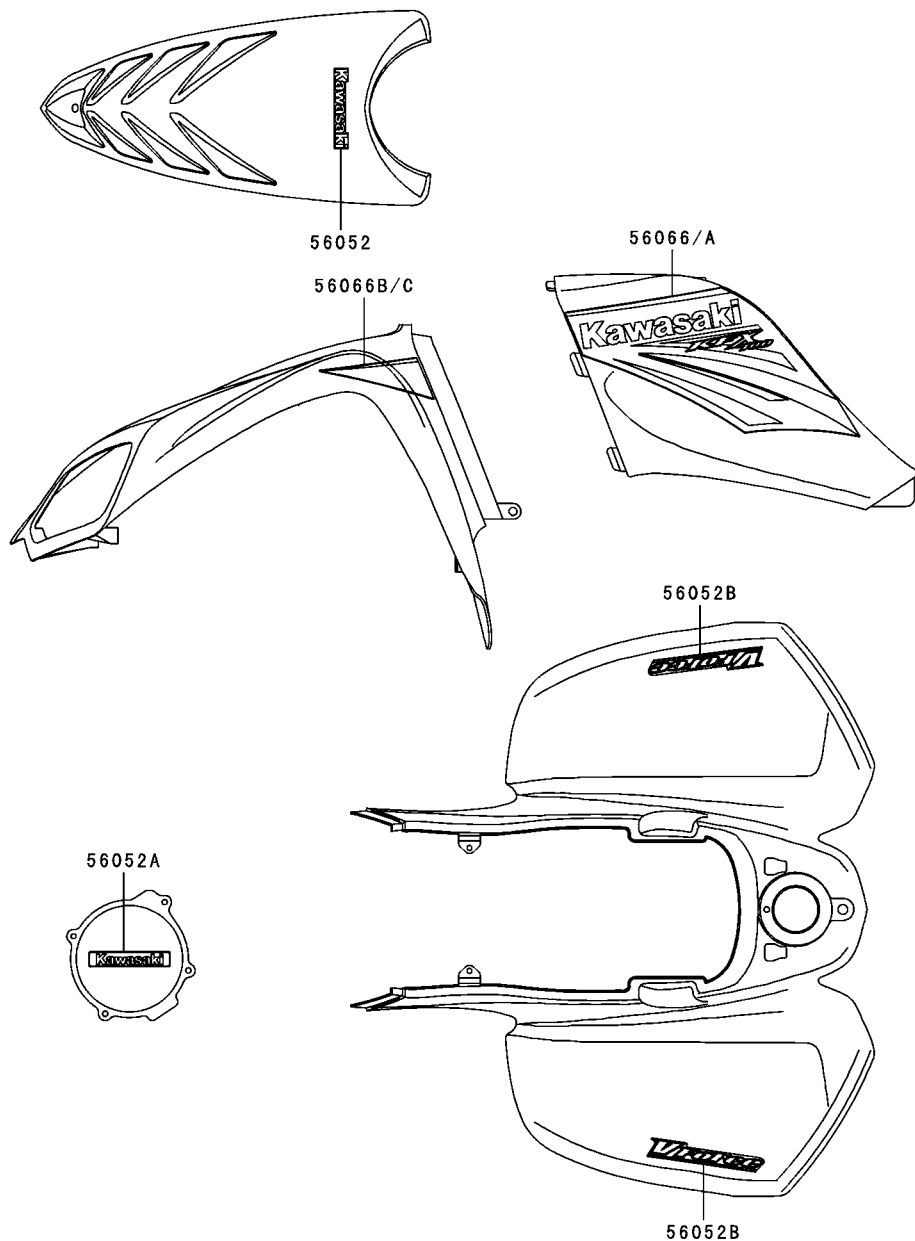

Ref. No.	Part No.	Description	Spec Code	Quantity-KSV700			
				'04	'05		
				A1	A2		
56052	56052-0060	MARK,KAWASAKI					
	L-----		AS	1			
56052A	56052-0061	MARK,RECOIL COVER,KAWASAKI					
	L-----		AS	1			
56052B	56052-0103	MARK,RR FENDER,V FORCE					
	L-----		AS	2			
56066	56066-0241	PATTERN,AIR CLEANER COVER,LH					
	L-----		AS	1			
56066A	56066-0242	PATTERN,AIR CLEANER COVER,RH					
	L-----		AS	1			
56066B	56066-0243	PATTERN,FR FENDER,LH					
	L-----		AS	1			
56066C	56066-0244	PATTERN,FR FENDER,RH					
	L-----		AS	1			

This catalog covers:

'04~'05 KSV700-A1/A2 Chassis

GRID NO.

G-7

This grid covers:

Decals(Green)(A1)

F2861A

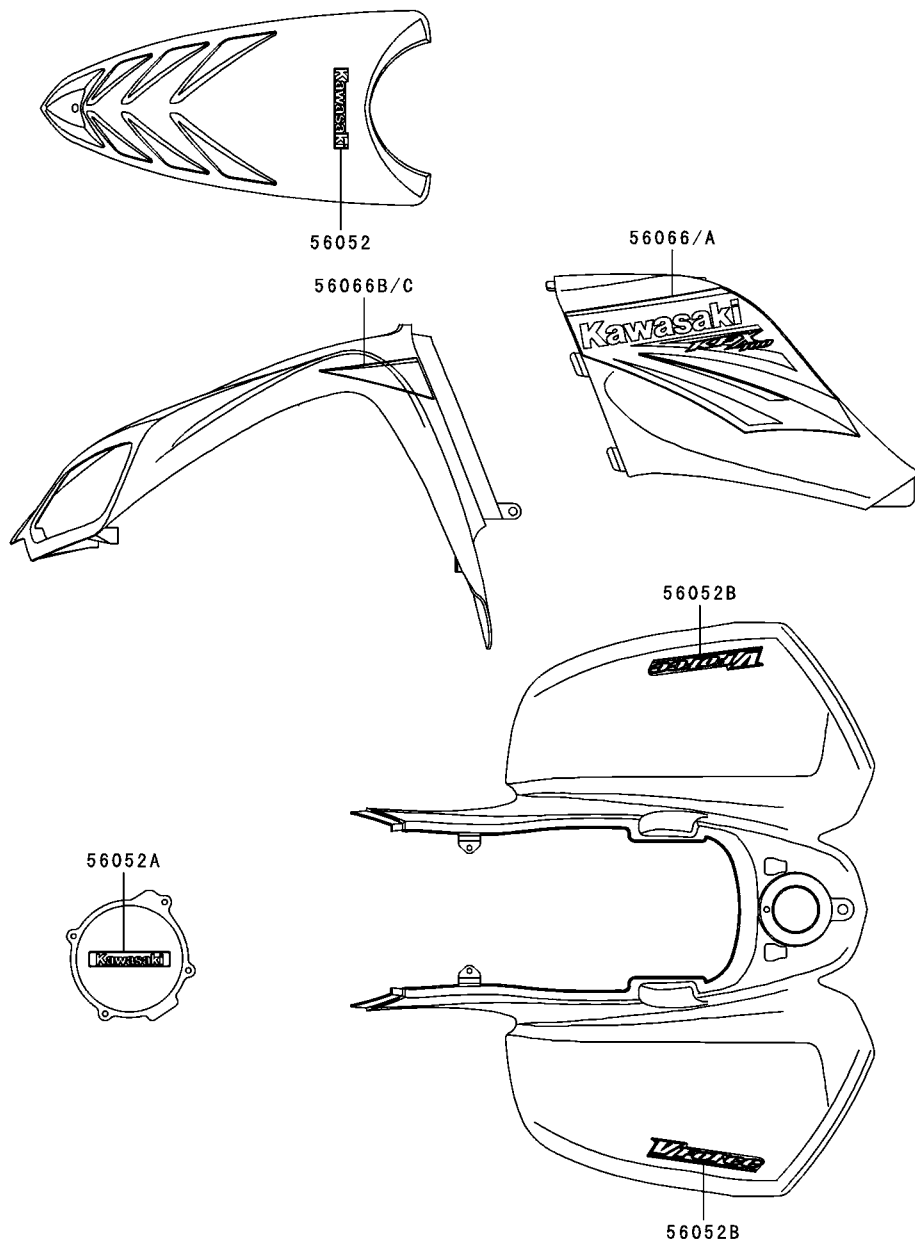

Ref. No.	Part No.	Description	Spec Code	Quantity-KSV700			
				'04	'05		
				A1	A2		
56052	56052-0060	MARK,KAWASAKI					1
56052A	56052-0061	MARK,RECOIL COVER,KAWASAKI					1
56052B	56052-0102	MARK,RR FENDER,V FORCE					2
56066	56066-0237	PATTERN,AIR CLEANER COVER,LH					1
56066A	56066-0238	PATTERN,AIR CLEANER COVER,RH					1
56066B	56066-0239	PATTERN,FR FENDER,LH					1
56066C	56066-0240	PATTERN,FR FENDER,RH					1

This catalog covers:

'04~'05 KSV700-A1/A2 Chassis

GRID NO.

G-8

This grid covers:

Decals(Orange)(A2)(EU)

F2861B

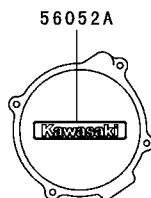
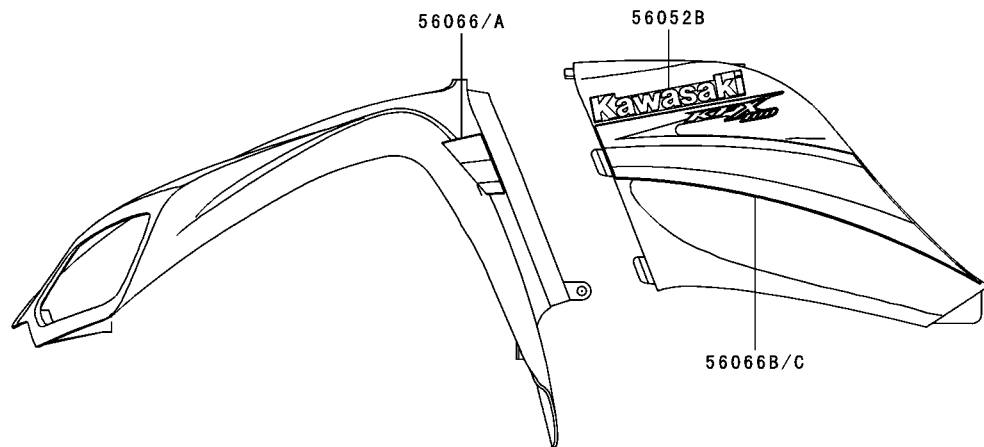
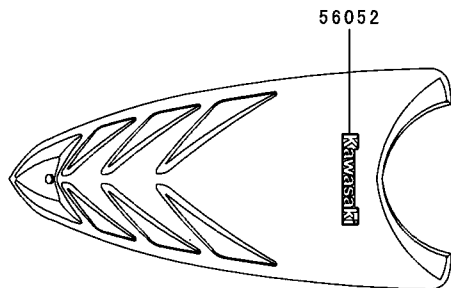

Ref. No.	Part No.	Description	Spec Code	Quantity-KSV700			
				'04	'05		
				A1	A2		
56052	56052-0060	MARK,KAWASAKI					
		L-----	EU				
56052A	56052-0061	MARK,RECOIL COVER,KAWASAKI					
		L-----	EU				
56052B	56052-0377	MARK,FUEL TANK COVER,KAWASAKI					
		L-----	EU				
56066	56066-1018	PATTERN,FR FENDER,LH					
		L-----	EU				
56066A	56066-1019	PATTERN,FR FENDER,RH					
		L-----	EU				
56066B	56066-1020	PATTERN,FUEL TANK COVER,LH					
		L-----	EU				
56066C	56066-1021	PATTERN,FUEL TANK COVER,RH					
		L-----	EU				

This catalog covers:

'04~'05 KSV700-A1/A2 Chassis

GRID NO.

G-9

This grid covers:

Decals(Green)(A2)

F2861C

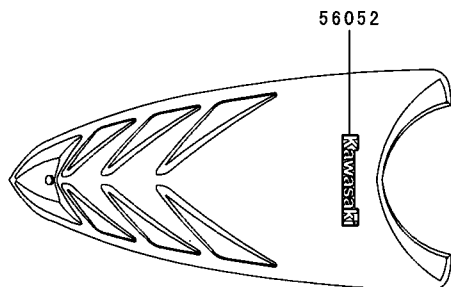

Ref. No.	Part No.	Description	Spec Code	Quantity-KSV700			
				'04	'05		
				A1	A2		
56052	56052-0060	MARK,KAWASAKI					1
56052A	56052-0061	MARK,RECOIL COVER,KAWASAKI					1
56052B	56052-0376	MARK,FUEL TANK COVER,KAWASAKI					2
56066	56066-1014	PATTERN,FR FENDER,LH					1
56066A	56066-1015	PATTERN,FR FENDER,RH					1
56066B	56066-1016	PATTERN,FUEL TANK COVER,LH					1
56066C	56066-1017	PATTERN,FUEL TANK COVER,RH					1

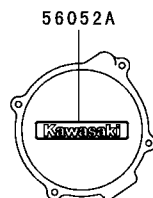
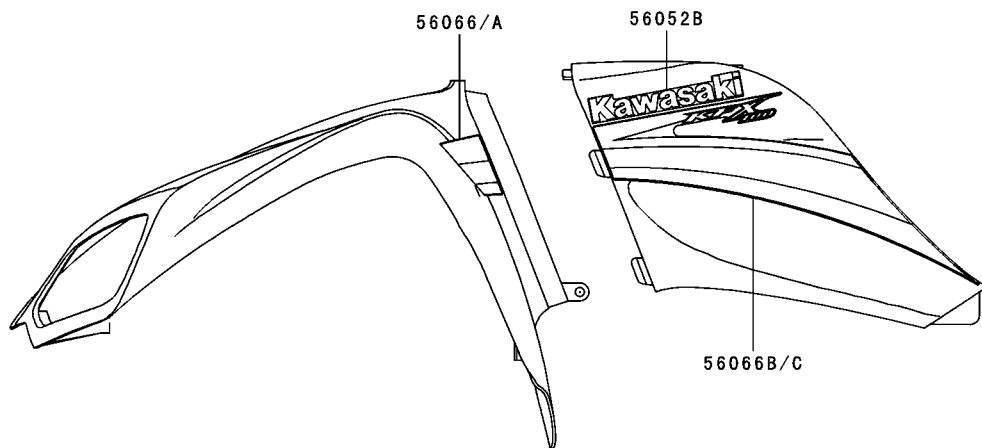

This catalog covers:

'04~'05 KSV700-A1/A2 Chassis

GRID NO.

G-10

This grid covers:

Manual(EU)

F2920

Ref. No.	Part No.	Description	Spec Code	Quantity-KSV700			
				'04	'05		
				A1	A2		
99923	99923-1593	OWNER'S MANUAL,GERMAN L-----	EU	1			
99947	99947-1353	OWNER'S MANUAL,FRENCH L-----	EU	1			
99972	99972-1048	OWNER'S MANUAL,SPANISH L-----	EU	1			
99976	99976-1182	OWNER'S MANUAL,MULTI L-----	EU	1			
99977	99977-1178	OWNER'S MANUAL,ENGLISH L-----	EU	1			
99982	99982-1031	OWNER'S MANUAL,PORTUGUESE L-----	EU	1			

Owner's Manual
(Local Procurement)

99923/99947/99972/99976/99977/99982

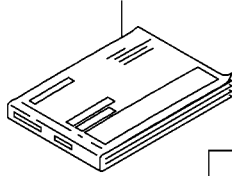

	Ref. No.	Language
'04)	(99923)	German
	(99947)	French
	(99972)	Spanish
	(99977)	English
	(99982)	Portuguese
'05)	(99976)	English
		French
		German

This catalog covers:

'04~'05 KSV700-A1/A2

GRID NO.

This grid covers:

L-13

Numerical Parts Index

Part No.	Grid No.	Part No.	Grid No.	Part No.	Grid No.	Part No.	Grid No.	Part No.	Grid No.	Part No.	Grid No.
11004-1384	B-3	12020-0004	B-8	130J0612	F-10	13271-1369	C-11	132Y0695	B-3	14091-1571	C-6
11005-1990	B-4	12020-1083	B-7	130J0614	E-7	13271-1887	E-3	132Y08110	C-5	15003-0019	C-7
11005-1992	B-4	12046-0021	B-10	130J0616	E-4	13271-1938	D-5	132Y0830	B-6	15011-0015	C-7
11008-0016	B-3	12046-1203	B-10	130J0616	E-9	13280-1096	C-8	132Y0875	C-5	15011-0016	C-7
11008-0017	B-3	12046-1203	B-9	130J0812	E-4	13280-1169	D-4	13310-1026	D-5	16007-1120	C-8
11008-0030	B-3	12046-1207	B-9	130J0814	F-10	13280-1198	F-11	14001-0028	C-5	16007-1178	B-7
11008-0031	B-3	12048-1176	B-10	130J0816	E-4	13280-1272	B-5	14001-1322	C-5	16007-1178	B-8
11009-1430	B-8	12048-1176	B-9	130J0822	E-5	13280-1273	B-5	14014-0006	C-5	16007-1203	C-3
11009-1865	B-6	12048-1177	B-10	130P0860	F-5	132G0630	F-7	14014-1148	B-10	16007-1221	C-3
11009-1894	B-6	12048-1177	B-9	130P1055	E-5	132G0640	E-5	14014-1148	B-9	16014-1105	C-8
11011-1659	B-5	12053-1440	C-10	130T0630	B-14	132H0616	C-12	14024-1551	F-14	16016-1117	C-8
11011-1660	B-5	12053-1441	B-10	130Y0635	B-13	132H0616	D-3	14031-0030	C-6	16017-1441	C-8
11012-1606	E-4	12053-1441	B-9	130Z0620	B-13	132H0625	B-3	14037-0017	C-14	16021-1223	C-7
11012-1854	C-14	12053-1442	B-10	130Z0620	C-4	132H0625	D-3	14041-1090	C-8	16030-1007	C-8
11013-0001	B-5	12053-1442	B-9	130Z0620	C-6	132H0625	F-11	14041-1136	B-13	16031-1097	C-8
11051-1870	F-12	12053-1443	B-10	13107-0029	B-10	132J0612	F-10	14044-0001	B-3	16035-1055	C-8
11052-1348	D-5	12053-1443	B-9	13107-1436	B-12	132J0612	F-7	14057-0001	D-5	16044-007	C-8
11052-1888	E-5	12053-1443	C-10	13107-1437	B-12	132J0616	C-12	14067-006	C-5	16065-1370	B-3
11052-1930	E-4	12053-1444	B-10	13107-1443	B-10	132J0616	E-3	14069-1051	C-6	16065-1371	B-3
11053-0104	B-13	12053-1444	B-9	13107-1443	B-9	132J0625	F-3	14073-1775	B-5	16085-1238	C-13
11053-0216	D-5	120P0610	B-10	13107-1444	B-10	132J0650	C-10	14073-1775	C-4	16087-1054	F-7
11053-0301	E-4	120P0610	B-9	13107-1444	B-9	132J0690	D-3	14073-1830	B-5	16097-1072	C-10
11060-1287	B-13	120P0628	C-11	13107-1507	E-6	132J0816	F-10	14073-1849	B-5	16115-0001	C-6
11060-1717	C-6	120P0816	C-13	13107-1514	B-9	132Y0612	B-3	14073-1850	C-4	16126-1226	C-8
11060-1956	B-13	120S0510	C-13	13107-1516	D-4	132Y0612	B-4	14073-1851	C-4	16126-4001	E-10
11060-1964	C-14	120S0614	B-10	13127-1282	B-12	132Y0612	B-5	14073-1853	C-4	16130-1058	C-10
11060-1965	B-4	120S0614	B-9	13139-1096	B-12	132Y0612	B-7	14075-1115	C-14	16142-0002	C-14
11060-1966	B-10	120Z0620	B-3	13151-1080	B-13	132Y0612	C-10	14090-1331	F-13	16142-1162	C-10
11060-1966	B-9	13001-1658	B-4	13168-0002	F-5	132Y0612	C-11	14090-1984	C-8	16146-1231	B-14
11060-1994	B-3	13002-1060	B-4	13168-0014	E-13	132Y0612	C-6	14091-0028	D-5	16154-2059	C-10
11061-0043	C-14	13008-1215	B-4	13168-1687	D-5	132Y0612	D-3	14091-0061-6Z	F-11	16154-2060	C-10
11061-0055	F-12	13025-0005	B-4	13168-1715	F-5	132Y06130	B-3	14091-0062-6Z	F-11	16160-1112	C-14
11061-1065	E-5	13029-0007	B-4	13194-1094	C-13	132Y0620	B-3	14091-0075-268	F-8	16160-1113	C-14
11061-1119	C-6	13031-0030	B-11	13216-0002	D-5	132Y0620	C-6	14091-0075-290	F-8	16160-1359	C-14
11065-1151	C-6	13042-1141	B-10	13234-1112	C-10	132Y0620	D-3	14091-0075-6W	F-8	16187-0021	C-8
11065-1152	B-3	13042-1141	B-9	13236-0031	B-13	132Y0630	B-10	14091-0089-6Z	F-8	18020-1307	F-7
11065-1252	C-6	13048-1088	D-4	13236-1377	B-13	132Y0630	B-13	14091-0090-6Z	F-8	18087-0006	B-6
11065-1260	D-5	13070-1352	B-13	13251-1143	B-11	132Y0630	B-3	14091-0095-6Z	F-12	18088-1222	B-6
12004-1146	B-7	13091-1992	C-13	13260-1868	B-12	132Y0630	B-4	14091-0096-268	E-9	180Y0620	B-6
12004-1146	B-8	130G0516	C-11	13260-1873	B-12	132Y0630	B-9	14091-0096-290	E-9	21003-0003	C-11
12005-1349	B-7	130G0620	E-13	13262-0002	B-12	132Y0630	C-10	14091-0096-6W	E-9	21007-1367	C-11
12005-1349	B-8	130G0625	C-4	13262-0014	D-4	132Y0630	C-11	14091-1196	C-7	21017-017	C-13
12009-1056	B-7	130G0816	D-6	13262-0015	B-12	132Y0630	C-13	14091-1422	D-5	21025-011	C-13
12009-1056	B-8	130J0610	E-9	13262-1052	B-12	132Y0630	C-6	14091-1425	E-5	21039-1063	C-13
12011-1051	B-7	130J0610	F-10	13262-1053	B-12	132Y0630	D-3	14091-1511-6D	E-8	21040-1057	C-13
12011-1051	B-8	130J0612	C-4	13271-0011	F-5	132Y0640	B-4	14091-1513	F-7	21066-1112	C-11
12016-1128	B-7	130J0612	E-13	13271-0058	E-8	132Y0640	C-5	14091-1524-6Z	E-8	21119-0032	C-12
12016-1128	B-8	130J0612	E-4	13271-0126	E-9	132Y0655	C-6	14091-1535	C-4	21121-1316	C-12
12016-1129	B-7	130J0612	E-8	13271-0127	E-9	132Y0665	C-5	14091-1538	C-6	21130-1071	C-12
12016-1129	B-8	130J0612	E-9	13271-1259	F-5	132Y0665	C-6	14091-1543	C-6	21163-1320	C-13

This catalog covers:

'04~'05 KSV700-A1/A2

GRID NO.

This grid covers:

L-14

Numerical Parts Index

Part No.	Grid No.	Part No.	Grid No.	Part No.	Grid No.	Part No.	Grid No.	Part No.	Grid No.	Part No.	Grid No.
21174-0001	C-14	27010-1294	F-5	39062-0002	C-14	42036-1376	E-6	482L8000	F-9	49125-0003	C-14
220B0308	F-7	27010-1313	C-10	39062-1816	C-14	42036-1378	E-14	49002-1097	B-3	49125-0007	C-14
220B0408	C-7	27010-1346	C-14	39062-1817	C-14	43001-0011-HN	E-13	49006-1040	F-3	51001-0013	F-7
220B0440	F-12	27010-1376	C-13	39062-1818	C-14	43015-1646	F-3	49006-1054	F-4	51023-1406	F-7
220C0520	F-5	27010-1421	F-14	39062-1858	C-14	43020-1056	F-3	49006-1055	F-4	51049-1128	F-7
220C0525	F-5	27010-1494	E-13	39062-1920	C-14	43022-1010	F-3	49006-1261	F-5	510A4200	C-11
220C0535	F-5	312C0600	F-6	39062-1921	C-14	43026-1074	F-3	49006-1292	B-5	52005-1082	G-3
220C0625	F-6	32033-1535	C-10	39062-1922	C-14	43028-1061	F-3	49006-1338	F-3	53004-0002	E-4
220D0408	C-8	32046-0006	E-4	39062-1923	C-14	43028-1085	C-8	49006-1353	C-7	53004-0009	E-4
220D0414	C-9	32085-1437	F-4	39062-1924	C-14	43034-1016	F-3	49006-1358	D-5	53066-0003-MA	F-8
221B0414	F-7	32085-1517	F-4	39074-0001	F-5	43044-1130	F-4	49016-1044	F-3	54005-1217	F-9
221B0616	C-5	32097-0002	E-4	39075-1062	F-5	43044-1131	F-4	49016-1213	F-11	54005-1218	F-9
223C0512	F-6	320H1000	E-3	39076-1076	C-13	43048-1083	F-4	49019-1055	C-7	54010-0005	B-13
223D0408	C-7	32153-1189	C-10	39111-0010	E-3	43049-1059	F-4	49019-1068	C-14	54010-1130	F-9
223D0408	F-9	32160-0028-HN	E-3	39111-1180	E-3	43049-1088	F-5	49022-0004	D-5	54010-1131	F-9
224C0612	D-3	32160-1800-HN	E-3	39112-1087	E-3	43049-1090	F-4	49022-1192	D-4	54012-0040	F-9
224C0614	E-3	32190-1315-HN	E-4	39112-1088	E-3	43049-1103	F-7	49022-1193	D-4	54012-0124	F-9
224D0445	F-11	32190-1316-HN	E-4	39114-0001	E-3	43056-1054	F-4	49030-1140	E-12	54017-1226	F-9
23005-1180	F-11	321H1200	E-6	39145-1135	C-4	43057-003	F-4	49030-1142	E-11	55020-0010-HN	F-10
23005-1181	F-11	33001-1585	E-5	39152-1088	B-14	43067-001	F-3	49031-1060	F-8	55020-0011	F-10
23007-1389	F-11	33032-1197	E-5	39186-0003	E-6	43078-0004	C-14	49040-1080	F-7	55020-0032	F-10
23007-1390	F-11	33032-1200	E-5	39186-0004	E-6	43080-5081-DJ	F-4	49047-1104	B-13	55020-0033	E-7
23016-0001	F-5	34028-1535-HN	E-7	39192-1132	B-3	43080-5082-DJ	F-4	49048-1087	B-14	55020-1799-6Z	E-7
23016-0002	F-5	35004-0014-268	E-8	39192-1133	B-3	43082-1255	F-4	49048-1088	B-14	55020-1800-6Z	E-7
23020-018	F-11	35004-0014-290	E-8	39193-1052	C-10	43082-1273	F-4	49048-1089	B-14	55020-1802	F-10
23024-1130	F-12	35004-0014-6W	E-8	39193-1053	C-10	43084-003	F-4	49048-1090	B-14	55020-1810-HN	F-10
23026-1230	F-12	35023-0010-268	E-9	39193-1054	C-10	43095-0030	F-3	49048-1091	B-14	550D1210	E-13
23036-0001	F-12	35023-0010-290	E-9	41009-0006	E-10	45014-0004-710	E-14	49048-1092	B-14	550D2015	E-13
26004-7501	F-13	35023-0010-6W	E-9	41009-0007	E-10	45014-0004-CC	E-14	49048-1093	B-14	550D2015	E-3
26006-1064	F-13	35063-0027	E-7	41009-0033	E-10	45014-0004-EH	E-14	49048-1094	B-14	550D2518	E-3
26011-0009	F-13	35063-0028	E-7	41009-0034	E-10	45014-0005-710	E-14	49048-1095	B-14	550D3025	E-6
26011-1741	F-13	35063-0033-HN	E-4	41025-0002	E-10	45014-0005-CC	E-14	49050-1081	B-14	550D3030	E-11
26011-1755	C-10	35063-0042	E-9	41025-0003	E-10	45014-0005-EH	E-14	49054-1055	C-14	550D4025	E-12
26011-1802	F-13	35063-0043	E-9	41046-1101	D-4	46003-0001-HN	F-5	49063-1055	C-14	551A0408	C-10
26011-1845	C-13	35063-0044	E-9	41046-1102	D-4	46012-1168	F-5	49065-1086	C-10	551A0408	D-3
26011-1847	F-13	35063-0045	E-9	41053-1099	E-5	46019-0006	F-5	49074-1055	C-3	554A0600	E-8
26012-1414	F-13	35063-0053	E-8	41055-003	E-13	46019-1122	F-5	49078-0014	B-8	556007-0001	G-3
26031-0011	F-13	35063-0064	E-8	41068-0003	D-5	46075-1210	F-5	49078-1073	B-7	56008-1007	G-3
27002-1086	F-13	35063-0067	E-8	41072-007	E-5	46076-1258	F-5	49085-1067	C-14	56030-0018	G-4
27005-1267	F-14	35063-0139	E-8	41080-1483	D-5	46091-1848	F-5	49093-0010	B-14	56030-0018	G-5
27008-1041	F-14	35063-0140	E-8	41080-1484	D-5	46092-1208	F-3	49093-1076	B-14	56033-0001	G-4
27008-1042	F-14	35063-1253	E-8	41080-1534	F-4	46092-1217	F-5	49094-0005	C-3	56033-0001	G-5
27008-1043	F-14	39007-1307-HN	E-6	41080-1538	D-5	461K0500	C-13	49106-1293	B-6	56033-0002	G-4
27008-1044	F-14	39007-1309-HN	E-6	410B0600	E-13	480J1400	B-10	49107-1226	B-6	56033-0002	G-5
27008-1132	F-14	39007-1311-HN	E-6	410B0800	B-10	480J2800	D-4	49116-1126	C-7	56033-0021	C-5
27008-1133	F-14	39007-1312-HN	E-6	410B0800	B-9	481J2400	E-6	49116-1190	C-14	56033-0023	G-4
27008-1134	F-14	39012-1055	E-4	411B0600	E-3	481J3700	C-5	49118-0001	B-10	56033-0023	G-5
27008-1135	F-14	39031-1070	C-5	411F0800	E-3	482J5000	B-10	49118-0001	B-9	56033-1263	G-4
27010-1170	F-3	39045-1072	C-4	411F0800	E-4	482J5000	B-9	49118-0002	B-10	56033-1263	G-5
27010-1202	C-14	39060-0006	C-14	42036-0012	E-14	482J6000	C-10	49118-0002	B-9	56040-1157	G-4

This catalog covers:

'04~'05 KSV700-A1/A2

GRID NO.

This grid covers:

L-15

Numerical Parts Index

Part No.	Grid No.	Part No.	Grid No.	Part No.	Grid No.	Part No.	Grid No.	Part No.	Grid No.	Part No.	Grid No.
56040-1157	G-5	56070-1292	G-5	92005-1376	C-7	92022-1132	C-13	92037-147	C-14	92049-1223	E-6
56040-1261	G-4	59011-0003	C-3	92005-1385	C-7	92022-125	F-11	92037-147	C-6	92049-1228	C-6
56052-0060	G-6	59026-1159	C-11	92005-1387	C-4	92022-125	F-8	92037-1505	B-5	92049-1452	C-5
56052-0060	G-7	59041-0001	C-14	92009-1435	F-5	92022-1380	C-7	92037-1505	C-7	92049-1528	C-3
56052-0060	G-8	59071-3717	F-7	92009-1458	F-3	92022-1458	C-13	92037-1505	F-7	92049-1529	D-4
56052-0060	G-9	59256-1069	C-14	92009-1549	C-8	92022-1582	E-13	92037-1539	C-7	92049-1537	E-5
56052-0061	G-6	59266-0001	E-3	92009-1551	C-8	92022-1690	E-13	92037-1589	C-14	92049-1538	E-5
56052-0061	G-7	59266-1011	E-6	92009-1621	B-5	92022-1720	B-3	92037-1610	C-7	92049-1575	C-5
56052-0061	G-8	59266-1139	E-6	92009-1621	C-14	92022-1837	F-5	92037-1730	C-5	92049-1576	C-6
56052-0061	G-9	59301-1070	B-14	92009-1621	E-7	92022-1838	F-5	92039-1229	E-8	92049-1578	F-5
56052-0102	G-7	59302-0001	C-3	92009-1621	E-8	92022-1943	E-13	92039-3763	G-4	92049-1611	E-3
56052-0103	G-6	59302-0002	C-3	92009-1621	F-12	92022-304	B-4	92039-3763	G-5	92049-1612	E-11
56052-0376	G-9	59302-0003	B-14	92009-1621	F-8	92022-304	C-14	92043-076	C-10	92049-1613	E-11
56052-0377	G-8	59302-1106	B-14	92009-1654	F-11	92022-3742	E-3	92043-1013	E-13	92055-0004	D-5
56066-0237	G-7	59441-1173-6D	F-5	92009-1664	F-11	92026-0034	C-3	92043-1263	B-14	92055-086	B-10
56066-0238	G-7	600A1000	B-13	92009-1667	D-4	92026-1415	B-12	92043-1263	B-3	92055-086	B-9
56066-0239	G-7	601A6000	C-5	92009-1667	D-5	92026-1565	C-3	92043-1263	C-6	92055-1136	C-5
56066-0240	G-7	601A6004	C-5	92009-1841	F-5	92026-1568	B-12	92043-1356	F-4	92055-1136	C-6
56066-0241	G-6	601A6011	D-6	92009-1897	F-14	92026-1569	C-3	92043-1506	C-5	92055-1136	D-5
56066-0242	G-6	601A6304	C-5	92009-1914	D-4	92026-1570	C-3	92043-1567	E-5	92055-1146	C-6
56066-0243	G-6	601B6206	D-4	92009-1936	E-5	92026-1603	B-14	92043-1617	D-5	92055-1215	C-11
56066-0244	G-6	670B2016	B-3	92009-1959	F-5	92026-1617	C-3	92043-1688	B-14	92055-1276	C-13
56066-1014	G-9	670B2016	E-5	92013-009	B-7	92026-1629	B-12	92043-4009	B-3	92055-1279	C-14
56066-1015	G-9	670B2020	D-3	92013-009	B-8	92026-1630	B-12	92043-4009	B-4	92055-1279	C-6
56066-1016	G-9	670D1505	C-10	92015-1094	F-11	92027-1166	E-4	92045-0012	C-5	92055-1295	B-3
56066-1017	G-9	670D1507	C-10	92015-1174	E-3	92027-1354	E-4	92045-1190	C-5	92055-1370	C-13
56066-1018	G-8	670D1509	B-7	92015-1193	B-13	92027-162	F-11	92045-1190	D-4	92055-1381	C-13
56066-1019	G-8	670D2014	C-6	92015-1229	E-5	92027-1817	E-3	92045-1207	D-4	92055-1589	C-8
56066-1020	G-8	670D2016	C-10	92015-1233	F-3	92027-1847	F-7	92045-1246	C-6	92055-1630	C-4
56066-1021	G-8	671D2530	C-3	92015-1259	C-7	92027-1964	F-12	92045-1389	C-5	92055-1632	C-6
56070-0004	G-4	671D2550	C-3	92015-1311	B-11	92028-1961	B-11	92045-1391	D-5	92055-1644	B-3
56070-0007	G-4	671D2585	D-4	92015-1410	E-13	92028-1962	B-11	92045-1403	C-6	92055-1664	F-7
56070-0007	G-5	671D2585	D-6	92015-1428	E-6	92028-1963	B-11	92045-1427	E-5	92055-2185	C-6
56070-0022	G-5	702A07035	C-6	92015-1433	B-9	92028-1975	B-14	92045-3705	E-11	92057-1536	B-10
56070-0037	G-5	92001-1693	E-14	92015-1476	C-13	92028-1986	F-5	92045-3721	E-11	92057-1536	B-9
56070-1108	G-4	92001-1703	B-5	92015-1596	F-5	92033-1037	B-12	92046-1046	E-6	92057-1537	B-10
56070-1108	G-5	92001-1728	F-3	92015-1597	E-14	92033-1039	B-10	92046-1118	C-5	92057-1537	B-9
56070-1110	G-4	92001-1980	B-11	92015-1603	E-7	92033-1039	B-9	92046-1143	C-5	92057-1538	C-10
56070-1110	G-5	92001-1998	C-7	92015-1603	F-8	92033-1207	B-4	92046-1239	E-14	92059-1736	C-7
56070-1170	G-4	92002-1250	E-3	92015-1617	E-14	92033-1262	E-6	92046-1277	C-5	92063-1013	C-8
56070-1170	G-5	92002-1323	F-3	92015-1678	E-8	92033-1317	C-3	92046-1278	B-12	92063-1014	C-8
56070-1179	G-4	92002-1349	E-3	92015-1678	F-12	92033-1320	D-4	92046-1279	B-12	92063-1015	C-8
56070-1269	G-4	92002-1840	E-14	92015-1692	F-11	92037-093	F-7	92048-0002	C-13	92063-1016	C-8
56070-1269	G-5	92002-1888	F-3	92015-1757	F-11	92037-093	F-9	92048-1090	C-13	92063-1017	C-8
56070-1271	G-4	92002-1894	F-3	92015-1765	E-11	92037-1104	D-5	92049-0012	D-5	92063-1069	C-8
56070-1271	G-5	92004-1217	B-3	92015-1829	F-5	92037-1163	F-13	92049-0013	D-5	92063-1072	C-8
56070-1286	G-4	92005-1112	C-7	92016-061	B-7	92037-1201	C-7	92049-1030	E-5	92063-1074	C-8
56070-1286	G-5	92005-1337	C-14	92016-061	B-8	92037-1460	B-5	92049-1108	E-14	92063-1075	C-8
56070-1291	G-4	92005-1369	C-6	92019-008	B-14	92037-1461	F-7	92049-1218	B-7	92063-1076	C-8
56070-1292	G-4	92005-1375	C-7	92022-1065	E-6	92037-147	B-5	92049-1218	B-8	92064-0005	C-8

This catalog covers:

'04~'05 KSV700-A1/A2

GRID NO.

L-16

This grid covers:

Numerical Parts Index

Part No.	Grid No.	Part No.	Grid No.	Part No.	Grid No.	Part No.	Grid No.	Part No.	Grid No.	Part No.	Grid No.
92065-023	D-5	92081-1896	F-11	92145-1553	D-5	92153-1200	B-9	92172-0062	F-8	92200-1505	C-3
92065-058	B-13	92092-1054	E-14	92150-1243	C-13	92153-1200	C-10	92172-0063	F-11	92200-1508	B-7
92065-097	C-5	92092-1079	E-14	92150-1302	B-3	92153-1272	E-4	92172-0078	F-5	92200-1508	B-8
92066-0011	C-6	92093-0007	F-7	92150-1384	E-6	92160-1007	D-3	92172-1061	F-12	92200-1558	F-5
92066-0012	C-6	92093-0010	E-14	92150-1420	F-5	92160-1053	F-12	92180-1307	D-4	92200-1559	F-5
92066-1174	C-5	92093-1046	C-8	92150-1719	E-14	92160-1451	D-3	92180-1308	D-4	92200-1578	F-8
92066-1211	B-5	92093-1247	E-4	92150-1771	F-4	92160-1594	B-5	92180-1309	D-4	92200-1595	E-10
92066-1220	E-3	92093-1522	B-5	92150-1987	C-11	92160-1990	B-6	92180-1310	D-4	92200-1634	B-14
92066-1220	E-4	92093-1569	B-5	92151-1209	B-3	92161-0027	F-7	92180-1311	D-4	92210-0085	D-3
92066-1289	B-3	92093-1570	B-5	92151-1305	B-5	92161-0048	E-4	92180-1312	D-4	92210-0086	D-3
92066-1303	D-5	92104-002	G-3	92151-1392	E-11	92161-0059	F-8	92180-1313	D-4	92210-1109	F-14
92066-1534	E-5	92107-005	G-3	92151-1392	E-12	92161-0060	F-8	92180-1314	D-4	92210-1150	E-4
92066-1550	F-5	92107-1053	G-3	92151-1393	B-14	92161-0061	F-8	92180-1349	D-4	92210-1184	E-3
92066-1580	C-4	92110-1116	G-3	92151-1413	E-14	92161-0090	F-8	92180-1350	D-4	92210-1242	B-6
92066-2196	B-8	92110-1129	G-3	92151-1686	C-4	92161-1160	E-8	92180-1351	D-4	92210-1294	D-4
92068-006	B-3	92110-1140	G-3	92151-1687	B-13	92170-1491	D-3	92180-1352	D-4	92210-1294	D-6
92069-063	F-12	92110-1152	G-3	92151-1688	D-4	92170-1492	C-7	92180-1417	D-5	92210-1325	E-10
92069-1114	F-11	92110-1153	G-3	92151-1689	C-5	92170-1492	D-3	92180-1418	D-5	92210-1367	C-3
92070-1209	C-12	92110-1173	G-3	92151-1699	B-13	92170-1493	D-3	92180-1419	D-5	92210-1381	E-12
92071-0008	E-9	92116-1001	E-5	92151-1781	C-10	92170-1497	D-3	92180-1420	D-6	92210-1385	E-3
92071-1128	F-13	92122-1209	C-3	92151-1793	F-4	92170-1514	B-5	92180-1421	D-6	92210-1386	E-3
92071-1131	E-8	92139-0042	E-14	92151-1909	D-5	92170-1514	C-11	92180-1422	D-6	99923-1593	G-10
92072-0006	E-4	92140-1064	D-5	92151-1917	B-3	92170-1514	D-3	92180-1423	D-6	99947-1353	G-10
92072-0032	E-4	92143-1057	F-8	92151-1944	B-6	92170-1722	B-3	92180-1424	D-6	99972-1048	G-10
92072-030	E-4	92143-1087	C-4	92152-0061	E-4	92170-1763	C-4	92180-1425	D-6	99976-1182	G-10
92072-030	F-13	92143-1087	E-7	92152-1152	B-6	92170-1763	D-5	92180-1426	D-6	99977-1178	G-10
92072-030	F-9	92143-1087	E-8	92152-1176	F-5	92170-1764	B-5	92180-1427	D-6	99982-1031	G-10
92072-056	D-5	92143-1087	E-9	92152-1240	E-5	92170-1764	C-4	92180-1428	D-6		
92072-1197	C-4	92143-1087	F-12	92152-1293	E-14	92170-1925	C-11	92191-0014	D-6		
92072-1226	E-4	92143-1087	F-8	92152-1332	C-4	92170-2043	D-5	92191-0017	C-7		
92072-1239	E-4	92143-1353	C-4	92152-1332	C-6	92171-0066	E-3	92191-0018	C-7		
92072-1239	F-13	92143-1353	D-3	92152-1346	F-8	92171-0094	E-6	92191-0034	F-7		
92072-1239	F-9	92143-1857	C-10	92152-1356	E-5	92171-0095	E-6	92191-1251	C-7		
92072-1438	F-7	92145-0021	B-14	92152-1455	E-6	92171-0329	C-5	92191-1449	C-5		
92075-1123	C-4	92145-0097	C-8	92152-1456	E-3	92171-1095	F-5	92191-1494	B-5		
92075-1435	E-8	92145-1227	C-8	92152-1461	E-11	92171-1230	F-9	92191-1531	B-5		
92075-157	F-10	92145-1260	F-4	92152-1462	E-11	92171-1329	C-10	92191-1666	F-7		
92075-1690	F-11	92145-1297	B-13	92152-1463	E-11	92171-1330	B-6	92191-1672	C-7		
92075-1787	E-4	92145-1298	D-4	92152-1467	C-11	92171-1357	B-6	92191-1673	C-7		
92075-1787	F-7	92145-1299	B-13	92153-0361	F-7	92171-1383	D-5	92191-1674	C-7		
92075-1853	C-7	92145-1300	D-5	92153-0394	D-5	92171-1394	B-5	92191-1740	C-5		
92075-209	C-14	92145-1303	B-10	92153-0395	D-5	92171-1423	F-13	92191-1773	F-7		
92075-261	F-10	92145-1303	B-9	92153-0397	D-5	92171-1424	F-13	92192-0020	F-7		
92077-1129	F-8	92145-1313	E-5	92153-0408	E-4	92171-1522	B-5	92192-0057	C-5		
92081-112	C-10	92145-1346	F-11	92153-0427	E-7	92171-1542	E-3	92200-1171	E-11		
92081-1358	F-5	92145-1354	F-4	92153-0456	D-3	92171-1543	E-3	92200-1240	B-12		
92081-1565	E-13	92145-1392	F-5	92153-0627	F-3	92171-1554	C-4	92200-1251	G-4		
92081-1620	C-7	92145-1450	C-8	92153-1052	B-5	92171-1559	F-13	92200-1251	G-5		
92081-1621	C-7	92145-1462	C-3	92153-1068	C-7	92172-0005	D-3	92200-1351	B-12		
92081-1622	C-7	92145-1534	E-13	92153-1200	B-10	92172-0058	B-13	92200-1504	B-14		

This catalog covers:

'04~'05 KSV700-A1/A2

GRID NO.

B-16

This grid covers:

Part Name Index

Air Cleaner.....	B-5
Brake Pedal.....	E-13
Cables.....	F-9
Camshaft(s)(A1).....	B-9
Camshaft(s)(A2).....	B-10
Carburetor.....	C-7
Carburetor Parts.....	C-8/C-9
Chassis Electrical Equipment.....	F-13
Converter Cover.....	C-4
Crankcase.....	C-5
Crankshaft.....	B-11
Cylinder.....	B-4
Cylinder Head.....	B-3
Decals(Green)(A1).....	G-7
Decals(Green)(A2).....	G-9
Decals(Orange)(A1)(AS).....	G-6
Decals(Orange)(A2)(EU).....	G-8
Drive Belt.....	C-4
Drive Converter.....	B-14
Drive Shaft-Rear.....	D-5/D-6
Driven Converter.....	C-3
Engine Cover(s).....	C-6
Footrests.....	E-7
Frame.....	E-3
Frame Fittings.....	E-4
Front Bevel Gear.....	D-4
Front Brake.....	F-4
Front Fender(s).....	E-8
Front Hub.....	E-11
Front Master Cylinder.....	F-3

Fuel Tank.....	F-7
Gear Change Mechanism.....	B-13
Generator.....	C-11
Guard(s).....	F-10
Handlebar.....	F-5/F-6
Headlight(s).....	F-11
Ignition Switch.....	F-14
Ignition System.....	C-12
Labels(A1).....	G-4
Labels(A2).....	G-5
Manual(EU).....	G-10
Muffler(s).....	B-6
Oil Pump.....	C-10
Owner's Tools.....	G-3
Piston(s).....	B-4
Radiator.....	C-14/D-3
Rear Fender(s).....	E-9
Rear Hub.....	E-12
Seat.....	F-8
Shock Absorber(s).....	E-14
Starter Motor.....	C-13
Suspension.....	E-6
Swingarm.....	E-5
Taillight(s).....	F-12
Tensioner(A1).....	B-9
Tensioner(A2).....	B-10
Tires.....	E-10
Transmission.....	B-12
Valve(s)(A1).....	B-7
Valve(s)(A2).....	B-8

This catalog covers:

'04~'05 KSV700-A1/A2

GRID NO.

C-16

This grid covers:

Part Name Index

Air Cleaner.....	B-5
Brake Pedal.....	E-13
Cables.....	F-9
Camshaft(s)(A1).....	B-9
Camshaft(s)(A2).....	B-10
Carburetor.....	C-7
Carburetor Parts.....	C-8/C-9
Chassis Electrical Equipment.....	F-13
Converter Cover.....	C-4
Crankcase.....	C-5
Crankshaft.....	B-11
Cylinder.....	B-4
Cylinder Head.....	B-3
Decals(Green)(A1).....	G-7
Decals(Green)(A2).....	G-9
Decals(Orange)(A1)(AS).....	G-6
Decals(Orange)(A2)(EU).....	G-8
Drive Belt.....	C-4
Drive Converter.....	B-14
Drive Shaft-Rear.....	D-5/D-6
Driven Converter.....	C-3
Engine Cover(s).....	C-6
Footrests.....	E-7
Frame.....	E-3
Frame Fittings.....	E-4
Front Bevel Gear.....	D-4
Front Brake.....	F-4
Front Fender(s).....	E-8
Front Hub.....	E-11
Front Master Cylinder.....	F-3

Fuel Tank.....	F-7
Gear Change Mechanism.....	B-13
Generator.....	C-11
Guard(s).....	F-10
Handlebar.....	F-5/F-6
Headlight(s).....	F-11
Ignition Switch.....	F-14
Ignition System.....	C-12
Labels(A1).....	G-4
Labels(A2).....	G-5
Manual(EU).....	G-10
Muffler(s).....	B-6
Oil Pump.....	C-10
Owner's Tools.....	G-3
Piston(s).....	B-4
Radiator.....	C-14/D-3
Rear Fender(s).....	E-9
Rear Hub.....	E-12
Seat.....	F-8
Shock Absorber(s).....	E-14
Starter Motor.....	C-13
Suspension.....	E-6
Swingarm.....	E-5
Taillight(s).....	F-12
Tensioner(A1).....	B-9
Tensioner(A2).....	B-10
Tires.....	E-10
Transmission.....	B-12
Valve(s)(A1).....	B-7
Valve(s)(A2).....	B-8

This catalog covers:

'04~'05 KSV700-A1/A2

GRID NO.

D-16

This grid covers:

Part Name Index

Air Cleaner.....	B-5
Brake Pedal.....	E-13
Cables.....	F-9
Camshaft(s)(A1).....	B-9
Camshaft(s)(A2).....	B-10
Carburetor.....	C-7
Carburetor Parts.....	C-8/C-9
Chassis Electrical Equipment.....	F-13
Converter Cover.....	C-4
Crankcase.....	C-5
Crankshaft.....	B-11
Cylinder.....	B-4
Cylinder Head.....	B-3
Decals(Green)(A1).....	G-7
Decals(Green)(A2).....	G-9
Decals(Orange)(A1)(AS).....	G-6
Decals(Orange)(A2)(EU).....	G-8
Drive Belt.....	C-4
Drive Converter.....	B-14
Drive Shaft-Rear.....	D-5/D-6
Driven Converter.....	C-3
Engine Cover(s).....	C-6
Footrests.....	E-7
Frame.....	E-3
Frame Fittings.....	E-4
Front Bevel Gear.....	D-4
Front Brake.....	F-4
Front Fender(s).....	E-8
Front Hub.....	E-11
Front Master Cylinder.....	F-3

Fuel Tank.....	F-7
Gear Change Mechanism.....	B-13
Generator.....	C-11
Guard(s).....	F-10
Handlebar.....	F-5/F-6
Headlight(s).....	F-11
Ignition Switch.....	F-14
Ignition System.....	C-12
Labels(A1).....	G-4
Labels(A2).....	G-5
Manual(EU).....	G-10
Muffler(s).....	B-6
Oil Pump.....	C-10
Owner's Tools.....	G-3
Piston(s).....	B-4
Radiator.....	C-14/D-3
Rear Fender(s).....	E-9
Rear Hub.....	E-12
Seat.....	F-8
Shock Absorber(s).....	E-14
Starter Motor.....	C-13
Suspension.....	E-6
Swingarm.....	E-5
Taillight(s).....	F-12
Tensioner(A1).....	B-9
Tensioner(A2).....	B-10
Tires.....	E-10
Transmission.....	B-12
Valve(s)(A1).....	B-7
Valve(s)(A2).....	B-8

This catalog covers:

'04~'05 KSV700-A1/A2

GRID NO.

E-16

This grid covers:

Part Name Index

Air Cleaner.....	B-5
Brake Pedal.....	E-13
Cables.....	F-9
Camshaft(s)(A1).....	B-9
Camshaft(s)(A2).....	B-10
Carburetor.....	C-7
Carburetor Parts.....	C-8/C-9
Chassis Electrical Equipment.....	F-13
Converter Cover.....	C-4
Crankcase.....	C-5
Crankshaft.....	B-11
Cylinder.....	B-4
Cylinder Head.....	B-3
Decals(Green)(A1).....	G-7
Decals(Green)(A2).....	G-9
Decals(Orange)(A1)(AS).....	G-6
Decals(Orange)(A2)(EU).....	G-8
Drive Belt.....	C-4
Drive Converter.....	B-14
Drive Shaft-Rear.....	D-5/D-6
Driven Converter.....	C-3
Engine Cover(s).....	C-6
Footrests.....	E-7
Frame.....	E-3
Frame Fittings.....	E-4
Front Bevel Gear.....	D-4
Front Brake.....	F-4
Front Fender(s).....	E-8
Front Hub.....	E-11
Front Master Cylinder.....	F-3

Fuel Tank.....	F-7
Gear Change Mechanism.....	B-13
Generator.....	C-11
Guard(s).....	F-10
Handlebar.....	F-5/F-6
Headlight(s).....	F-11
Ignition Switch.....	F-14
Ignition System.....	C-12
Labels(A1).....	G-4
Labels(A2).....	G-5
Manual(EU).....	G-10
Muffler(s).....	B-6
Oil Pump.....	C-10
Owner's Tools.....	G-3
Piston(s).....	B-4
Radiator.....	C-14/D-3
Rear Fender(s).....	E-9
Rear Hub.....	E-12
Seat.....	F-8
Shock Absorber(s).....	E-14
Starter Motor.....	C-13
Suspension.....	E-6
Swingarm.....	E-5
Taillight(s).....	F-12
Tensioner(A1).....	B-9
Tensioner(A2).....	B-10
Tires.....	E-10
Transmission.....	B-12
Valve(s)(A1).....	B-7
Valve(s)(A2).....	B-8

This catalog covers:

'04~'05 KSV700-A1/A2

GRID NO.

F-16

This grid covers:

Part Name Index

Air Cleaner.....	B-5
Brake Pedal.....	E-13
Cables.....	F-9
Camshaft(s)(A1).....	B-9
Camshaft(s)(A2).....	B-10
Carburetor.....	C-7
Carburetor Parts.....	C-8/C-9
Chassis Electrical Equipment.....	F-13
Converter Cover.....	C-4
Crankcase.....	C-5
Crankshaft.....	B-11
Cylinder.....	B-4
Cylinder Head.....	B-3
Decals(Green)(A1).....	G-7
Decals(Green)(A2).....	G-9
Decals(Orange)(A1)(AS).....	G-6
Decals(Orange)(A2)(EU).....	G-8
Drive Belt.....	C-4
Drive Converter.....	B-14
Drive Shaft-Rear.....	D-5/D-6
Driven Converter.....	C-3
Engine Cover(s).....	C-6
Footrests.....	E-7
Frame.....	E-3
Frame Fittings.....	E-4
Front Bevel Gear.....	D-4
Front Brake.....	F-4
Front Fender(s).....	E-8
Front Hub.....	E-11
Front Master Cylinder.....	F-3

Fuel Tank.....	F-7
Gear Change Mechanism.....	B-13
Generator.....	C-11
Guard(s).....	F-10
Handlebar.....	F-5/F-6
Headlight(s).....	F-11
Ignition Switch.....	F-14
Ignition System.....	C-12
Labels(A1).....	G-4
Labels(A2).....	G-5
Manual(EU).....	G-10
Muffler(s).....	B-6
Oil Pump.....	C-10
Owner's Tools.....	G-3
Piston(s).....	B-4
Radiator.....	C-14/D-3
Rear Fender(s).....	E-9
Rear Hub.....	E-12
Seat.....	F-8
Shock Absorber(s).....	E-14
Starter Motor.....	C-13
Suspension.....	E-6
Swingarm.....	E-5
Taillight(s).....	F-12
Tensioner(A1).....	B-9
Tensioner(A2).....	B-10
Tires.....	E-10
Transmission.....	B-12
Valve(s)(A1).....	B-7
Valve(s)(A2).....	B-8

This catalog covers:

'04~'05 KSV700-A1/A2

GRID NO.

G-16

This grid covers:

Part Name Index

Air Cleaner.....	B-5
Brake Pedal.....	E-13
Cables.....	F-9
Camshaft(s)(A1).....	B-9
Camshaft(s)(A2).....	B-10
Carburetor.....	C-7
Carburetor Parts.....	C-8/C-9
Chassis Electrical Equipment.....	F-13
Converter Cover.....	C-4
Crankcase.....	C-5
Crankshaft.....	B-11
Cylinder.....	B-4
Cylinder Head.....	B-3
Decals(Green)(A1).....	G-7
Decals(Green)(A2).....	G-9
Decals(Orange)(A1)(AS).....	G-6
Decals(Orange)(A2)(EU).....	G-8
Drive Belt.....	C-4
Drive Converter.....	B-14
Drive Shaft-Rear.....	D-5/D-6
Driven Converter.....	C-3
Engine Cover(s).....	C-6
Footrests.....	E-7
Frame.....	E-3
Frame Fittings.....	E-4
Front Bevel Gear.....	D-4
Front Brake.....	F-4
Front Fender(s).....	E-8
Front Hub.....	E-11
Front Master Cylinder.....	F-3

Fuel Tank.....	F-7
Gear Change Mechanism.....	B-13
Generator.....	C-11
Guard(s).....	F-10
Handlebar.....	F-5/F-6
Headlight(s).....	F-11
Ignition Switch.....	F-14
Ignition System.....	C-12
Labels(A1).....	G-4
Labels(A2).....	G-5
Manual(EU).....	G-10
Muffler(s).....	B-6
Oil Pump.....	C-10
Owner's Tools.....	G-3
Piston(s).....	B-4
Radiator.....	C-14/D-3
Rear Fender(s).....	E-9
Rear Hub.....	E-12
Seat.....	F-8
Shock Absorber(s).....	E-14
Starter Motor.....	C-13
Suspension.....	E-6
Swingarm.....	E-5
Taillight(s).....	F-12
Tensioner(A1).....	B-9
Tensioner(A2).....	B-10
Tires.....	E-10
Transmission.....	B-12
Valve(s)(A1).....	B-7
Valve(s)(A2).....	B-8