

This catalog covers:  
**'08 KSF450 B8F**

GRID NO. This grid covers:  
**A-1** Title



## PARTS CATALOG

**'08 KSF450 B8F**

**(KFX450R)**

---

Publications .....	A-2
Model Identification .....	A-4
Engine .....	B-1
Chassis .....	D-1

---

© Kawasaki Heavy Industries, Ltd. 2007

Engine No. Location:  
LH crankcase, lower rear

---

<b>Year &amp; Model</b>	<b>'08 KSF450B8F</b>
<b>Color</b>	1. Colored Plastic Bright White (266) 2. Lime Green (777)
<b>VIN No. Range</b>	JKASFGB1√8B500001 ~ (Australia only) JKASF450BBB600001 ~ (Europe only)
<b>Engine No. Range</b>	SF450BE500001 ~

This catalog covers:  
**'08 KSF450 B8F**

GRID NO. **A-2** This grid covers:  
**Publications**

Year & Model	Owner's Manual	A&P Manual		Service Manual		Microfiche
		General	Supplement	Basic	Supplement	
<b>2008 KSF450B8F</b>	99977-1300 99986-1429(Australia only)	99931-1480-01		99924-1386-01		99912-1481-01



This catalog covers:  
**'08 KSF450 B8F**

GRID NO.  
**A-4**

This grid covers:  
**Model I.D. '08 KSF450B8F**

---

# KSF450B8F

Left Side View



Right Side View

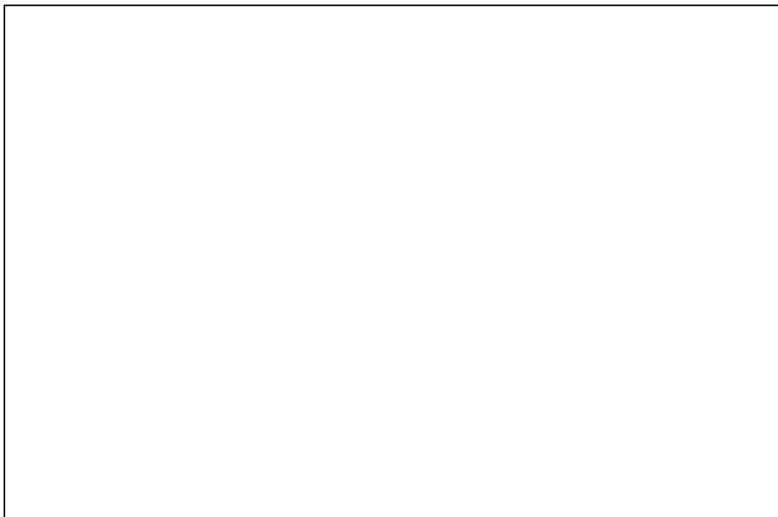





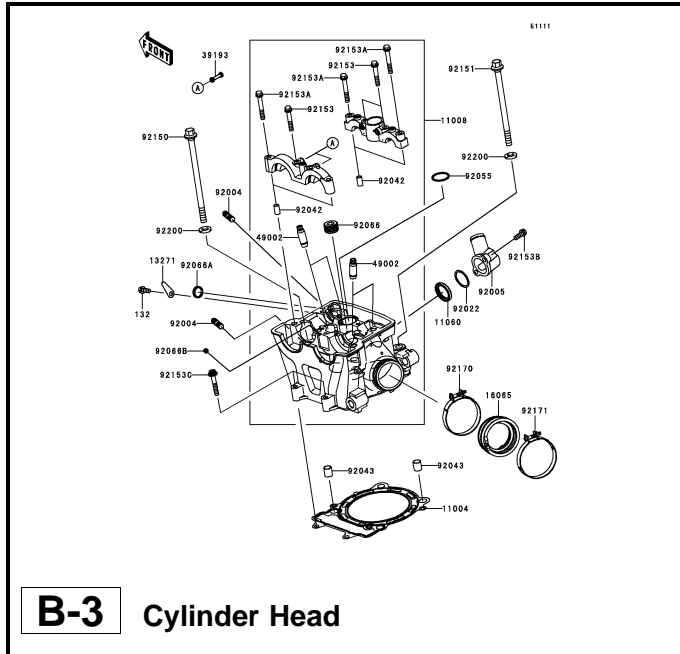

**B-3** Cylinder Head

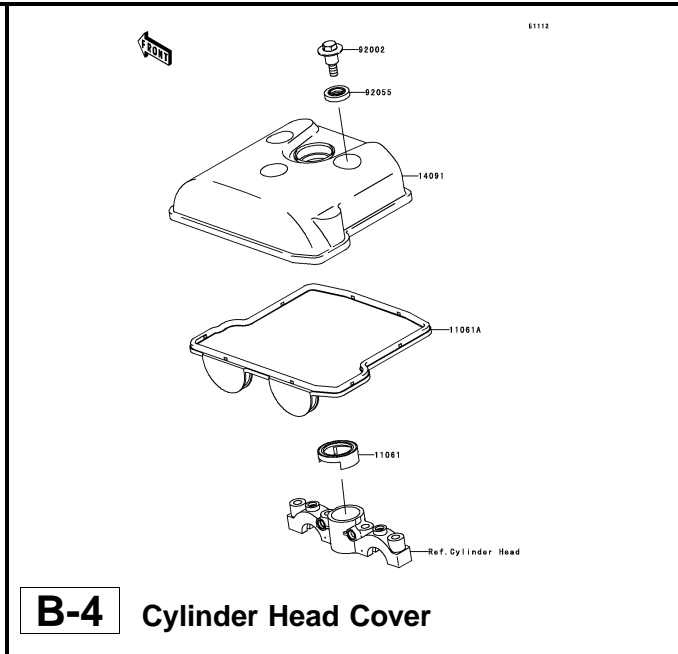

**B-4** Cylinder Head Cover

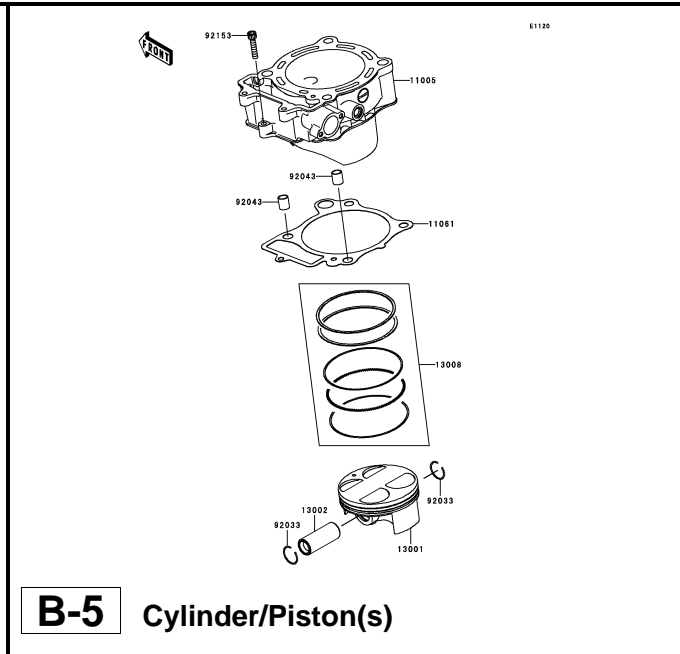

**B-5** Cylinder/Piston(s)

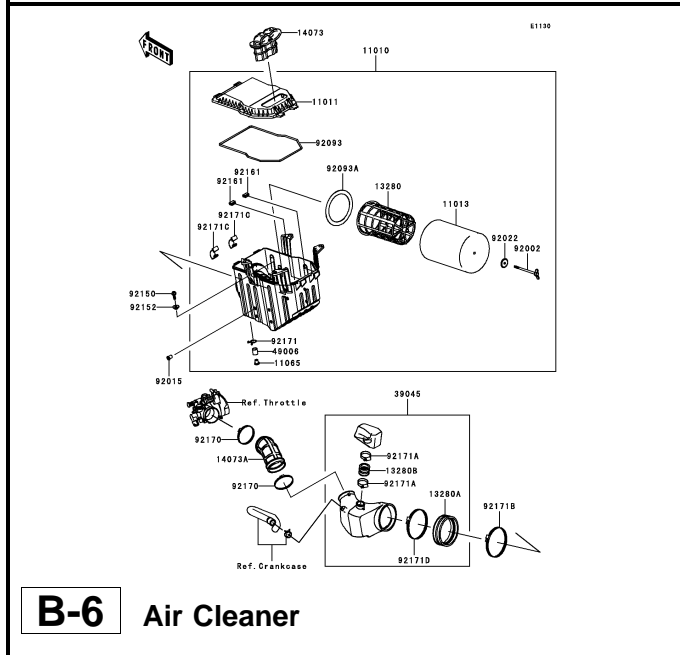

**B-6** Air Cleaner

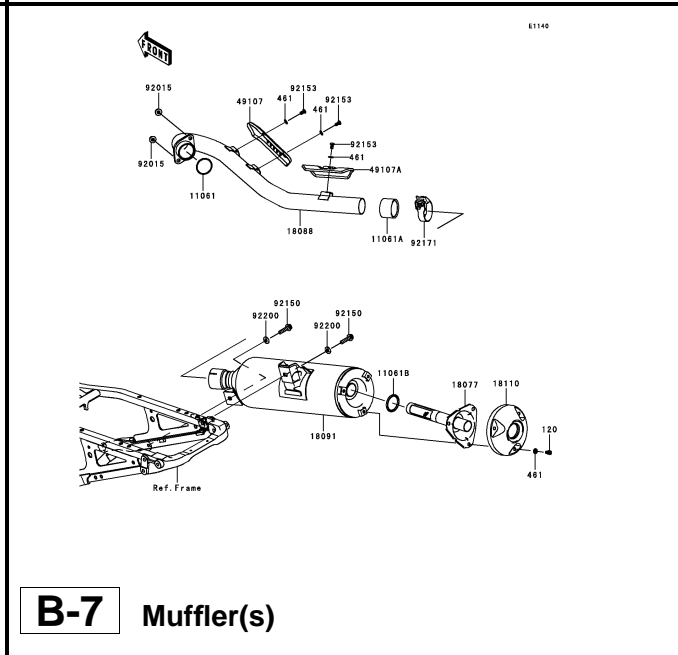

**B-7** Muffler(s)

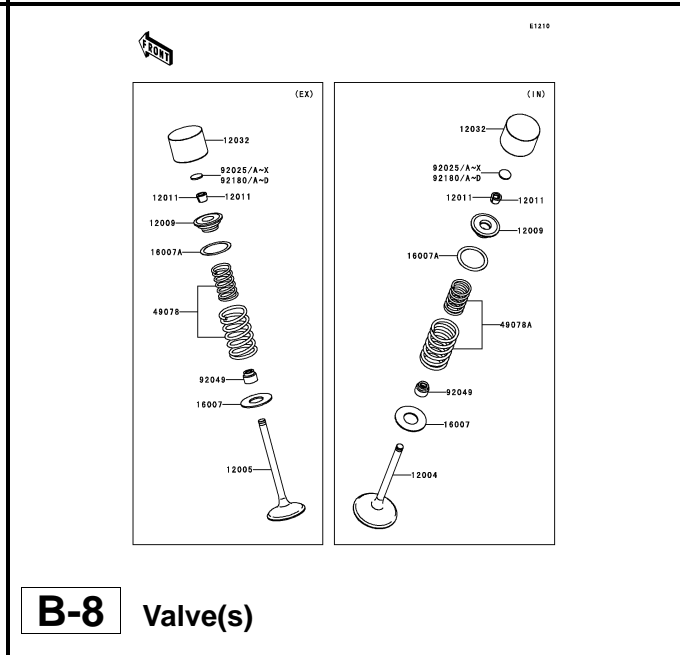

**B-8** Valve(s)





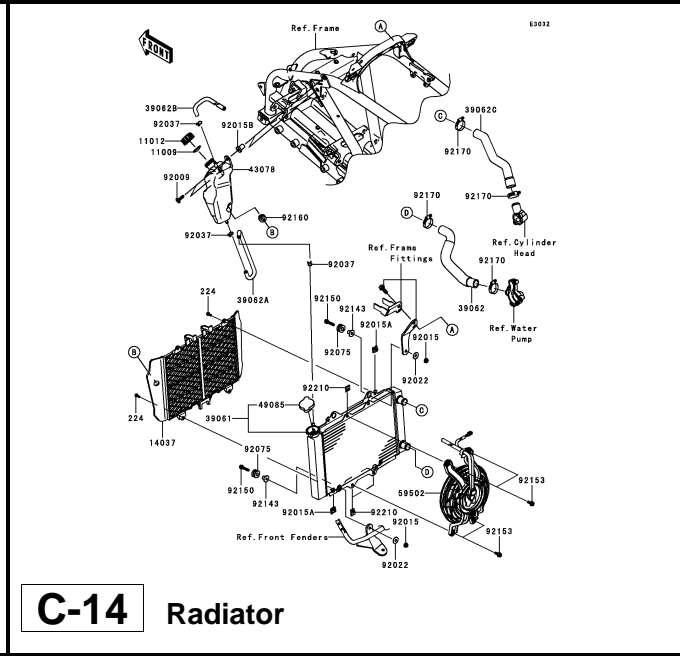
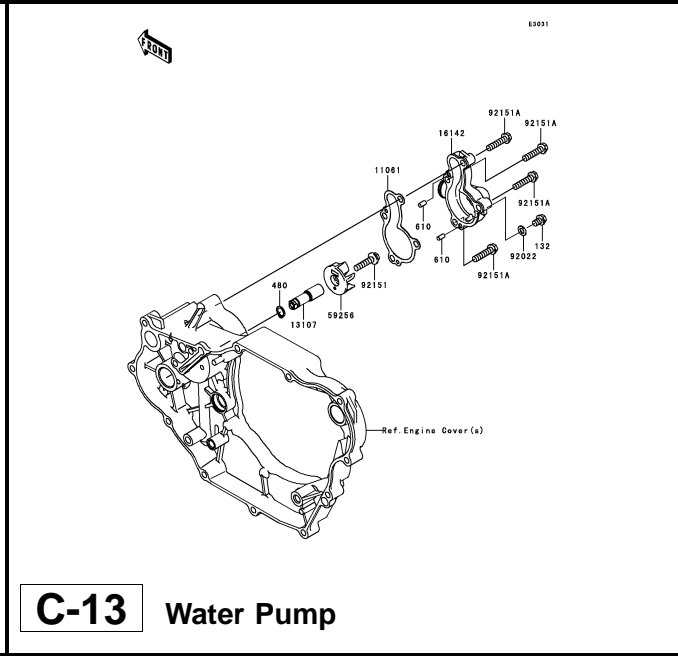
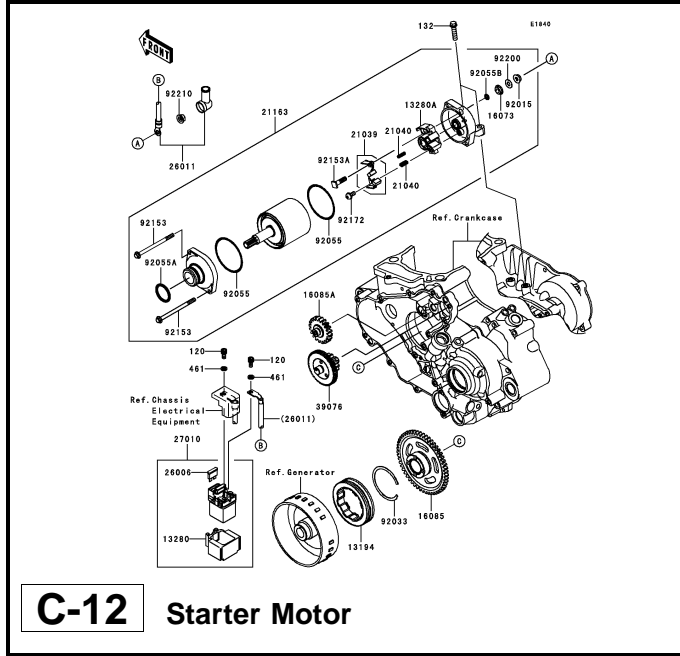
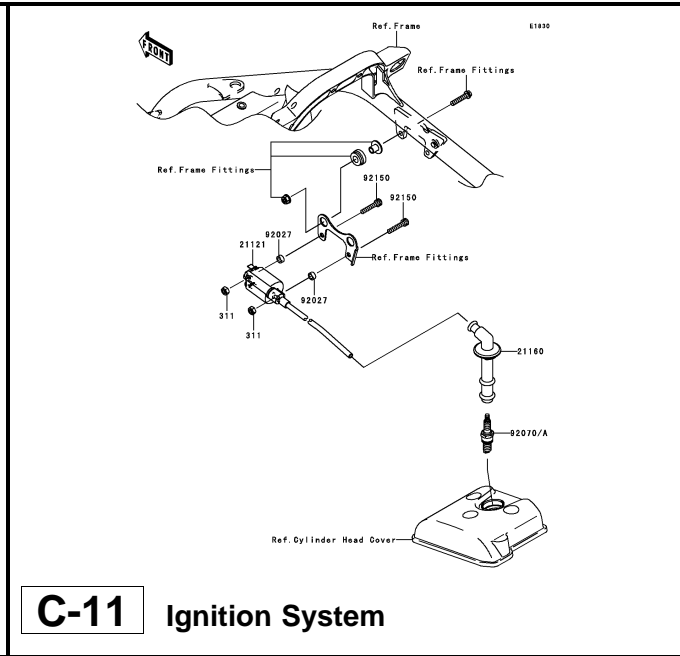
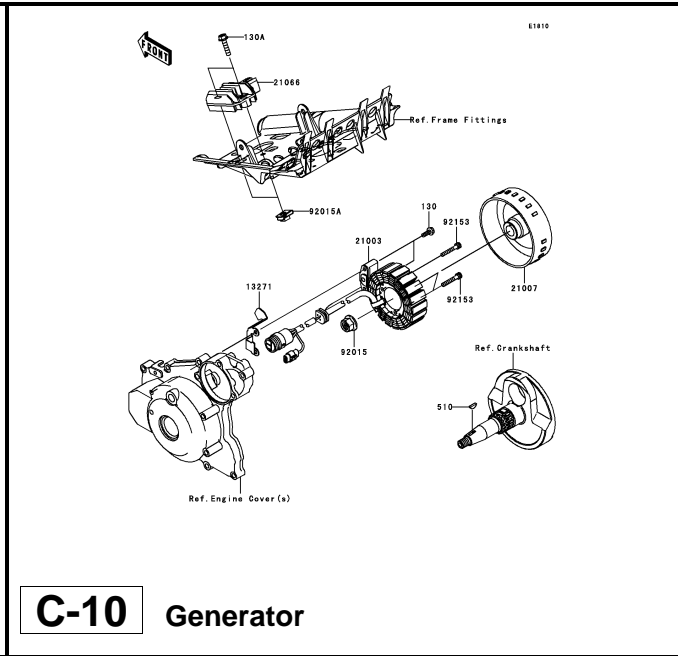
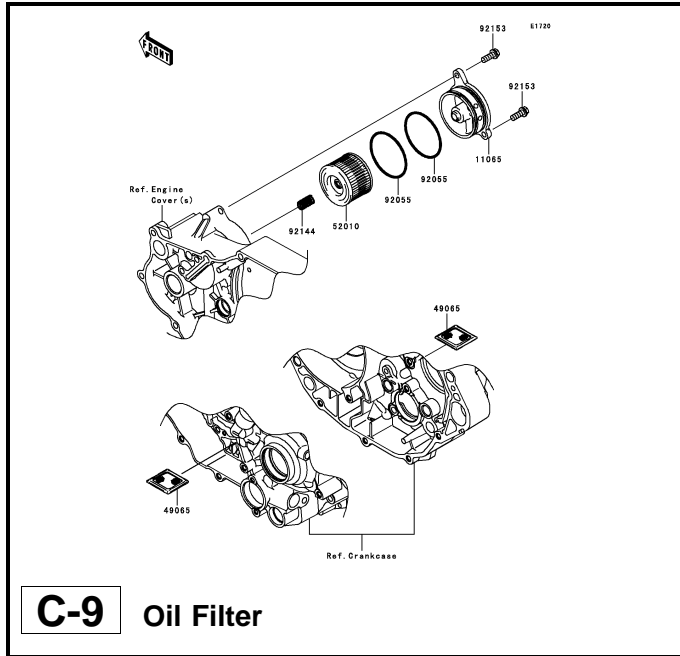



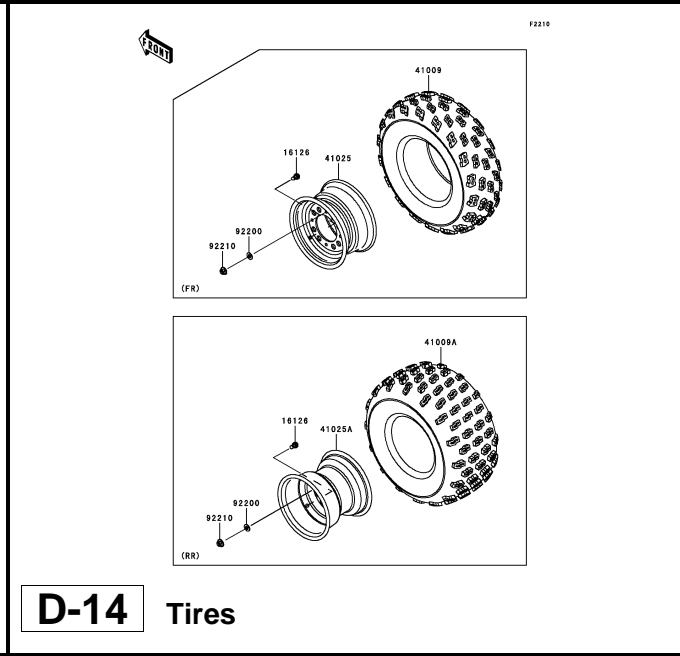
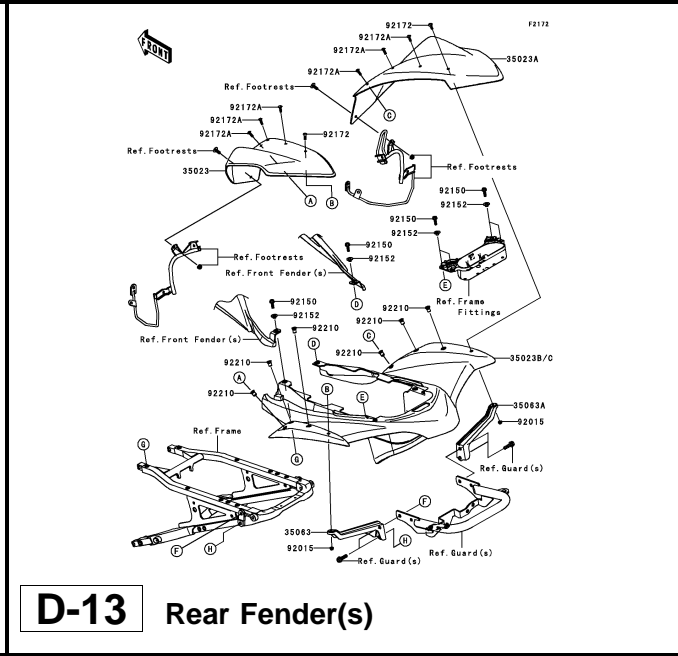
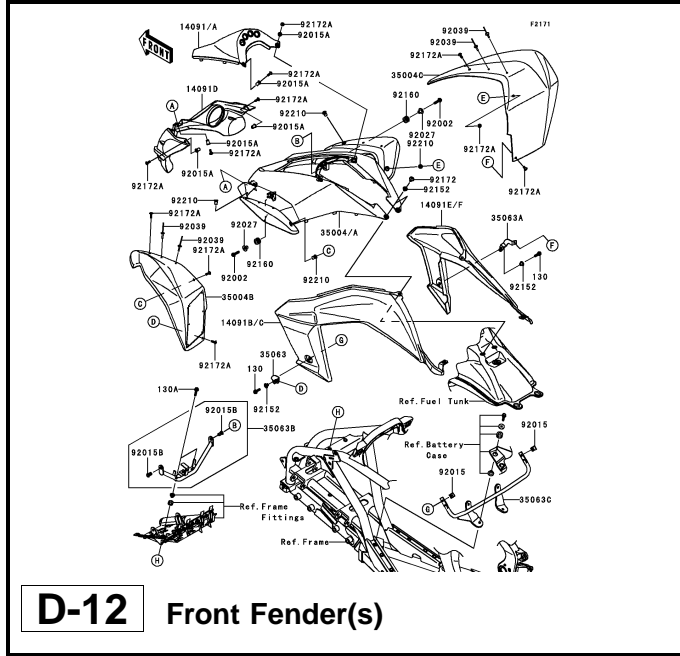
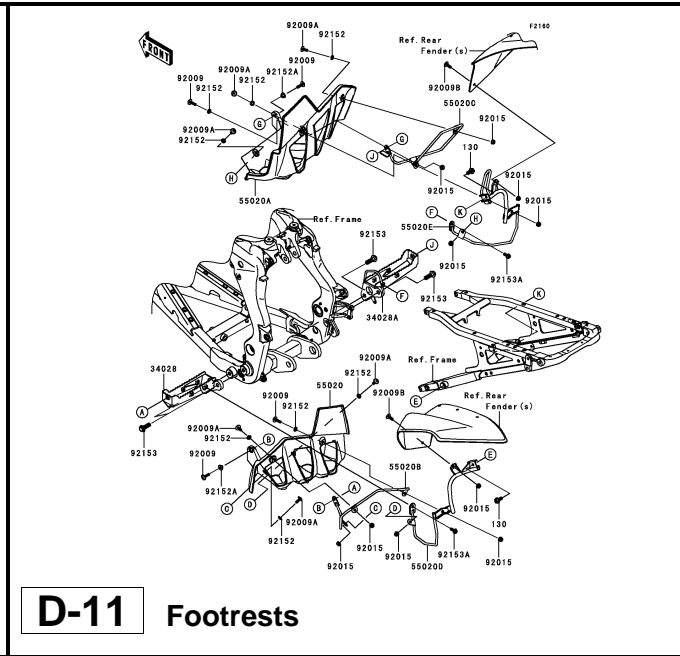
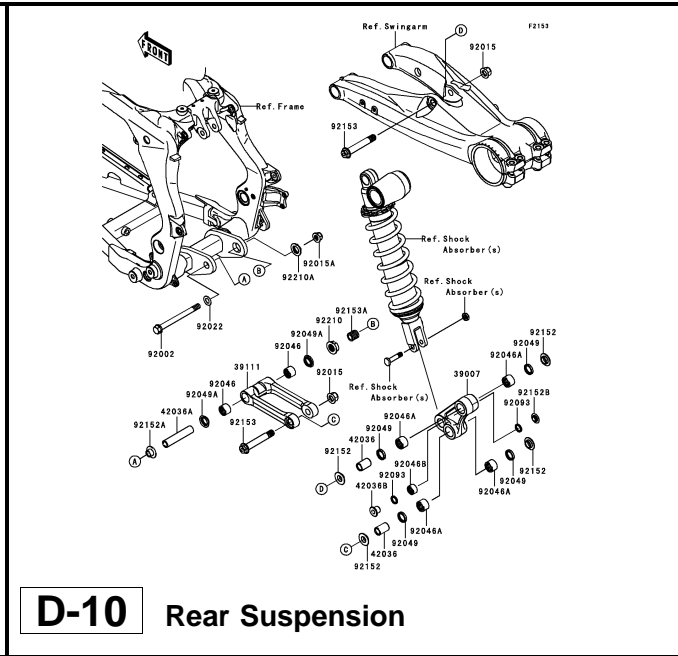
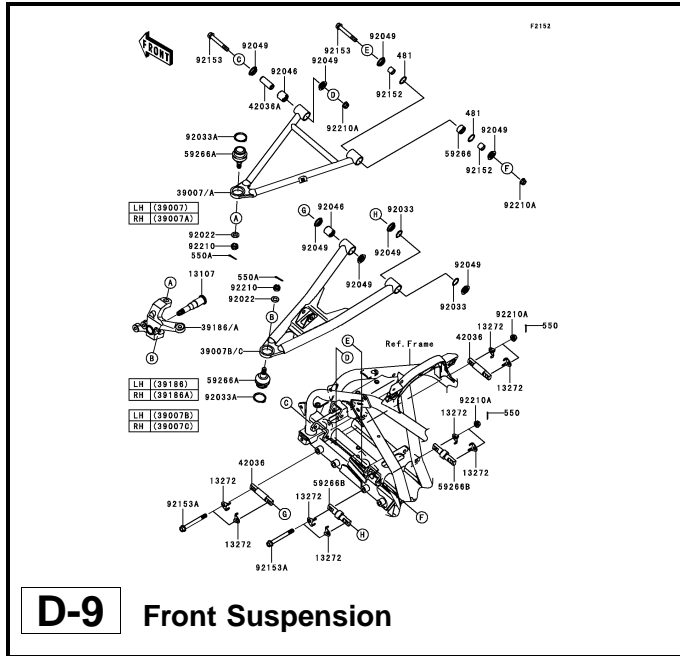



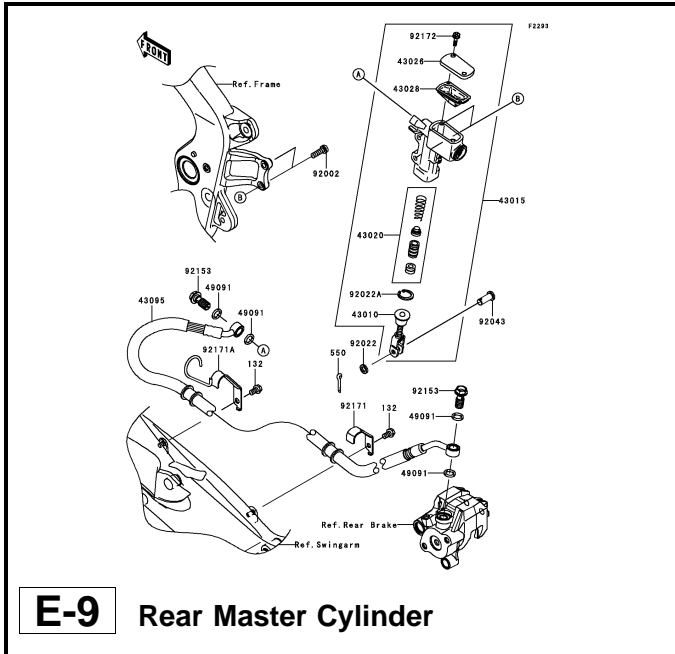

**E-9** Rear Master Cylinder

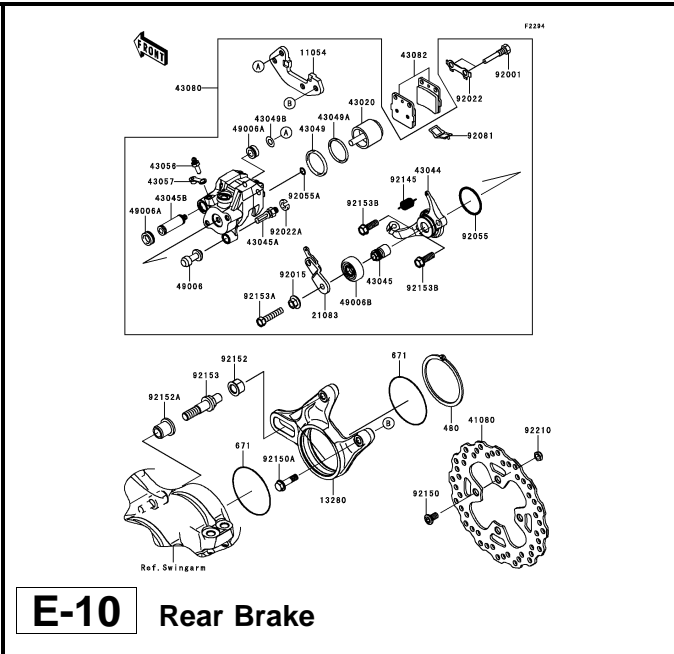

**E-10** Rear Brake

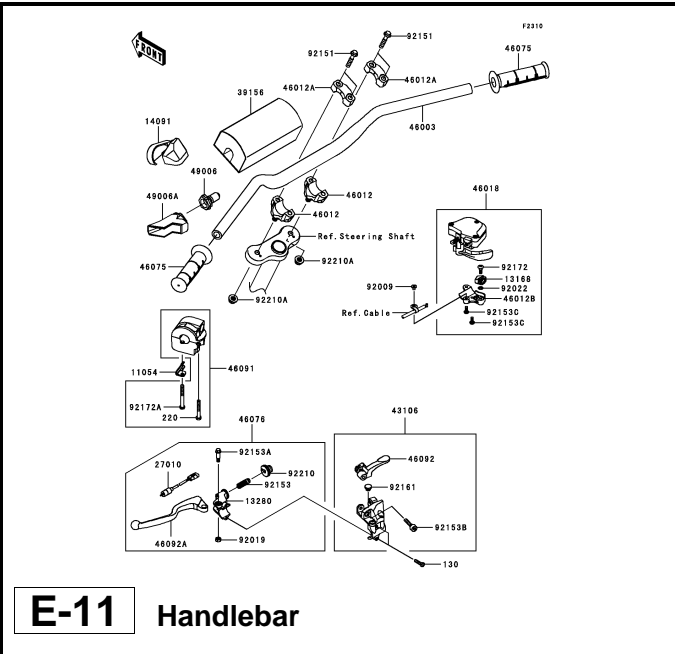

**E-11** Handlebar

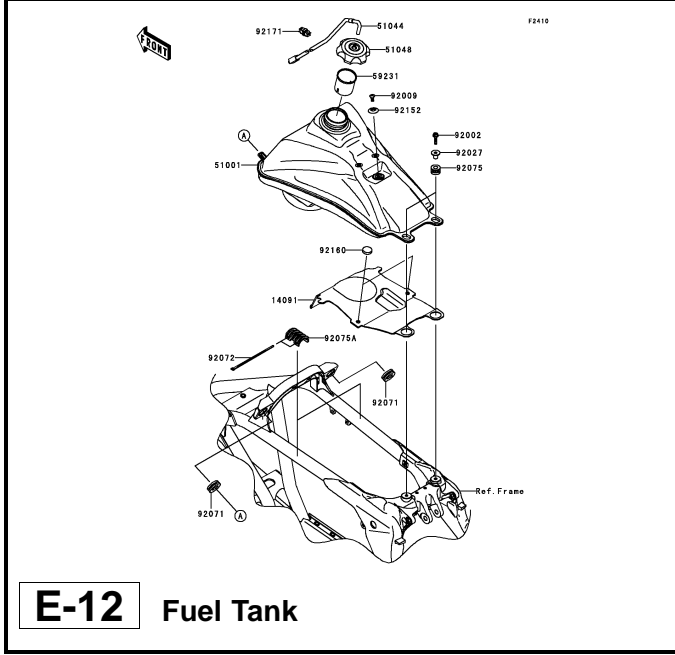

**E-12** Fuel Tank

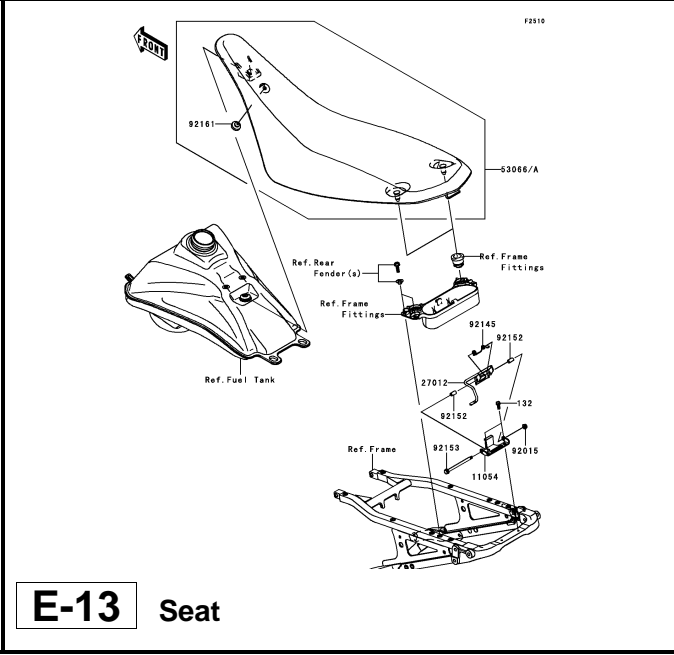

**E-13** Seat

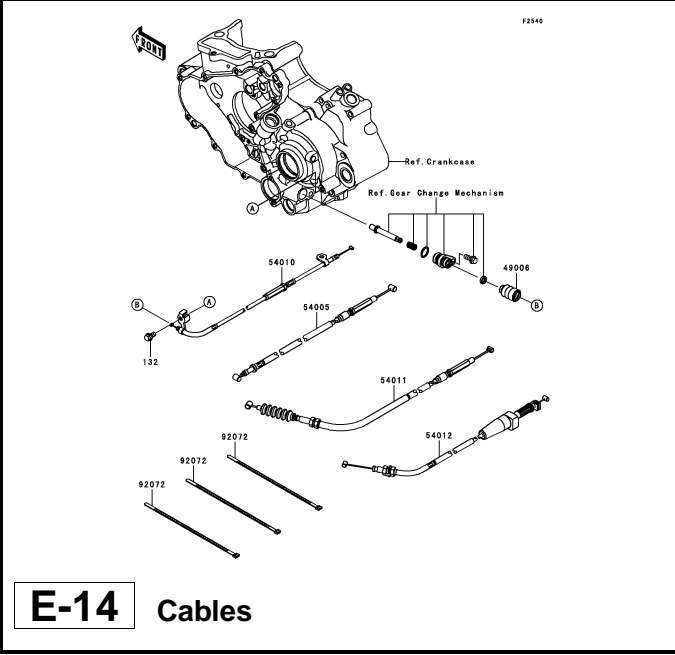

**E-14** Cables

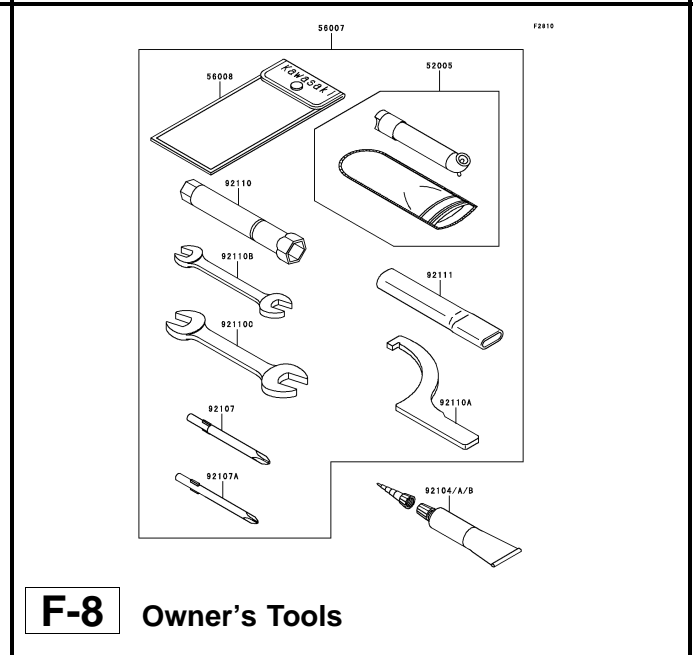
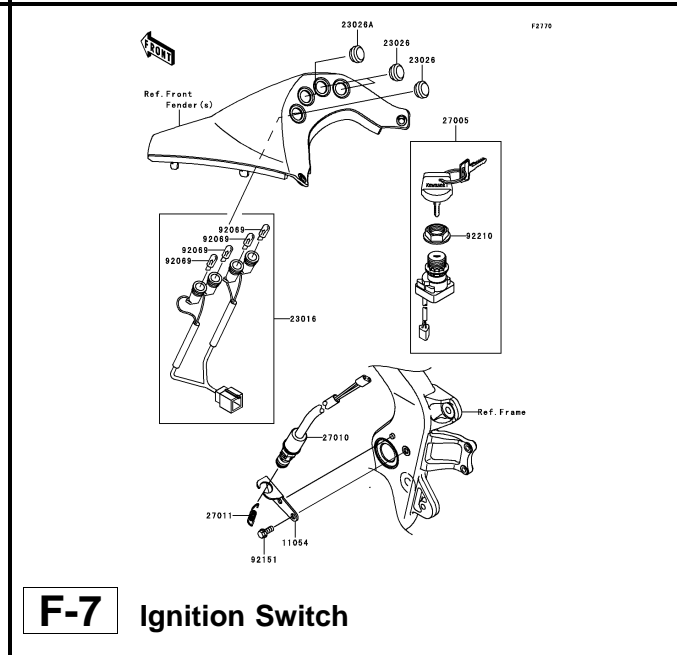
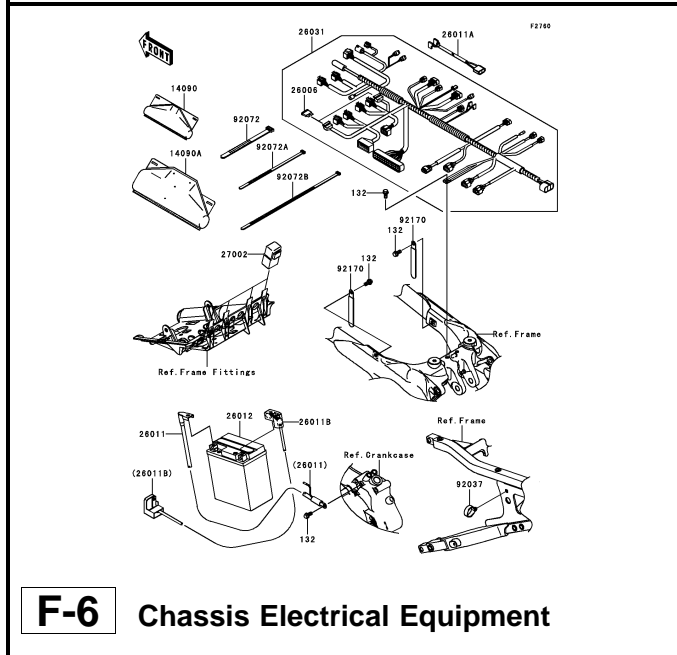
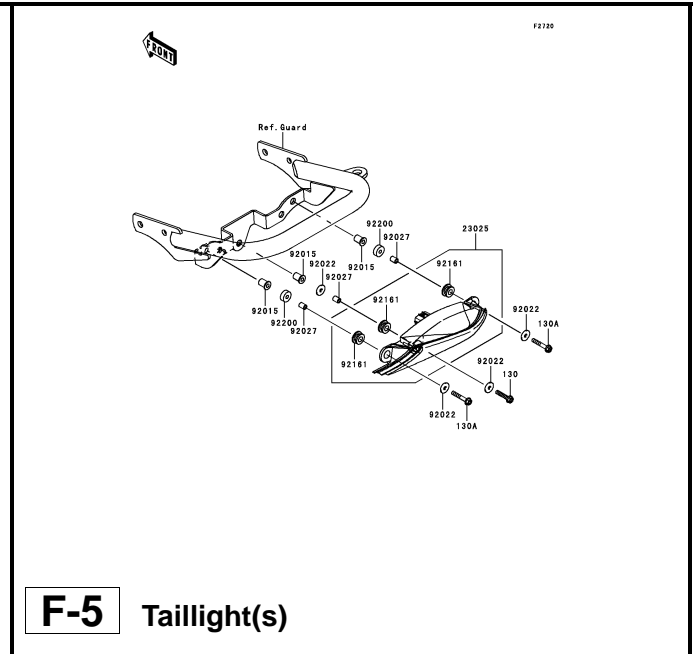
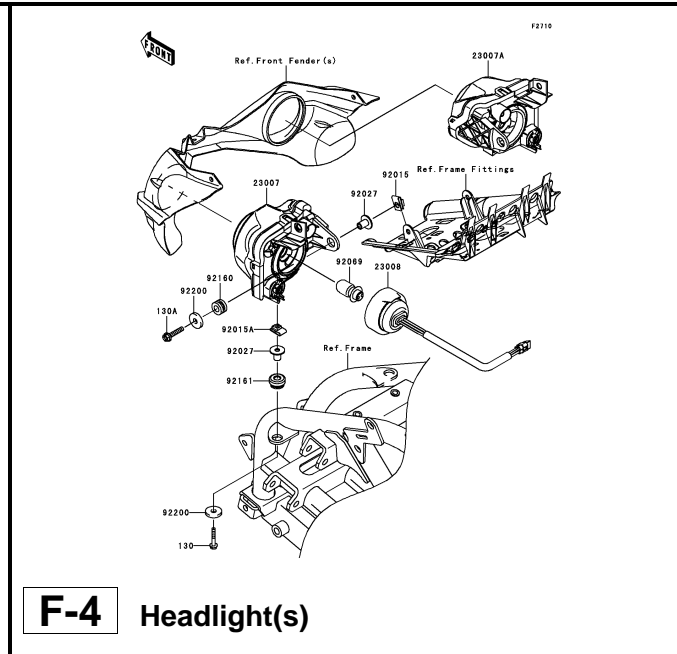
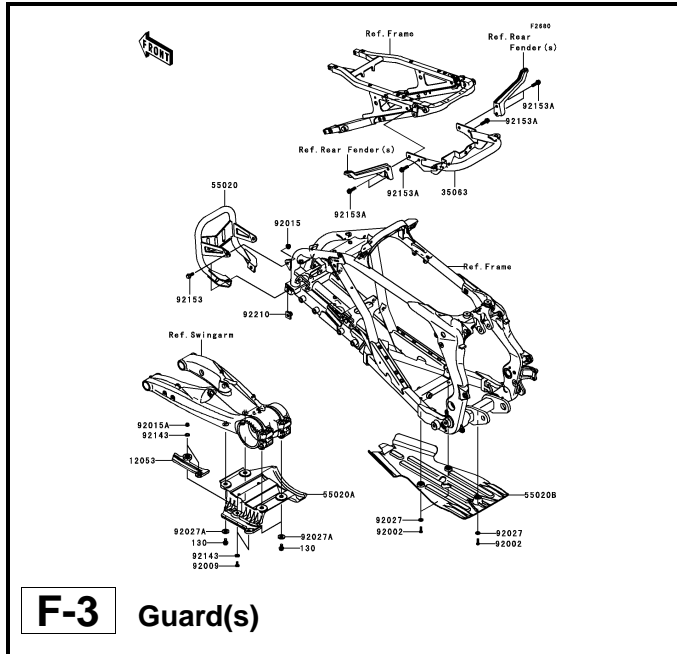

F2480

Labels: (AS) 56040, (EU) 56070A, (EU) 56070B, (EU) 56070C, 56030, 56030B/C, 56033, 56070, 56071B, 92200, 92039, 56071A, 56071C/D, 56040A/B, 56070/C, Ref. Front Fender(s), Ref. Rear Fender(s), Ref. Air Cleaner.

**F-9 Labels**

F2481

Labels: (Top View) 56052C, White, 56052A, Ref. Front Fender(s) Black, Ref. Rear Fender(s), 56052B, (RH Side) Black 56052B, Ref. Front Fender(s), Ref. Rear Fender(s), 56052, White, 56067/A, 56052D, White, Ref. Front Fender(s), 56067B/C, Black, Ref. Rear Fender(s).

**F-10 Decals(White)(EU)**

F2881A

Labels: (Top View) 56052A, White, Green, 56052B, Ref. Front Fender(s) Black, Ref. Rear Fender(s), 56052C, Ref. Front Fender(s), (RH Side) Black 56052B, Ref. Rear Fender(s), Ref. Front Fender(s), 56052, Green, 56067/A, 56052D, Green, Ref. Front Fender(s), 56067B/C, Black, Ref. Rear Fender(s).

**F-11 Decals(Green)**

F2920

Owner's Manual (Local Procurement)  
 99923  
 99947  
 99972  
 99984  
 99992

Ref. No.	Language
(99923)	German
(99947)	French
(99972)	Spanish
(99984)	Dutch
(99992)	Italian

Service Manual  
 99953  
 99954  
 99956

Ref. No.	Language
(99953)	German
(99954)	French
(99956)	Spanish

A&P Manual  
 99946  
 99950  
 99952

Ref. No.	Language
(99946)	German
(99950)	French
(99952)	Spanish

**F-12 Manual(EU)**

This catalog covers:  
**'08 KSF450B8F Engine**

GRID NO. This grid covers:  
**B-3 Cylinder Head**

E1111

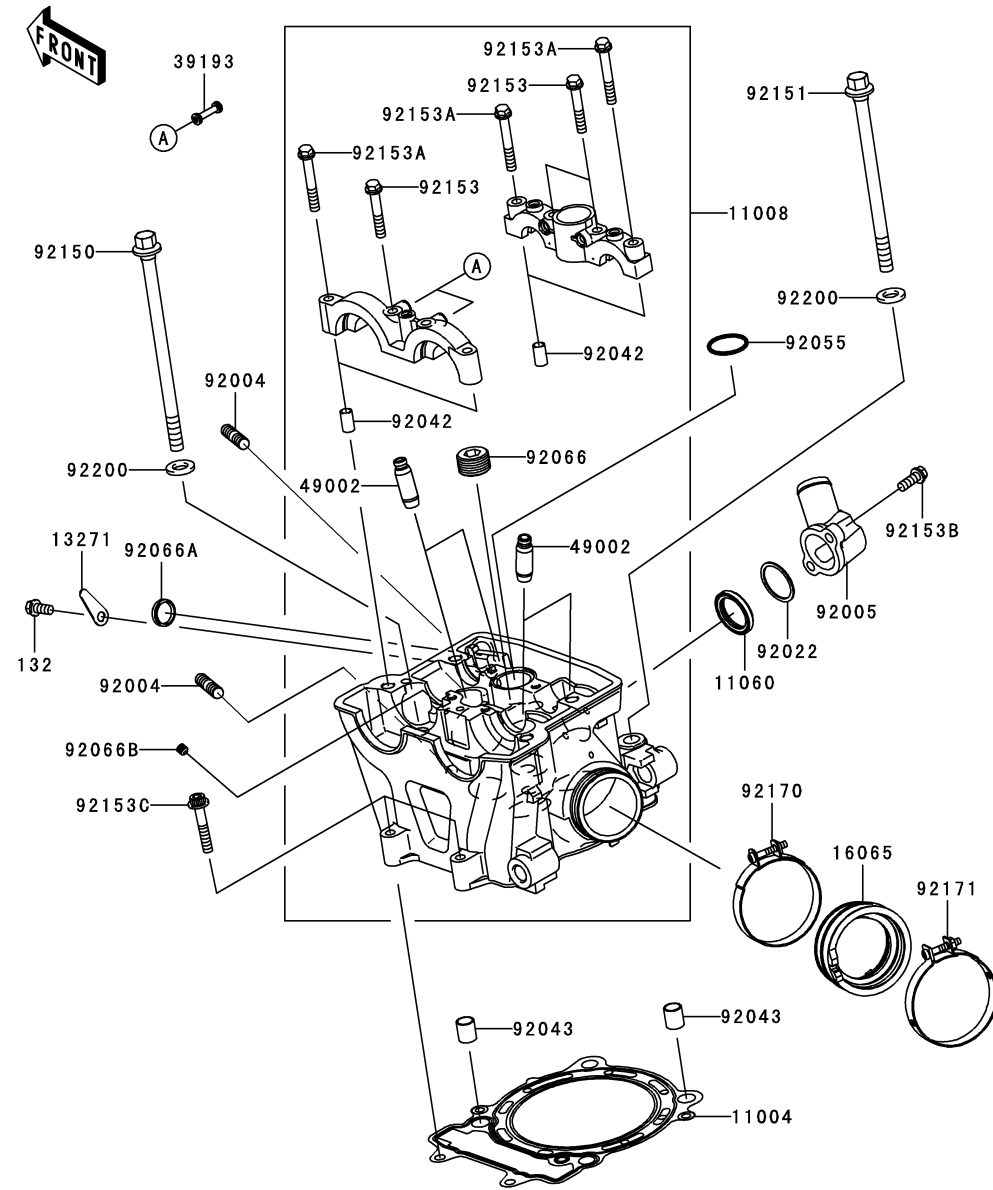

Ref. No.	Part No.	Description	Spec Code	Quantity-KSF450	
				'08	B8F
11004	11004-0073	GASKET-HEAD		1	
11008	11008-0098	HEAD-COMP-CYLINDER		1	
11060	11060-1300	GASKET,THERMOSTAT		1	
13271	13271-0675	PLATE		1	
16065	16065-0031	HOLDER-CARBURETOR		1	
39193	39193-0027	PIPE-OIL		2	
49002	49002-0007	GUIDE-VALVE	AR		
92004	92004-0025	STUD,8X22		2	
92005	92005-0018	FITTING		1	
92022	92022-161	WASHER,25.3X30X1		1	
92042	92042-007	PIN,DOWEL,6.3X8X14		4	
92043	92043-4009	PIN,10.1X12X14		2	
92055	92055-0046	RING-O,23.5X2.0		1	
92066	92066-0002	PLUG,PT1/2X12.5		1	
92066A	92066-0024	PLUG,4X18		1	
92066B	92066-0068	PLUG,6X6		1	
92150	92150-1934	BOLT,L=148		2	
92151	92151-1516	BOLT,10X133		2	
92153	92153-0338	BOLT,6X38		4	
92153A	92153-0339	BOLT,6X45		4	
92153B	92153-0695	BOLT,6X16		2	
92153C	92153-0810	BOLT,6X35		2	
92170	92170-1448	CLAMP		1	
92171	92171-0857	CLAMP,62MM		1	
92200	92200-0351	WASHER,10.5X19X2.3		4	
132	132L0612	BOLT-FLANGED-SMALL,6X12		1	

This catalog covers:  
**'08 KSF450B8F Engine**

GRID NO. **B-4** This grid covers:  
**Cylinder Head Cover**

E1112

Ref. No.	Part No.	Description	Spec Code	Quantity-KSF450			
				'08			
11061	11061-0079	GASKET,PLUG HOLE		1			
11061A	11061-0185	GASKET,CYLINDER HEAD COVER		1			
14091	14091-0796	COVER,CYLINDER HEAD		1			
92002	92002-1327	BOLT,FLANGED,6X22.5		3			
92055	92055-1352	RING-O,HEAD COVER BOLT		3			

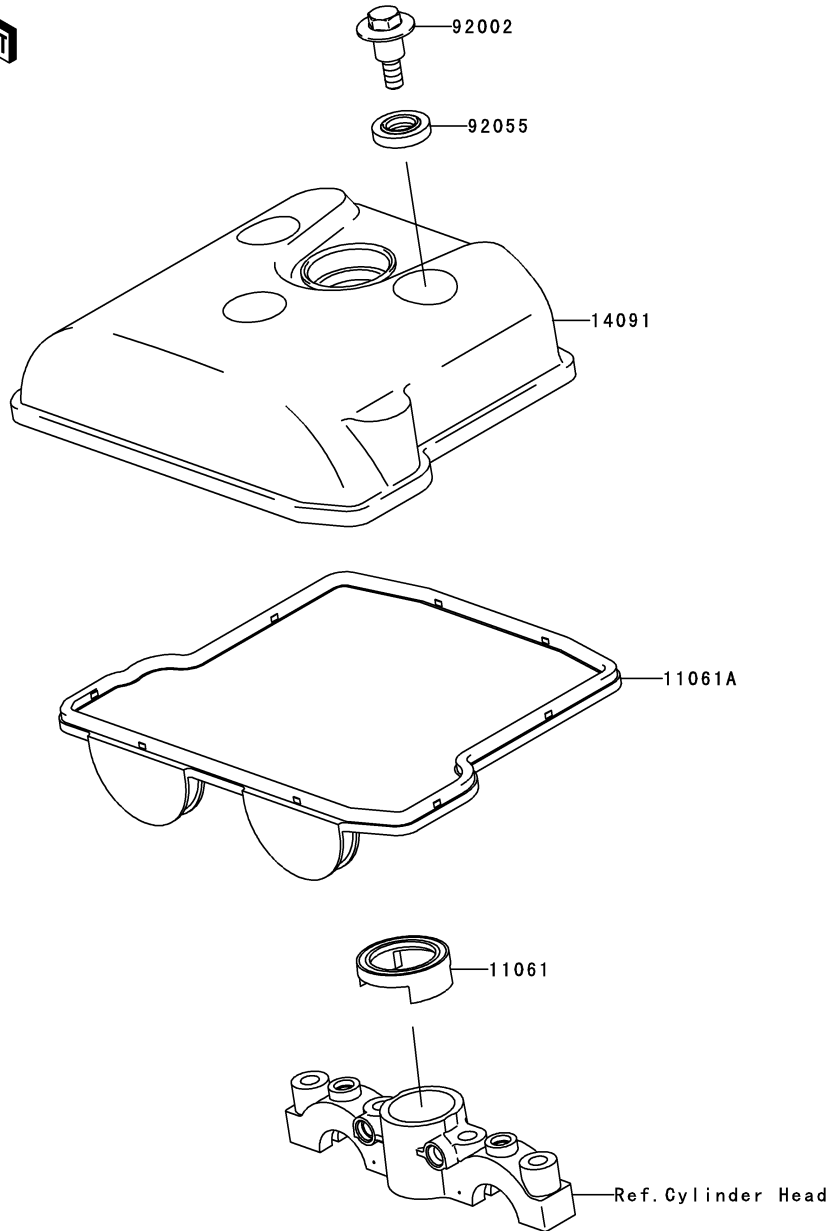

This catalog covers:

'08 KSF450B8F Engine

GRID NO.

**B-5**

This grid covers:

**Cylinder/Piston(s)**

E1120

Ref. No.	Part No.	Description	Spec Code	Quantity-KSF450			
				'08			
11005	11005-0080	CYLINDER-ENGINE					1
11061	11061-0234	GASKET,CYLINDER BASE					1
13001	13001-0079	PISTON-ENGINE					1
13002	13002-0014	PIN-PISTON					1
13008	13008-0022	RING-SET-PISTON					1
92033	92033-1188	RING-SNAP					2
92043	92043-4009	PIN,10.1X12X14					2
92153	92153-0844	BOLT,6X30					1

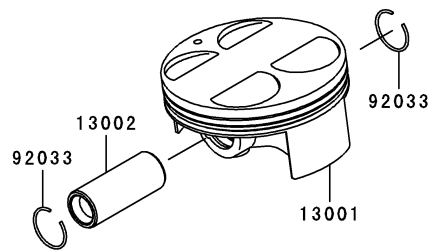
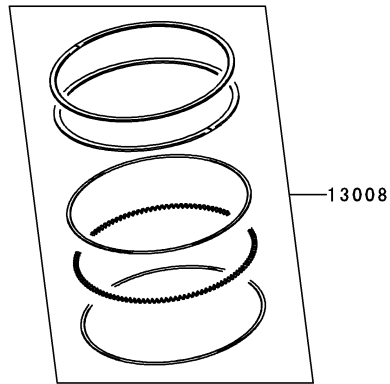
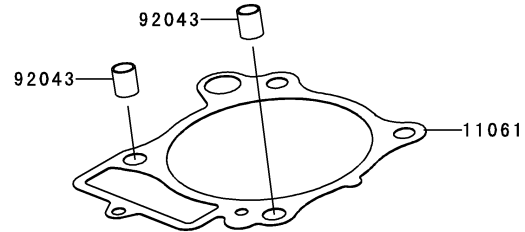
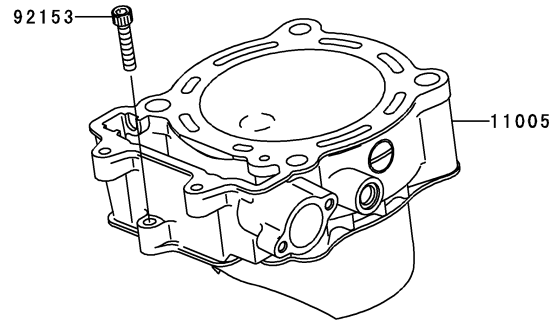

This catalog covers:  
**'08 KSF450B8F Engine**

GRID NO. **B-6** This grid covers:  
**Air Cleaner**

E1130

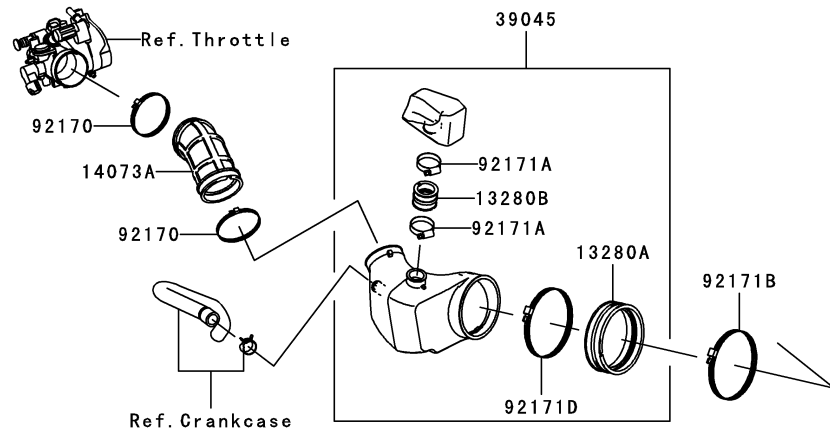
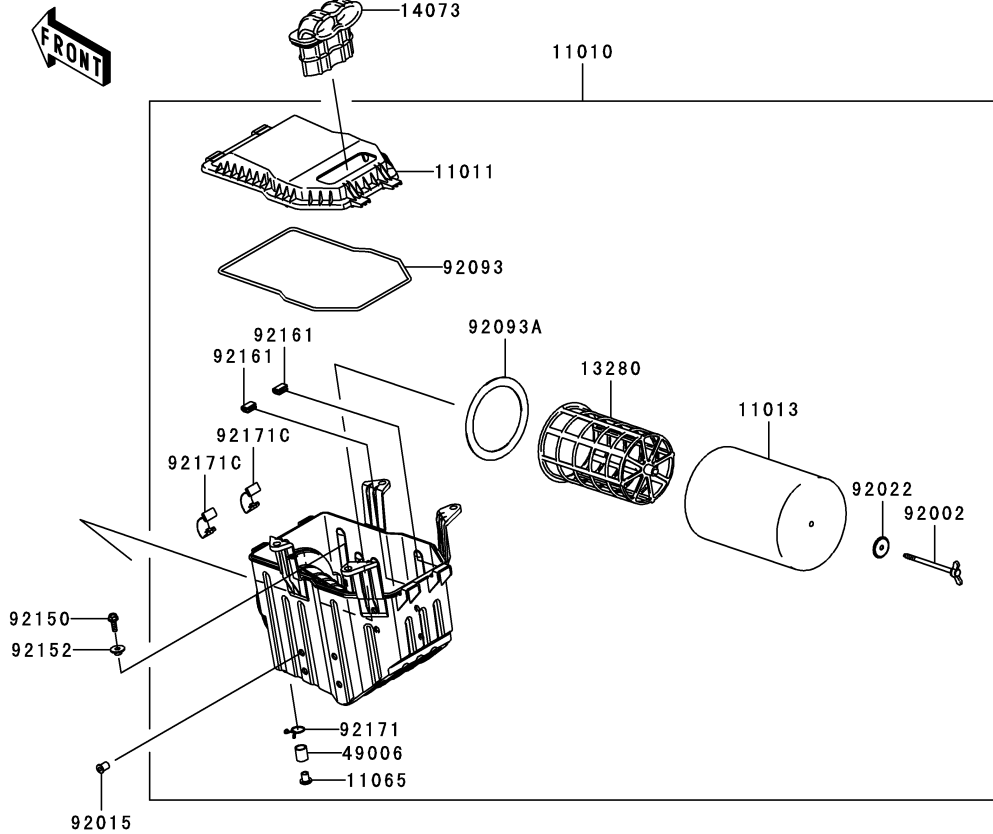

Ref. No.	Part No.	Description	Spec Code	Quantity-KSF450	
				'08	B8F
11010	11010-0135	FILTER-ASSY-AIR		1	
11011	11011-0075	CASE-AIR FILTER,UPP		1	
11013	11013-0017	ELEMENT-AIR FILTER		1	
11065	11065-0186	CAP		1	
13280	13280-0208	HOLDER,PLASTIC CAGE		1	
13280A	13280-0230	HOLDER,A/C-DUCT		1	
13280B	13280-0231	HOLDER,RESONATOR TANK		1	
14073	14073-0115	DUCT,A/C,INLET		1	
14073A	14073-0154	DUCT,THROBO-A/C		1	
39045	39045-0026	DUCT-ASSY		1	
49006	49006-0049	BOOT,DRAIN PIPE		1	
92002	92002-2274	BOLT,6X100		1	
92015	92015-1757	NUT,WELL,5MM		8	
92022	92022-2220	WASHER		1	
92093	92093-0104	SEAL		1	
92093A	92093-0116	SEAL		1	
92150	92150-1014	BOLT,6X20		4	
92152	92152-1255	COLLAR		4	
92161	92161-0538	DAMPER		2	
92170	92170-1764	CLAMP		2	
92171	92171-0837	CLAMP		1	
92171A	92171-0998	CLAMP,39MM		2	
92171B	92171-1383	CLAMP		1	
92171C	92171-1426	CLAMP,AIR FILTER CASE		2	
92171D	92171-1596	CLAMP,99.5MM		1	



E1210

Ref. No.	Part No.	Description	Spec Code	Quantity-KSF450			
				'08			
				B8F			

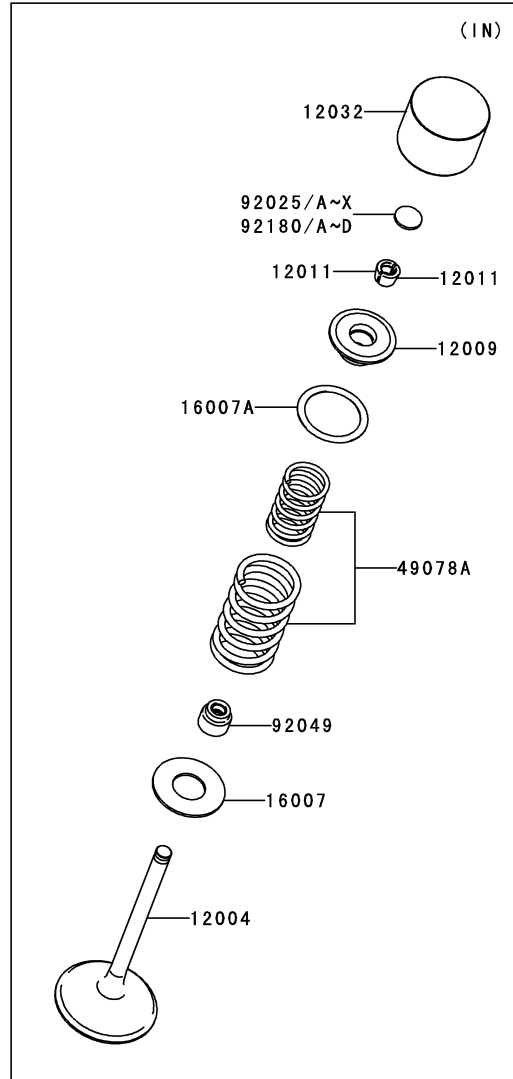
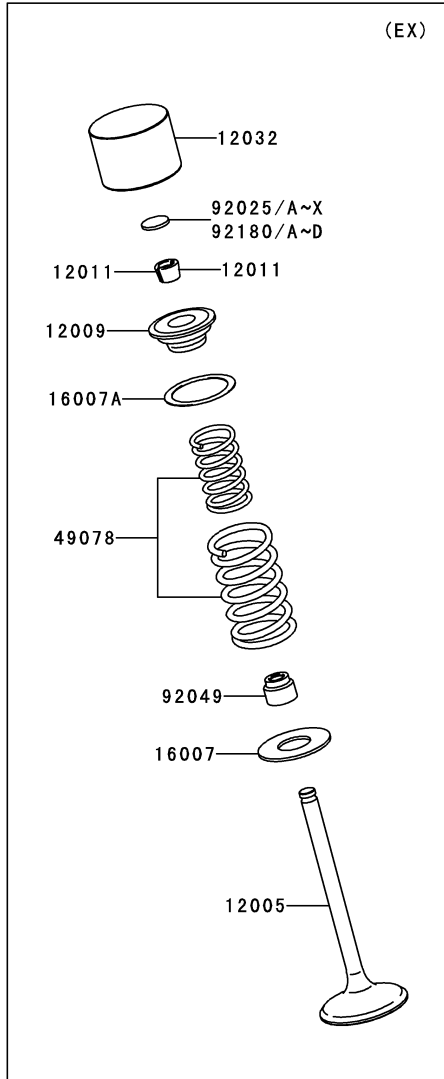

12004	12004-0026	VALVE-INTAKE		2
12005	12005-0036	VALVE-EXHAUST		2
12009	12009-0008	RETAINER-VALVE SPRING		4
12011	12011-1003	COLLET		8
12032	12032-0004	TAPPET		4
16007	16007-0022	SEAT-SPRING,11.6X25.5X1.0		4
16007A	16007-0026	SEAT-SPRING,19.8X25X0.3		4
49078	49078-0018	SPRING-ENGINE VALVE,EXHAUST		2
49078A	49078-0043	SPRING-ENGINE VALVE,INTAKE		2
92025	92025-1870	SHIM,T=2.00		4
92025A	92025-1871	SHIM,T=2.05	AR	
92025B	92025-1872	SHIM,T=2.10	AR	
92025C	92025-1873	SHIM,T=2.15	AR	
92025D	92025-1874	SHIM,T=2.20	AR	
92025E	92025-1875	SHIM,T=2.25	AR	
92025F	92025-1876	SHIM,T=2.30	AR	
92025G	92025-1877	SHIM,T=2.35	AR	
92025H	92025-1878	SHIM,T=2.40	AR	
92025I	92025-1879	SHIM,T=2.45	AR	
92025J	92025-1880	SHIM,T=2.50	AR	
92025K	92025-1881	SHIM,T=2.55	AR	
92025L	92025-1882	SHIM,T=2.60	AR	
92025M	92025-1883	SHIM,T=2.65	AR	
92025N	92025-1884	SHIM,T=2.70	AR	
92025O	92025-1885	SHIM,T=2.75	AR	
92025P	92025-1886	SHIM,T=2.80	AR	
92025Q	92025-1887	SHIM,T=2.85	AR	
92025R	92025-1888	SHIM,T=2.90	AR	
92025S	92025-1889	SHIM,T=2.95	AR	
92025T	92025-1890	SHIM,T=3.00	AR	
92025U	92025-1982	SHIM,T=2.425	AR	
92025V	92025-1983	SHIM,T=2.475	AR	
92025W	92025-1984	SHIM,T=2.525	AR	
92025X	92025-1985	SHIM,T=2.575	AR	
92049	92049-1062	SEAL-OIL,RVC2-5.5X8.5X8.3		4
92180	92180-1058	SHIM,T=2.375	AR	
92180A	92180-1059	SHIM,T=2.625	AR	
92180B	92180-1194	SHIM,T=2.675	AR	
92180C	92180-1195	SHIM,T=2.725	AR	
92180D	92180-1196	SHIM,T=2.775	AR	



E1321

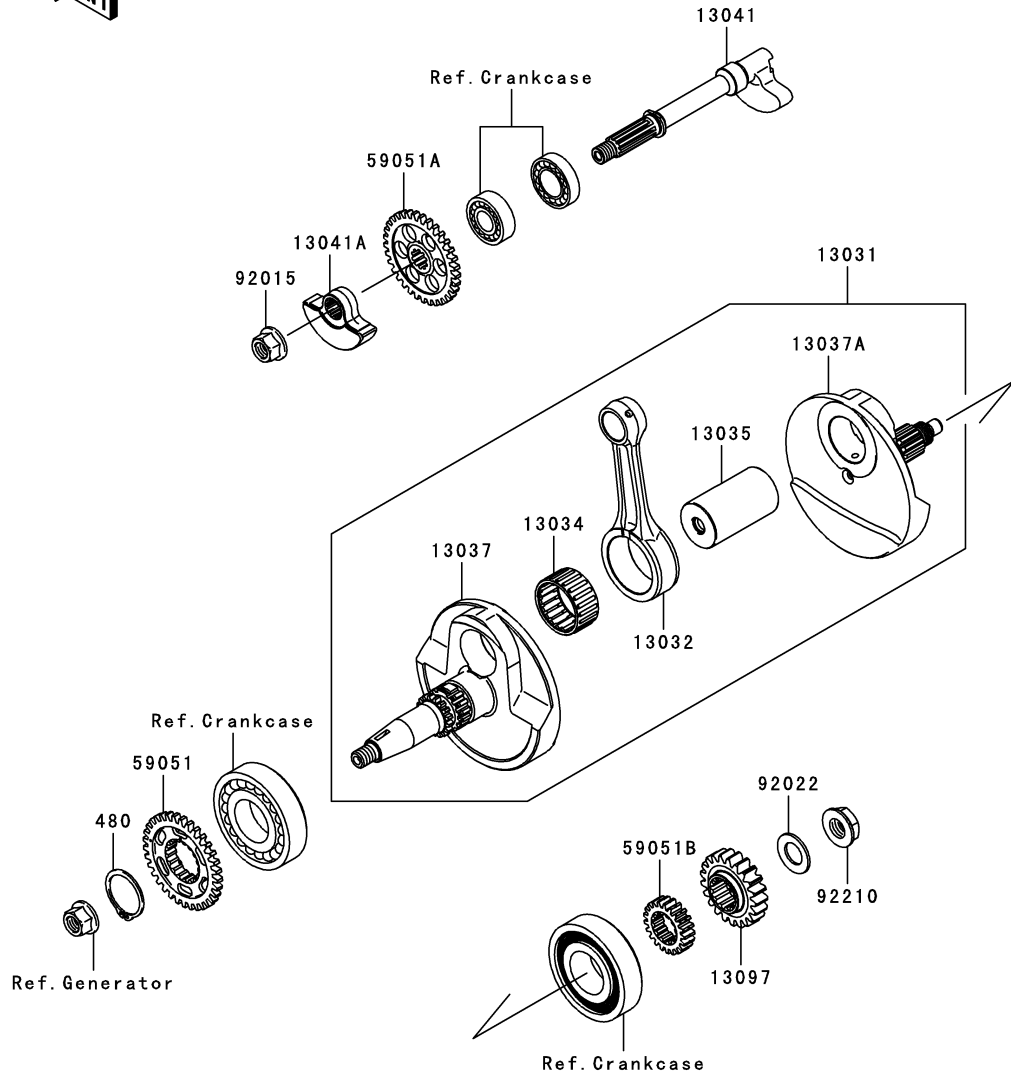

Ref. No.	Part No.	Description	Spec Code	Quantity-KSF450			
				'08			
				B8F			
13031	13031-0068	CRANKSHAFT-COMP					1
13032	13032-0054	ROD-CONNECTING					1
13034	13034-0006	BEARING-BIG END,B4					1
13035	13035-0013	PIN-CRANK					1
13037	13037-0082	CRANKSHAFT,LH					1
13037A	13037-0083	CRANKSHAFT,RH					1
13041	13041-0017	BALANCER,SHAFT					1
13041A	13041-0021	BALANCER,WEIGHT					1
13097	13097-0061	GEAR-PRIMARY SPUR,21T					1
59051	59051-0070	GEAR-SPUR,BALANCER DRIVE,33T					1
59051A	59051-0071	GEAR-SPUR,BALANCER DRIVEN,33T					1
59051B	59051-0075	GEAR-SPUR,OIL PUMP DRIVE,21T					1
92015	92015-1156	NUT,FLANGED,12MM					1
92022	92022-1356	WASHER,16.3X29X1.75					1
92210	92210-0350	NUT,LEFT HANDED,16MM					1
480	480J3200	CIRCLIP-TYPE-C,32MM					1

This catalog covers:  
**'08 KSF450B8F Engine**

GRID NO. **B-11** This grid covers:  
**Clutch**

E1350

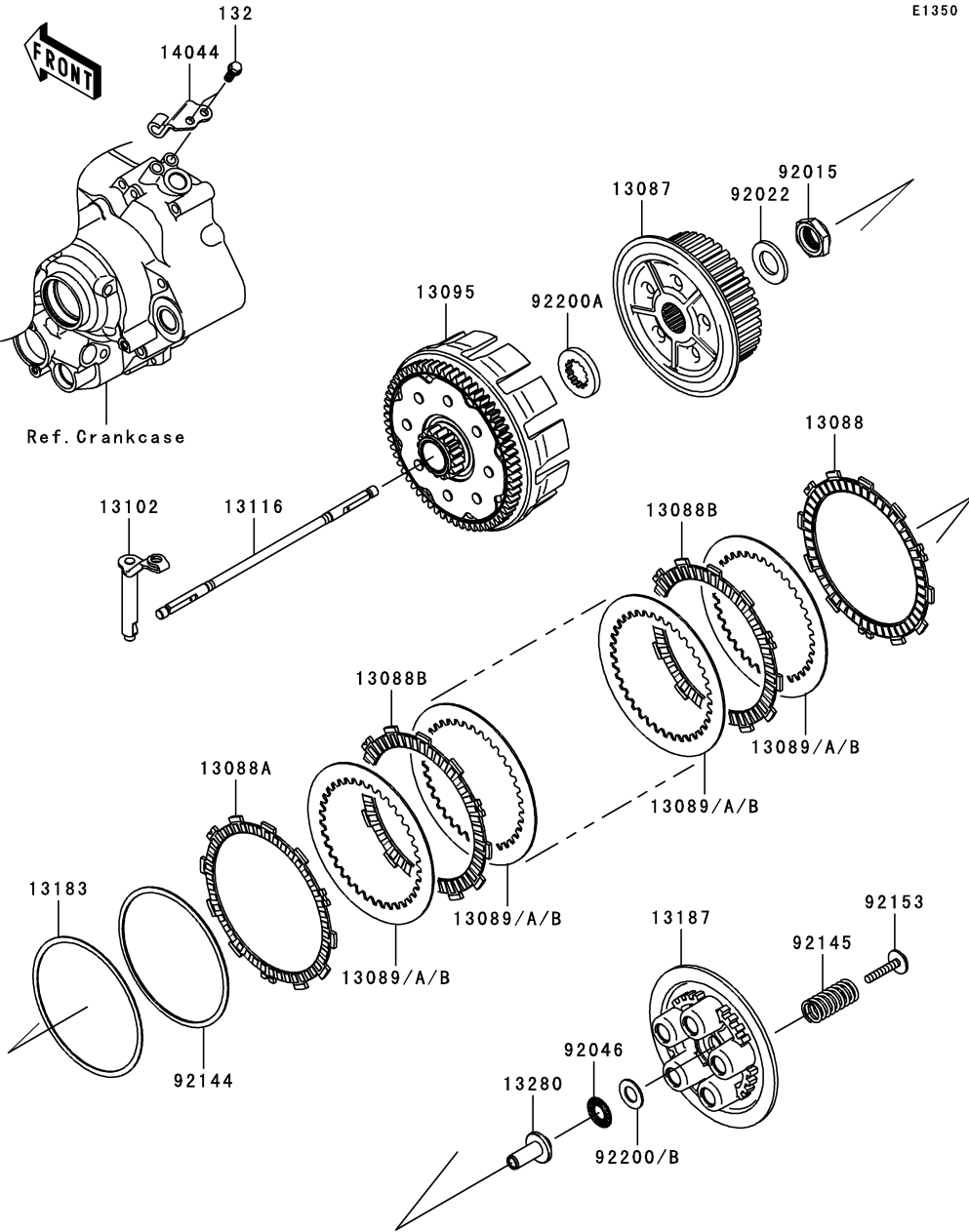

Ref. No.	Part No.	Description	Spec Code	Quantity-KSF450		
				'08	B8F	
13087	13087-0015	HUB-CLUTCH		1		
13088	13088-0010	PLATE-FRICTION		1		
13088A	13088-0029	PLATE-FRICTION		1		
13088B	13088-0035	PLATE-FRICTION		6		
13089	13089-1005	PLATE-CLUTCH,T=2.0		AR		
13089A	13089-1010	PLATE-CLUTCH,T=1.2		AR		
13089B	13089-1095	PLATE-CLUTCH,T=1.6		7		
13095	13095-0074	HOUSING-COMP-CLUTCH		1		
13102	13102-0030	RELEASE-COMP-CLUTCH		1		
13116	13116-0019	ROD-PUSH		1		
13183	13183-1722	PLATE,JUDDER SPRING		1		
13187	13187-0007	PLATE-CLUTCH OPERATING		1		
13280	13280-0067	HOLDER		1		
14044	14044-0027	HOLDER-CABLE		1		
92015	92015-1725	NUT,20MM		1		
92022	92022-1868	WASHER,20.3X36X3.7		1		
92046	92046-1190	BEARING-NEEDLE,FNTA-1326		1		
92144	92144-1591	SPRING,JUDDER		1		
92145	92145-0458	SPRING,45MM		5		
92153	92153-1847	BOLT,WP,6X35		5		
92200	92200-0045	WASHER,13.4X25X1.0		AR		
92200A	92200-0245	WASHER,25X41X5.5		1		
92200B	92200-1548	WASHER,13.4X25.0X1.5		1		
132	132Y0614	BOLT-FLANGED-SMALL,6X14		2		

This catalog covers:  
**'08 KSF450B8F Engine**

GRID NO. This grid covers:  
**B-12 Transmission**

E1361

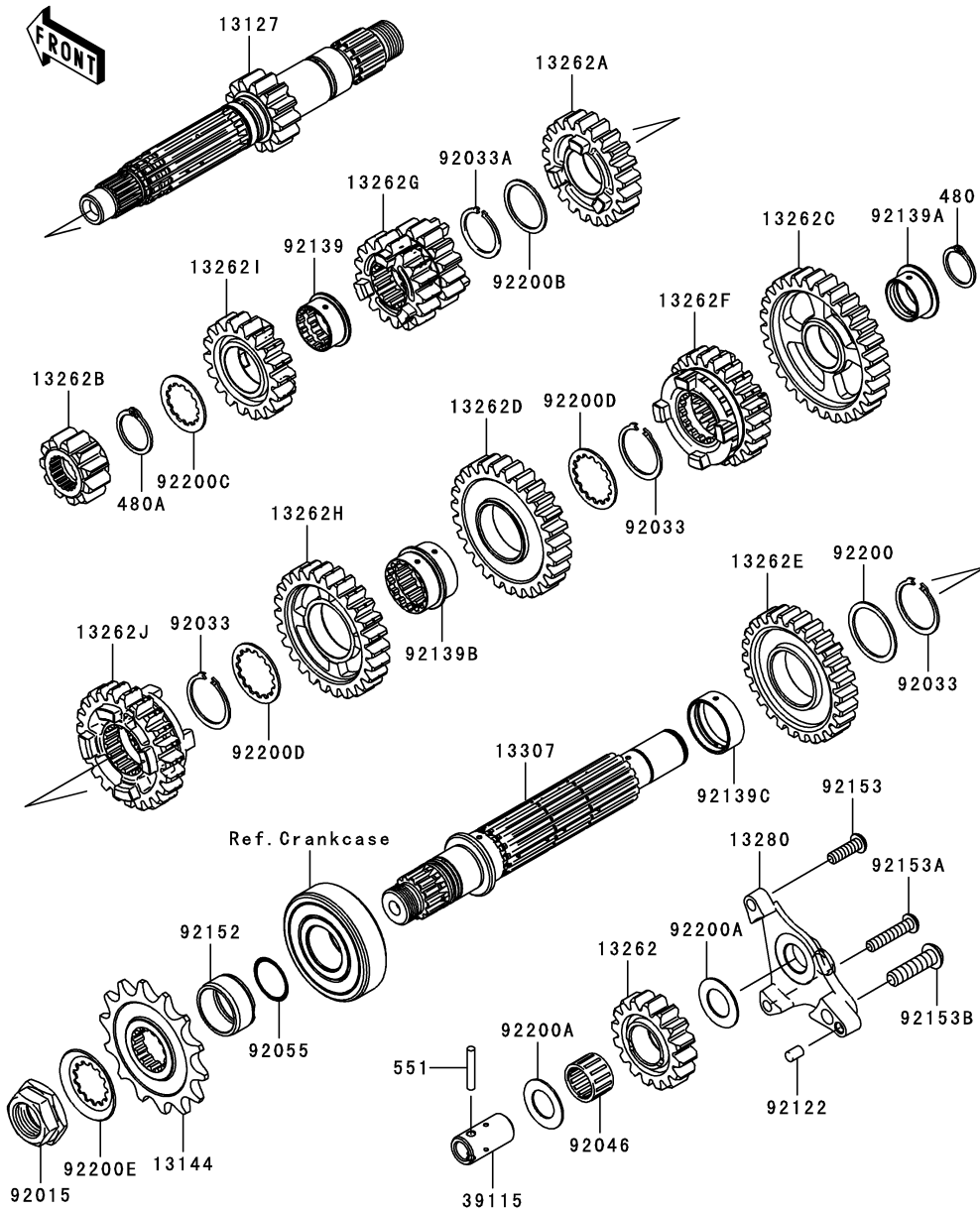

Ref. No.	Part No.	Description	Spec Code	Quantity-KSF450	
				'08	B8F
13127	13127-0039	SHAFT-TRANSMISSION INPUT		1	
13144	13144-0042	SPROCKET-OUTPUT,14T		1	
13262	13262-0352	GEAR-TRANSMISSION SPUR,16T		1	
13262A	13262-0355	GEAR,INPUT 5TH,21T		1	
13262B	13262-0356	GEAR,INPUT REV,11T		1	
13262C	13262-0357	GEAR,OUTPUT LOW,29T		1	
13262D	13262-0358	GEAR,OUTPUT 2ND,27T		1	
13262E	13262-0362	GEAR,OUTPUT REV,26T		1	
13262F	13262-0476	GEAR,OUTPUT 5TH,22T		1	
13262G	13262-0503	GEAR,INPUT 2ND&3RD,15T&17T		1	
13262H	13262-0504	GEAR,OUTPUT 3RD,26T		1	
13262I	13262-0505	GEAR,INPUT 4TH,18T		1	
13262J	13262-0572	GEAR-TRANSMISSION SPUR		1	
13280	13280-0188	HOLDER		1	
13307	13307-0002	SHAFT-COMP-OUTPUT		1	
39115	39115-0014	SHAFT-IDLER,REVERSE		1	
92015	92015-1963	NUT,20MM		1	
92033	92033-1037	RING-SNAP,25.9X30.6X1.2		3	
92033A	92033-1172	RING-SNAP,25MM		1	
92046	92046-0023	BEARING-NEEDLE,16X22X14		1	
92055	92055-0128	RING-O,21X1.9		1	
92122	92122-1201	ROLLER		1	
92139	92139-0152	BUSHING,21.4X26X12.8		1	
92139A	92139-0153	BUSHING,20X24X12.75		1	
92139B	92139-0154	BUSHING,25X31X22.7		1	
92139C	92139-0155	BUSHING,28X31X11		1	
92152	92152-0524	COLLAR,25X30X14		1	
92153	92153-1653	BOLT,TORX,6X20		1	
92153A	92153-1654	BOLT,TORX,6X30		1	
92153B	92153-1655	BOLT,TORX,8X30		1	
92200	92200-0051	WASHER,28.1X34.0X1.2		1	
92200A	92200-0302	WASHER,16X28X1		2	
92200B	92200-0303	WASHER,25.1X30X1.2		1	
92200C	92200-0304	WASHER,21.4X32X1.2		1	
92200D	92200-0305	WASHER,THRUST,28.3X34X1.2		2	
92200E	92200-1065	WASHER		1	
480	480J2000	CIRCLIP-TYPE-C,20MM		1	
480A	480J2200	CIRCLIP-TYPE-C,22MM		1	
551	551A0425	PIN-DOWEL,4X25		1	

This catalog covers:

'08 KSF450B8F Engine

GRID NO.

**B-13**

This grid covers:

**Gear Change Drum/Shift Fork(s)**

E1362

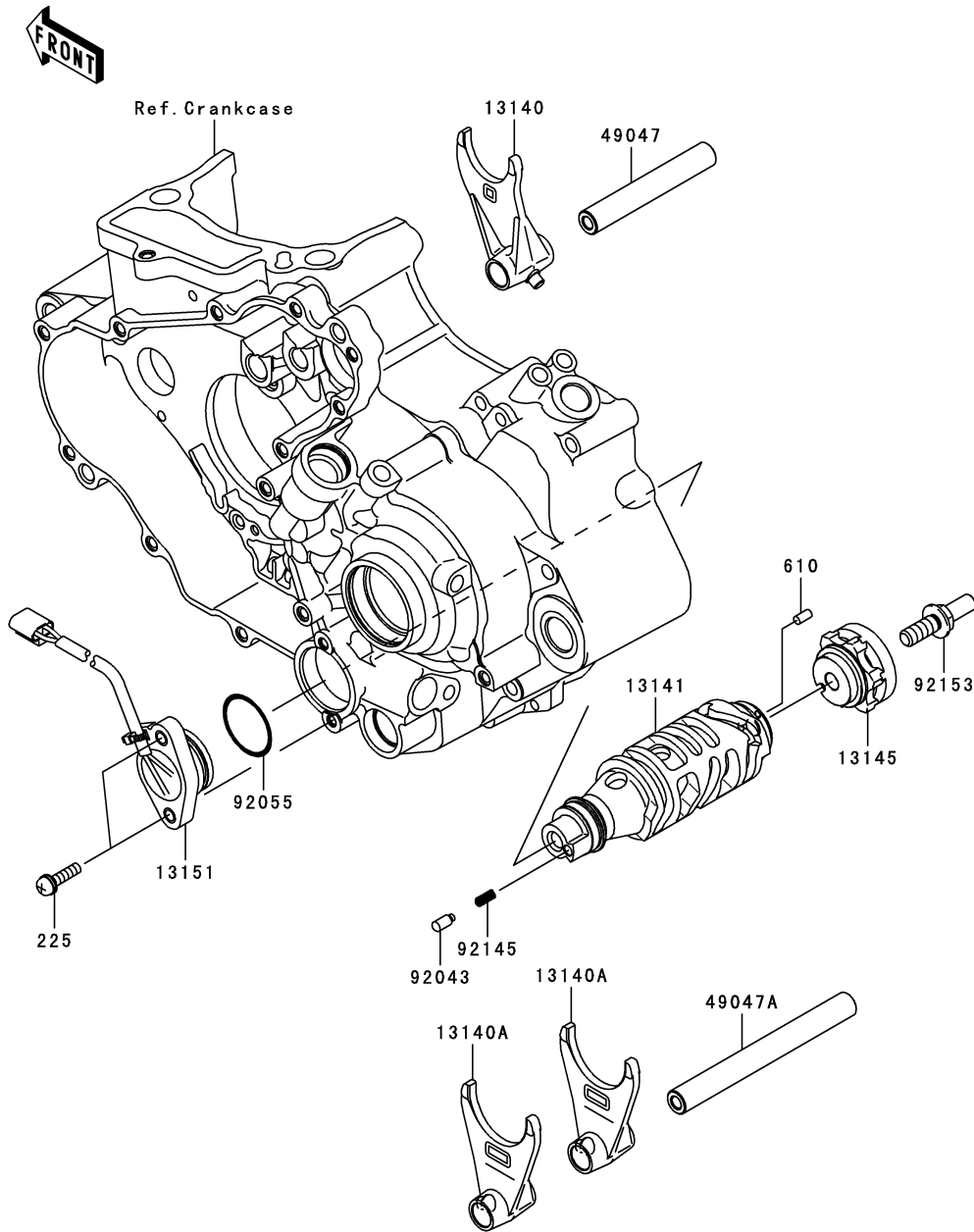

Ref. No.	Part No.	Description	Spec Code	Quantity-KSF450		
				'08		
13140	13140-0034	FORK-SHIFT,IN			1	
13140A	13140-0035	FORK-SHIFT,OUT			2	
13141	13141-0037	DRUM-CHANGE			1	
13145	13145-0022	CAM-CHANGE DRUM			1	
13151	13151-0029	SWITCH-COMP			1	
49047	49047-0024	ROD-SHIFT,IN			1	
49047A	49047-0025	ROD-SHIFT,OUT			1	
92043	92043-1654	PIN			1	
92055	92055-091	RING-O			1	
92145	92145-1414	SPRING			1	
92153	92153-0530	BOLT,8X20			1	
225	225B0520	SCREW-PAN-WSP-CROS,5X20			2	
610	610A0408	ROLLER,4X8			1	

This catalog covers:

'08 KSF450B8F Engine

GRID NO.

**B-14**

This grid covers:

**Gear Change Mechanism**

E1370

Ref. No.	Part No.	Description	Spec Code	Quantity-KSF450		
				'08		
13078	13078-0012	RATCHET				1
13116	13116-0024	ROD-PUSH				1
13161	13161-0055	LEVER-COMP-CHANGE SHAFT				1
13165	13165-0017	PAWL				2
13168	13168-0129	LEVER				1
13236	13236-0129	LEVER-COMP,POSITION				1
13272	13272-0073	PLATE				1
14075	14075-0005	CAP-ASSY				1
92022	92022-1827	WASHER,6X12.8X1.2				1
92026	92026-1217	SPACER				1
92043	92043-0140	PIN,8X45				1
92043A	92043-1676	PIN,PLUNGER				2
92049	92049-0094	SEAL-OIL,6.6X11X2.5				1
92145	92145-0397	SPRING,23.6MM				1
92145A	92145-0453	SPRING				2
92145B	92145-0457	SPRING				1
92145C	92145-1493	SPRING,RETURN				1
92151	92151-1930	BOLT,FLANGED-SMALL,6X25				1
92152	92152-1414	COLLAR				1
92152A	92152-1419	COLLAR,RETURN SPRING				1
92153	92153-0848	BOLT,6X15				1
92161	92161-0359	DAMPER				1
132	132Y0614	BOLT-FLANGED-SMALL,6X14				2
172	172G0612	BOLT-STUD,6X12				1
311	311G0600	NUT-HEX,6MM				1
670	670B2012	O RING,12MM				1

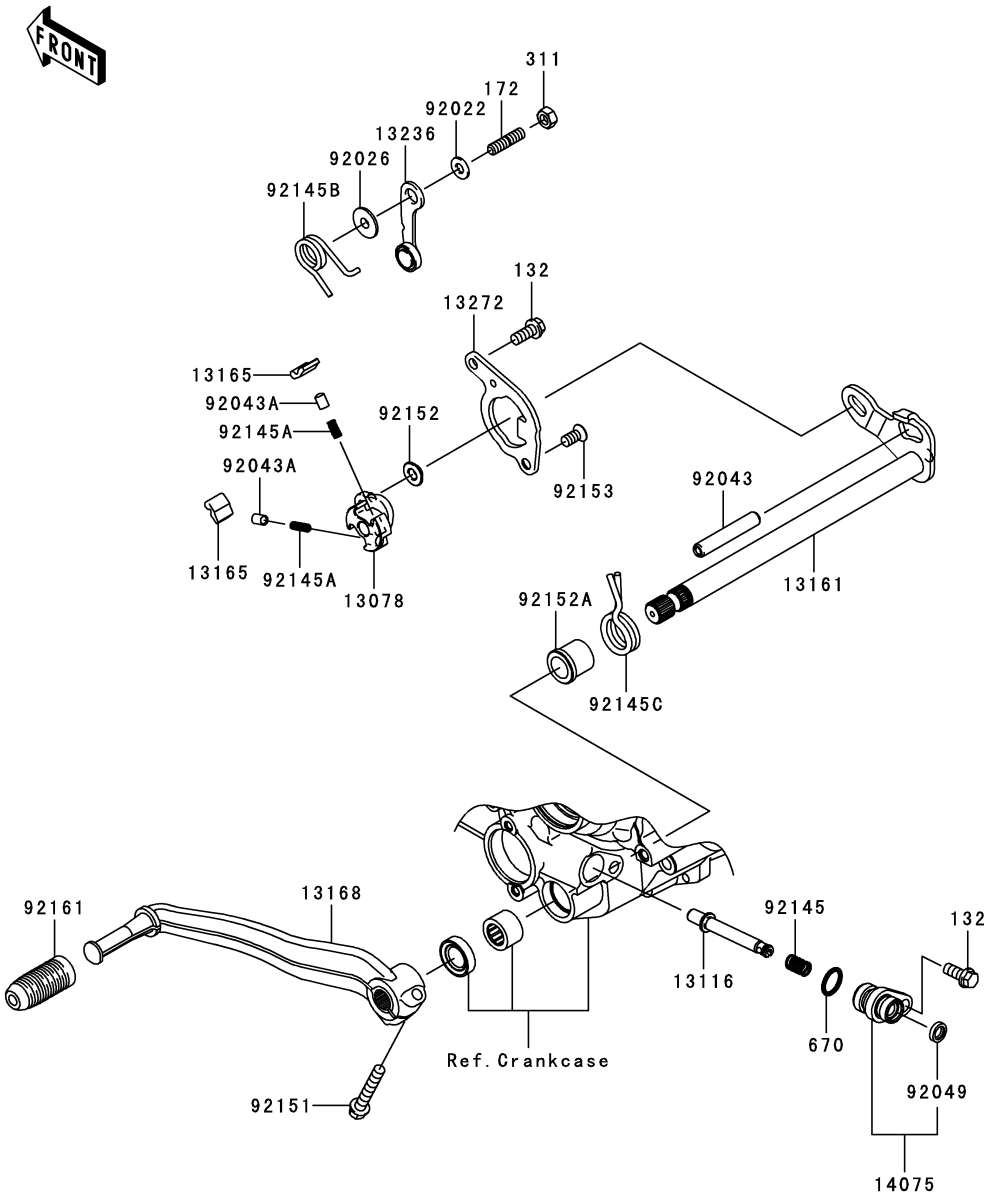

This catalog covers:  
**'08 KSF450B8F Engine**

GRID NO. **C-3** This grid covers:  
**Crankcase**

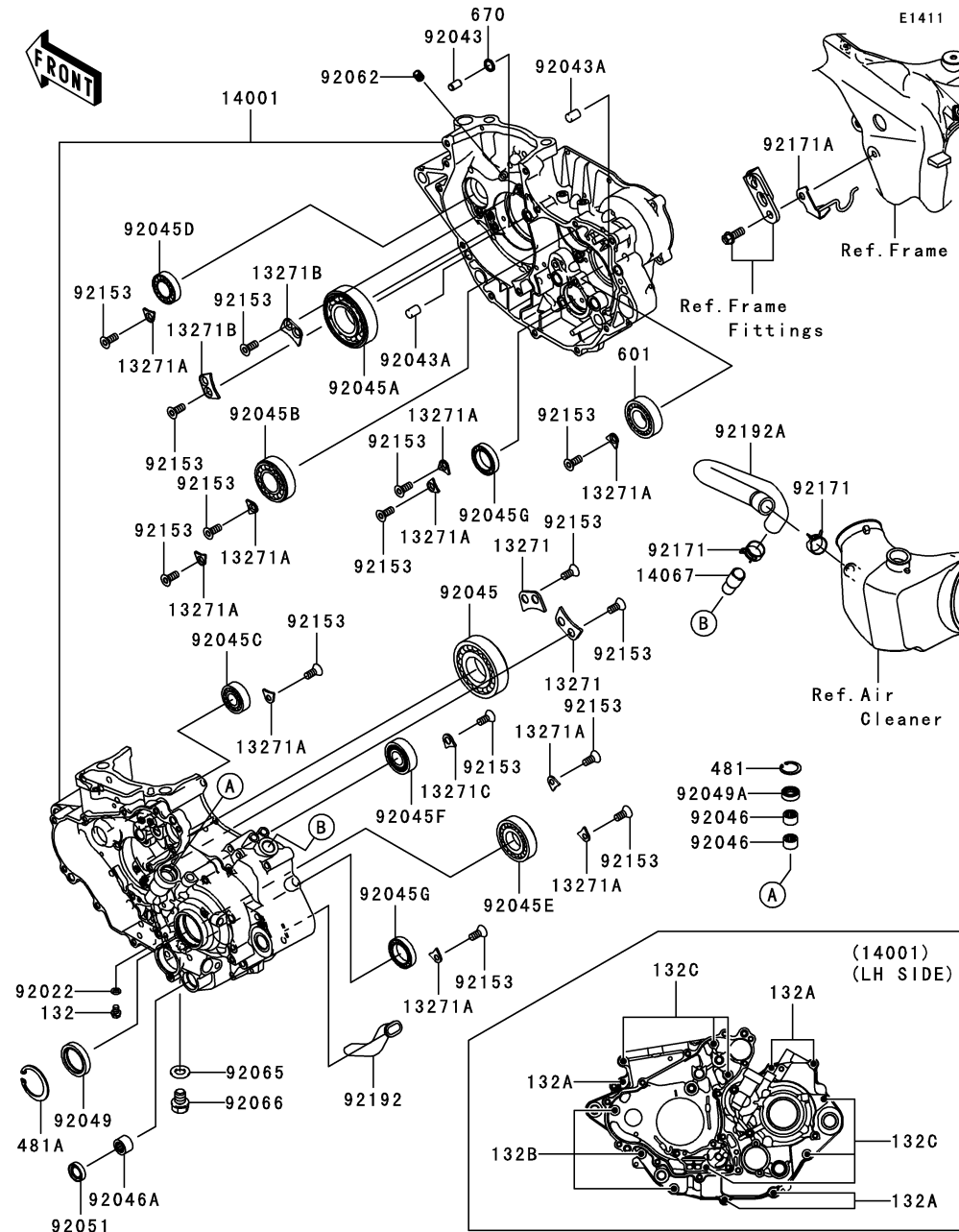

Ref. No.	Part No.	Description	Spec Code	Quantity-KSF450	
				'08	B8F
13271	13271-0334	PLATE		2	
13271A	13271-0582	PLATE		10	
13271B	13271-0867	PLATE		2	
13271C	13271-0943	PLATE		1	
14001	14001-0079	SET-CRANKCASE		1	
14067	14067-006	FITTING,BREATHER		1	
92022	92022-304	WASHER,6.2X11X1		1	
92043	92043-0130	PIN,8X14		1	
92043A	92043-1506	PIN,10X14		2	
92045	92045-0024	BEARING-BALL,B32-32U-A-EC4 UR5		1	
92045A	92045-0031	BEARING-BALL,B32-32-A-DUX8EC4		1	
92045B	92045-0035	BEARING-BALL,25X52X15		1	
92045C	92045-0037	BEARING-BALL,6202SH2C3		1	
92045D	92045-0038	BEARING-BALL,6904C3UR5		1	
92045E	92045-0056	BEARING-BALL,25X62X17		1	
92045F	92045-0057	BEARING-BALL,3TM-5X0391LUC3		1	
92045G	92045-1432	BEARING-BALL,6805JRZ		2	
92046	92046-1010	BEARING-NEEDLE,HK1210		2	
92046A	92046-1148	BEARING-NEEDLE,HK1312		1	
92049	92049-0030	SEAL-OIL,TC 30 40 7		1	
92049A	92049-1475	SEAL-OIL,CLUTCH RELEASE		1	
92051	92051-005	SEAL-OIL,TB13225.5		1	
92062	92062-1078	NOZZLE,6X8,GREEN		1	
92065	92065-097	GASKET,12X22X2		1	
92066	92066-1174	PLUG,OIL DRAIN,12X15		1	
92153	92153-0848	BOLT,6X15		19	
92171	92171-0862	CLAMP		2	
92171A	92171-0879	CLAMP		1	
92192	92192-0318	TUBE,OIL RETURN		1	
92192A	92192-0432	TUBE,BREATHER		1	
132	132L0608	BOLT-FLANGED-SMALL,6X8		1	
132A	132Y0650	BOLT-FLANGED-SMALL,6X50		5	
132B	132Y0660	BOLT-FLANGED-SMALL,6X60		3	
132C	132Y0680	BOLT-FLANGED-SMALL,6X80		6	
481	481J2100	CIRCLIP		1	
481A	481J4000	CIRCLIP-TYPE-C,40MM		1	
601	601A6204	BEARING-BALL,#6204		1	
670	670D1508	O RING,8MM		1	



This catalog covers:  
**'08 KSF450B8F Engine**

GRID NO. This grid covers:  
**C-5 Throttle**

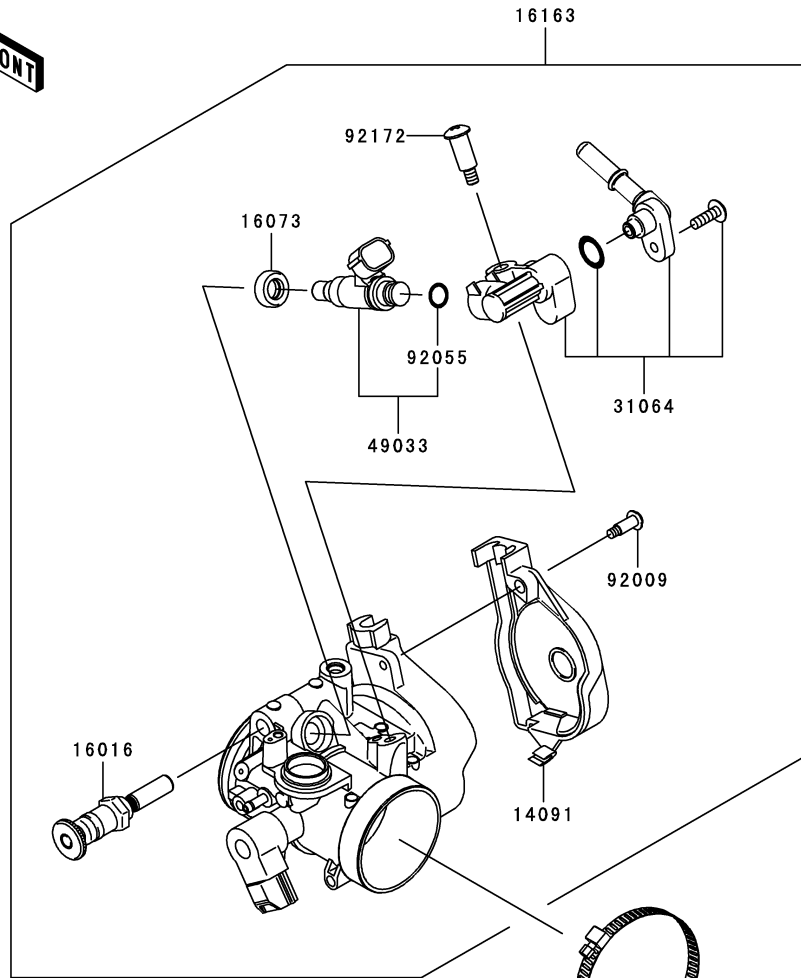

Ref. Air Cleaner

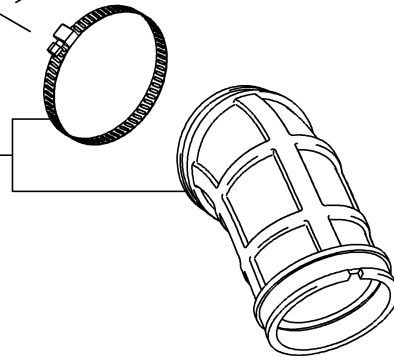

E1510

Ref. No.	Part No.	Description	Spec Code	Quantity-KSF450		
				'08		
14091	14091-0728	COVER				1
16016	16016-0022	PLUNGER				1
16073	16073-3707	INSULATOR				1
16163	16163-0083	THROTTLE-ASSY,SINGLE BARREL42				1
31064	31064-0090	PIPE-COMP				1
49033	49033-0010	NOZZLE-INJECTION				1
92009	92009-1549	SCREW,4X4.4				1
92055	92055-1622	RING-O,INJECTION NOZZLE				1
92172	92172-0064	SCREW,PIPE INJECTION				1

This catalog covers:  
**'08 KSF450B8F Engine**

GRID NO. This grid covers:  
**C-6 Fuel Pump**

E1520

Ref. No.	Part No.	Description	Spec Code	Quantity-KSF450			
				'08			
49040	49040-0020	PUMP-FUEL					1
51044	51044-0031	TUBE-ASSY,FUEL					1
92153	92153-1283	BOLT,FLANGED,6X12					5
670	670E5075	O RING					1

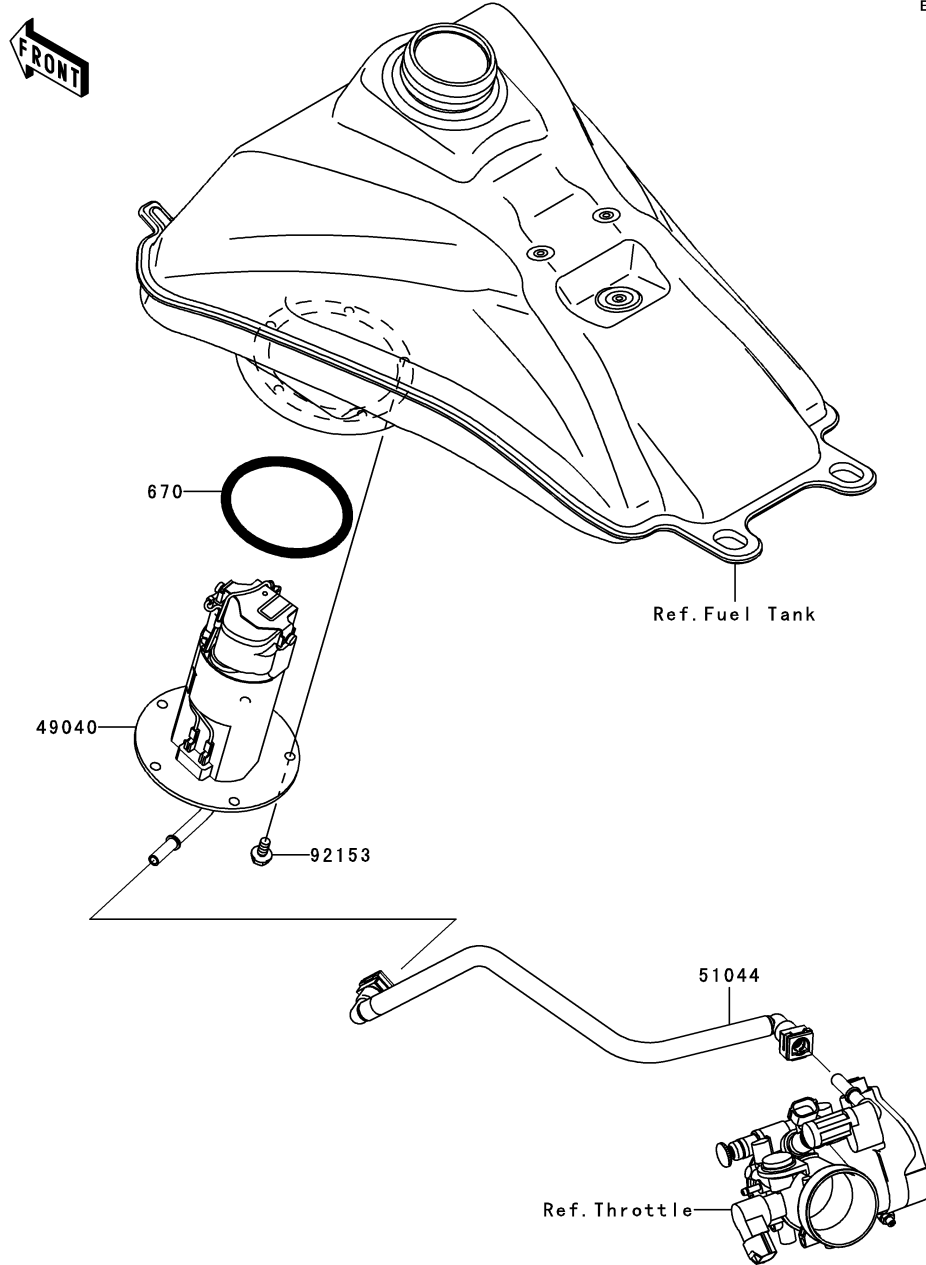

This catalog covers:

'08 KSF450B8F Engine

GRID NO.

C-7

This grid covers:

Fuel Injection

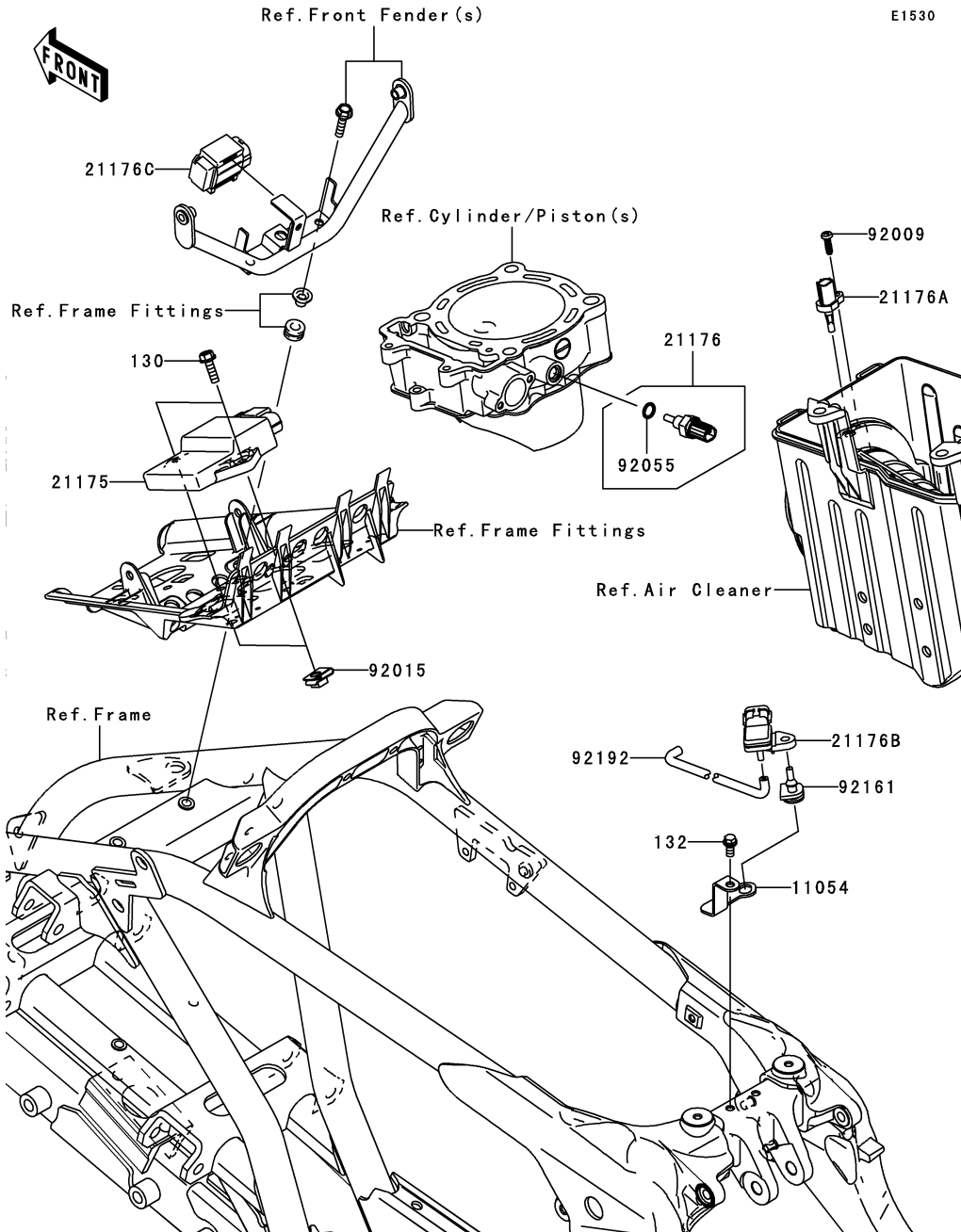

E1530

Ref. No.	Part No.	Description	Spec Code	Quantity-KSF450		
				'08	B8F	
11054	11054-1838	BRACKET,PRESSURE SENSOR			1	
21175	21175-0099	CONTROL UNIT-ELECTRONIC			1	
21176	21176-0009	SENSOR,WATER TEMP			1	
21176A	21176-0048	SENSOR,AIR TEMPERATURE			1	
21176B	21176-0058	SENSOR,PRESSURE			1	
21176C	21176-0066	SENSOR,VEHICLE-DOWN			1	
92009	92009-1984	SCREW,TAPPING,5X16			1	
92015	92015-1602	NUT,6MM			2	
92055	92055-0016	RING-O,9.5X1.9			1	
92161	92161-0041	DAMPER			1	
92192	92192-0356	TUBE,3X7X17&190			1	
130	130J0620	BOLT-FLANGED,6X20			2	
132	132Y0612	BOLT-FLANGED-SMALL,6X12			1	

This catalog covers:  
**'08 KSF450B8F Engine**

GRID NO. **C-8** This grid covers:  
**Oil Pump**

E1712

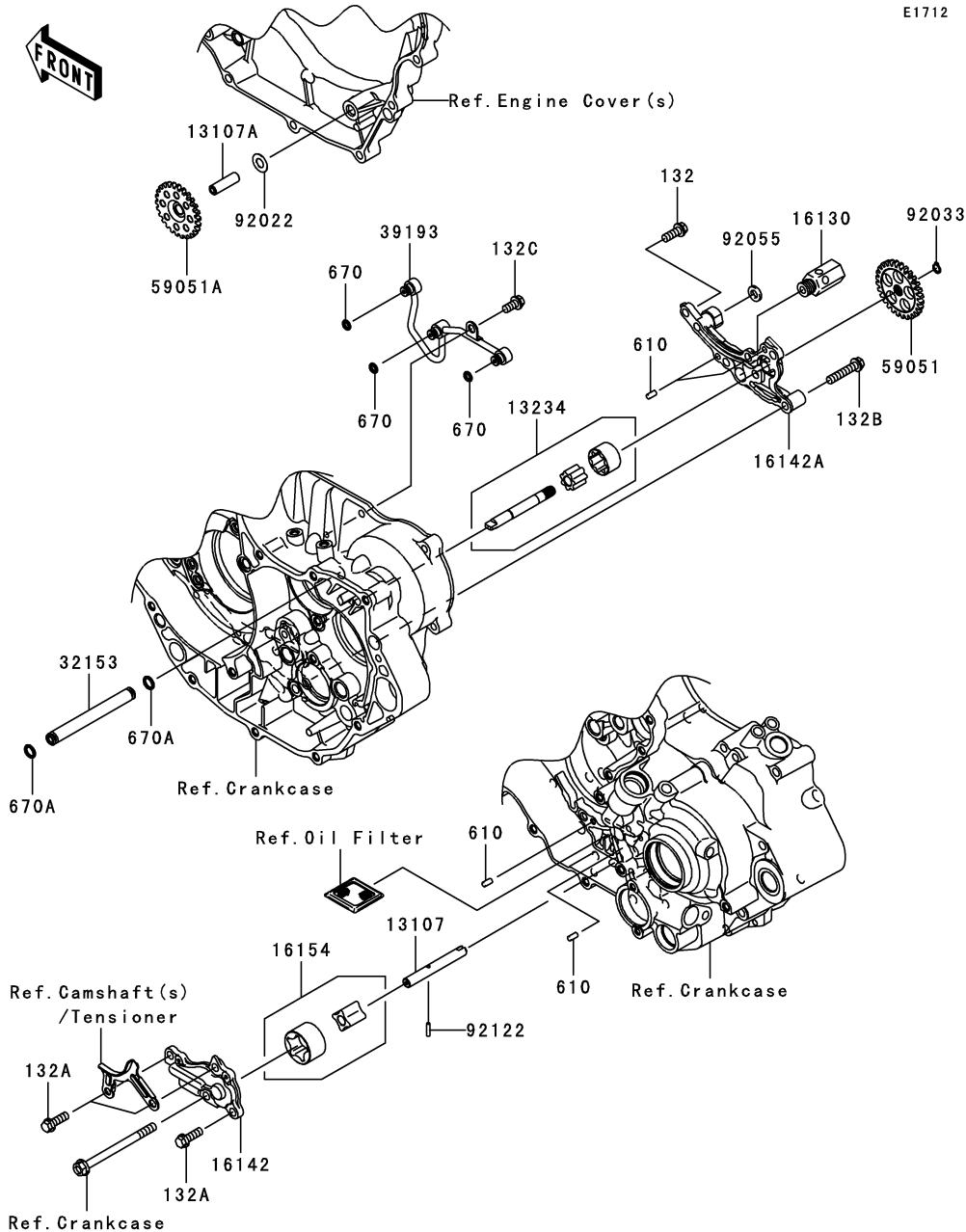

Ref. No.	Part No.	Description	Spec Code	Quantity-KSF450	
				'08	B8F
13107	13107-0134	SHAFT,OIL PUMP,SCAVENGE		1	
13107A	13107-0138	SHAFT,O/P IDLE		1	
13234	13234-0029	SHAFT-COMP,OIL PUMP,FEED		1	
16130	16130-1058	VALVE-ASSY-RELIEF		1	
16142	16142-0032	COVER-PUMP		1	
16142A	16142-0033	COVER-PUMP		1	
16154	16154-0069	ROTOR-PUMP,SCAVENGE		1	
32153	32153-1189	PIPE		1	
39193	39193-0038	PIPE-OIL		1	
59051	59051-0044	GEAR-SPUR,O/P DRIVEN,28T		1	
59051A	59051-0073	GEAR-SPUR,O/P IDLE,26T		1	
92022	92022-1475	WASHER,8X16X0.5		1	
92033	92033-0019	RING-SNAP		1	
92055	92055-074	RING-O,OD=13		1	
92122	92122-0021	ROLLER,2.5X11.8		1	
132	132G0616	BOLT-FLANGED-SMALL,6X16		5	
132A	132G0618	BOLT-FLANGED-SMALL,6X18		3	
132B	132G0630	BOLT-FLANGED-SMALL,6X30		1	
132C	132J0612	BOLT-FLANGED-SMALL,6X12		1	
610	610A0408	ROLLER,4X8		4	
670	670D1505	O RING		3	
670A	670D1507	O RING,7MM		2	

This catalog covers:  
**'08 KSF450B8F Engine**

GRID NO. **C-9** This grid covers:  
**Oil Filter**

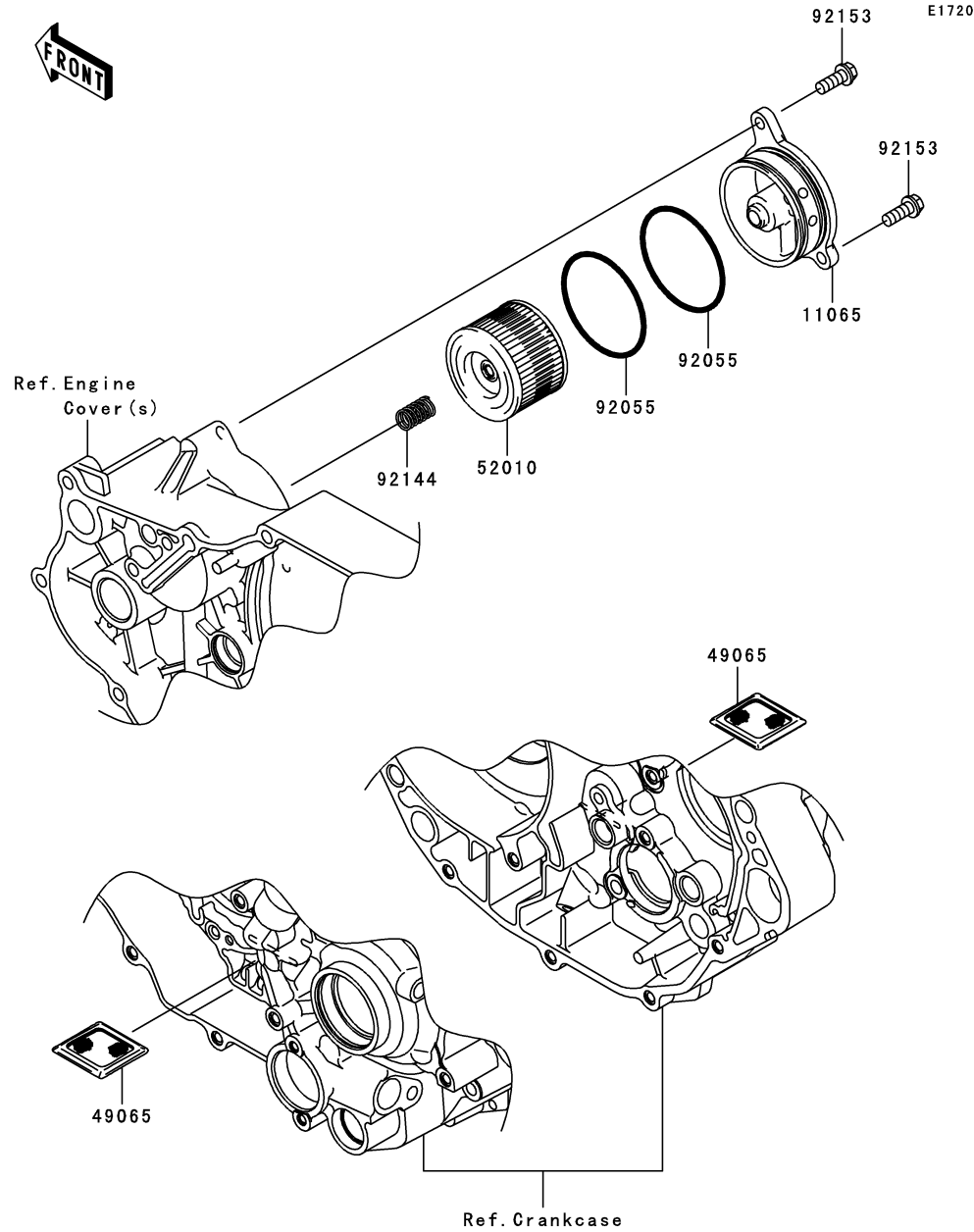

Ref. No.	Part No.	Description	Spec Code	Quantity-KSF450			
				'08			
11065	11065-0107	CAP,OIL FILTER					1
49065	49065-0019	FILTER-OIL,STRAINER					2
52010	52010-1053	ELEMENT-OIL FILTER					1
92055	92055-1577	RING-O,52.6X2.4					2
92144	92144-1761	SPRING					1
92153	92153-0695	BOLT,6X16					2

This catalog covers:  
**'08 KSF450B8F Engine**

GRID NO. This grid covers:  
**C-10 Generator**

E1810

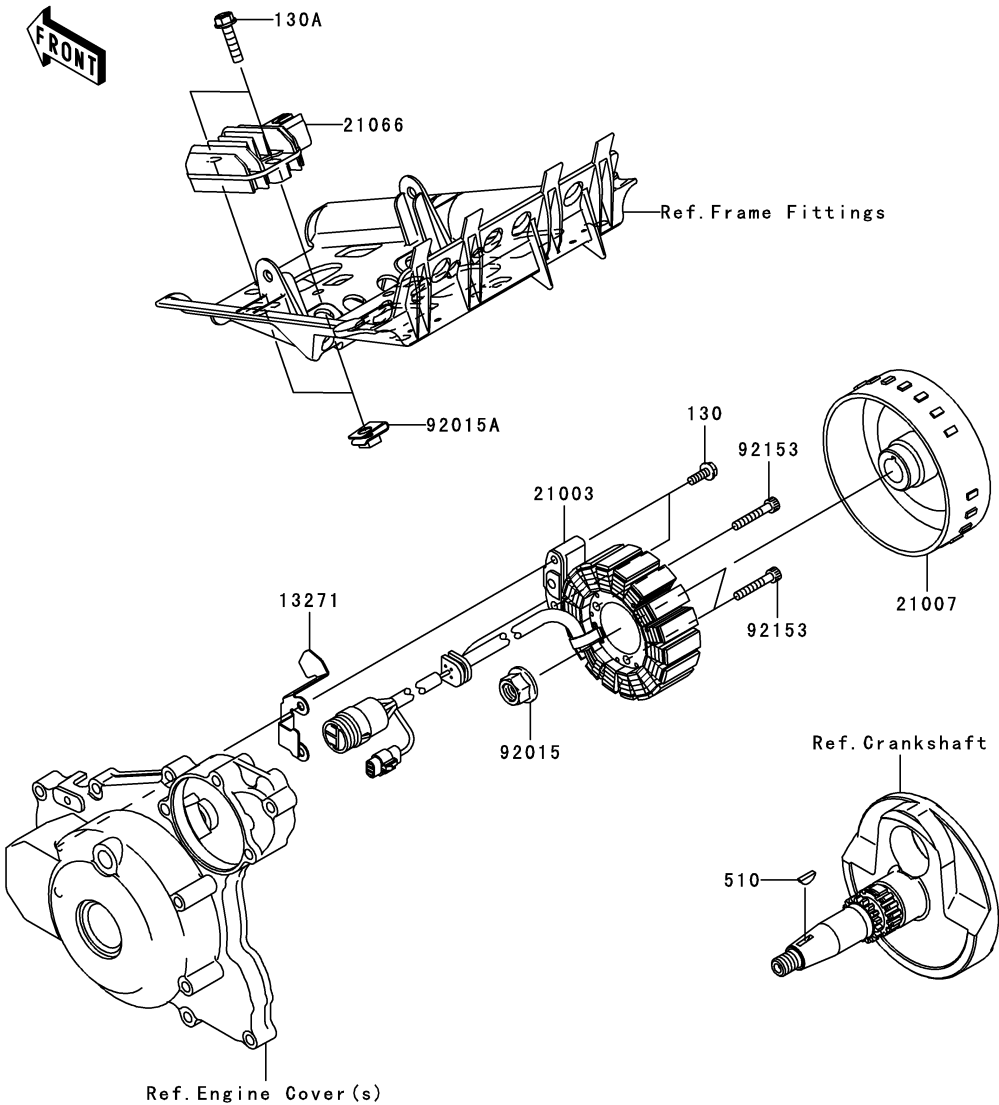

Ref. No.	Part No.	Description	Spec Code	Quantity-KSF450		
				'08		
13271	13271-0760	PLATE				1
21003	21003-0067	STATOR				1
21007	21007-0107	ROTOR				1
21066	21066-0017	REGULATOR-VOLTAGE				1
92015	92015-1156	NUT,FLANGED,12MM				1
92015A	92015-1602	NUT,6MM				2
92153	92153-1894	BOLT,SOCKET,5X30				3
130	130G0514	BOLT-FLANGED,5X14				2
130A	130J0625	BOLT-FLANGED,6X25				2
510	510A3200	KEY-WOODRUFF				1

This catalog covers:

'08 KSF450B8F Engine

GRID NO.

**C-11**

This grid covers:

**Ignition System**

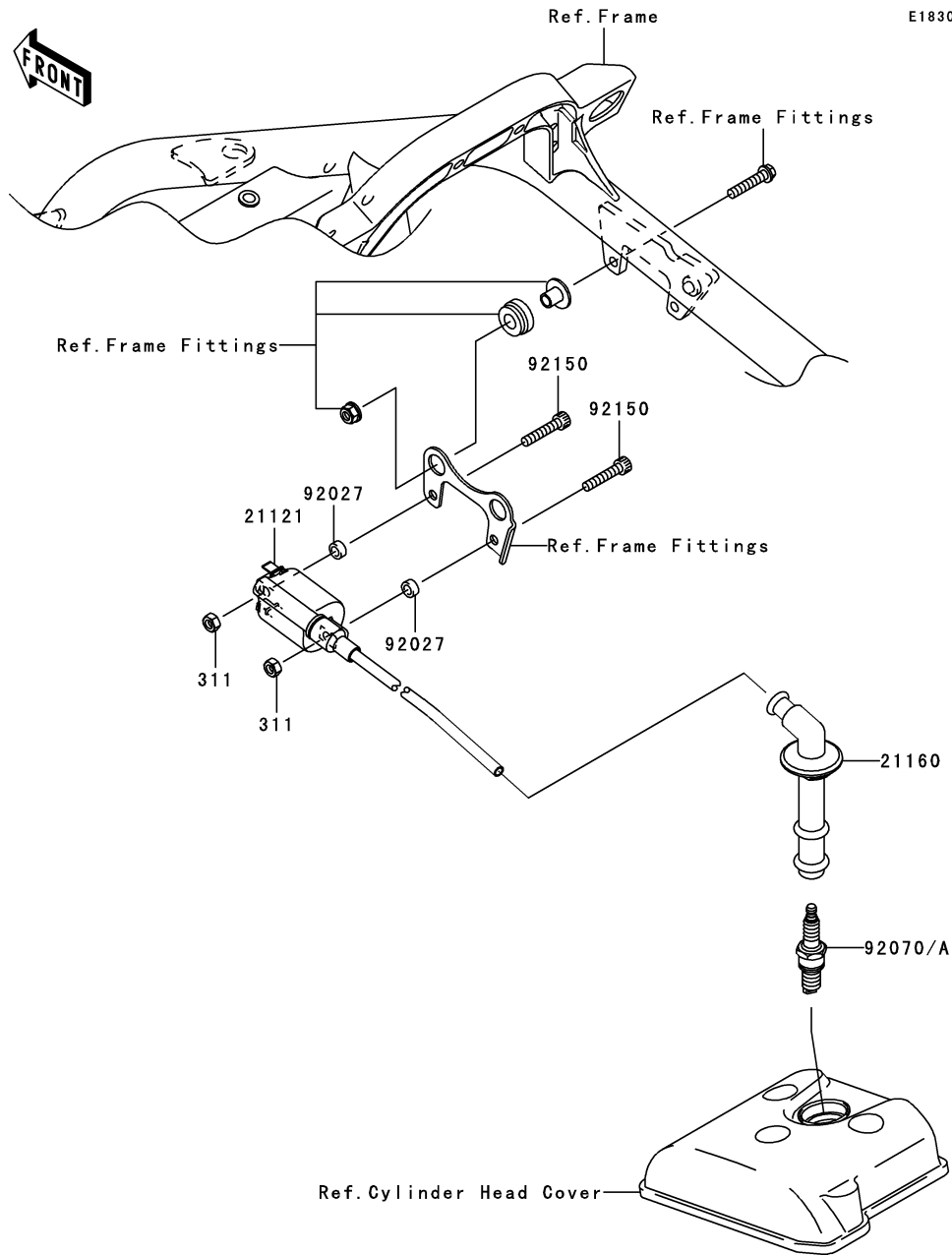

Ref. No.	Part No.	Description	Spec Code	Quantity-KSF450			
				'08			
21121	21121-0032	COIL-IGNITION					1
21160	21160-0011	CAP-ASSY-PLUG					1
92027	92027-1885	COLLAR,6.5X10.5X4.5					2
92070	92070-0020	PLUG-SPARK,CPR8EB-9(NGK)					1
92070A	92070-0021	PLUG-SPARK,CPR9EB-9(NGK)					AR
		(OPTION)					
92150	92150-1433	BOLT,SOCKET,6X30					2
311	311G0600	NUT-HEX,6MM					2

This catalog covers:  
**'08 KSF450B8F Engine**

GRID NO. **C-12** This grid covers:  
**Starter Motor**

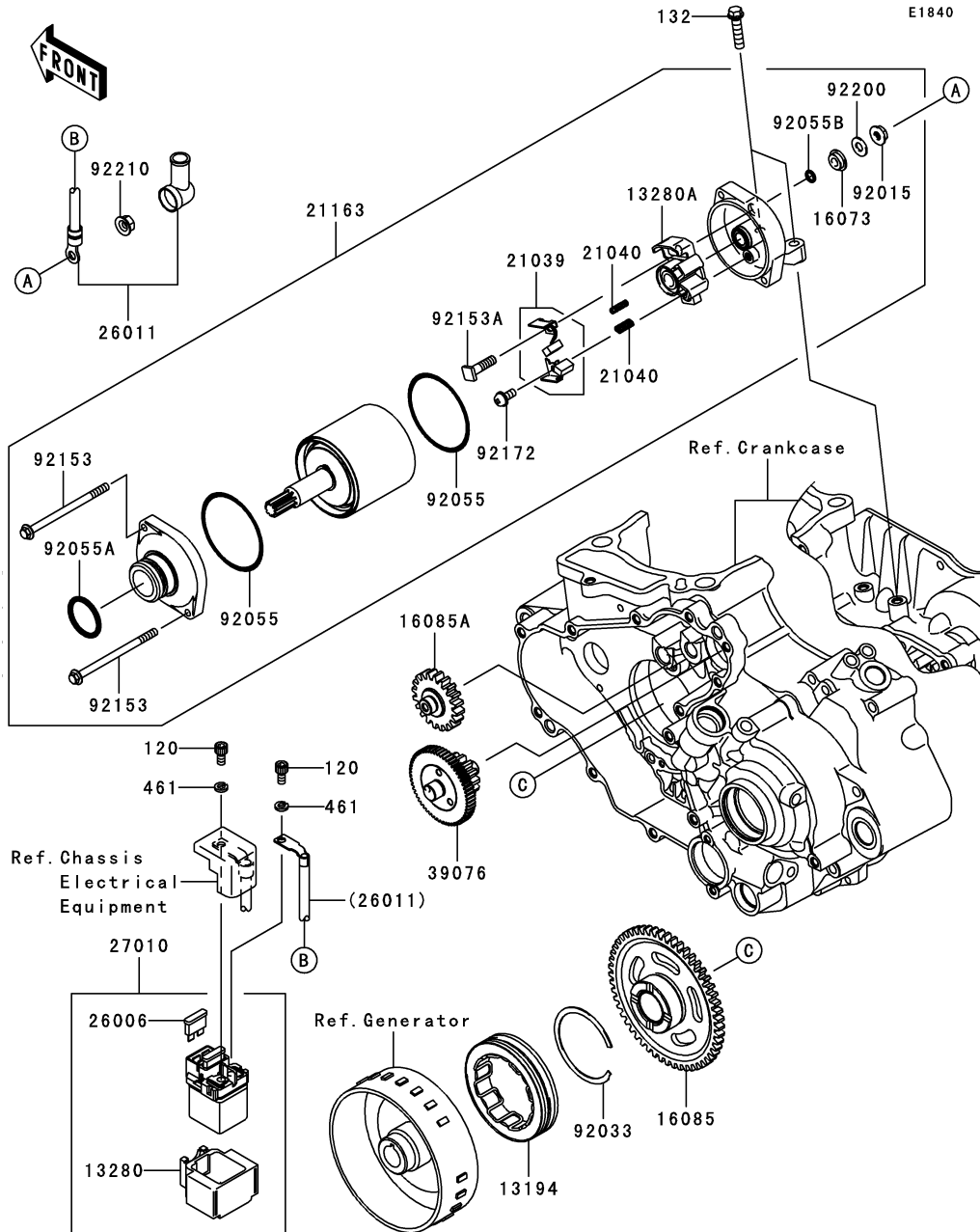

Ref. No.	Part No.	Description	Spec Code	Quantity-KSF450	
				'08	B8F
13194	13194-0008	CLUTCH-ONEWAY		1	
13280	13280-0109	HOLDER, SWITCH		1	
13280A	13280-0261	HOLDER		1	
16073	16073-0053	INSULATOR		1	
16085	16085-0092	GEAR, 53T		1	
16085A	16085-0093	GEAR, 20T		1	
21039	21039-0005	BRUSH, CARBON SET		1	
21040	21040-0003	SPRING-BRUSH		2	
21163	21163-0033	STARTER-ELECTRIC		1	
26006	26006-1006	FUSE, 30A-G		1	
26011	26011-0103	WIRE-LEAD		1	
27010	27010-0030	SWITCH, MAGNETIC		1	
39076	39076-0009	LIMITER, 58T&13T		1	
92015	92015-1476	NUT, STARTER MOTOR		1	
92033	92033-3731	RING-SNAP		1	
92055	92055-0136	RING-O		2	
92055A	92055-1276	RING-O		1	
92055B	92055-1370	RING-O, 4.5X2.0		1	
92153	92153-1851	BOLT, SET		2	
92153A	92153-1866	BOLT		1	
92172	92172-0334	SCREW		1	
92200	92200-0386	WASHER		1	
92210	92210-0188	NUT, 6MM		1	
120	120S0510	BOLT-SOCKET, 5X10		2	
132	132Y0625	BOLT-FLANGED-SMALL, 6X25		2	
461	461K0500	WASHER-SPRING, 5MM, BLACK		2	

This catalog covers:  
**'08 KSF450B8F Engine**

GRID NO. This grid covers:  
**C-13 Water Pump**

E3031

Ref. No.	Part No.	Description	Spec Code	Quantity-KSF450			
				'08			
				B8F			

11061	11061-0237	GASKET,W/P COVER		1
13107	13107-0135	SHAFT,WATER PUMP		1
16142	16142-0034	COVER-PUMP,WATER		1
59256	59256-0003	IMPELLER		1
92022	92022-304	WASHER,6.2X11X1		1
92151	92151-1546	BOLT,FLANGED,6X25		1
92151A	92151-1930	BOLT,FLANGED-SMALL,6X25		4
132	132L0608	BOLT-FLANGED-SMALL,6X8		1
480	480J1000	CIRCLIP-TYPE-C,10MM		1
610	610A0408	ROLLER,4X8		2

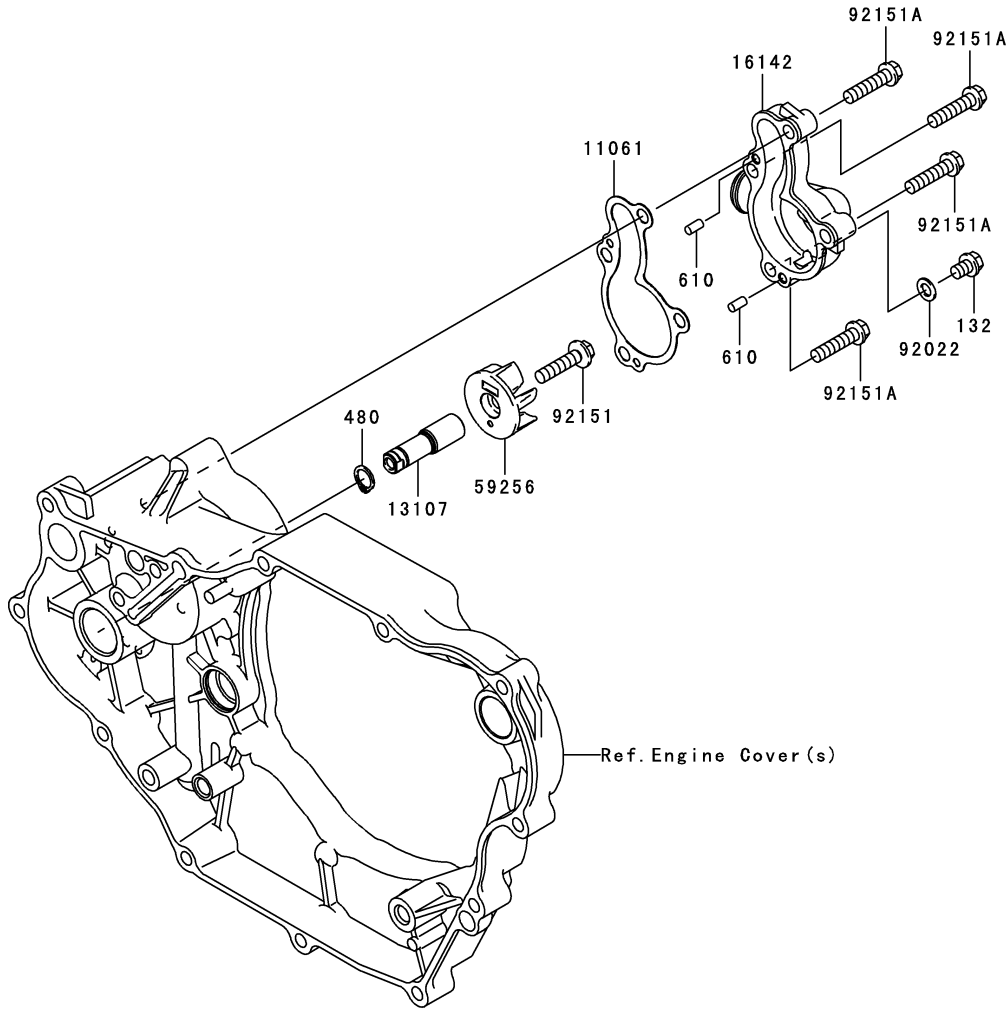

This catalog covers:

'08 KSF450B8F Engine

GRID NO.

**C-14**

This grid covers:

**Radiator**

E3032

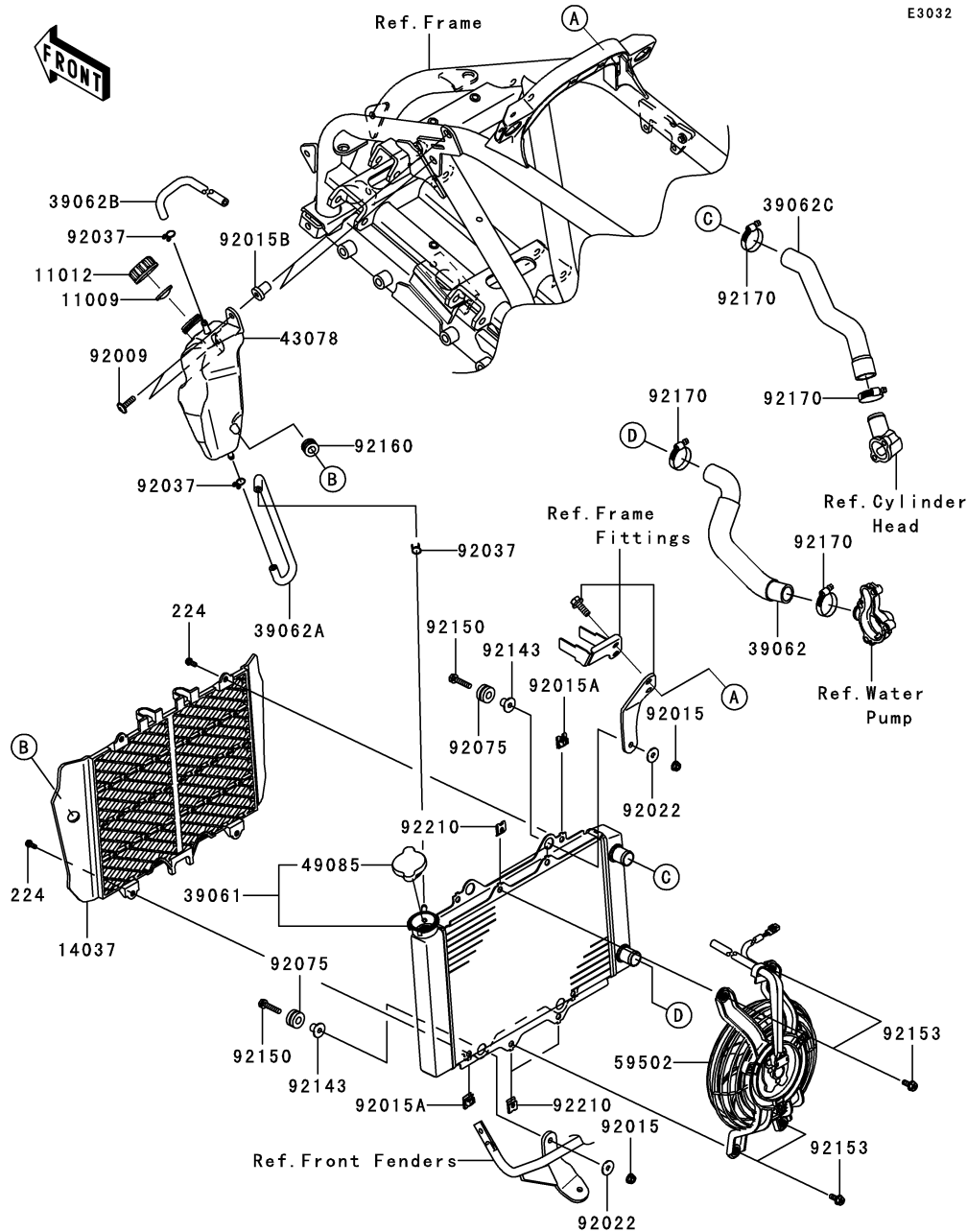

Ref. No.	Part No.	Description	Spec Code	Quantity-KSF450	
				'08	B8F
11009	11009-1145	GASKET,RESERVOIR TANK CAP		1	
11012	11012-1084	CAP		1	
14037	14037-0055	SCREEN,RADIATOR		1	
39061	39061-0125	RADIATOR-ASSY		1	
39062	39062-0146	HOSE-COOLING,W/P-RAD.		1	
39062A	39062-0201	HOSE-COOLING,RAD.-RESERVOIR		1	
39062B	39062-0202	HOSE-COOLING,BREATHER		1	
39062C	39062-0215	HOSE-COOLING,RAD.-HEAD		1	
43078	43078-0043	RESERVOIR		1	
49085	49085-0005	CAP-ASSY-PRESSURE		1	
59502	59502-0029	FAN-ASSY		1	
92009	92009-1465	SCREW,6X25		2	
92015	92015-1233	NUT,FLANGED,6MM,BLACK		4	
92015A	92015-1487	NUT		4	
92015B	92015-1692	NUT,RUBBER,6MM		2	
92022	92022-1346	WASHER,6.5X20X1.6,BLACK		4	
92037	92037-147	CLAMP,TUBE		3	
92075	92075-1901	DAMPER		4	
92143	92143-1353	COLLAR		4	
92150	92150-1694	BOLT,6X30		4	
92153	92153-1806	BOLT		4	
92160	92160-1167	DAMPER		1	
92170	92170-1497	CLAMP		4	
92210	92210-0377	NUT,6MM		4	
224	224C0614	SCREW-PAN-WP-CROS,6X14		4	

This catalog covers:

'08 KSF450B8F Chassis

GRID NO.

**D-3**

This grid covers:

**Frame**

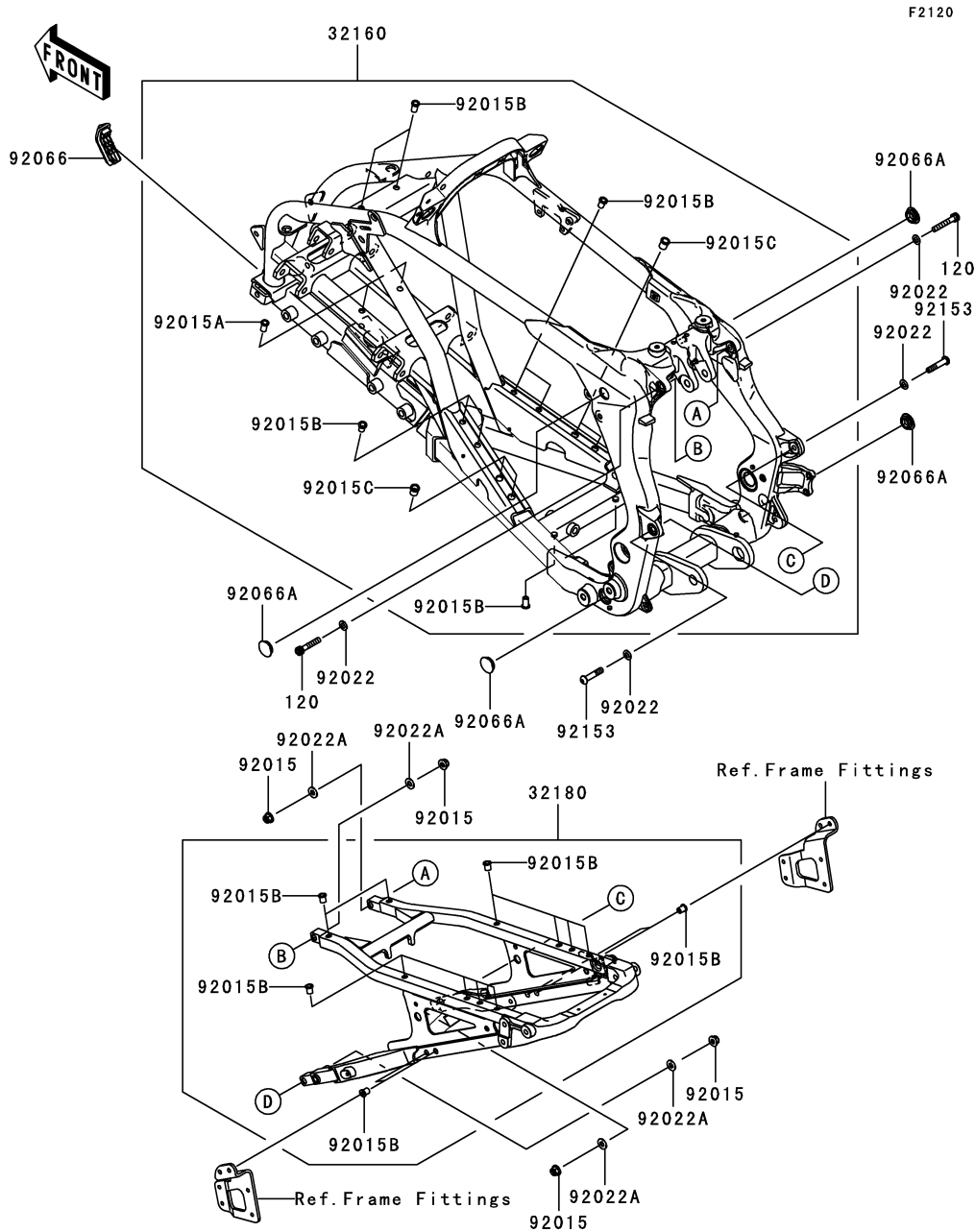

Ref. No.	Part No.	Description	Spec Code	Quantity-KSF450	
				'08	B8F
32160	32160-0170	FRAME-COMP			1
32180	32180-0001	FRAME-SUB-COMP			1
92015	92015-1432	NUT,8MM			4
92015A	92015-1759	NUT,POP,6MM			2
92015B	92015-1792	NUT,POP,6MM,L=16.5			22
92015C	92015-1794	NUT,POP,8MM,L=18			4
92022	92022-3043	WASHER,PLAIN,8MM			4
92022A	92022-3743	WASHER,8.2X18X1.5			4
92066	92066-0082-AG	PLUG,FRAME TOP,F.SILVER			1
92066A	92066-1534	PLUG			4
92153	92153-1659	BOLT,SOCKET,8X40			2
120	120CA0840	BOLT-SOCKET,8X40			2

This catalog covers:

'08 KSF450B8F Chassis

GRID NO.

**D-4**

This grid covers:

**Steering Shaft**

F2121

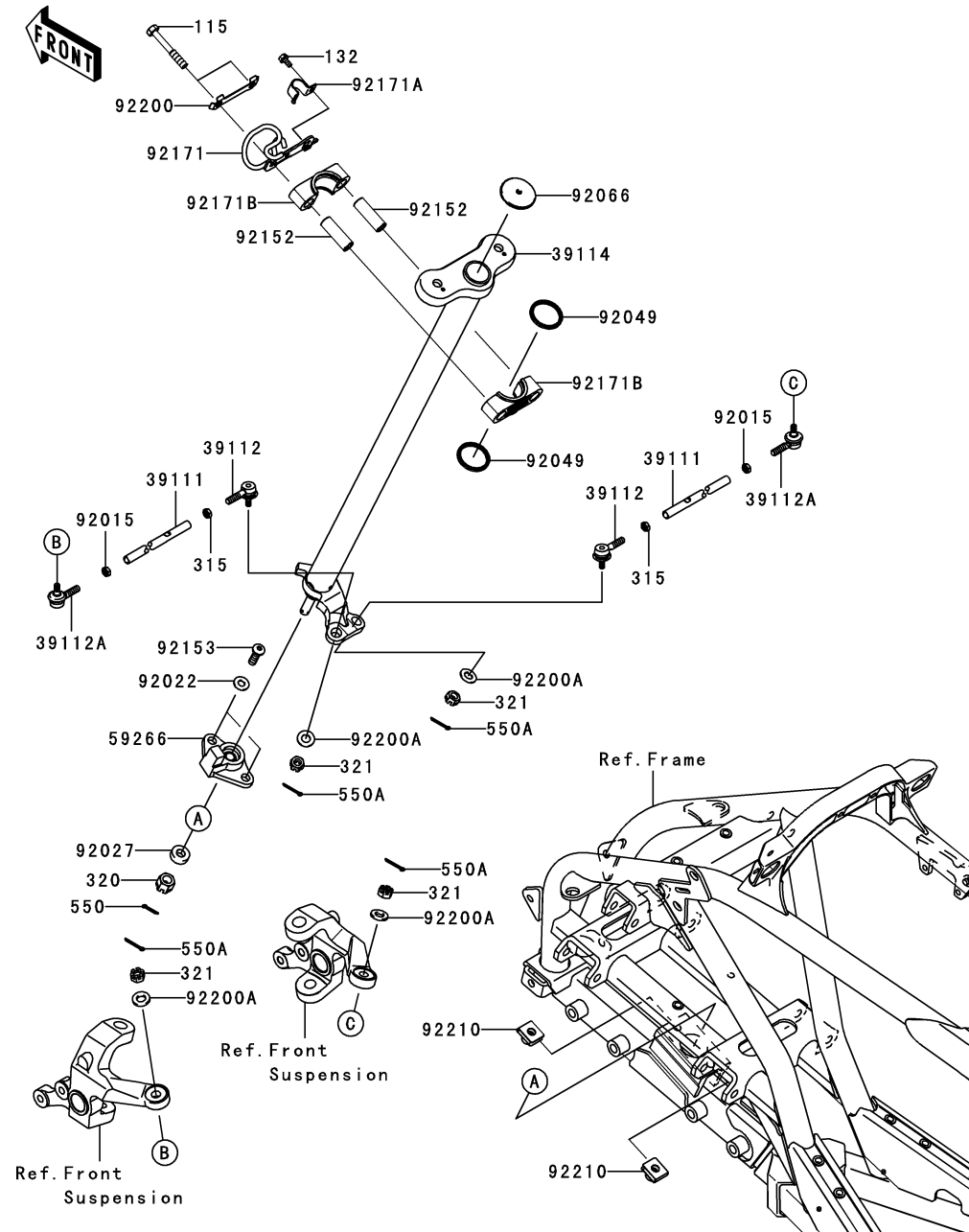

Ref. No.	Part No.	Description	Spec Code	Quantity-KSF450	
				'08	B8F
39111	39111-0052	ROD-TIE		2	
39112	39112-0011	RODEND-TIE,LEFT HANDED		2	
39112A	39112-0012	RODEND-TIE,RIGHT HANDED		2	
39114	39114-0012-21	SHAFT-COMP-STRG,F.BLACK		1	
59266	59266-0026	JOINT-BALL		1	
92015	92015-1532	NUT,12MM,LEFT SCREW		2	
92022	92022-3043	WASHER,PLAIN,8MM		2	
92027	92027-1817	COLLAR,10X21.3X7		1	
92049	92049-7501	SEAL-OIL,SR31.8X37.5X3.8LR		2	
92066	92066-0032	PLUG		1	
92152	92152-7501	COLLAR,9.1X13.95X42		2	
92153	92153-1838	BOLT,SOCKET,8X25		2	
92171	92171-0855	CLAMP,CABLE		1	
92171A	92171-0856	CLAMP,BRAKE HOSE		1	
92171B	92171-7501	CLAMP,STEERING		2	
92200	92200-0384	WASHER,STEERING CLAMP		1	
92200A	92200-0393	WASHER,10.7X20X2.5		4	
92210	92210-0376	NUT,8MM		2	
115	115S0855	BOLT-SMALL-UPSET,8X55		2	
132	132G0510	BOLT-FLANGED-SMALL,5X10		1	
315	315C1200	NUT-HEX-FINE		2	
320	320H1000	NUT-CASTLE		1	
321	321H1000	NUT-CASTLE		4	
550	550D2518	PIN-COTTER,2.5X18		1	
550A	550D2520	PIN-COTTER,2.5X20		4	

This catalog covers:

'08 KSF450B8F Chassis

GRID NO.

**D-5**

This grid covers:

**Frame Fittings(1/2)**

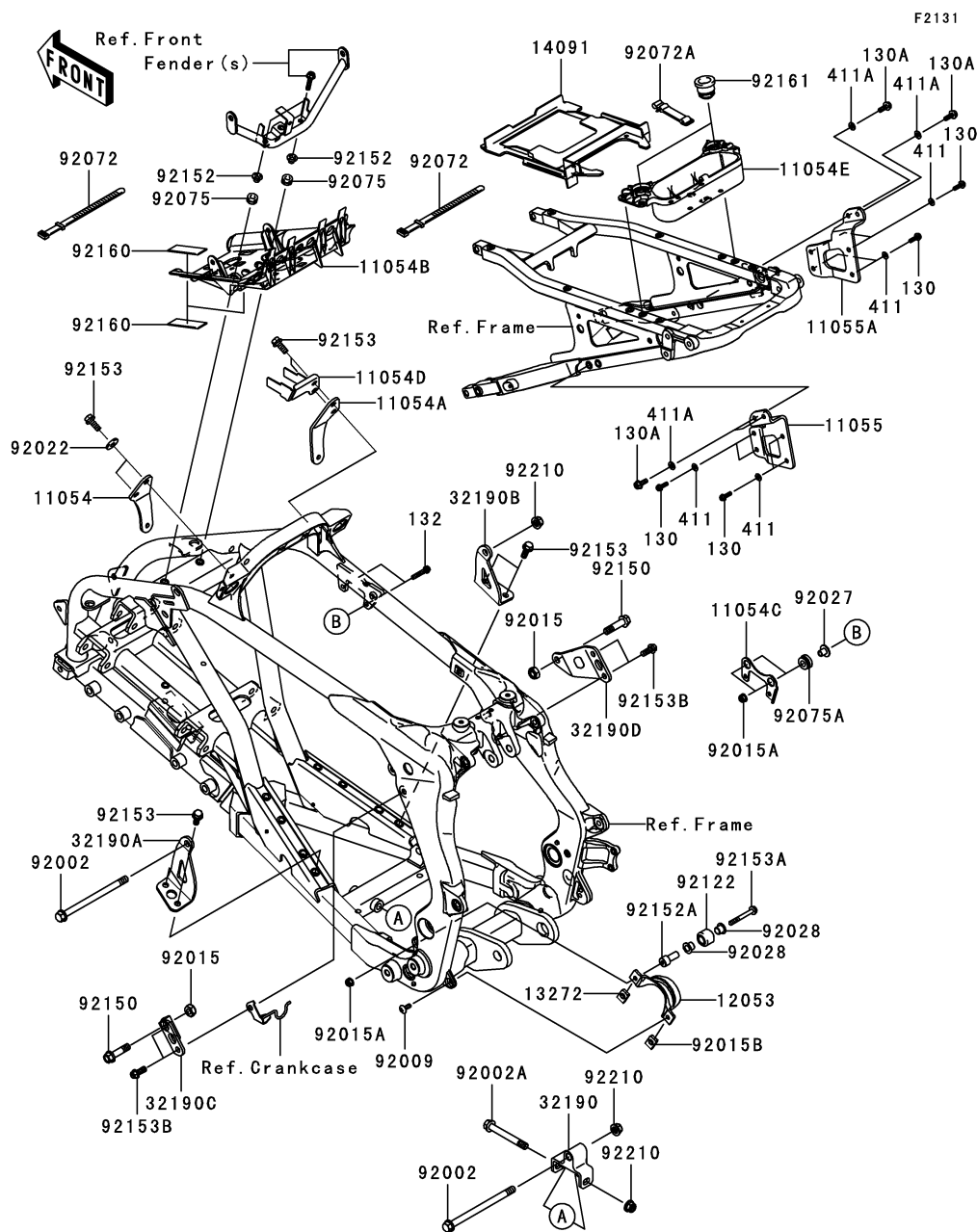

Ref. No.	Part No.	Description	Spec Code	Quantity-KSF450	
				'08	B8F
11054	11054-0279	BRACKET,PAD,UPP,LH		1	
11054A	11054-0280	BRACKET,PAD,UPP,RH		1	
11054B	11054-1710	BRACKET,ELECTRIC		1	
11054C	11054-1805	BRACKET,IGNITION COIL		1	
11054D	11054-1819	BRACKET		1	
11054E	11054-1881	BRACKET,TOOL CASE		1	
11055	11055-0070	BRACKET,AIR CLEANER BOX,LH		1	
11055A	11055-0071	BRACKET,AIR CLEANER BOX,RH		1	
12053	12053-0077	GUIDE-CHAIN		1	
13272	13272-0080	PLATE,CHAIN GUIDE		1	
14091	14091-0744	COVER,AIR CLEANER		1	
32190	32190-0281	BRACKET-ENGINE		1	
32190A	32190-0296	BRACKET-ENGINE,FR,LWR,LH		1	
32190B	32190-0297	BRACKET-ENGINE,FR,LWR,RH		1	
32190C	32190-0298	BRACKET-ENGINE,HEAD,LH		1	
32190D	32190-0299	BRACKET-ENGINE,HEAD,RH		1	
92002	92002-1348	BOLT,10X145		2	
92002A	92002-1576	BOLT,ARM,10MM		1	
92009	92009-3830	SCREW,6X15		1	
92015	92015-1189	NUT,LOCK,10MM,BLACK		2	
92015A	92015-1339	NUT,LOCK,FLANGED,6MM		3	
92015B	92015-1602	NUT,6MM		1	
92022	92022-3744	WASHER,8.4X23X2.5		2	
92027	92027-1651	COLLAR,FLANGED,L=12.1,BLACK		2	
92028	92028-1507	BUSHING		2	
92072	92072-056	BAND,L=186		2	
92072A	92072-1085	BAND		1	
92075	92075-1912	DAMPER		2	
92075A	92075-277	DAMPER		2	
92122	92122-0020	ROLLER		1	
92150	92150-1711	BOLT,FLANGED,10X40		2	
92152	92152-0237	COLLAR		2	
92152A	92152-0585	COLLAR		1	
92153	92153-0892	BOLT,8X20		8	
92153A	92153-0925	BOLT,6X50,WHITE		1	
92153B	92153-0995	BOLT,FLANGED,8X20		4	
92160	92160-1075	DAMPER		6	
92161	92161-0048	DAMPER		2	
92210	92210-1080	NUT,LOCK,FLANGED,10MM		3	
130	130G0516	BOLT-FLANGED,5X16		8	

This catalog covers:

'08 KSF450B8F Chassis

GRID NO.

D-6

This grid covers:

Frame Fittings(2/2)

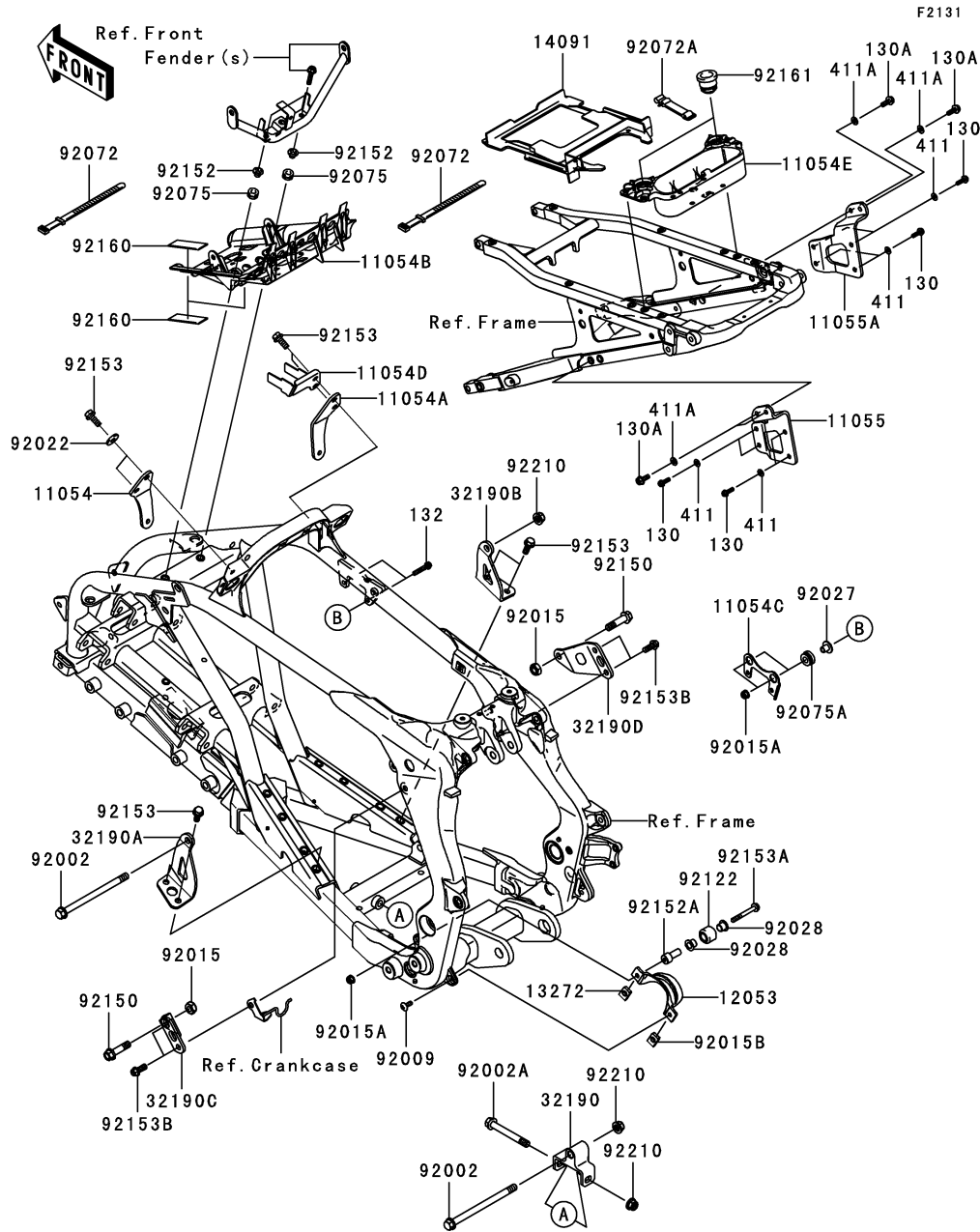

Ref. No.	Part No.	Description	Spec Code	Quantity-KSF450	
				'08	B8F
130A	130G0616	BOLT-FLANGED,6X16		4	
132	132G0630	BOLT-FLANGED-SMALL,6X30		2	
411	411B0500	WASHER-PLAIN,5MM		8	
411A	411B0600	WASHER-PLAIN,6MM		4	



This catalog covers:

'08 KSF450B8F Chassis

GRID NO.

**D-8**

This grid covers:

**Swingarm**

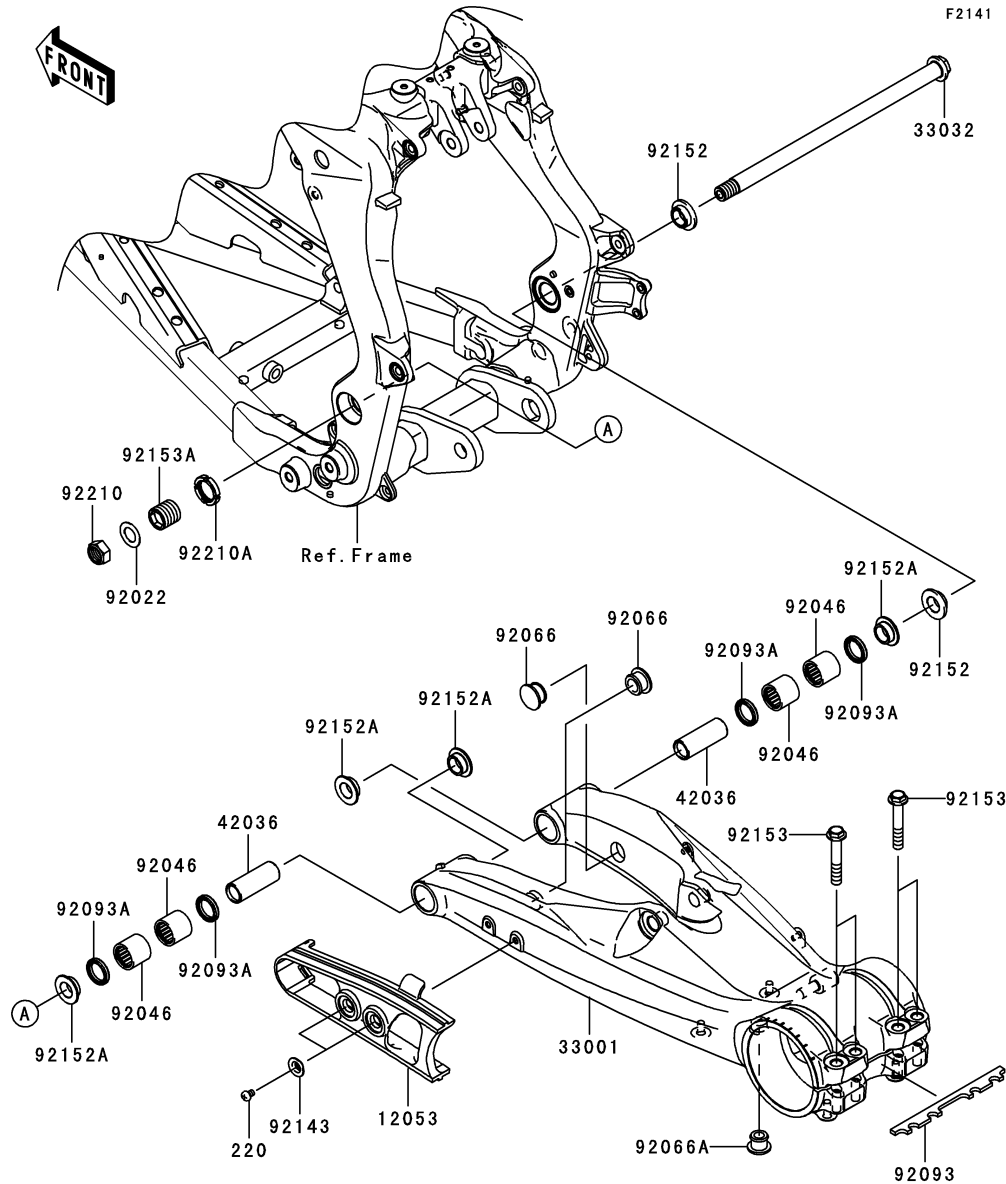

Ref. No.	Part No.	Description	Spec Code	Quantity-KSF450	
				'08	B8F
12053	12053-0100	GUIDE-CHAIN		1	
33001	33001-0105	ARM-COMP-SWING		1	
33032	33032-0019	SHAFT-SWING ARM		1	
42036	42036-0036	SLEEVE		2	
92022	92022-170	WASHER,THRUST,16.5X28X1		1	
92046	92046-0027	BEARING-NEEDLE,BM222925		4	
92066	92066-0074	PLUG		2	
92066A	92066-0077	PLUG		1	
92093	92093-0062	SEAL		1	
92093A	92093-1435	SEAL,SDO22X29X5		4	
92143	92143-1156	COLLAR		2	
92152	92152-0402	COLLAR		2	
92152A	92152-0431	COLLAR		4	
92153	92153-1486	BOLT,FLANGED,10X60		4	
92153A	92153-1600	BOLT,PIVOT,24MM		1	
92210	92210-0179	NUT,LOCK,16MM		1	
92210A	92210-0294	NUT,PIVOT,24MM		1	
220	220B0608	SCREW-PAN-CROS,6X8		2	

This catalog covers:

'08 KSF450B8F Chassis

GRID NO.

**D-9**

This grid covers:

**Front Suspension**

F2152

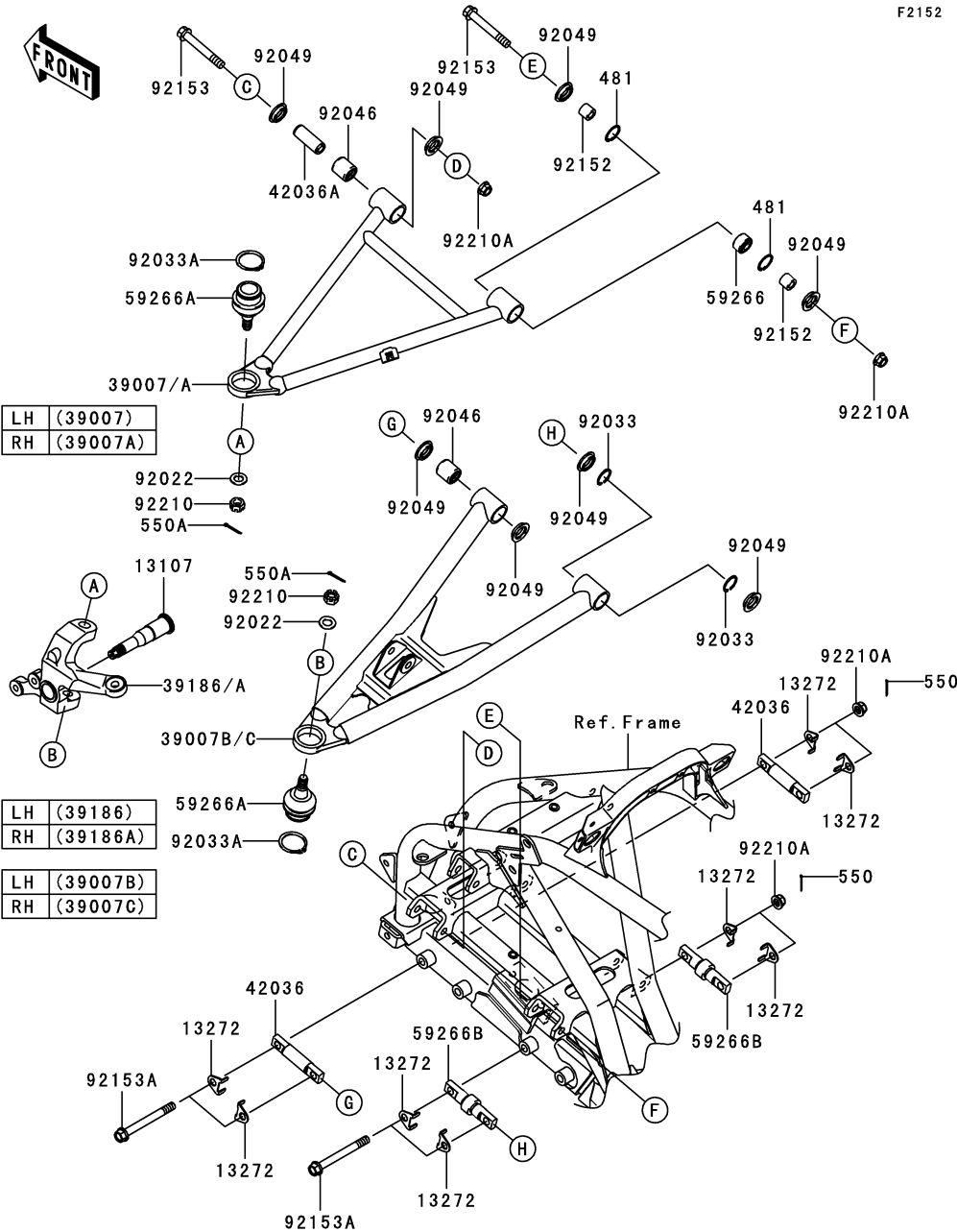

Ref. No.	Part No.	Description	Spec Code	Quantity-KSF450			
				'08			

13107	13107-0159	SHAFT,FRONT AXLE		2
13272	13272-0081	PLATE		8
39007	39007-0070-16H	ARM-SUSP,FR,UPP,LH,SILVER		1
39007A	39007-0071-16H	ARM-SUSP,FR,UPP,RH,SILVER		1
39007B	39007-0091-16H	ARM-SUSP,FR,LWR,LH,SILVER		1
39007C	39007-0092-16H	ARM-SUSP,FR,LWR,RH,SILVER		1
39186	39186-0076	KNUCKLE,LH		1
39186A	39186-0077	KNUCKLE,RH		1
42036	42036-0037	SLEEVE		2
42036A	42036-1376	SLEEVE		2
59266	59266-0013	JOINT-BALL		2
59266A	59266-0014	JOINT-BALL		4
59266B	59266-0015	JOINT-BALL		2
92022	92022-1065	WASHER, 12.3X22X1.6		4
92033	92033-0046	RING-SNAP		4
92033A	92033-1262	RING-SNAP,C-TYPE,32MM		4
92046	92046-1046	BEARING-NEEDLE		4
92049	92049-1223	SEAL-OIL,MHA17245.7F		16
92152	92152-1455	COLLAR, 10X17X14.5		4
92153	92153-1606	BOLT,FLANGED,10X70		4
92153A	92153-1859	BOLT,FLANGED,10X95		4
92210	92210-0395	NUT,CASTLE, 12MM		4
92210A	92210-1080	NUT,LOCK,FLANGED,10MM		8
481	481J2400	CIRCLIP		4
550	550D2520	PIN-COTTER,2.5X20		4
550A	550D3025	PIN-COTTER,3.0X25		4



This catalog covers:

'08 KSF450B8F Chassis

GRID NO.

**D-11**

This grid covers:

**Footrests**

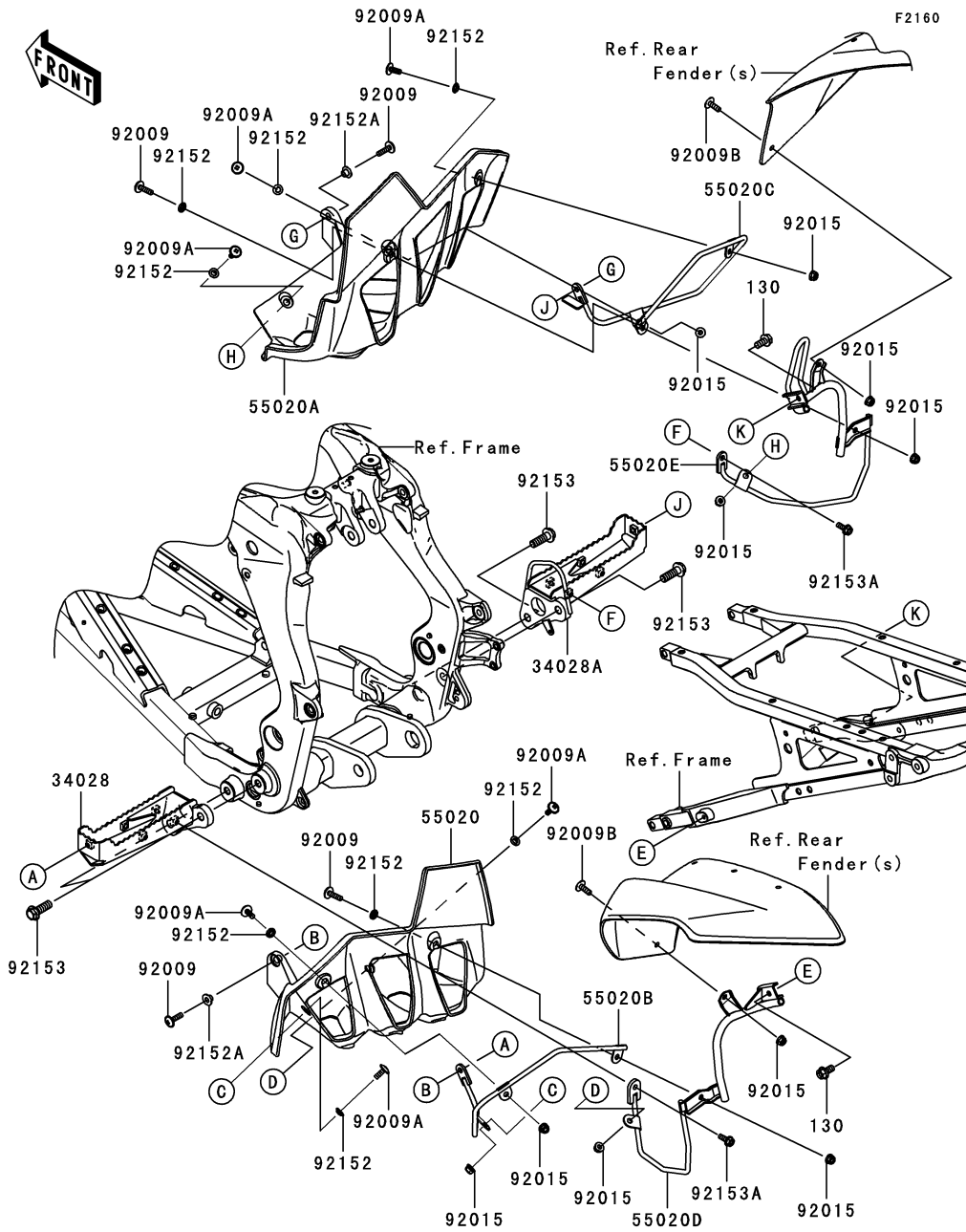

Ref. No.	Part No.	Description	Spec Code	Quantity-KSF450	
				'08	B8F
34028	34028-0080	STEP,LH			1
34028A	34028-0081	STEP,RH			1
55020	55020-0221-6Z	GUARD,FOOT GUARD,LH,F.BLACK			1
55020A	55020-0222-6Z	GUARD,FOOT GUARD,RH,F.BLACK			1
55020B	55020-0223	GUARD,SUB,LH			1
55020C	55020-0226	GUARD,SUB,RH			1
55020D	55020-0327	GUARD,MAIN,LH			1
55020E	55020-0328	GUARD,MAIN,RH			1
92009	92009-1256	SCREW,6X22,BLACK			4
92009A	92009-1621	SCREW,6X16			6
92009B	92009-1663	SCREW,6X18			2
92015	92015-1603	NUT,LOCK,FLANGED,6MM			10
92152	92152-0250	COLLAR			8
92152A	92152-0286	COLLAR			2
92153	92153-0801	BOLT,FLANGED,10X30			4
92153A	92153-1551	BOLT,FLANGED,6X16			2
130	130J0816	BOLT-FLANGED,8X16			2

This catalog covers:

'08 KSF450B8F Chassis

GRID NO.

**D-12**

This grid covers:

**Front Fender(s)**

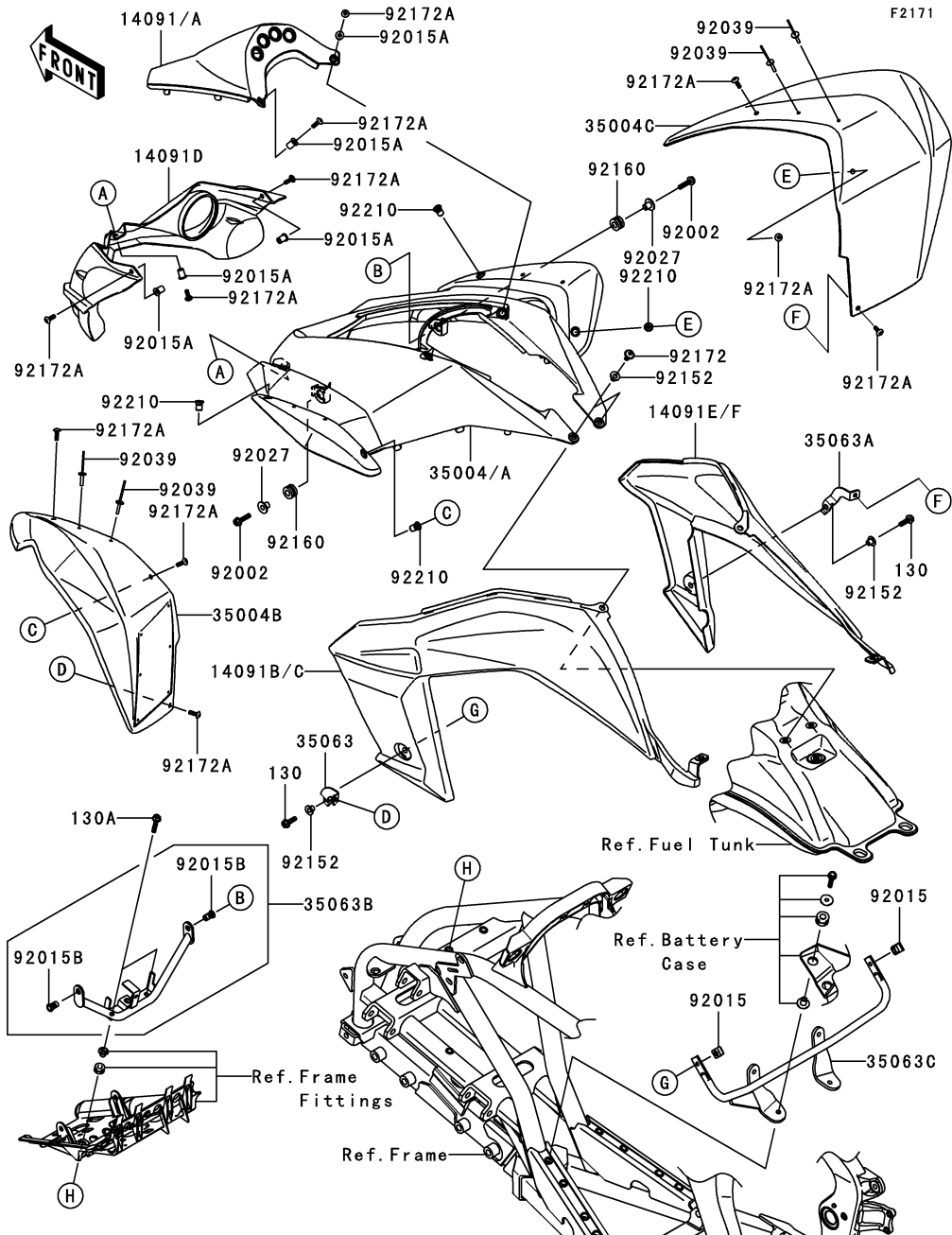

Ref. No.	Part No.	Description	Spec Code	Quantity-KSF450	
				'08	B8F
14091	14091-0554-266	COVER,MAINTENANCE,B.WHITE		1	
14091A	14091-0554-839	COVER,MAINTENANCE,BLACK			
	L-----		EU	1	
14091B	14091-0555-266	COVER,SIDE,LH,B.WHITE			
	L-----		EU	1	
14091C	14091-0555-290	COVER,SIDE,LH,L.GREEN		1	
14091D	14091-0557-6Z	COVER,HEAD LAMP COVER,F.BLACK		1	
14091E	14091-0793-266	COVER,SIDE,RH,B.WHITE			
	L-----		EU	1	
14091F	14091-0793-290	COVER,SIDE,RH,L.GREEN		1	
35004	35004-0067-266	FENDER-FRONT,MAIN,B.WHITE			
	L-----		EU	1	
35004A	35004-0067-290	FENDER-FRONT,MAIN,L.GREEN		1	
35004B	35004-0068-839	FENDER-FRONT,OUTER,LH,BLACK		1	
35004C	35004-0069-839	FENDER-FRONT,OUTER,RH,BLACK		1	
35063	35063-0398	STAY,FRONT FENDER,LH		1	
35063A	35063-0399	STAY,FRONT FENDER,RH		1	
35063B	35063-0426	STAY,FRONT FENDER,MAIN		1	
35063C	35063-0457	STAY,FRONT FENDER,OUTER		1	
92002	92002-1339	BOLT,6X25		2	
92015	92015-1602	NUT,6MM		2	
92015A	92015-1757	NUT,WELL,5MM		5	
92015B	92015-1792	NUT,POP,6MM,L=16.5		2	
92027	92027-1651	COLLAR,FLANGED,L=12.1,BLACK		2	
92039	92039-0039	RIVET		4	
92152	92152-0237	COLLAR		4	
92160	92160-1167	DAMPER		2	
92172	92172-0107	SCREW,6X14		2	
92172A	92172-0292	SCREW,5MM		11	
92210	92210-0370	NUT,WELL,5MM		4	
130	130G0620	BOLT-FLANGED,6X20		2	
130A	130P0625	BOLT-FLANGED,6X25		2	

This catalog covers:

'08 KSF450B8F Chassis

GRID NO.

**D-13**

This grid covers:

**Rear Fender(s)**

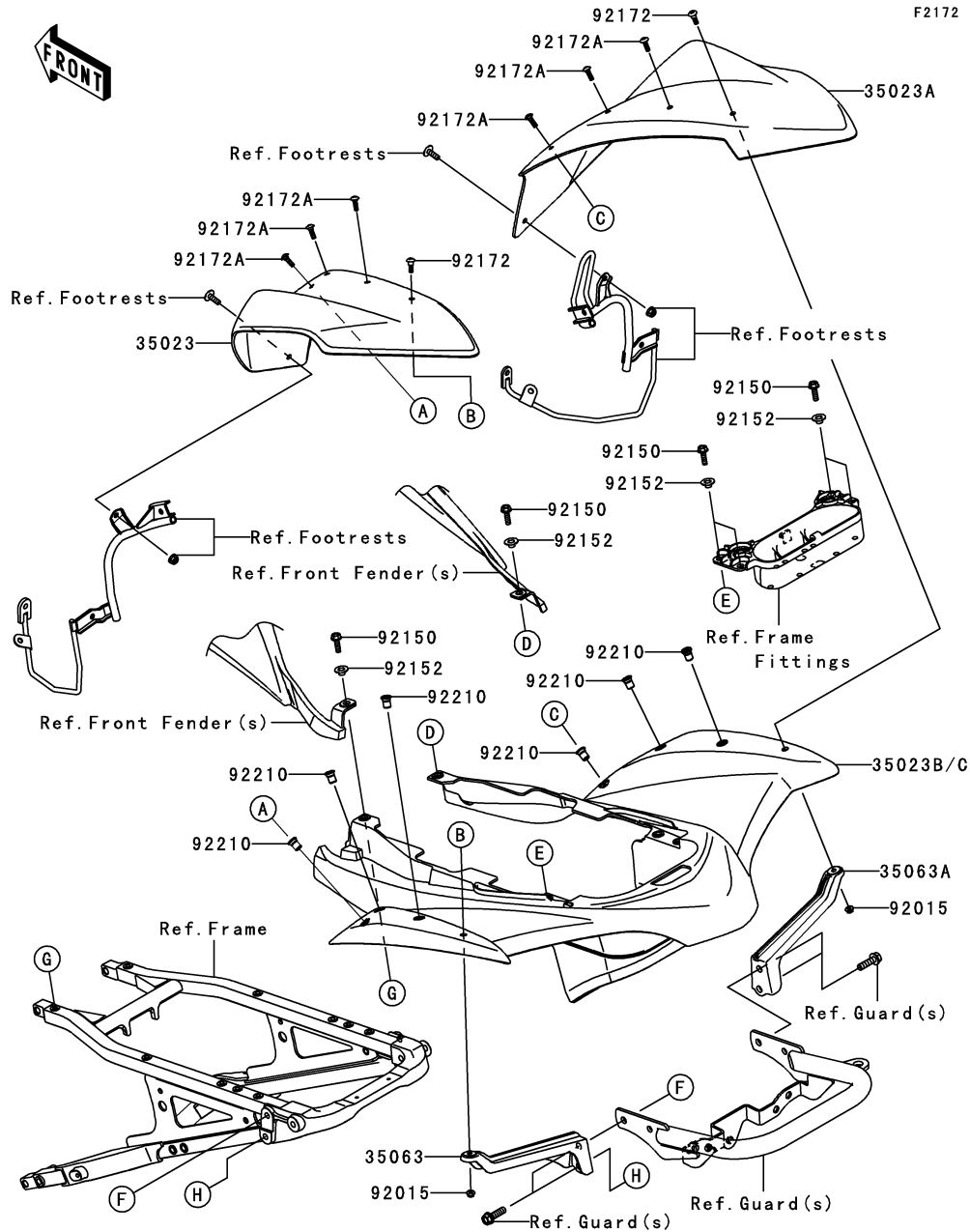

Ref. No.	Part No.	Description	Spec Code	Quantity-KSF450	
				'08	B8F
35023	35023-0081-839	FENDER-REAR, OUTER, LH, BLACK		1	
35023A	35023-0082-839	FENDER-REAR, OUTER, RH, BLACK		1	
35023B	35023-0113-266	FENDER-REAR, MAIN, B, WHITE			
		L-----EU		1	
35023C	35023-0113-290	FENDER-REAR, MAIN, L, GREEN		1	
35063	35063-0290	STAY, REAR FENDER, LH		1	
35063A	35063-0291	STAY, REAR FENDER, RH		1	
92015	92015-1752	NUT, LOCK, FLANGED, 5MM		2	
92150	92150-1014	BOLT, 6X20		6	
92152	92152-0401	COLLAR		6	
92172	92172-0261	SCREW, 5MM		2	
92172A	92172-0292	SCREW, 5MM		6	
92210	92210-0370	NUT, WELL, 5MM		6	

This catalog covers:

'08 KSF450B8F Chassis

GRID NO. This grid covers:

**D-14** Tires

F2210

Ref. No.	Part No.	Description	Spec Code	Quantity-KSF450			
				'08			
16126	16126-4001	VALVE				4	
41009	41009-0120	TIRE,FR,AT21X7R10,KT391(D)				2	
41009A	41009-0161	TIRE,RR,AT20X10R9,KT396(D)				2	
41025	41025-0070	RIM,FR,10X5.5AT				2	
41025A	41025-0071	RIM,RR,9X8AT				2	
92200	92200-1595	WASHER,10.5X25X1.6				16	
92210	92210-1325	NUT,FLANGED,10MM				16	

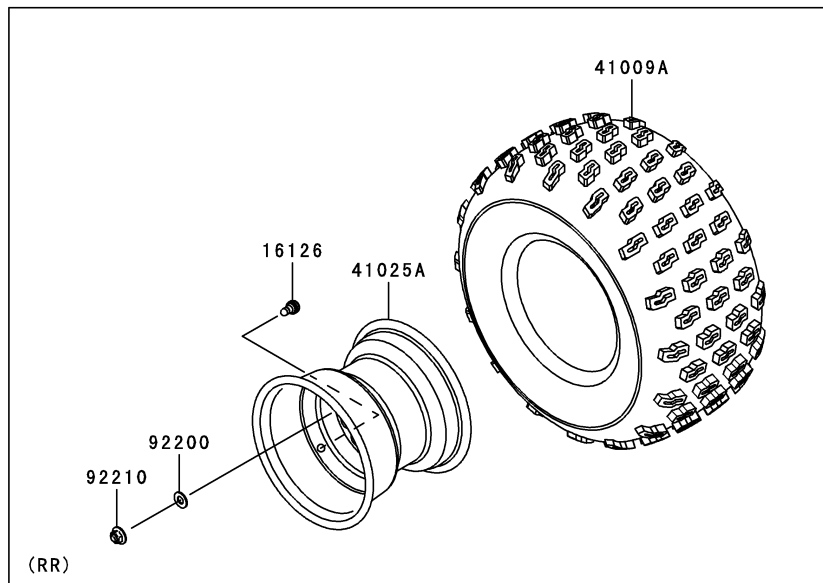
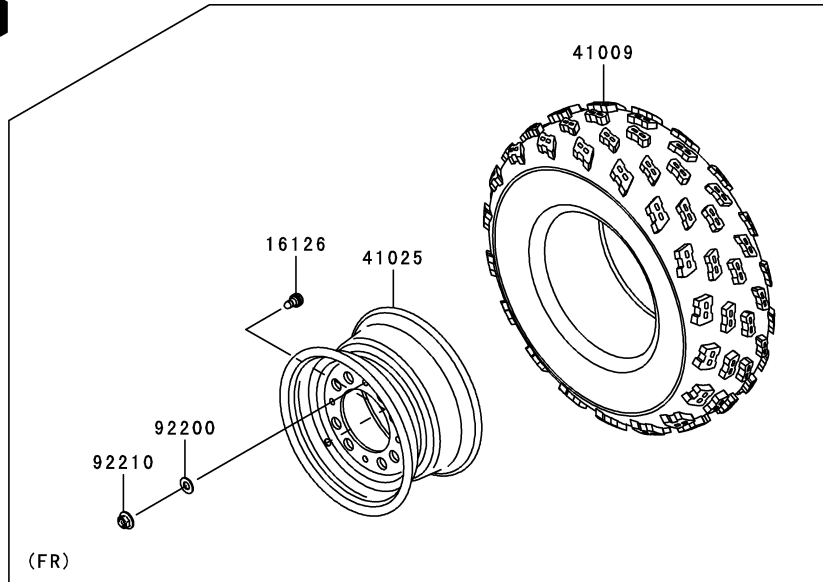



This catalog covers:

'08 KSF450B8F Chassis

GRID NO.

**E-4**

This grid covers:

**Rear Hub**

F2240

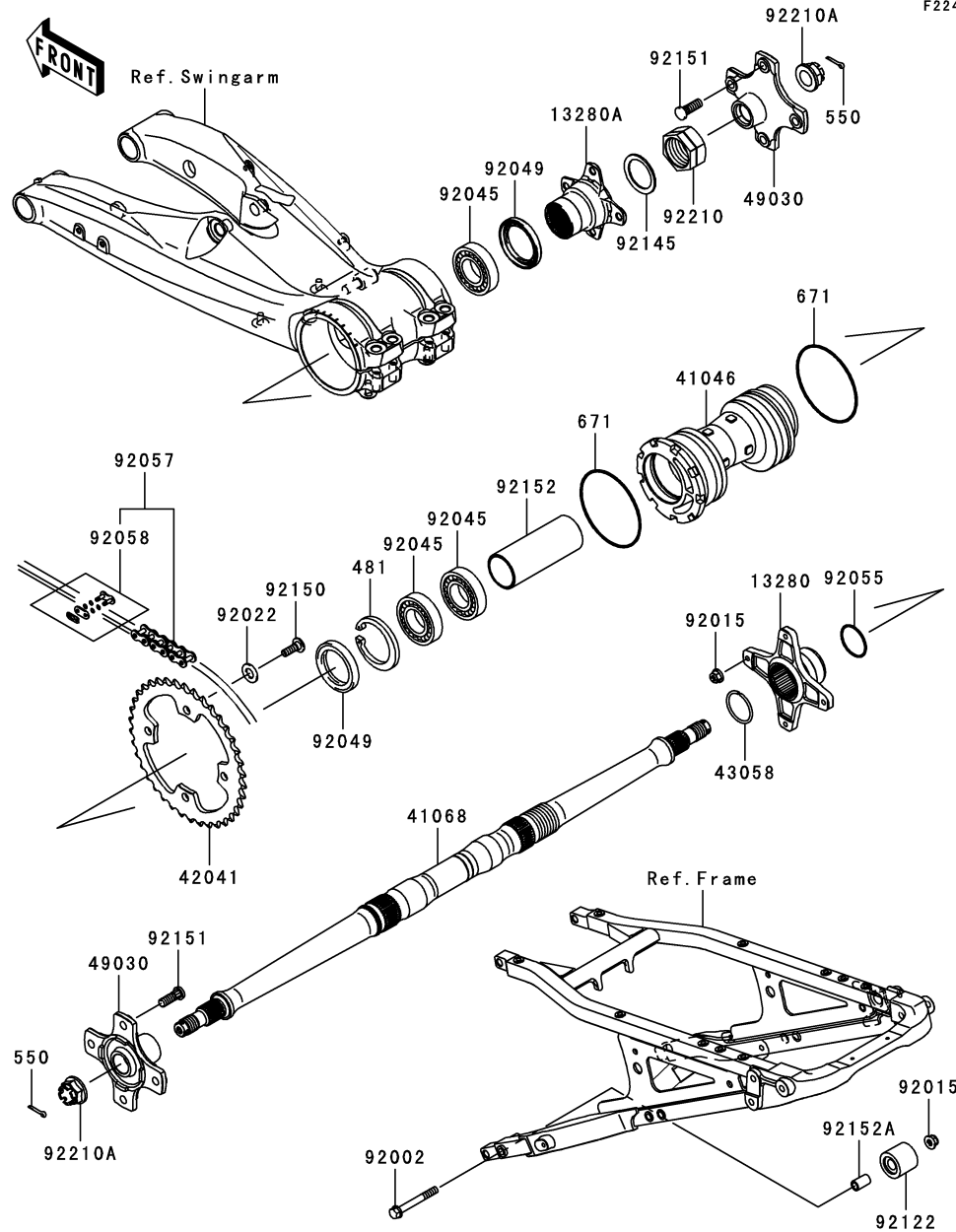

Ref. No.	Part No.	Description	Spec Code	Quantity-KSF450	
				'08	B8F
13280	13280-0175	HOLDER, SPROCKET		1	
13280A	13280-0176	HOLDER, REAR DISC		1	
41046	41046-0015	HOUSING-BEARING		1	
41068	41068-0052	AXLE, RR		1	
42041	42041-0044	SPROCKET-HUB, 38T		1	
43058	43058-0016	RING		1	
49030	49030-0029	HUB, RR		2	
92002	92002-1349	BOLT, FLANGED, 8X70		1	
92015	92015-1432	NUT, 8MM		5	
92022	92022-239	WASHER, 10.5X20X1		4	
92045	92045-0069	BEARING-BALL, 6908-82RSC3		3	
92049	92049-1573	SEAL-OIL, TCY 48X65X8		2	
92055	92055-520	RING-O, 35.2X1.9		1	
92057	92057-0119	CHAIN, DRIVE, EK520SR-O2X94L		1	
92058	92058-1060	JOINT-CHAIN, DRIVE, EK520SR-O2		1	
92122	92122-1216	ROLLER, CHAIN GUIDE		1	
92145	92145-0417	SPRING		1	
92150	92150-1858	BOLT, 8X25		4	
92151	92151-1392	BOLT, 10X29.5		8	
92152	92152-0405	COLLAR, 40X45.6X117.5		1	
92152A	92152-1340	COLLAR, 8.5X12.5X20.5		1	
92210	92210-0298	NUT, LOCK, 38MM		1	
92210A	92210-0299	NUT, CASTLE, 20MM		2	
481	481J6500	CIRCLIP-TYPE-C, 65MM		1	
550	550D4025	PIN-COTTER, 4.0X25		2	
671	671B2585	O RING, 85MM		2	

This catalog covers:  
**'08 KSF450B8F Chassis**

GRID NO. **E-5** This grid covers:  
**Brake Pedal**

F2260

Ref. No.	Part No.	Description	Spec Code	Quantity-KSF450			
				'08			
11054	11054-1271	BRACKET,BRAKE SWITCH SPRING		1			
13236	13236-0105	LEVER-COMP,BRAKE PEDAL		1			
92009	92009-3848	SCREW,6X20		1			
92144	92144-1266	SPRING		1			
92153	92153-1490	BOLT		1			
670	670B2012	O RING,12MM		2			

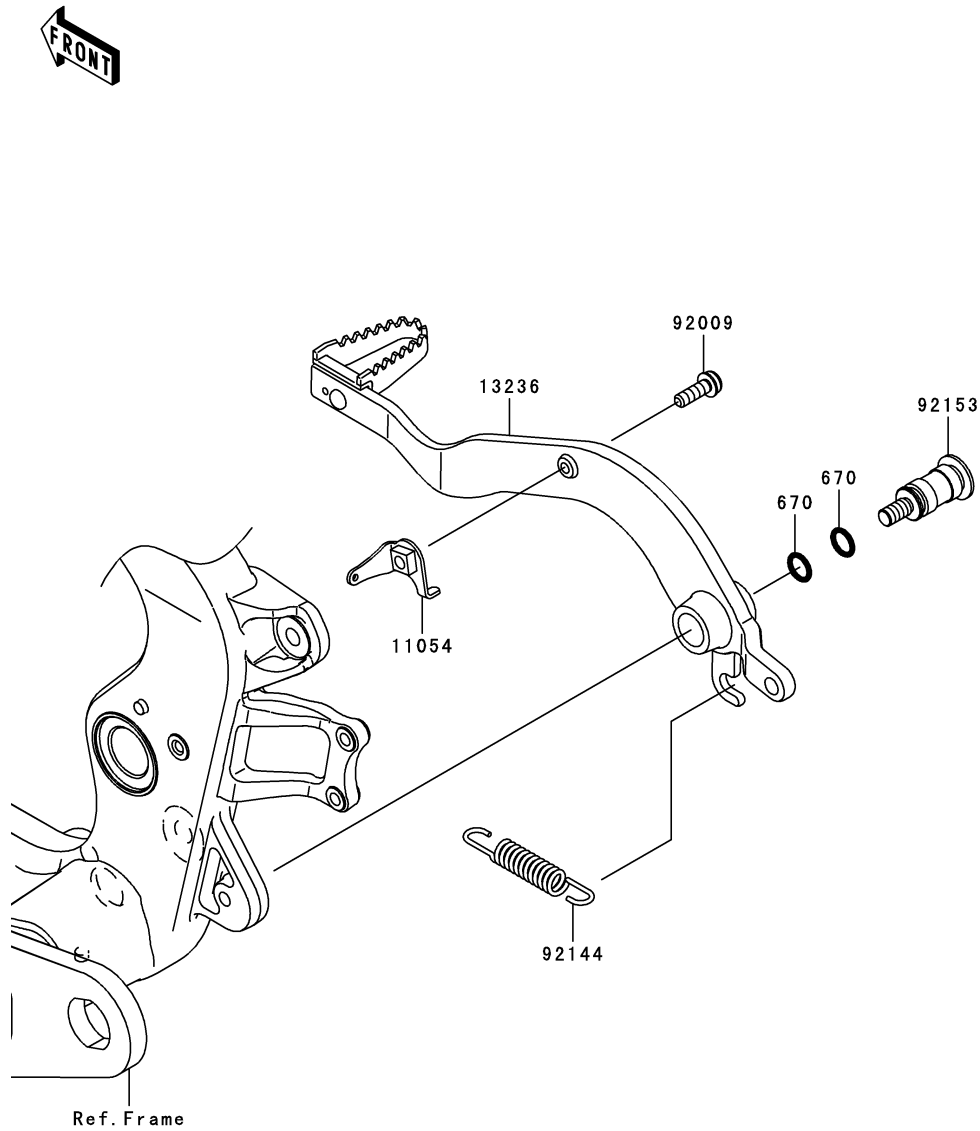

This catalog covers:

'08 KSF450B8F Chassis

GRID NO.

**E-6**

This grid covers:

**Shock Absorber(s)**

F2280

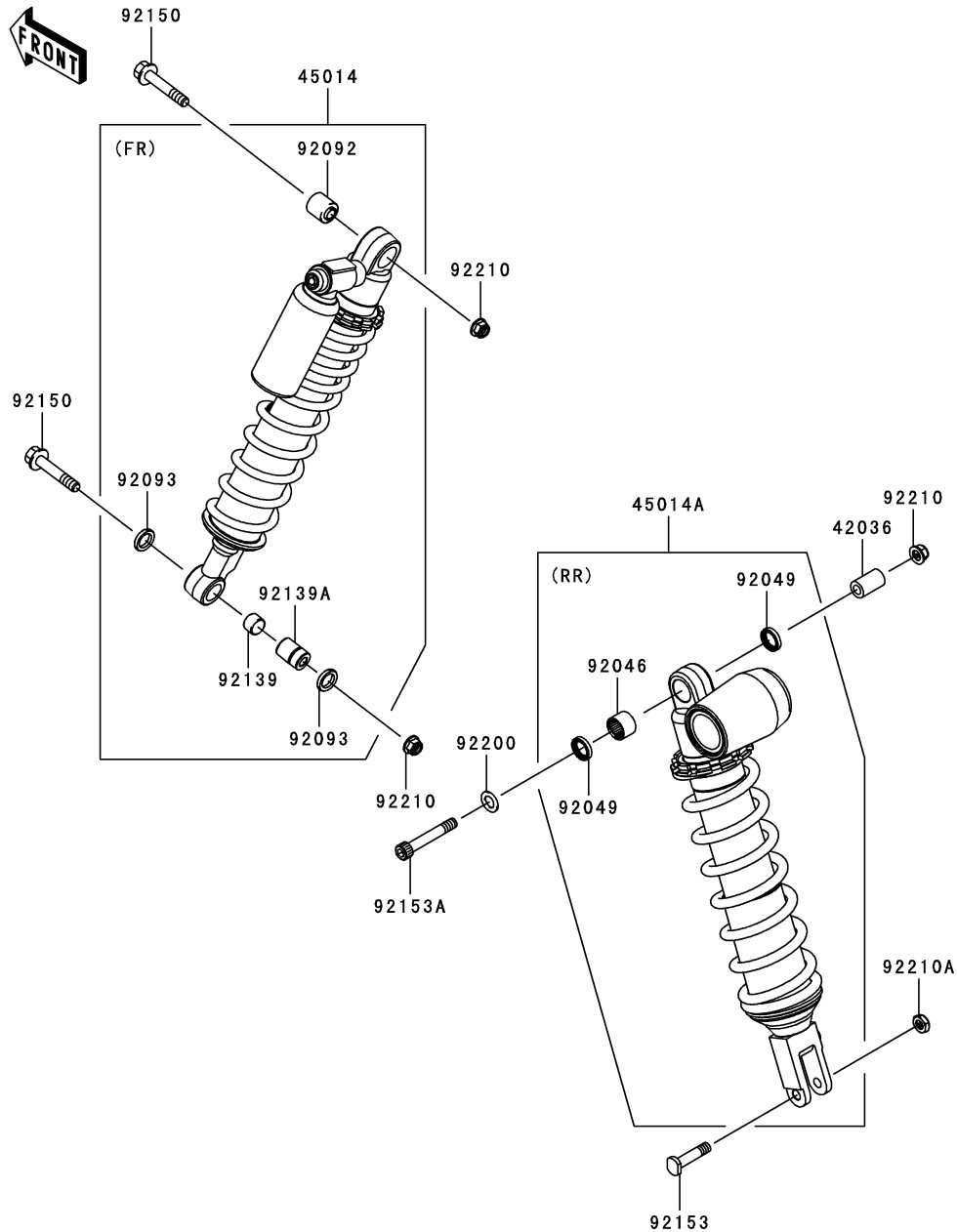

Ref. No.	Part No.	Description	Spec Code	Quantity-KSF450	
				'08	B8F
42036	42036-1258	SLEEVE,10.1X18X30		1	
45014	45014-0184-EH	SHOCKABSORBER,FR,PWHITE		2	
45014A	45014-0185-EH	SHOCKABSORBER,RR,PWHITE		1	
92046	92046-1272	BEARING-NEEDLE,SFYZM182417		1	
92049	92049-1225	SEAL-OIL,MHA18244		2	
92092	92092-1058	BUSHING-RUBBER		2	
92093	92093-0033	SEAL		4	
92139	92139-0084	BUSHING		2	
92139A	92139-0213	BUSHING		2	
92150	92150-1719	BOLT,FLANGED,10X51		4	
92153	92153-0937	BOLT,10X45		1	
92153A	92153-1705	BOLT,SOCKET,10X65		1	
92200	92200-0330	WASHER,10.6X18X1.2		1	
92210	92210-1080	NUT,LOCK,FLANGED,10MM		5	
92210A	92210-1184	NUT,LOCK,10MM		1	

This catalog covers:

'08 KSF450B8F Chassis

GRID NO.

**E-7**

This grid covers:

Front Master Cylinder

F2291

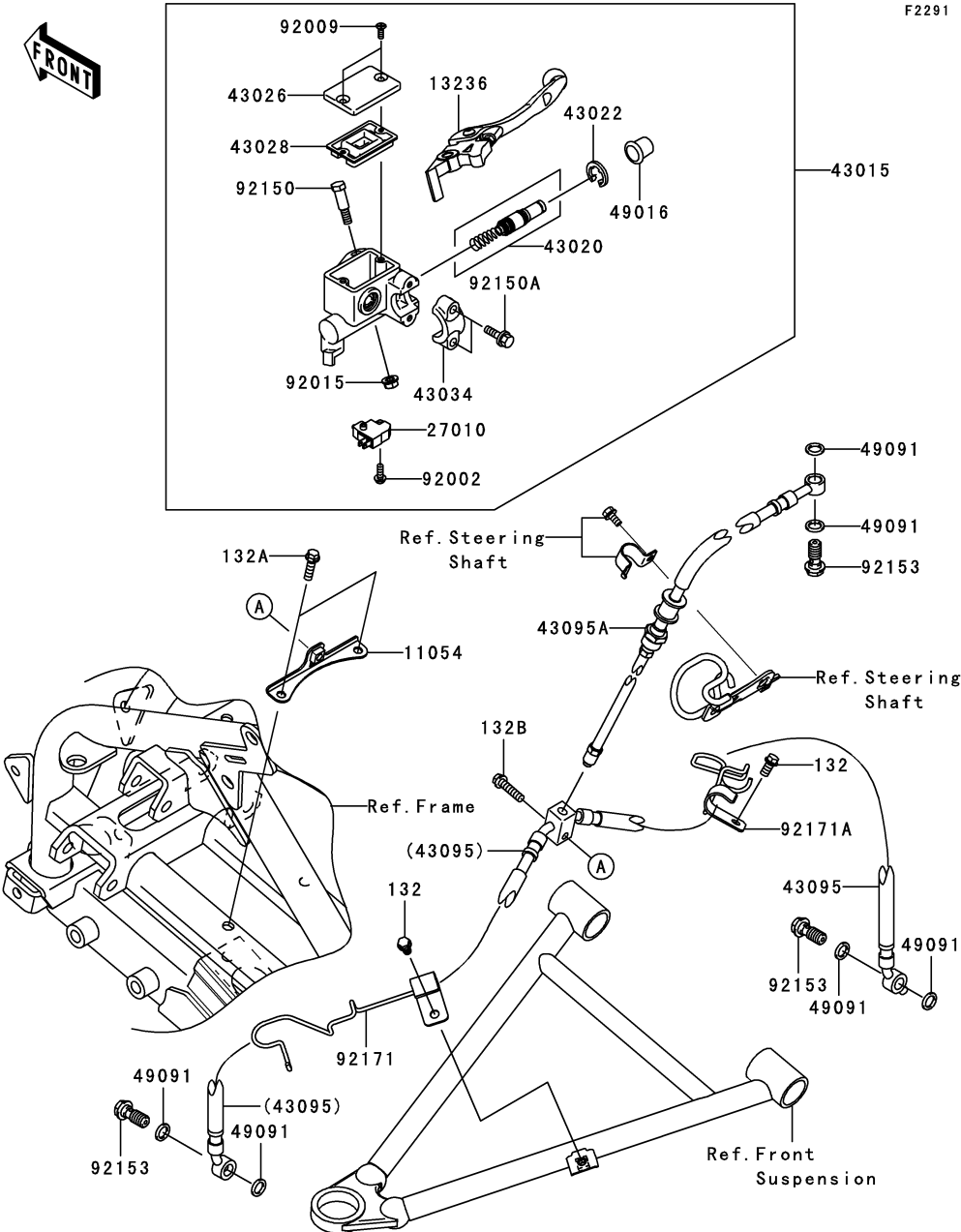

Ref. No.	Part No.	Description	Spec Code	Quantity-KSF450	
				'08	B8F
11054	11054-0291	BRACKET			1
13236	13236-0118	LEVER-COMP,FRONT BRAKE			1
27010	27010-0025	SWITCH,BRAKE			1
43015	43015-0070	CYLINDER-ASSY-MASTER,FR			1
43020	43020-1098	PISTON-COMP-BRAKE			1
43022	43022-1010	STOPPER-BRAKE,PISTON			1
43026	43026-0010	CAP-BRAKE			1
43028	43028-1061	DIAPHRAGM			1
43034	43034-1110	HOLDER-BRAKE			1
43095	43095-0326	HOSE-BRAKE			1
43095A	43095-0344	HOSE-BRAKE			1
49016	49016-1044	COVER-SEAL,MASTER CYLINDER			1
49091	49091-0001	WASHER-SEAL,10.1X14.5X1.5			6
92002	92002-1323	BOLT,SCREW,4X12			1
92009	92009-1795	SCREW			2
92015	92015-1528	NUT,FLANGED,6MM			1
92150	92150-1451	BOLT,LEVER SET			1
92150A	92150-1452	BOLT			2
92153	92153-0627	BOLT,OIL,L=23			3
92171	92171-0890	CLAMP,LH			1
92171A	92171-0891	CLAMP,RH			1
132	132J0612	BOLT-FLANGED-SMALL,6X12			2
132A	132J0620	BOLT-FLANGED-SMALL,6X20			2
132B	132J0625	BOLT-FLANGED-SMALL,6X25			1

This catalog covers:

'08 KSF450B8F Chassis

GRID NO.

**E-8**

This grid covers:

**Front Brake**

F2292

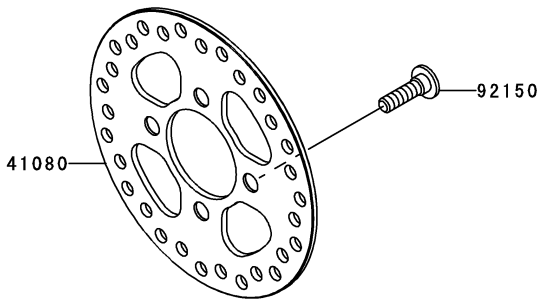
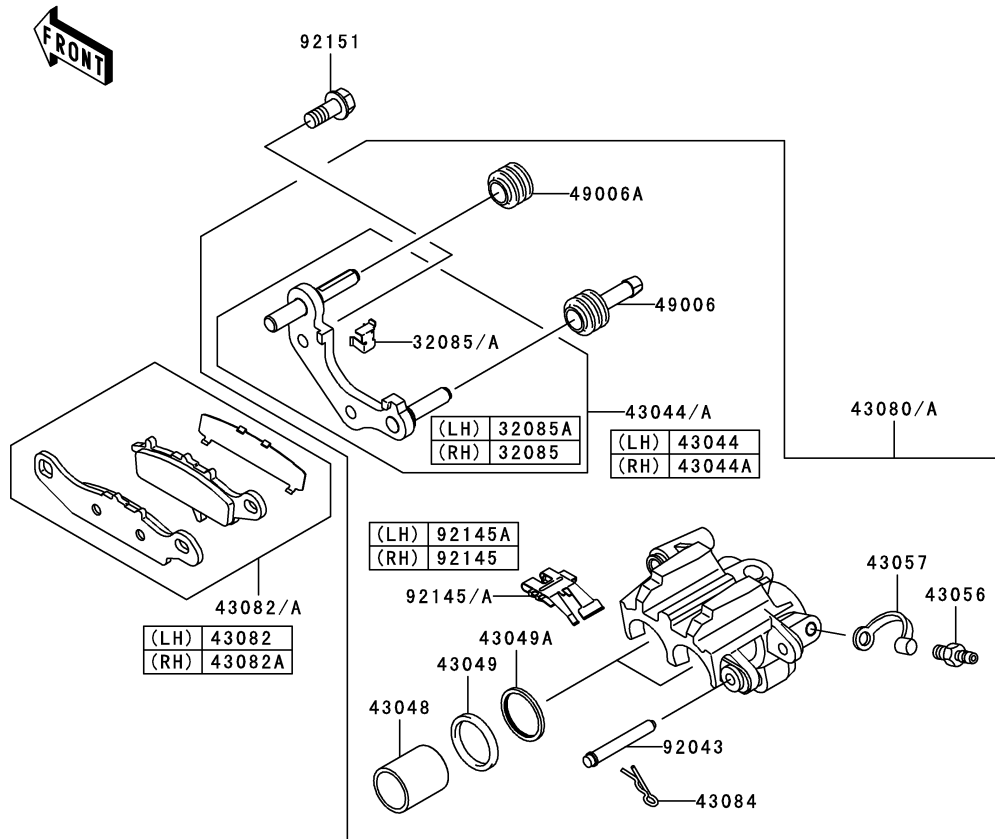

Ref. No.	Part No.	Description	Spec Code	Quantity-KSF450			
				'08			
				B8F			
32085	32085-1437	STOPPER,RH					1
32085A	32085-1517	STOPPER,LH					1
41080	41080-1534	DISC,FR					2
43044	43044-0010	HOLDER-COMP-CALIPER,FR,LH					1
43044A	43044-0011	HOLDER-COMP-CALIPER,FR,RH					1
43048	43048-0007	PISTON-CALIPER					4
43049	43049-0008	PACKING,PISTON					4
43049A	43049-0009	PACKING,WIPER					4
43056	43056-1054	BREATHER-BRAKE					2
43057	43057-003	CAP-BREATHER					2
43080	43080-0056	CALIPER-SUB-ASSY,FR,LH					1
43080A	43080-0057	CALIPER-SUB-ASSY,FR,RH					1
43082	43082-0077	PAD-ASSY-BRAKE,FR,LH					1
43082A	43082-0078	PAD-ASSY-BRAKE,FR,RH					1
43084	43084-003	CLAMP,PAD					2
49006	49006-1054	BOOT,CALIPER					2
49006A	49006-1055	BOOT,CALIPER					2
92043	92043-1356	PIN,PAD					2
92145	92145-1260	SPRING,PAD,RH					1
92145A	92145-1354	SPRING,PAD,LH					1
92150	92150-1771	BOLT,SOCKET,8X30					8
92151	92151-1793	BOLT,FLANGED,8X19					4



This catalog covers:

'08 KSF450B8F Chassis

GRID NO.

**E-10**

This grid covers:

**Rear Brake**

F2294

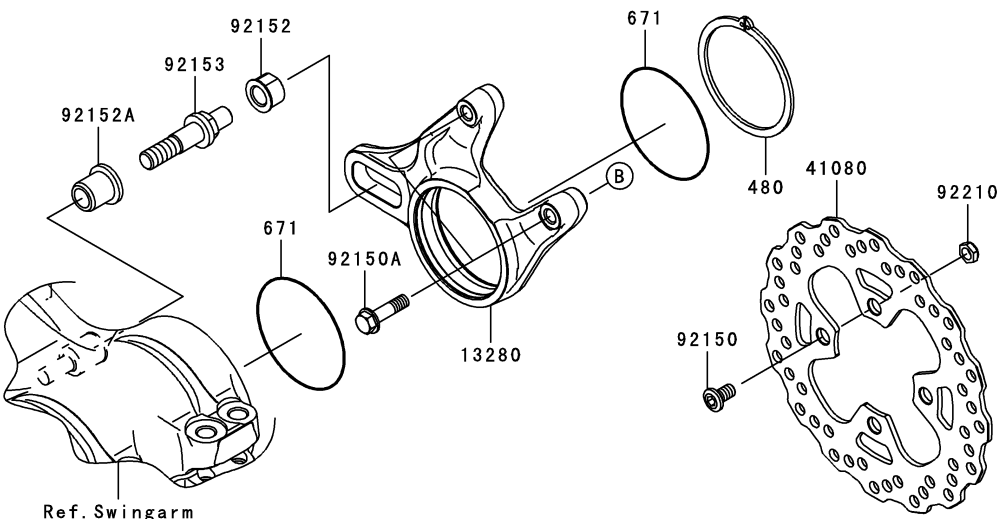
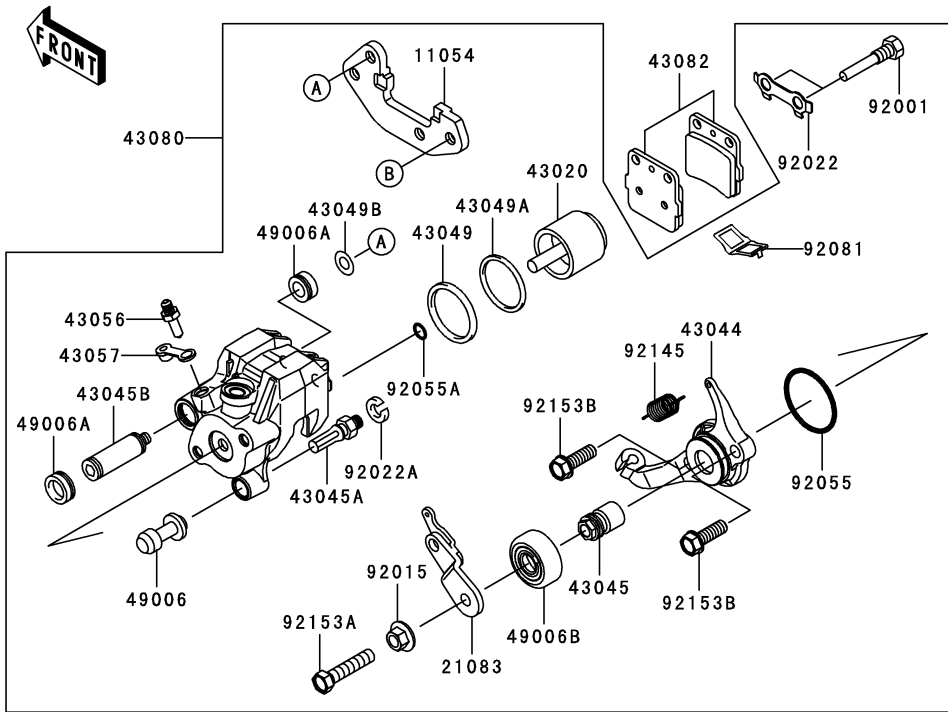

Ref. No.	Part No.	Description	Spec Code	Quantity-KSF450	
				'08	B8F
11054	11054-1865	BRACKET,REAR CALIPER		1	
13280	13280-0177	HOLDER,REAR CALIPER		1	
21083	21083-0038	ARM		1	
41080	41080-0097	DISC,RR		1	
43020	43020-1102	PISTON-COMP-BRAKE		1	
43044	43044-0023	HOLDER-COMP-CALIPER,RR		1	
43045	43045-0001	SHAFT-CALIPER		1	
43045A	43045-1010	SHAFT-CALIPER		1	
43045B	43045-1051	SHAFT-CALIPER		1	
43049	43049-1023	PACKING,PISTON SEAL		1	
43049A	43049-1024	PACKING,PISTON SEAL		1	
43049B	43049-1025	PACKING		1	
43056	43056-1055	BREATHER		1	
43057	43057-1001	CAP-BREATHER		1	
43080	43080-0058	CALIPER-SUB-ASSY,RR		1	
43082	43082-1066	PAD-ASSY-BRAKE		1	
49006	49006-1088	BOOT,CALIPER		1	
49006A	49006-1089	BOOT,CALIPER		2	
49006B	49006-1193	BOOT,CALIPER		1	
92001	92001-1723	BOLT,PAD HOLDER		2	
92015	92015-1600	NUT		1	
92022	92022-1372	WASHER,LOCK		1	
92022A	92022-1373	WASHER,WAVE		1	
92055	92055-0135	RING-O		1	
92055A	92055-1351	RING-O		1	
92081	92081-1502	SPRING,PAD		1	
92145	92145-0514	SPRING		1	
92150	92150-1811	BOLT,DISC PLATE,8X15		4	
92150A	92150-1919	BOLT		2	
92152	92152-0406	COLLAR		1	
92152A	92152-0407	COLLAR		1	
92153	92153-1491	BOLT,12MM		1	
92153A	92153-1848	BOLT		1	
92153B	92153-1849	BOLT		2	
92210	92210-1243	NUT,LOCK,8MM		4	
480	480J7500	CIRCLIP-TYPE-C,75MM		1	
671	671B2575	O RING		2	

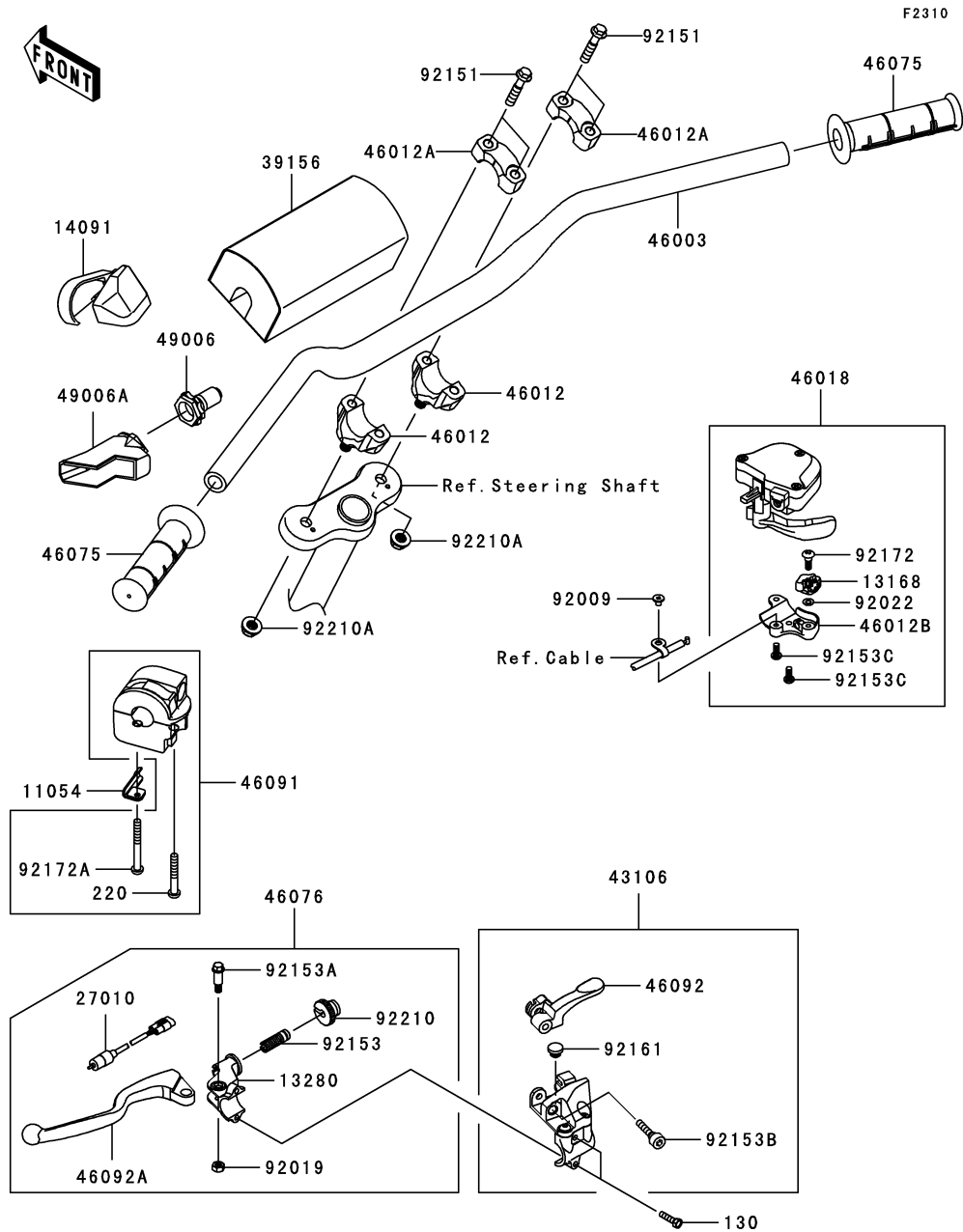

Ref. No.	Part No.	Description	Spec Code	Quantity-KSF450	
				'08	B8F
11054	11054-1824	BRACKET,SWITCH BOX STOPPER		1	
13168	13168-0152	LEVER		1	
13280	13280-0204	HOLDER,CLUTCH LEVER		1	
14091	14091-0729	COVER		1	
27010	27010-0061	SWITCH,CLUTCH		1	
39156	39156-0201	PAD,HANDLE		1	
43106	43106-0001	LEVER-ASSY-PARKING BRAKE		1	
46003	46003-0119	HANDLE		1	
46012	46012-0043	HOLDER-HANDLE,LWR		2	
46012A	46012-0044	HOLDER-HANDLE,UPP		2	
46012B	46012-0045	HOLDER-HANDLE		1	
46018	46018-0061	GRIP-ASSY-THROTTLE		1	
46075	46075-0065	GRIP		2	
46076	46076-0038	LEVER-ASSY-GRIP,CLUTCH		1	
46091	46091-0097	HOUSING-ASSY-CONTROL,LH		1	
46092	46092-0024	LEVER-GRIP		1	
46092A	46092-0025	LEVER-GRIP,CLUTCH		1	
49006	49006-0027	BOOT,CLUTCH CABLE		1	
49006A	49006-0046	BOOT		1	
92009	92009-1671	SCREW,5X6		1	
92019	92019-008	NUT,LOCK,6MM		1	
92022	92022-1380	WASHER,5.2X13X1		1	
92151	92151-1537	BOLT,FLANGED,8X35		4	
92153	92153-0773	BOLT,BOLT ADJUSTING		1	
92153A	92153-0807	BOLT		1	
92153B	92153-1718	BOLT		1	
92153C	92153-1906	BOLT		2	
92161	92161-1084	DAMPER		1	
92172	92172-0261	SCREW,5MM		1	
92172A	92172-0332	SCREW,5X38		1	
92210	92210-0167	NUT,BOLT WIRE ADJUSTING		1	
92210A	92210-1080	NUT,LOCK,FLANGED,10MM		2	
130	130CA0520	BOLT-FLANGED,5X20		2	
220	220C0535	SCREW-PAN-CROS,5X35		1	

This catalog covers:

'08 KSF450B8F Chassis

GRID NO.

**E-12**

This grid covers:

**Fuel Tank**

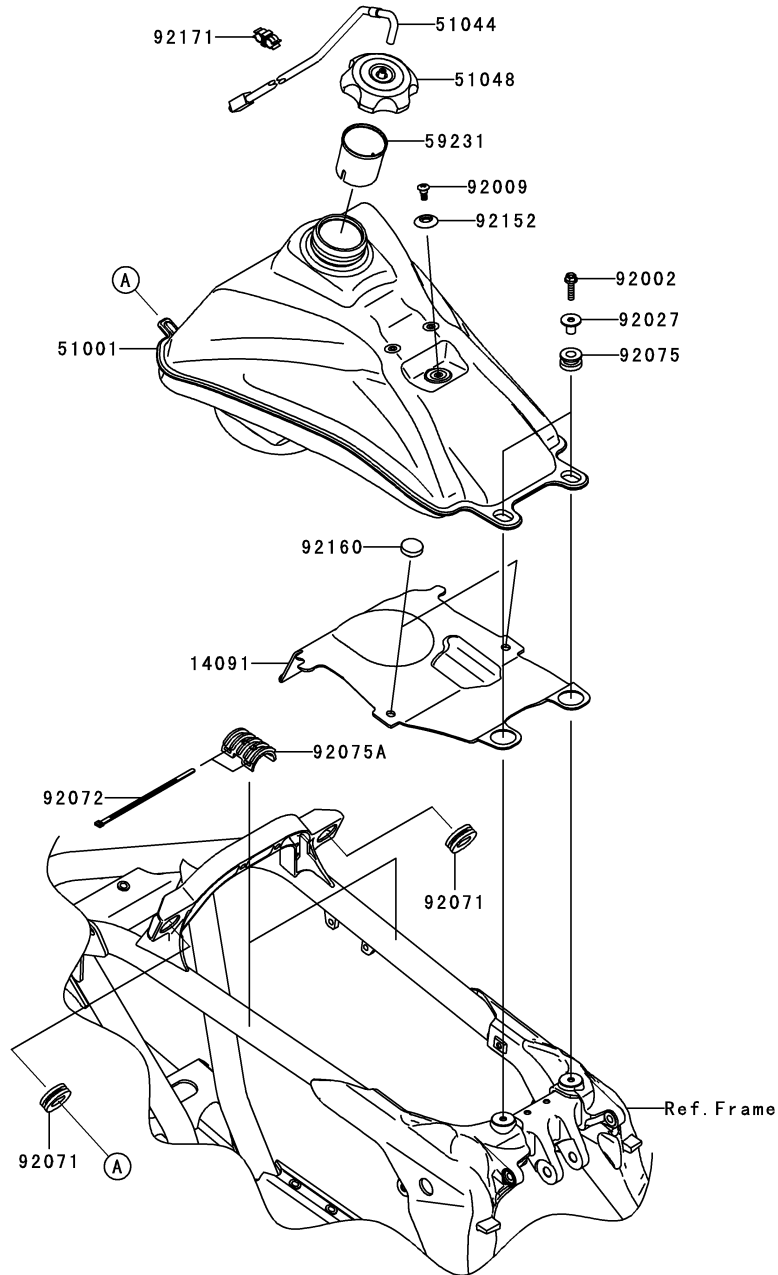

F2410

Ref. No.	Part No.	Description	Spec Code	Quantity-KSF450			
				'08			
				B8F			
14091	14091-0558	COVER,FUEL TANK,UNDER					1
51001	51001-0114	TANK-COMP-FUEL					1
51044	51044-0019	TUBE-ASSY,TANK CAP					1
51048	51048-0009	CAP-ASSY-TANK,FUEL					1
59231	59231-0029	FILLER,FUEL TANK					1
92002	92002-1339	BOLT,6X25					2
92009	92009-1971	SCREW,6MM					1
92027	92027-1847	COLLAR,L=16.1					2
92071	92071-0040	GROMMET					2
92072	92072-1239	BAND,L=188					4
92075	92075-1787	DAMPER					2
92075A	92075-1806	DAMPER,FUEL TANK					2
92152	92152-1346	COLLAR					1
92160	92160-1396	DAMPER					2
92171	92171-0129	CLAMP					1

This catalog covers:

'08 KSF450B8F Chassis

GRID NO.

**E-13**

This grid covers:

**Seat**

F2510

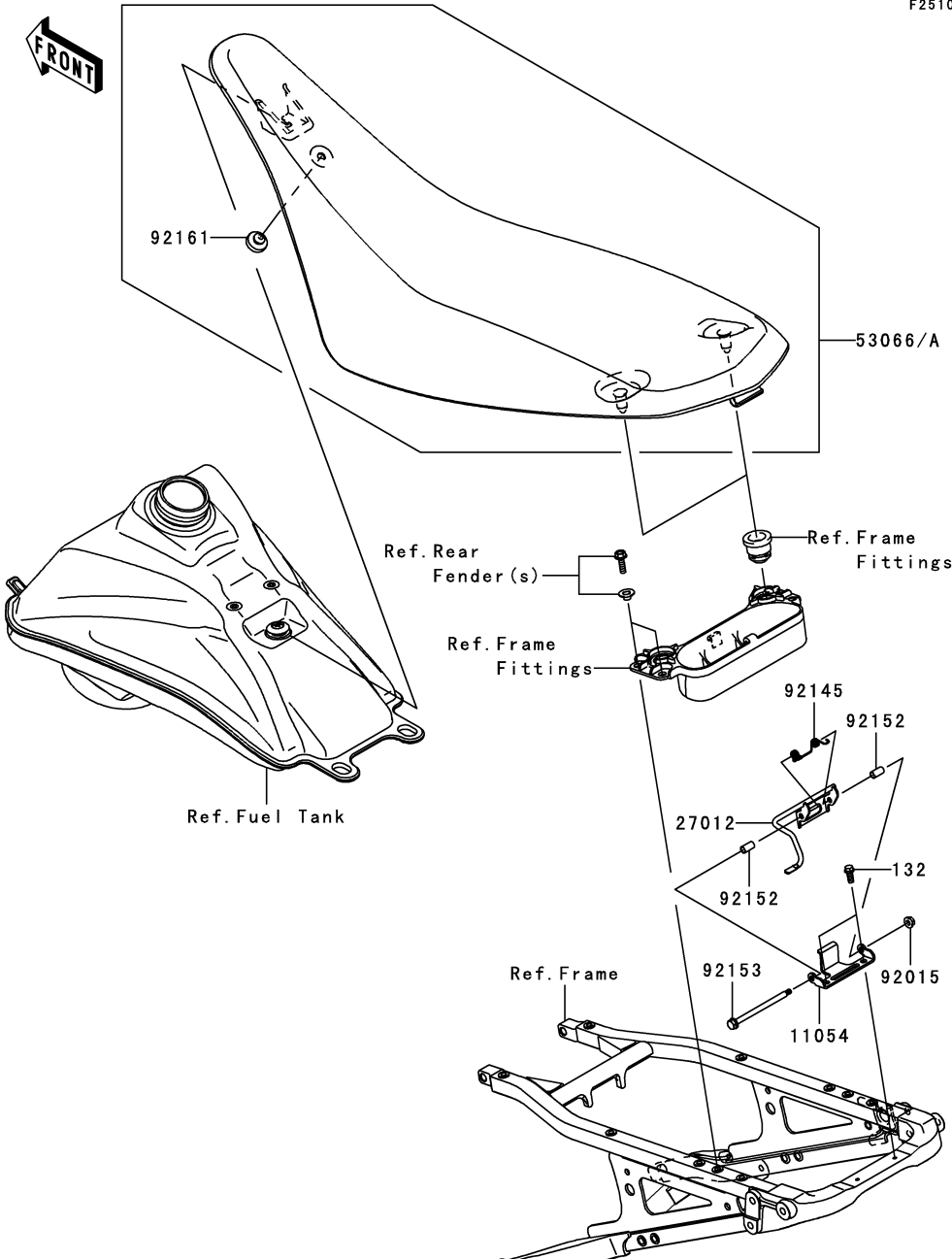

Ref. No.	Part No.	Description	Spec Code	Quantity-KSF450			
				'08			
11054	11054-1860	BRACKET, SEAT, RR					1
27012	27012-0116	HOOK, SEAT, RR					1
53066	53066-0135-13B	SEAT-ASSY, BLACK/SILVER					1
		L----- EU					1
53066A	53066-0135-336	SEAT-ASSY, GREEN/BLACK					1
92015	92015-1752	NUT, LOCK, FLANGED, 5MM					1
92145	92145-0401	SPRING					1
92152	92152-0591	COLLAR, 6.4X8X14.7					2
92153	92153-1595	BOLT, FLANGED, 5X90					1
92161	92161-0395	DAMPER, SEAT					1
132	132G0614	BOLT-FLANGED-SMALL, 6X14					2

This catalog covers:

'08 KSF450B8F Chassis

GRID NO.

**E-14**

This grid covers:

**Cables**

F2540

Ref. No.	Part No.	Description	Spec Code	Quantity-KSF450			
				'08			

49006	49006-0056	BOOT,CABLE		1
54005	54005-0021	CABLE-BRAKE		1
54010	54010-0071	CABLE,REVERSE		1
54011	54011-0054	CABLE-CLUTCH		1
54012	54012-0179	CABLE-THROTTLE		1
92072	92072-3872	BAND,L=368.3		3
132	132G0610	BOLT-FLANGED-SMALL,6X10		1

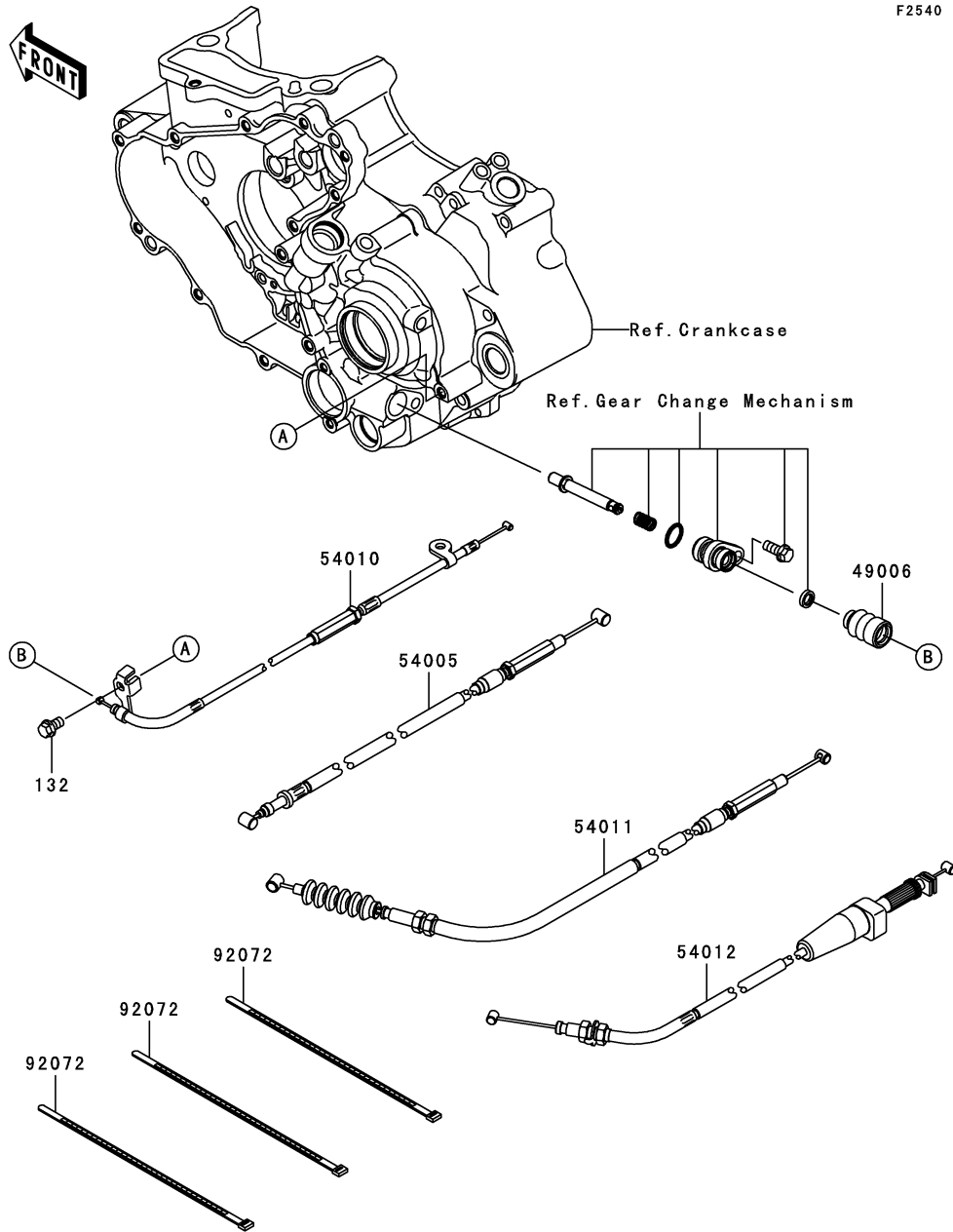



This catalog covers:

'08 KSF450B8F Chassis

GRID NO.

**F-4**

This grid covers:

**Headlight(s)**

F2710

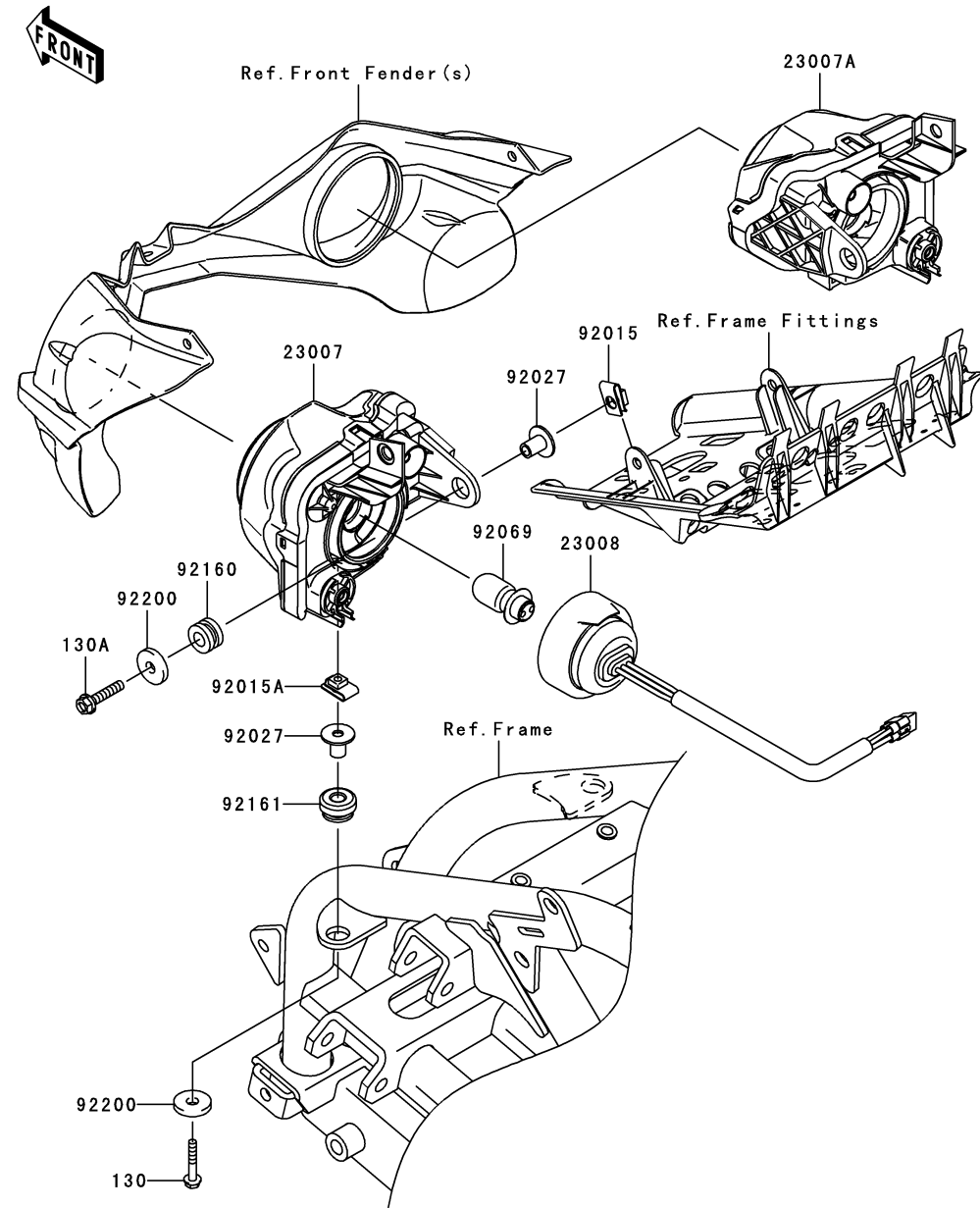

Ref. No.	Part No.	Description	Spec Code	Quantity-KSF450	
				'08	B8F
23007	23007-0094	LENS-COMP,HEAD LAMP,LH		1	
23007A	23007-0095	LENS-COMP,HEAD LAMP,RH		1	
23008	23008-0079	SOCKET-ASSY,HEAD LAMP		2	
92015	92015-1602	NUT,6MM		2	
92015A	92015-1710	NUT,5MM		2	
92027	92027-1847	COLLAR,L=16.1		4	
92069	92069-1080	BULB,12V 30/30W		2	
92160	92160-1167	DAMPER		2	
92161	92161-0483	DAMPER		2	
92200	92200-0359	WASHER,6.5X20X3.2		4	
130	130G0530	BOLT-FLANGED,5X30		2	
130A	130G0630	BOLT-FLANGED,6X30		2	

This catalog covers:

'08 KSF450B8F Chassis

GRID NO.

**F-5**

This grid covers:

**Taillight(s)**

F2720

Ref. No.	Part No.	Description	Spec Code	Quantity-KSF450			
				'08			
23025	23025-0046	LAMP-TAIL		1			
92015	92015-1757	NUT,WELL,5MM		3			
92022	92022-3041	WASHER,5X16X1.5		4			
92027	92027-1313	COLLAR,5X7X9.3		3			
92161	92161-1188	DAMPER		3			
92200	92200-0381	WASHER,5.1X16X6		2			
130	130G0525	BOLT-FLANGED,5X25		1			
130A	130G0530	BOLT-FLANGED,5X30		2			

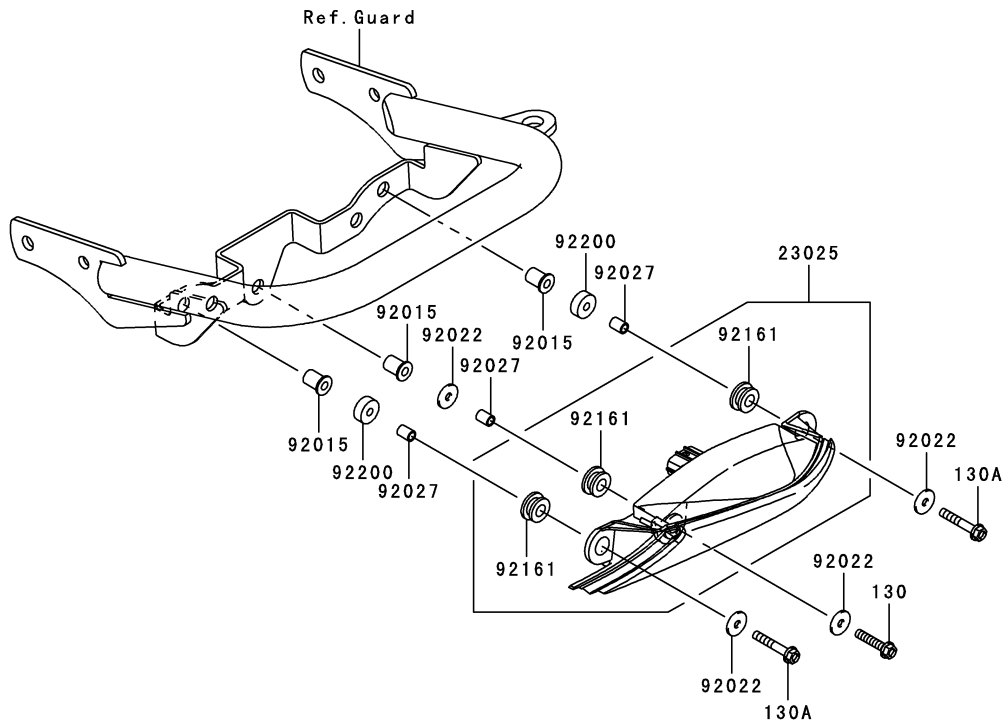



This catalog covers:

'08 KSF450B8F Chassis

GRID NO.

**F-7**

This grid covers:

**Ignition Switch**

F2770

Ref. No.	Part No.	Description	Spec Code	Quantity-KSF450			
				'08			
11054	11054-0271	BRACKET,BRAKE SWITCH					1
23016	23016-1192	LAMP-ASSY					1
23026	23026-1105	LENS,PILOT,RED					3
23026A	23026-1107	LENS,PILOT,GREEN					1
27005	27005-1229	SWITCH-ASSY-IGNITION					1
27010	27010-1494	SWITCH,BRAKE					1
27011	27011-014	SPRING,SWITCH					1
92069	92069-1007	BULB,12V 3.4W,T10					4
92151	92151-1647	BOLT,6X14					1
92210	92210-1109	NUT,IGNITION SWITCH					1

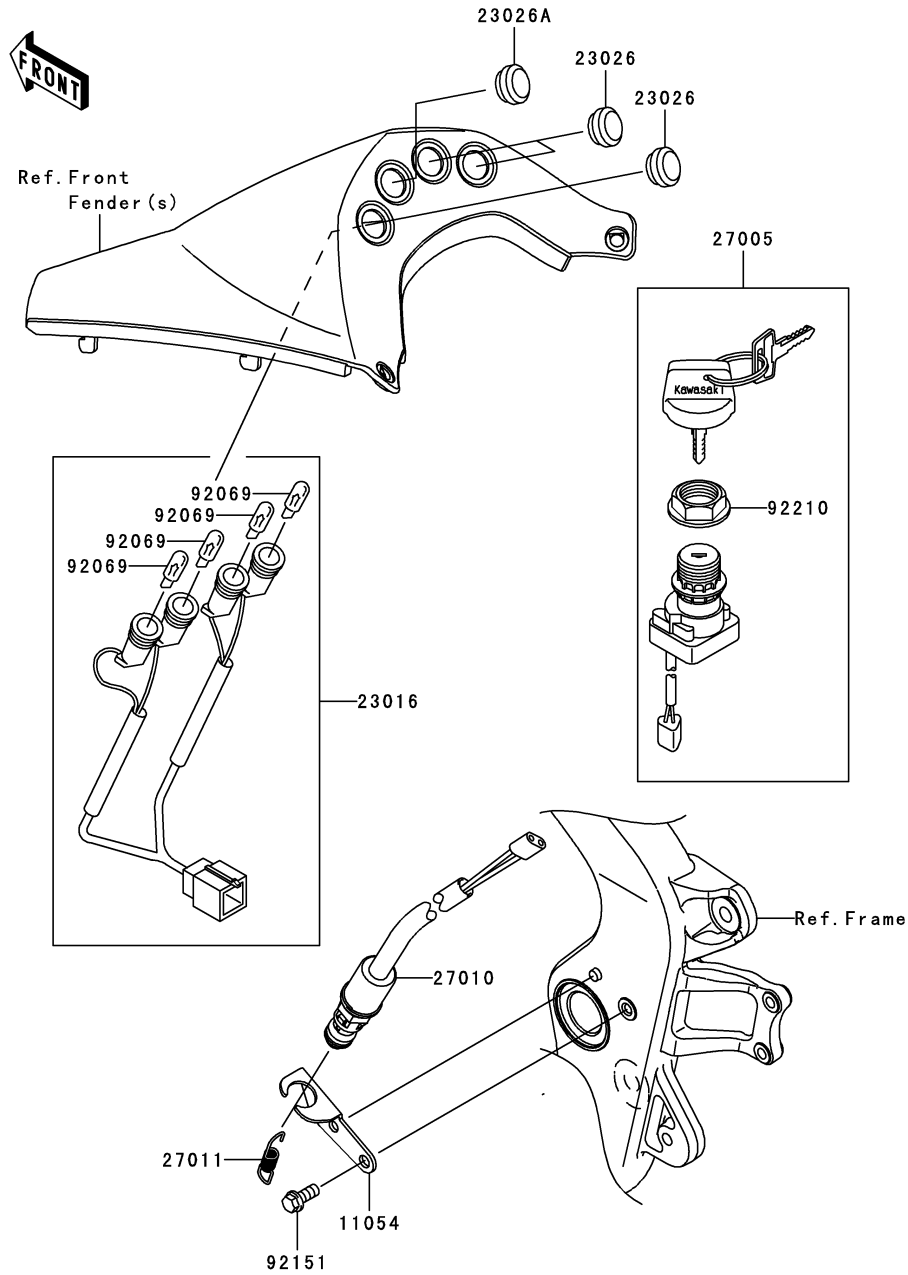

This catalog covers:

'08 KSF450B8F Chassis

GRID NO.

**F-8**

This grid covers:

**Owner's Tools**

F2810

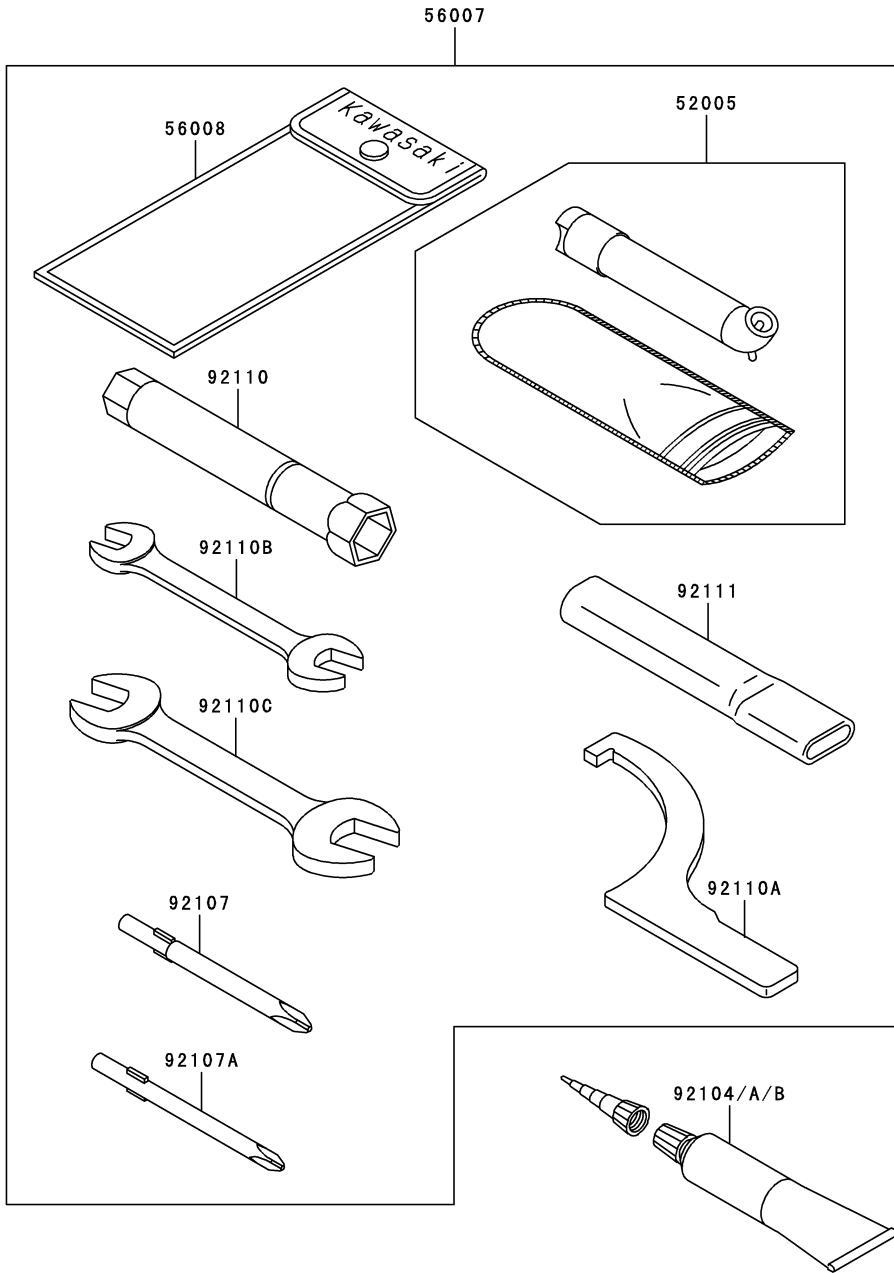

Ref. No.	Part No.	Description	Spec Code	Quantity-KSF450			
				'08			
				B8F			
52005	52005-1082	GAUGE,AIR					1
56007	56007-0038	TOOL-KIT					1
56008	56008-1007	BAG,TOOL					1
92104	92104-0004	GASKET-LIQUID,TB1211F					1
92104A	92104-1063	GASKET-LIQUID,TB1216,GRAY					1
92104B	92104-1064	GASKET-LIQUID,BLACK TB1216B					1
92107	92107-005	TOOL-DRIVER,#3PHILLIPS					1
92107A	92107-1053	TOOL-DRIVER,#2PHILLIPS					1
92110	92110-0002	TOOL-WRENCH,BOX,16MM					1
92110A	92110-0017	TOOL-WRENCH,HOOK					1
92110B	92110-1152	TOOL-WRENCH,OPEN END,10X12					1
92110C	92110-1153	TOOL-WRENCH,OPEN END,14X17					1
92111	92111-1051	TOOL-BAR,BOX END WRENCH					1

This catalog covers:

'08 KSF450B8F Chassis

GRID NO.

**F-9**

This grid covers:

**Labels**

F2860

Ref. No.	Part No.	Description	Spec Code	Quantity-KSF450		
				'08	B8F	
56030	56030-0018	LABEL,IGNITION SWITCH			1	
56030A	56030-0135	LABEL			1	
56030B	56030-0161	LABEL,GASOLINE			1	
56030C	56030-0162	LABEL,GASOLINE(FRENCH)			1	
	L-----		EU		1	
56033	56033-0064	LABEL-MANUAL,AIR CLEANER			1	
56040	56040-1157	LABEL,UNLEADED PETROL ONLY			1	
	L-----		AS		1	
56040A	56040-1289	LABEL-WARNING,CHAIN SLACK			1	
56040B	56040-1297	LABEL-WARNING,CHAIN SLACK			1	
	L-----		EU		1	
56070	56070-0018	LABEL-WARNING,NO PASSENGER			1	
	L-----		EU		1	
56070A	56070-1108	LABEL-WARNING,FUEL UNLEADED			1	
	L-----		EU		1	
56070B	56070-1110	LABEL-WARNING,AGE RECOMMEND			1	
	L-----		EU		1	
56070C	56070-1141	LABEL-WARNING,NO PASSENGER			1	
56070D	56070-1286	LABEL-WARNING,GENERAL			1	
	L-----		AS		1	
56071	56071-0013	LABEL-WARNING,TIRE INFO			1	
	L-----		AS		1	
56071A	56071-0026	LABEL-WARNING,TIRE INFO			1	
	L-----		EU		1	
56071B	56071-0036	LABEL-WARNING,GENERAL			1	
	L-----		EU		1	
56071C	56071-0037	LABEL-WARNING,OIL CHECK			1	
56071D	56071-0038	LABEL-WARNING,OIL CHECK			1	
	L-----		EU		1	
92039	92039-3763	RIVET,3.2X8			6	
92200	92200-1251	WASHER,3.5X8X1			6	

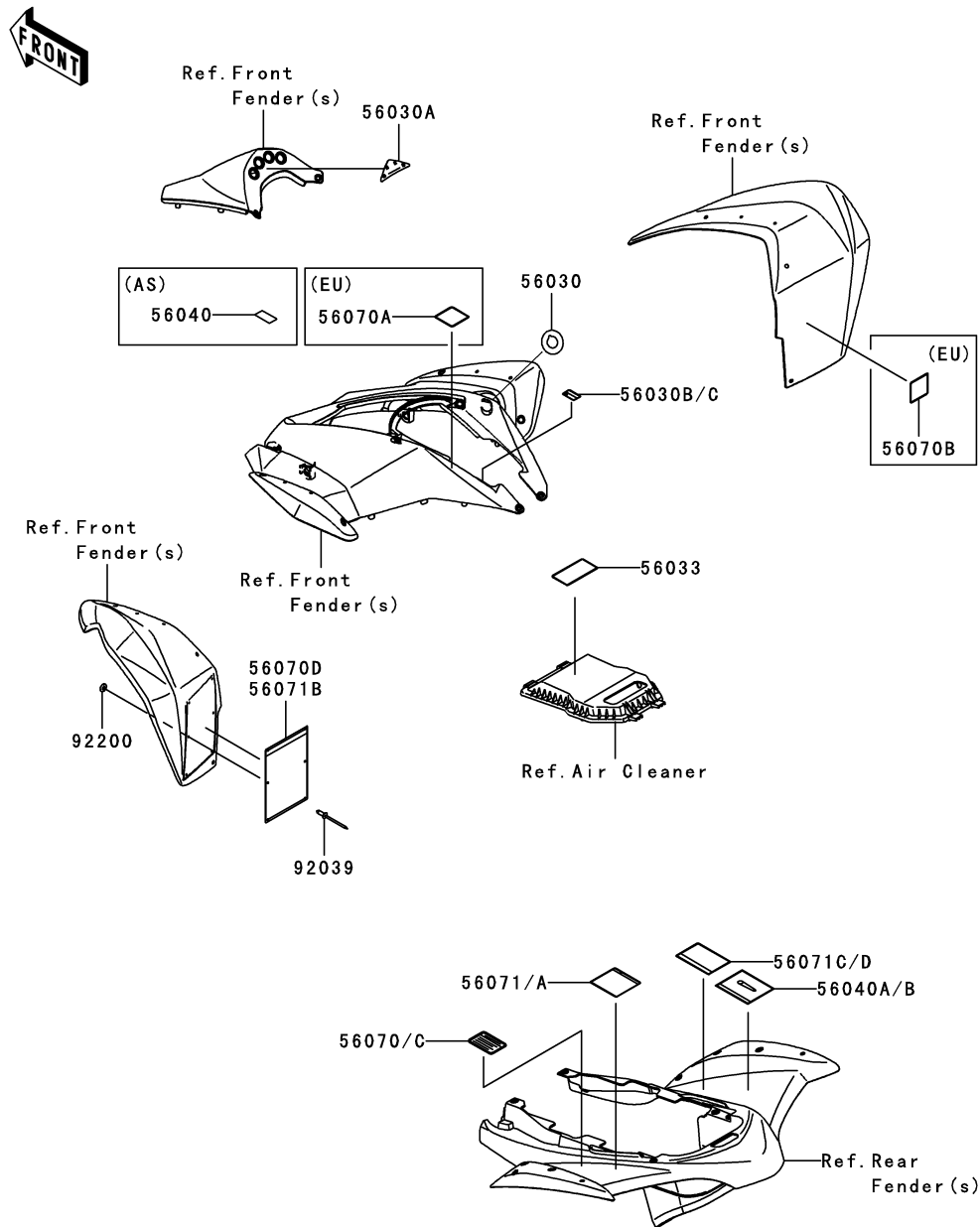

This catalog covers:

'08 KSF450B8F Chassis

GRID NO.

**F-10**

This grid covers:

**Decals(White)(EU)**

F2861

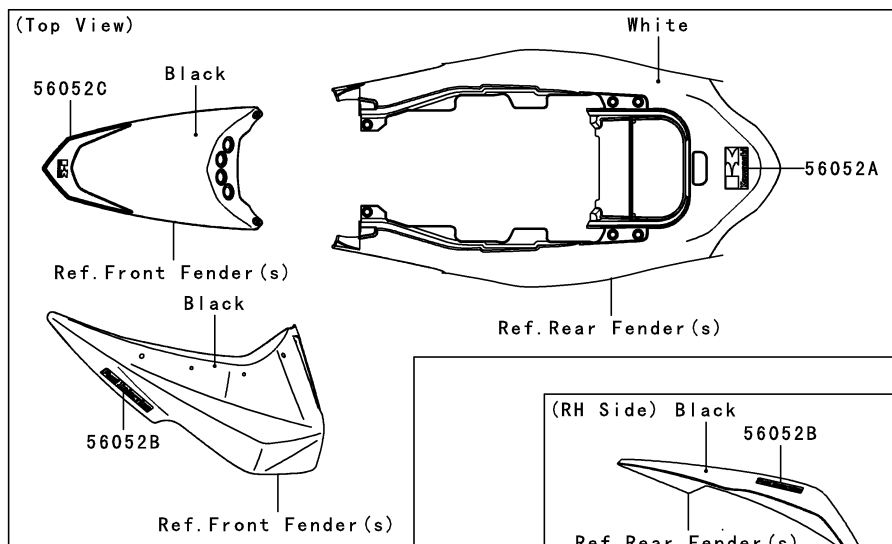

Ref. No.	Part No.	Description	Spec Code	Quantity-KSF450			
				'08			
56052	56052-1987	MARK,FR FENDER,KAWASAKI					
	L-----						
56052A	56052-1989	MARK,RR FENDER,KAWASAKI	EU	2			
	L-----						
56052B	56052-1990	MARK,FUEL INJECTION					
	L-----						
56052C	56052-1992	MARK,MAINTENANCE COVER	EU	2			
	L-----						
56052D	56052-1993	MARK,FR FENDER,KFX450R	EU	1			
	L-----						
56067	56067-1927	PATTERN,SIDE COVER,LH					
	L-----						
56067A	56067-1928	PATTERN,SIDE COVER,RH	EU	1			
	L-----						
56067B	56067-1929	PATTERN,RR FENDER,OUTER,LH	EU	1			
	L-----						
56067C	56067-1930	PATTERN,RR FENDER,OUTER,RH	EU	1			
	L-----						

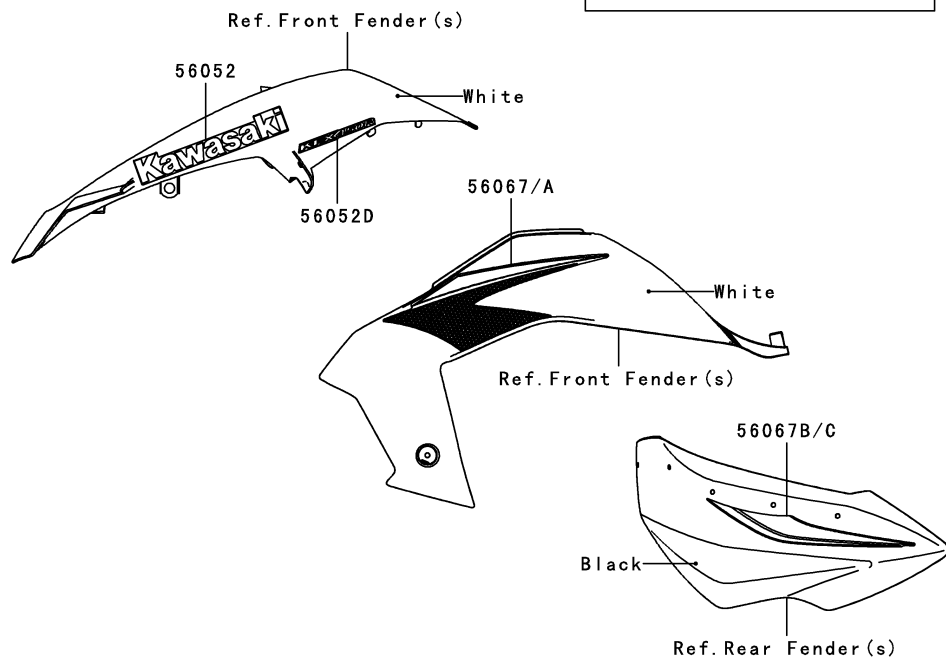

This catalog covers:

'08 KSF450B8F Chassis

GRID NO.

**F-11**

This grid covers:

**Decals(Green)**

F2861A

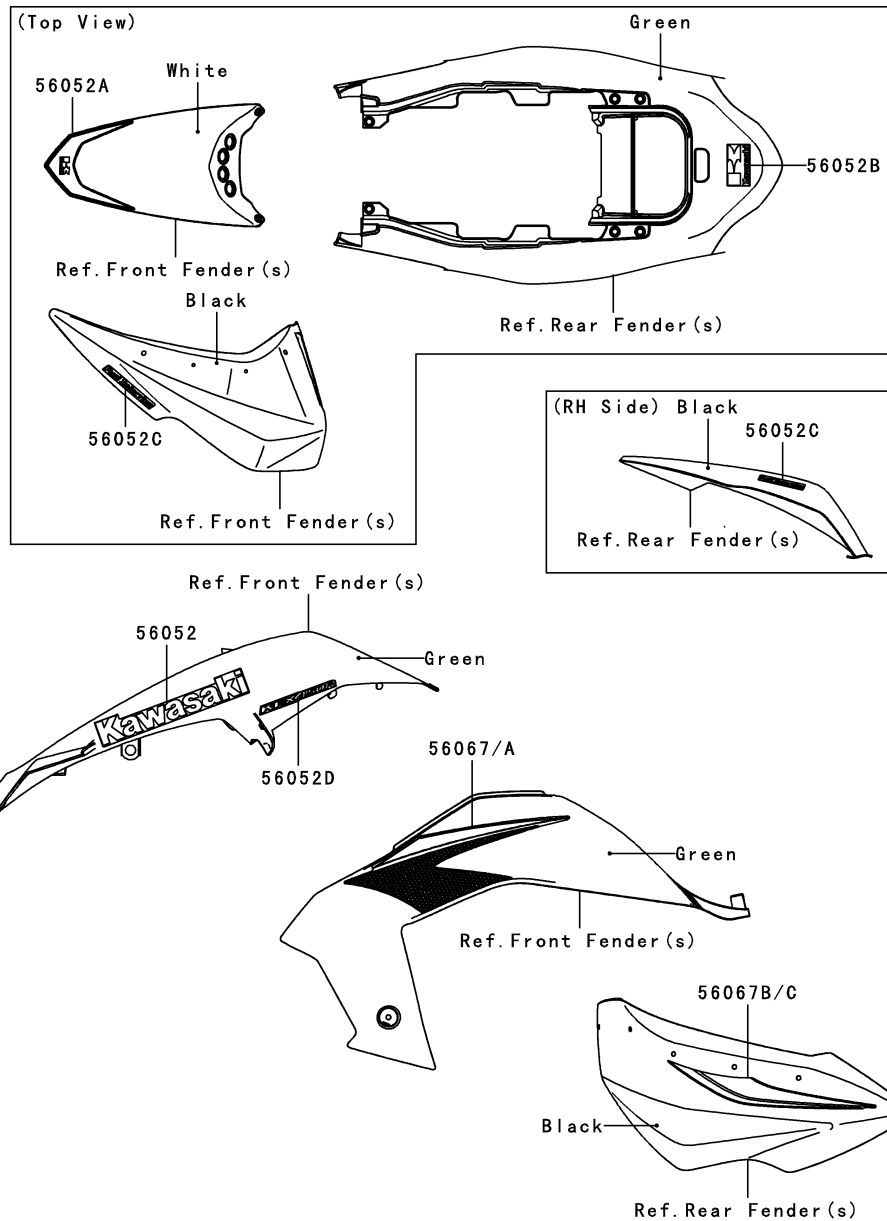

Ref. No.	Part No.	Description	Spec Code	Quantity-KSF450			
				'08			
56052	56052-1987	MARK,FR FENDER,KAWASAKI					2
56052A	56052-1988	MARK,MAINTENANCE COVER					1
56052B	56052-1989	MARK,RR FENDER,KAWASAKI					1
56052C	56052-1990	MARK,FUEL INJECTION					2
56052D	56052-1991	MARK,FR FENDER,KFX450R					2
56067	56067-1923	PATTERN,SIDE COVER,LH					1
56067A	56067-1924	PATTERN,SIDE COVER,RH					1
56067B	56067-1925	PATTERN,RR FENDER,OUTER,LH					1
56067C	56067-1926	PATTERN,RR FENDER,OUTER,RH					1

This catalog covers:

'08 KSF450B8F Chassis

GRID NO.

**F-12**

This grid covers:

**Manual(EU)**

F2920

Owner's Manual  
(Local Procurement)

99923  
99947  
99972  
99984  
99992

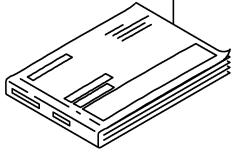

Ref. No.	Language
(99923)	German
(99947)	French
(99972)	Spanish
(99984)	Dutch
(99992)	Italian

Service Manual

99953  
99954  
99956

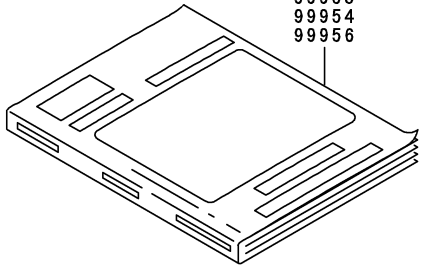

Ref. No.	Language
(99953)	German
(99954)	French
(99956)	Spanish

A&P Manual

99946  
99950  
99952

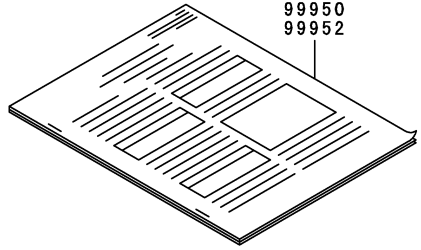

Ref. No.	Language
(99946)	German
(99950)	French
(99952)	Spanish

Ref. No.	Part No.	Description	Spec Code	Quantity-KSF450			
				'08			
				B8F			
99923	99923-1620	OWNER'S MANUAL,GERMAN					
		L-----	EU	1			
99946	99946-1044-01	A&P MANUAL,GERMAN					
		L-----	EU	1			
99947	99947-1381	OWNER'S MANUAL,FRENCH					
		L-----	EU	1			
99950	99950-1051-01	A&P MANUAL,FRENCH					
		L-----	EU	1			
99952	99952-1019-01	A&P MANUAL,SPANISH					
		L-----	EU	1			
99953	99953-1041-01	SERVICE MANUAL,GERMAN					
		L-----	EU	1			
99954	99954-1052-01	SERVICE MANUAL,FRENCH					
		L-----	EU	1			
99956	99956-1017-01	SERVICE MANUAL,SPANISH					
		L-----	EU	1			
99972	99972-1116	OWNER'S MANUAL,SPANISH					
		L-----	EU	1			
99984	99984-1086	OWNER'S MANUAL,DUTCH					
		L-----	EU	1			
99992	99992-1049	OWNER'S MANUAL,ITALIAN					
		L-----	EU	1			

This catalog covers:  
**'08 KSF450B8F**

GRID NO. This grid covers:  
**L-13 Numerical Parts Index**

Part No.	Grid No.	Part No.	Grid No.	Part No.	Grid No.	Part No.	Grid No.	Part No.	Grid No.	Part No.	Grid No.
11004-0073	B-3	12053-0081	C-4	13107-0159	D-9	13280-0231	B-6	14091-0729	E-11	26006-0009	F-6
11005-0080	B-5	12053-0083	F-3	13116-0019	B-11	13280-0261	C-12	14091-0744	D-5	26006-1006	C-12
11008-0098	B-3	12053-0100	D-8	13116-0024	B-14	132BC0670	C-4	14091-0793-266	D-12	26011-0098	F-6
11009-1145	C-14	12053-0110	B-9	13127-0039	B-12	132G0510	D-4	14091-0793-290	D-12	26011-0103	C-12
11010-0135	B-6	120CA0840	D-3	13140-0034	B-13	132G0610	E-14	14091-0796	B-4	26011-0119	F-6
11011-0075	B-6	120R0610	B-7	13140-0035	B-13	132G0610	E-9	16007-0022	B-8	26011-0149	F-6
11012-1084	C-14	120S0510	C-12	13141-0037	B-13	132G0612	F-6	16007-0026	B-8	26012-0084	F-6
11013-0017	B-6	13001-0079	B-5	13144-0042	B-12	132G0614	E-13	16016-0022	C-5	26031-0404	F-6
11054-0271	F-7	13002-0014	B-5	13145-0022	B-13	132G0616	C-8	16065-0031	B-3	27002-1088	F-6
11054-0279	D-5	13008-0022	B-5	13151-0029	B-13	132G0618	C-4	16073-0053	C-12	27005-1229	F-7
11054-0280	D-5	13031-0068	B-10	13161-0055	B-14	132G0618	C-8	16073-3707	C-5	27010-0025	E-7
11054-0291	E-7	13032-0054	B-10	13165-0017	B-14	132G0630	C-8	16085-0092	C-12	27010-0030	C-12
11054-1271	E-5	13034-0006	B-10	13168-0129	B-14	132G0630	D-6	16085-0093	C-12	27010-0061	E-11
11054-1710	D-5	13035-0013	B-10	13168-0152	E-11	132J0612	C-8	16126-4001	D-14	27010-1494	F-7
11054-1805	D-5	13037-0082	B-10	13183-1722	B-11	132J0612	E-7	16130-1058	C-8	27011-014	F-7
11054-1819	D-5	13037-0083	B-10	13187-0007	B-11	132J0620	E-7	16142-0032	C-8	27012-0116	E-13
11054-1824	E-11	13041-0017	B-10	13194-0008	C-12	132J0625	E-7	16142-0033	C-8	31064-0090	C-5
11054-1838	C-7	13041-0021	B-10	13234-0029	C-8	132L0608	C-13	16142-0034	C-13	311G0600	B-14
11054-1860	E-13	13042-0005	B-9	13236-0105	E-5	132L0608	C-3	16154-0069	C-8	311G0600	C-11
11054-1865	E-10	13078-0012	B-14	13236-0118	E-7	132L0612	B-3	16163-0083	C-5	315C1200	D-4
11054-1881	D-5	13087-0015	B-11	13236-0129	B-14	132Y0612	C-7	172G0612	B-14	32085-1437	E-8
11055-0070	D-5	13088-0010	B-11	13262-0352	B-12	132Y0614	B-11	18077-0001	B-7	32085-1517	E-8
11055-0071	D-5	13088-0029	B-11	13262-0355	B-12	132Y0614	B-14	18088-0261	B-7	32097-0024	D-7
11060-1300	B-3	13088-0035	B-11	13262-0356	B-12	132Y0625	C-12	18091-0446	B-7	32097-0026	D-7
11061-0079	B-4	13089-1005	B-11	13262-0357	B-12	132Y0630	C-4	18110-0051	B-7	320H1000	D-4
11061-0082	B-7	13089-1010	B-11	13262-0358	B-12	132Y0650	C-3	21003-0067	C-10	32153-1189	C-8
11061-0185	B-4	13089-1095	B-11	13262-0362	B-12	132Y0660	C-3	21007-0107	C-10	32160-0170	D-3
11061-0226	B-7	13095-0074	B-11	13262-0476	B-12	132Y0680	C-3	21039-0005	C-12	32180-0001	D-3
11061-0234	B-5	13097-0061	B-10	13262-0503	B-12	13307-0002	B-12	21040-0003	C-12	32190-0281	D-5
11061-0235	C-4	130CA0520	E-11	13262-0504	B-12	14001-0079	C-3	21066-0017	C-10	32190-0296	D-5
11061-0236	C-4	130G0514	C-10	13262-0505	B-12	14013-0001	B-9	21083-0038	E-10	32190-0297	D-5
11061-0237	C-13	130G0516	D-5	13262-0572	B-12	14026-0035	C-4	21121-0032	C-11	32190-0298	D-5
11061-0259	C-4	130G0525	F-5	13271-0334	C-3	14031-0061	C-4	21160-0011	C-11	32190-0299	D-5
11061-0260	B-9	130G0530	F-4	13271-0582	C-3	14032-0083	C-4	21163-0033	C-12	321H1000	D-4
11061-0298	B-7	130G0530	F-5	13271-0675	B-3	14032-0101	C-4	21175-0099	C-7	33001-0105	D-8
11065-0107	C-9	130G0616	D-6	13271-0760	C-10	14037-0055	C-14	21176-0009	C-7	33032-0019	D-8
11065-0155	C-4	130G0620	D-12	13271-0867	C-3	14044-0027	B-11	21176-0048	C-7	34028-0080	D-11
11065-0186	B-6	130G0630	F-4	13271-0943	C-3	14067-006	C-3	21176-0058	C-7	34028-0081	D-11
115S0855	D-4	130G0814	F-3	13272-0073	B-14	14073-0115	B-6	21176-0066	C-7	35004-0067-266	D-12
12004-0026	B-8	130J0620	C-7	13272-0080	D-5	14073-0154	B-6	220B0608	D-8	35004-0067-290	D-12
12005-0036	B-8	130J0625	C-10	13272-0081	D-9	14075-0005	B-14	220C0535	E-11	35004-0068-839	D-12
12009-0008	B-8	130J0625	C-4	13280-0067	B-11	14090-1331	F-6	224C0614	C-14	35004-0069-839	D-12
12011-1003	B-8	130J0635	C-4	13280-0109	C-12	14090-1611	F-6	225B0520	B-13	35023-0081-839	D-13
12032-0004	B-8	130J0816	D-11	13280-0175	E-4	14091-0554-266	D-12	23007-0094	F-4	35023-0082-839	D-13
12046-0043	B-9	130P0625	D-12	13280-0176	E-4	14091-0554-839	D-12	23007-0095	F-4	35023-0113-266	D-13
12048-0050	B-9	130P0630	D-7	13280-0177	E-10	14091-0555-266	D-12	23008-0079	F-4	35023-0113-290	D-13
12053-0051	B-9	13102-0030	B-11	13280-0188	B-12	14091-0555-290	D-12	23016-1192	F-7	35063-0290	D-13
12053-0077	D-5	13107-0134	C-8	13280-0204	E-11	14091-0557-6Z	D-12	23025-0046	F-5	35063-0291	D-13
12053-0078	B-9	13107-0135	C-13	13280-0208	B-6	14091-0558	E-12	23026-1105	F-7	35063-0398	D-12
12053-0079	B-9	13107-0138	C-8	13280-0230	B-6	14091-0728	C-5	23026-1107	F-7	35063-0399	D-12

This catalog covers:  
**'08 KSF450B8F**

GRID NO.

**L-14**

This grid covers:

**Numerical Parts Index**

Part No.	Grid No.	Part No.	Grid No.	Part No.	Grid No.	Part No.	Grid No.	Part No.	Grid No.	Part No.	Grid No.
35063-0426	D-12	43022-1010	E-7	480J2000	B-12	54012-0179	E-14	56070-1141	F-9	92009-1621	D-11
35063-0442	F-3	43026-0010	E-7	480J2200	B-12	55020-0221-6Z	D-11	56070-1286	F-9	92009-1663	D-11
35063-0457	D-12	43026-1086	E-9	480J3200	B-10	55020-0222-6Z	D-11	56071-0013	F-9	92009-1671	E-11
39007-0070-16H	D-9	43028-1061	E-7	480J7500	E-10	55020-0223	D-11	56071-0026	F-9	92009-1795	E-7
39007-0071-16H	D-9	43028-1092	E-9	481J2000	C-4	55020-0226	D-11	56071-0036	F-9	92009-1971	E-12
39007-0074	D-10	43034-1110	E-7	481J2100	C-3	55020-0227	F-3	56071-0037	F-9	92009-1984	C-7
39007-0091-16H	D-9	43044-0010	E-8	481J2400	D-9	55020-0327	D-11	56071-0038	F-9	92009-3830	D-5
39007-0092-16H	D-9	43044-0011	E-8	481J4000	C-3	55020-0328	D-11	59051-0044	C-8	92009-3830	F-3
39045-0026	B-6	43044-0023	E-10	481J6500	E-4	55020-0393	F-3	59051-0070	B-10	92009-3848	E-5
39061-0125	C-14	43045-0001	E-10	482J5000	B-9	55020-0394	F-3	59051-0071	B-10	92015-1156	B-10
39062-0146	C-14	43045-1010	E-10	49002-0007	B-3	550D2015	E-9	59051-0073	C-8	92015-1156	C-10
39062-0201	C-14	43045-1051	E-10	49006-0027	E-11	550D2518	D-4	59051-0075	B-10	92015-1189	D-5
39062-0202	C-14	43048-0007	E-8	49006-0046	E-11	550D2520	D-4	59231-0029	E-12	92015-1233	C-14
39062-0215	C-14	43049-0008	E-8	49006-0049	B-6	550D2520	D-9	59256-0003	C-13	92015-1339	D-5
39076-0009	C-12	43049-0009	E-8	49006-0056	E-14	550D3025	D-9	59266-0013	D-9	92015-1401	D-10
39111-0047	D-10	43049-1023	E-10	49006-1054	E-8	550D3030	E-3	59266-0014	D-9	92015-1402	B-7
39111-0052	D-4	43049-1024	E-10	49006-1055	E-8	550D4025	E-4	59266-0015	D-9	92015-1432	D-3
39112-0011	D-4	43049-1025	E-10	49006-1088	E-10	551A0425	B-12	59266-0026	D-4	92015-1432	E-4
39112-0012	D-4	43056-1054	E-8	49006-1089	E-10	56007-0038	F-8	59502-0029	C-14	92015-1432	F-3
39114-0012-21	D-4	43056-1055	E-10	49006-1193	E-10	56008-1007	F-8	601A6204	C-3	92015-1433	D-10
39115-0014	B-12	43057-003	E-8	49016-1044	E-7	56030-0018	F-9	610A0408	B-13	92015-1476	C-12
39156-0201	E-11	43057-1001	E-10	49030-0029	E-4	56030-0135	F-9	610A0408	C-13	92015-1487	C-14
39186-0076	D-9	43058-0016	E-4	49030-1142	E-3	56030-0161	F-9	610A0408	C-4	92015-1528	E-7
39186-0077	D-9	43078-0043	C-14	49033-0010	C-5	56030-0162	F-9	610A0408	C-8	92015-1532	D-4
39193-0027	B-3	43080-0056	E-8	49040-0020	C-6	56033-0064	F-9	670B2012	B-14	92015-1600	E-10
39193-0038	C-8	43080-0057	E-8	49047-0024	B-13	56033-0200	C-4	670B2012	E-5	92015-1602	C-10
41009-0120	D-14	43080-0058	E-10	49047-0025	B-13	56040-1157	F-9	670D1505	C-8	92015-1602	C-7
41009-0161	D-14	43082-0077	E-8	49065-0019	C-9	56040-1289	F-9	670D1507	C-8	92015-1602	D-12
41025-0070	D-14	43082-0078	E-8	49078-0018	B-8	56040-1297	F-9	670D1508	C-3	92015-1602	D-5
41025-0071	D-14	43082-1066	E-10	49078-0043	B-8	56052-1987	F-10	670D2010	B-9	92015-1602	F-4
41046-0015	E-4	43084-003	E-8	49085-0005	C-14	56052-1987	F-11	670E5075	C-6	92015-1603	D-11
41068-0052	E-4	43095-0326	E-7	49091-0001	E-7	56052-1988	F-11	671B2575	E-10	92015-1603	F-3
41080-0097	E-10	43095-0344	E-7	49091-0001	E-9	56052-1989	F-10	671B2585	E-4	92015-1692	C-14
41080-1534	E-8	43095-0345	E-9	49107-0078	B-7	56052-1989	F-11	92001-1723	E-10	92015-1710	F-4
411B0500	D-6	43106-0001	E-11	49107-0111	B-7	56052-1990	F-10	92002-1323	E-7	92015-1725	B-11
411B0600	D-6	45014-0184-EH	E-6	49118-0095	B-9	56052-1990	F-11	92002-1327	B-4	92015-1752	D-13
42036-0036	D-8	45014-0185-EH	E-6	49118-0105	B-9	56052-1991	F-11	92002-1339	D-12	92015-1752	E-13
42036-0037	D-9	46003-0119	E-11	51001-0114	E-12	56052-1992	F-10	92002-1339	E-12	92015-1757	B-6
42036-0038	D-10	46012-0043	E-11	51044-0019	E-12	56052-1993	F-10	92002-1347	D-10	92015-1757	D-12
42036-0039	D-10	46012-0044	E-11	51044-0031	C-6	56067-1923	F-11	92002-1348	D-5	92015-1757	F-5
42036-1258	E-6	46012-0045	E-11	51048-0009	E-12	56067-1924	F-11	92002-1349	E-4	92015-1759	D-3
42036-1351	D-10	46018-0061	E-11	510A3200	C-10	56067-1925	F-11	92002-1418	E-9	92015-1765	E-3
42036-1376	D-9	46075-0065	E-11	52005-0019	C-4	56067-1926	F-11	92002-1418	F-3	92015-1792	D-12
42041-0044	E-4	46076-0038	E-11	52005-1082	F-8	56067-1927	F-10	92002-1576	D-5	92015-1792	D-3
43010-0006	E-9	46091-0097	E-11	52010-1053	C-9	56067-1928	F-10	92002-2274	B-6	92015-1794	D-3
43015-0070	E-7	46092-0024	E-11	53066-0135-13B	E-13	56067-1929	F-10	92004-0025	B-3	92015-1963	B-12
43015-0107	E-9	46092-0025	E-11	53066-0135-336	E-13	56067-1930	F-10	92005-0018	B-3	92019-008	E-11
43020-1094	E-9	461K0500	C-12	54005-0021	E-14	56070-0018	F-9	92009-1256	D-11	92022-1028	E-9
43020-1098	E-7	461S0600	B-7	54010-0071	E-14	56070-1108	F-9	92009-1465	C-14	92022-1065	D-9
43020-1102	E-10	480J1000	C-13	54011-0054	E-14	56070-1110	F-9	92009-1549	C-5	92022-107	D-10

This catalog covers:  
**'08 KSF450B8F**

GRID NO. L-15 This grid covers:  
**Numerical Parts Index**

Part No.	Grid No.	Part No.	Grid No.	Part No.	Grid No.	Part No.	Grid No.	Part No.	Grid No.	Part No.	Grid No.
92022-1346	C-14	92027-1354	F-3	92046-1190	B-11	92066-0092	C-4	92143-1087	F-3	92152-0286	D-11
92022-1356	B-10	92027-1651	D-12	92046-1272	E-6	92066-0106	C-4	92143-1156	D-8	92152-0401	D-13
92022-1372	E-10	92027-1651	D-5	92046-1301	D-10	92066-1174	C-3	92143-1353	C-14	92152-0402	D-8
92022-1373	E-10	92027-1651	D-7	92049-0027	D-10	92066-1534	D-3	92144-1266	E-5	92152-0403	D-10
92022-1380	E-11	92027-1817	D-4	92049-0030	C-3	92067-024	C-4	92144-1591	B-11	92152-0404	D-10
92022-1475	C-8	92027-1847	E-12	92049-0040	C-4	92069-1007	F-7	92144-1761	C-9	92152-0405	E-4
92022-1601	E-9	92027-1847	F-4	92049-0041	C-4	92069-1080	F-4	92145-0397	B-14	92152-0406	E-10
92022-161	B-3	92027-1885	C-11	92049-0094	B-14	92070-0020	C-11	92145-0401	E-13	92152-0407	E-10
92022-170	D-8	92028-1507	D-5	92049-1062	B-8	92070-0021	C-11	92145-0417	E-4	92152-0431	D-8
92022-1827	B-14	92033-0019	C-8	92049-1223	D-9	92071-0040	E-12	92145-0453	B-14	92152-0437	E-3
92022-1868	B-11	92033-0046	D-9	92049-1225	E-6	92072-031	F-6	92145-0457	B-14	92152-0445	D-7
92022-2220	B-6	92033-1037	B-12	92049-1328	D-10	92072-056	D-5	92145-0458	B-11	92152-0524	B-12
92022-239	E-4	92033-1172	B-12	92049-1475	C-3	92072-1085	D-5	92145-0514	E-10	92152-0585	D-5
92022-304	C-13	92033-1188	B-5	92049-1542	C-4	92072-1239	E-12	92145-0541	B-9	92152-0591	E-13
92022-304	C-3	92033-1262	D-9	92049-1573	E-4	92072-1239	F-6	92145-1260	E-8	92152-0609	E-3
92022-3041	F-5	92033-3731	C-12	92049-1612	E-3	92072-3872	E-14	92145-1354	E-8	92152-1139	D-10
92022-3043	D-3	92037-147	C-14	92049-1613	E-3	92072-3872	F-6	92145-1414	B-13	92152-1255	B-6
92022-3043	D-4	92037-1827	F-6	92049-7501	D-4	92075-1787	E-12	92145-1493	B-14	92152-1340	E-4
92022-3714	D-7	92039-0039	D-12	92051-005	C-3	92075-1806	E-12	92150-1014	B-6	92152-1346	E-12
92022-3743	D-3	92039-3763	F-9	92055-0016	C-7	92075-1901	C-14	92150-1014	D-13	92152-1414	B-14
92022-3744	D-5	92042-007	B-3	92055-0046	B-3	92075-1912	D-5	92150-1156	B-7	92152-1419	B-14
92025-1870	B-8	92043-0004	E-9	92055-0110	C-4	92075-277	D-5	92150-1433	C-11	92152-1455	D-9
92025-1871	B-8	92043-0130	C-3	92055-0128	B-12	92081-1502	E-10	92150-1451	E-7	92152-1462	E-3
92025-1872	B-8	92043-0130	C-4	92055-0135	E-10	92092-1058	E-6	92150-1452	E-7	92152-7501	D-4
92025-1873	B-8	92043-0140	B-14	92055-0136	C-12	92093-0033	E-6	92150-1650	B-9	92153-0338	B-3
92025-1874	B-8	92043-1356	E-8	92055-074	C-8	92093-0062	D-8	92150-1694	C-14	92153-0339	B-3
92025-1875	B-8	92043-1506	C-3	92055-091	B-13	92093-0104	B-6	92150-1711	D-5	92153-0429	D-10
92025-1876	B-8	92043-1654	B-13	92055-091	C-4	92093-0116	B-6	92150-1719	E-6	92153-0530	B-13
92025-1877	B-8	92043-1676	B-14	92055-1141	C-4	92093-1435	D-8	92150-1771	E-8	92153-0627	E-7
92025-1878	B-8	92043-4009	B-3	92055-1146	C-4	92093-1436	D-10	92150-1811	E-10	92153-0627	E-9
92025-1879	B-8	92043-4009	B-5	92055-1276	C-12	92104-0004	F-8	92150-1858	E-4	92153-0695	B-3
92025-1880	B-8	92045-0024	C-3	92055-1351	E-10	92104-1063	F-8	92150-1919	E-10	92153-0695	C-4
92025-1881	B-8	92045-0031	C-3	92055-1352	B-4	92104-1064	F-8	92150-1934	B-3	92153-0695	C-9
92025-1882	B-8	92045-0035	C-3	92055-1370	C-12	92107-005	F-8	92151-1134	C-4	92153-0717	B-9
92025-1883	B-8	92045-0037	C-3	92055-1577	C-9	92107-1053	F-8	92151-1199	C-4	92153-0773	E-11
92025-1884	B-8	92045-0038	C-3	92055-1622	C-5	92110-0002	F-8	92151-1336	C-4	92153-0801	D-11
92025-1885	B-8	92045-0039	C-4	92055-520	E-4	92110-0017	F-8	92151-1392	E-3	92153-0807	E-11
92025-1886	B-8	92045-0056	C-3	92057-0078	B-9	92110-1152	F-8	92151-1392	E-4	92153-0810	B-3
92025-1887	B-8	92045-0057	C-3	92057-0119	E-4	92110-1153	F-8	92151-1516	B-3	92153-0844	B-5
92025-1888	B-8	92045-0069	E-4	92058-1060	E-4	92111-1051	F-8	92151-1537	E-11	92153-0848	B-14
92025-1889	B-8	92045-0112	E-3	92062-1078	C-3	92122-0020	D-5	92151-1546	C-13	92153-0848	C-3
92025-1890	B-8	92045-0113	E-3	92065-097	C-3	92122-0021	C-8	92151-1647	F-7	92153-0892	D-5
92025-1982	B-8	92045-1432	C-3	92066-0002	B-3	92122-1201	B-12	92151-1793	E-8	92153-0892	F-3
92025-1983	B-8	92046-0023	B-12	92066-0024	B-3	92122-1216	E-4	92151-1930	B-14	92153-0925	D-5
92025-1984	B-8	92046-0027	D-8	92066-0032	D-4	92139-0084	E-6	92151-1930	B-9	92153-0937	E-6
92025-1985	B-8	92046-1010	C-3	92066-0068	B-3	92139-0152	B-12	92151-1930	C-13	92153-0995	D-5
92026-0064	C-4	92046-1046	D-9	92066-0074	D-8	92139-0153	B-12	92151-1930	C-4	92153-1101	F-3
92026-1217	B-14	92046-1144	D-10	92066-0075	C-4	92139-0154	B-12	92152-0237	D-12	92153-1283	C-6
92027-1168	F-3	92046-1148	C-3	92066-0077	D-8	92139-0155	B-12	92152-0237	D-5	92153-1380	B-9
92027-1313	F-5	92046-1151	D-10	92066-0082-AG	D-3	92139-0213	E-6	92152-0250	D-11	92153-1486	D-8



This catalog covers:

**'08 KSF450B8F**

GRID NO.

**B-16**

This grid covers:

**Part Name Index**

Air Cleaner.....	B-6
Battery Case.....	D-7
Brake Pedal.....	E-5
Cables.....	E-14
Camshaft(s).....	B-9
Chassis Electrical Equipment.....	F-6
Clutch.....	B-11
Crankcase.....	C-3
Crankshaft.....	B-10
Cylinder.....	B-5
Cylinder Head.....	B-3
Cylinder Head Cover.....	B-4
Decals(Green).....	F-11
Decals(White)(EU).....	F-10
Engine Cover(s).....	C-4
Footrests.....	D-11
Frame.....	D-3
Frame Fittings.....	D-5/D-6
Front Brake.....	E-8
Front Fender(s).....	D-12
Front Hub.....	E-3
Front Master Cylinder.....	E-7
Front Suspension.....	D-9
Fuel Injection.....	C-7
Fuel Pump.....	C-6
Fuel Tank.....	E-12
Gear Change Drum.....	B-13
Gear Change Mechanism.....	B-14
Generator.....	C-10
Guard(s).....	F-3

Handlebar.....	E-11
Headlight(s).....	F-4
Ignition Switch.....	F-7
Ignition System.....	C-11
Labels.....	F-9
Manual(EU).....	F-12
Muffler(s).....	B-7
Oil Filter.....	C-9
Oil Pump.....	C-8
Owner's Tools.....	F-8
Piston(s).....	B-5
Radiator.....	C-14
Rear Brake.....	E-10
Rear Fender(s).....	D-13
Rear Hub.....	E-4
Rear Master Cylinder.....	E-9
Rear Suspension.....	D-10
Seat.....	E-13
Shift Fork(s).....	B-13
Shock Absorber(s).....	E-6
Starter Motor.....	C-12
Steering Shaft.....	D-4
Swingarm.....	D-8
Taillight(s).....	F-5
Tensioner.....	B-9
Throttle.....	C-5
Tires.....	D-14
Transmission.....	B-12
Valve(s).....	B-8
Water Pump.....	C-13

This catalog covers:

**'08 KSF450B8F**

GRID NO.

**C-16**

This grid covers:

**Part Name Index**

Air Cleaner.....	B-6
Battery Case.....	D-7
Brake Pedal.....	E-5
Cables.....	E-14
Camshaft(s).....	B-9
Chassis Electrical Equipment.....	F-6
Clutch.....	B-11
Crankcase.....	C-3
Crankshaft.....	B-10
Cylinder.....	B-5
Cylinder Head.....	B-3
Cylinder Head Cover.....	B-4
Decals(Green).....	F-11
Decals(White)(EU).....	F-10
Engine Cover(s).....	C-4
Footrests.....	D-11
Frame.....	D-3
Frame Fittings.....	D-5/D-6
Front Brake.....	E-8
Front Fender(s).....	D-12
Front Hub.....	E-3
Front Master Cylinder.....	E-7
Front Suspension.....	D-9
Fuel Injection.....	C-7
Fuel Pump.....	C-6
Fuel Tank.....	E-12
Gear Change Drum.....	B-13
Gear Change Mechanism.....	B-14
Generator.....	C-10
Guard(s).....	F-3

Handlebar.....	E-11
Headlight(s).....	F-4
Ignition Switch.....	F-7
Ignition System.....	C-11
Labels.....	F-9
Manual(EU).....	F-12
Muffler(s).....	B-7
Oil Filter.....	C-9
Oil Pump.....	C-8
Owner's Tools.....	F-8
Piston(s).....	B-5
Radiator.....	C-14
Rear Brake.....	E-10
Rear Fender(s).....	D-13
Rear Hub.....	E-4
Rear Master Cylinder.....	E-9
Rear Suspension.....	D-10
Seat.....	E-13
Shift Fork(s).....	B-13
Shock Absorber(s).....	E-6
Starter Motor.....	C-12
Steering Shaft.....	D-4
Swingarm.....	D-8
Taillight(s).....	F-5
Tensioner.....	B-9
Throttle.....	C-5
Tires.....	D-14
Transmission.....	B-12
Valve(s).....	B-8
Water Pump.....	C-13

This catalog covers:

'08 KSF450B8F

GRID NO.

**D-16**

This grid covers:

**Part Name Index**

Air Cleaner.....	B-6
Battery Case.....	D-7
Brake Pedal.....	E-5
Cables.....	E-14
Camshaft(s).....	B-9
Chassis Electrical Equipment.....	F-6
Clutch.....	B-11
Crankcase.....	C-3
Crankshaft.....	B-10
Cylinder.....	B-5
Cylinder Head.....	B-3
Cylinder Head Cover.....	B-4
Decals(Green).....	F-11
Decals(White)(EU).....	F-10
Engine Cover(s).....	C-4
Footrests.....	D-11
Frame.....	D-3
Frame Fittings.....	D-5/D-6
Front Brake.....	E-8
Front Fender(s).....	D-12
Front Hub.....	E-3
Front Master Cylinder.....	E-7
Front Suspension.....	D-9
Fuel Injection.....	C-7
Fuel Pump.....	C-6
Fuel Tank.....	E-12
Gear Change Drum.....	B-13
Gear Change Mechanism.....	B-14
Generator.....	C-10
Guard(s).....	F-3

Handlebar.....	E-11
Headlight(s).....	F-4
Ignition Switch.....	F-7
Ignition System.....	C-11
Labels.....	F-9
Manual(EU).....	F-12
Muffler(s).....	B-7
Oil Filter.....	C-9
Oil Pump.....	C-8
Owner's Tools.....	F-8
Piston(s).....	B-5
Radiator.....	C-14
Rear Brake.....	E-10
Rear Fender(s).....	D-13
Rear Hub.....	E-4
Rear Master Cylinder.....	E-9
Rear Suspension.....	D-10
Seat.....	E-13
Shift Fork(s).....	B-13
Shock Absorber(s).....	E-6
Starter Motor.....	C-12
Steering Shaft.....	D-4
Swingarm.....	D-8
Taillight(s).....	F-5
Tensioner.....	B-9
Throttle.....	C-5
Tires.....	D-14
Transmission.....	B-12
Valve(s).....	B-8
Water Pump.....	C-13

This catalog covers:

**'08 KSF450B8F**

GRID NO.

**E-16**

This grid covers:

**Part Name Index**

Air Cleaner.....	B-6
Battery Case.....	D-7
Brake Pedal.....	E-5
Cables.....	E-14
Camshaft(s).....	B-9
Chassis Electrical Equipment.....	F-6
Clutch.....	B-11
Crankcase.....	C-3
Crankshaft.....	B-10
Cylinder.....	B-5
Cylinder Head.....	B-3
Cylinder Head Cover.....	B-4
Decals(Green).....	F-11
Decals(White)(EU).....	F-10
Engine Cover(s).....	C-4
Footrests.....	D-11
Frame.....	D-3
Frame Fittings.....	D-5/D-6
Front Brake.....	E-8
Front Fender(s).....	D-12
Front Hub.....	E-3
Front Master Cylinder.....	E-7
Front Suspension.....	D-9
Fuel Injection.....	C-7
Fuel Pump.....	C-6
Fuel Tank.....	E-12
Gear Change Drum.....	B-13
Gear Change Mechanism.....	B-14
Generator.....	C-10
Guard(s).....	F-3

Handlebar.....	E-11
Headlight(s).....	F-4
Ignition Switch.....	F-7
Ignition System.....	C-11
Labels.....	F-9
Manual(EU).....	F-12
Muffler(s).....	B-7
Oil Filter.....	C-9
Oil Pump.....	C-8
Owner's Tools.....	F-8
Piston(s).....	B-5
Radiator.....	C-14
Rear Brake.....	E-10
Rear Fender(s).....	D-13
Rear Hub.....	E-4
Rear Master Cylinder.....	E-9
Rear Suspension.....	D-10
Seat.....	E-13
Shift Fork(s).....	B-13
Shock Absorber(s).....	E-6
Starter Motor.....	C-12
Steering Shaft.....	D-4
Swingarm.....	D-8
Taillight(s).....	F-5
Tensioner.....	B-9
Throttle.....	C-5
Tires.....	D-14
Transmission.....	B-12
Valve(s).....	B-8
Water Pump.....	C-13

This catalog covers:

**'08 KSF450B8F**

GRID NO.

**F-16**

This grid covers:

**Part Name Index**

Air Cleaner.....	B-6
Battery Case.....	D-7
Brake Pedal.....	E-5
Cables.....	E-14
Camshaft(s).....	B-9
Chassis Electrical Equipment.....	F-6
Clutch.....	B-11
Crankcase.....	C-3
Crankshaft.....	B-10
Cylinder.....	B-5
Cylinder Head.....	B-3
Cylinder Head Cover.....	B-4
Decals(Green).....	F-11
Decals(White)(EU).....	F-10
Engine Cover(s).....	C-4
Footrests.....	D-11
Frame.....	D-3
Frame Fittings.....	D-5/D-6
Front Brake.....	E-8
Front Fender(s).....	D-12
Front Hub.....	E-3
Front Master Cylinder.....	E-7
Front Suspension.....	D-9
Fuel Injection.....	C-7
Fuel Pump.....	C-6
Fuel Tank.....	E-12
Gear Change Drum.....	B-13
Gear Change Mechanism.....	B-14
Generator.....	C-10
Guard(s).....	F-3

Handlebar.....	E-11
Headlight(s).....	F-4
Ignition Switch.....	F-7
Ignition System.....	C-11
Labels.....	F-9
Manual(EU).....	F-12
Muffler(s).....	B-7
Oil Filter.....	C-9
Oil Pump.....	C-8
Owner's Tools.....	F-8
Piston(s).....	B-5
Radiator.....	C-14
Rear Brake.....	E-10
Rear Fender(s).....	D-13
Rear Hub.....	E-4
Rear Master Cylinder.....	E-9
Rear Suspension.....	D-10
Seat.....	E-13
Shift Fork(s).....	B-13
Shock Absorber(s).....	E-6
Starter Motor.....	C-12
Steering Shaft.....	D-4
Swingarm.....	D-8
Taillight(s).....	F-5
Tensioner.....	B-9
Throttle.....	C-5
Tires.....	D-14
Transmission.....	B-12
Valve(s).....	B-8
Water Pump.....	C-13